

CCGS15/30

Instruction Manual

BEFORE USING THE POWER SUPPLY UNIT

- Be sure to read this instruction manual thoroughly before using this product. Pay attention to all cautions and warnings before using this product. Incorrect usage could lead to an electrical shock, damage to the unit or a fire hazard.
 - Product individual notes are shown in the instruction manual.
- If there is any difference with common notes individual notes shall have priority.

DANGER

Never use this product in locations where flammable gas or ignitable substances are present.

INSTALLATION WARNING

There is a risk of electric shock, fire or damage, if you do not follow the instructions below.

- When installing this product, ensure that work is done in accordance with the instruction manual.
Installation shall be done by Service personnel with necessary and appropriate technical training and experience.
- Do not cover the product with cloth, paper and etc. Do not place anything flammable object around the product.
- Do not operate and store these products in environments where condensation occurs due to moisture and humidity.

WARNING ON USE

There is a risk of electric shock, fire, burn or damage, if you do not follow the instructions below.

- Do not touch this product or its internal components while product is in operation, or shortly after shutdown.
- Prepare for the unexpected, keep your face and hands away from the product while it is in operation.
- Do not make unauthorized change to this product or remove the cover.
We will not be held responsible if the product was modified, changed or disassembled.
- Do not use this product under unusual conditions such as emission of smoke or abnormal smell and sound etc.
Please stop using it immediately and shut off the product. In such cases, please contact us.
- Do not attempt any repair by yourself, as it is dangerous for the user.
This product will be repaired by our company or an authorized agent designated by our company.
- Please do not use products that have been dropped or subjected to impact.
- Please use within specifications standards for input voltage, output current, output power, ambient temperature, humidity, etc.
- This product was made for general purpose electronic equipment use and is not designed for applications requiring High safety (such as extremely high reliability and safety requirements. Even though high reliability and safety are not required, this product should not be used directly for applications that have serious risk for life and physical safety.
Take sufficient consideration in fail-safe design (such as providing protective circuit or protective device inside the system, providing redundant circuit to ensure no instability when single device failure occurs).
- It is important that this product must not be used in hazardous environments or facilities such as nuclear power control system or life support equipment without our written consent.
- Connect together \perp (Functional earthing) terminal of the product and the ground terminal of the equipment for safety and noise reduction.

CAUTION ON MOUNTING

- Ensure connections to input/output terminals are correct as indicated in the instruction manual before switching on.
- Please use the wires as short and thick as possible.
- Do not use this product in special environment with strong electromagnetic field, corrosive gas (hydrogen sulfide, sulfur dioxide, etc.) or conductive substances and direct sunlight, or places where product is exposed to water or rain.
- Mount this product properly in accordance with the instruction manual, mounting direction and shall properly be ventilated.
- Please shut down the input when connecting input and output of the product.
- When installing in environment where conductive foreign, dust and liquid may be present, please take care to avoid penetration of these foreign material in the power supply by installing filter, to prevent trouble or malfunction.

⚠ CAUTION ON USE

- If the built-in fuse is blown, do not use the product even after replacing the fuse, as there is risk of abnormality inside. Be sure to request repair to our company.
- Please note that the built-in fuse may not operate depending on the input wiring and input line conditions.
- Provide countermeasure for prevention of lightning surge voltage as there is risk of damage due to abnormal voltage.
- Parts with lifetime specifications (built-in electrolytic capacitor) are required to be replaced periodically. Set the overhaul period depending on the environment of usage and request a component replacement to our company. Also, note that there are cases when EOL products cannot change component.
- Take care not to apply abnormal voltage to the output. It might cause failure, smoke or fire.
- Please connect a DC voltage that is insulated with reinforced or double insulation from the primary power source to the input terminals.

⚠ OTHER NOTES OF CAUTION

- If your fingers come into direct contact with the metal edges, there is a risk of injury. When handling, please take sufficient care, such as wearing protective gloves, and work carefully.
- When disposing product, follow disposal laws of each municipality.
- Published EMI (CE, RE) or immunity is the result of measuring the power supply unit under our standard measurement conditions and might not satisfy specification when mounted and wired inside end-user equipment. Use the product after sufficiently evaluating at actual end-user equipment.
- When exporting our products, apply for necessary permissions as required by rules and regulations of Foreign Exchange and Foreign Trade Control Act.
- Take note that traces of sheet metal processing be left in our power supplies. Also, partial discoloration or oxidation may be observed on the sheet metal surface of the product depending on storage conditions, such as in warehouses, but this does not affect the characteristics or reliability of the product.
- Catalogue or contents of the instruction manual may be changed without a prior notice. Refer to latest catalogue or instruction manual.
- Reproduction or reprinting the instruction manual or its portion is forbidden without our permission unless with TDK-Lambda authorization.

⚠ STORAGE METHOD AND STORAGE PERIOD BEFORE IMPLEMENTATION

- Please keep the product in carton box.
- Please do not apply excessive vibration, shock or mechanical stress to the product.
- Please keep away from direct sunlight.
- For storage temperature and humidity, the following conditions shall be used as a guideline :
 - Temperature range : 5~30°C
 - Humidity range : 40~60%RHAvoid places where its temperature and humidity can change drastically. It might cause product degradation or condensation on the product.
- There is tendency that the leakage current of an aluminum electrolytic capacitor may increase when not use for a long time. This phenomenon can be improved by applying voltage to the aluminum electrolytic capacitor to reduce the leakage current through the self-recovery effect of the electrolyte. As a guide if the products have been stored for longer than one year, it is recommended to turn on the product for at least 30 min at no load condition.
 - < Criterion of warm up voltage condition >
 - (1)Implementation period : 1 year or above after the delivery
 - (2)Electrical condition
 - Input voltage : Nominal
 - Load : 0A
 - Ambient temperature : Normal temperature
 - Time : 30 minutes or more

3. Terminal Explanation (Top view)

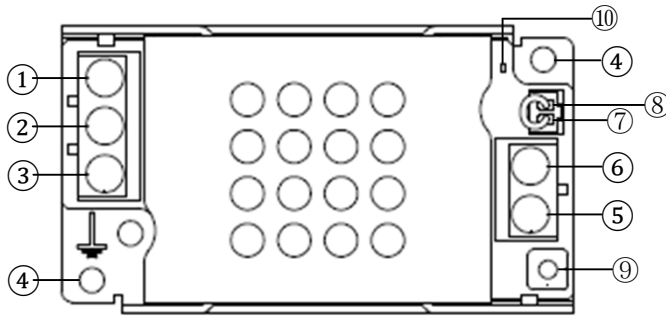

CCGS-S Standard

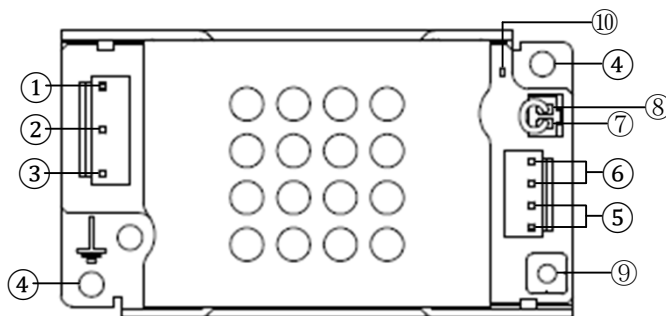

CCGS-S/B

CCGS-S

- ① -Vin : -Input Terminal
- ② +Vin : +Input Terminal
- ③ \perp : Earth Terminal
- ④ Mounting hole (hole diameter : ϕ 4.5mm)
 This hole is electrically connected to terminal of ③.
 Please mount using M4 screws.
- ⑤ +Vout : +Output Terminal
- ⑥ -Vout : -Output Terminal
- ⑦ SG : -Remote ON/OFF Control Terminal
- ⑧ RC : +Remote ON/OFF Control Terminal
- ⑨ V_{ADJ} : Output Voltage Adjustment Trimmer
 (Output Voltage increases by turning the VR Clockwise direction.)
- ⑩ Output indication LED
 (Green LED lights when output ON)

*All screws size is M3.5

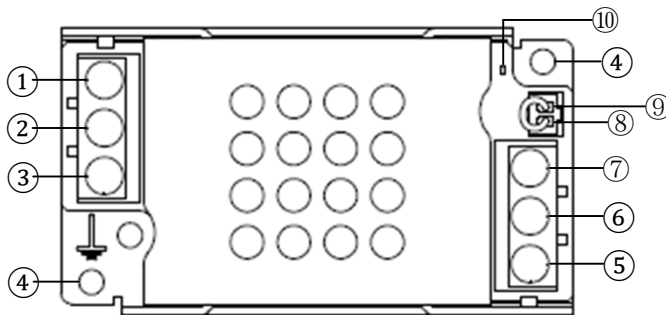

CCGS-D Standard

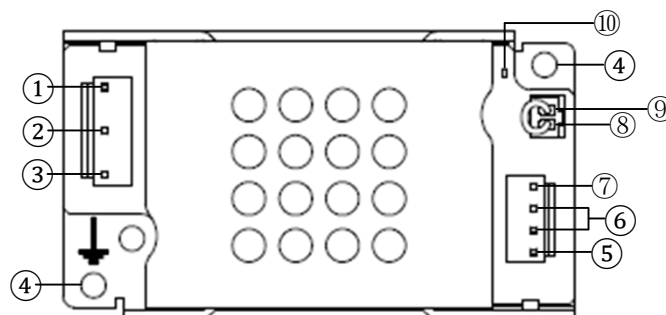

CCGS-D/B

CCGS-D

- ① -Vin : -Input Terminal
- ② +Vin : +Input Terminal
- ③ \perp : Earth Terminal
- ④ Mounting hole (hole diameter : ϕ 4.5mm)
 This hole is electrically connected to terminal of ③.
 Please mount using M4 screws.
- ⑤ +Vout : +Output Terminal
- ⑥ COM : Common Ground Terminal
- ⑦ -Vout : -Output Terminal
- ⑧ SG : -Remote ON/OFF Control Terminal
- ⑨ RC : +Remote ON/OFF Control Terminal
- ⑩ Output indication LED
 (Green LED lights when output ON)

*All screws size is M3.5

4. Sequence Time Chart

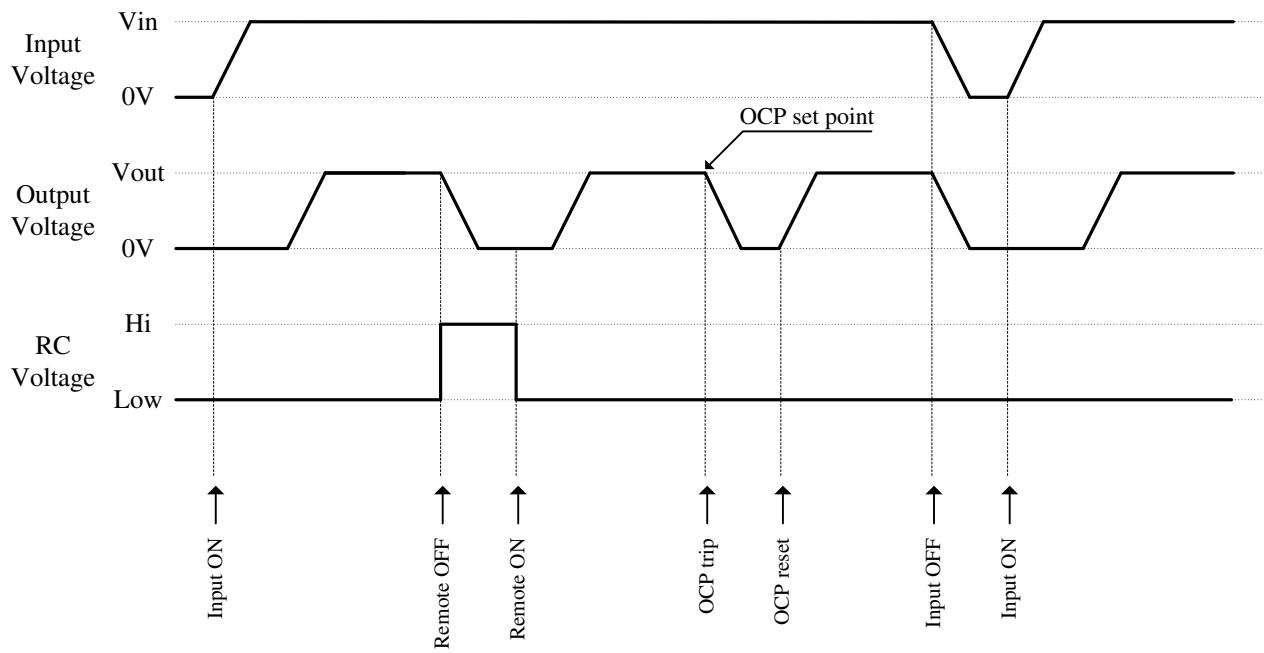

5. Terminal Connecting Method

Pay attention to the input wiring. If applying wrong connection, the power supply will be damaged. Also, if the output reactivates when the input is cut off, use thicker and shorter wiring.

- Input must be off when making connections.
- When applying Protection Ground, use the terminal with the symbol '⏏' or use fixing screw to the (sheet-metal) chassis.
- The output load line and input line shall be separated to improve noise sensitivity.
- If you will not be using the remote ON/OFF function, connect using the included short piece that is already installed in CN2 at the time of shipment.

If you will be using the remote ON/OFF function, remove the short piece. Also, be sure to use twisted or shielded wire for the remote ON/OFF signal line, and wire it separately from the output wire.

- Make sure that the current flowing through the terminals is within the product's rated value.
- Do not apply stress to PCB, when connecting or removing connector.
- Use input/output connector (housing) specified by the table below.
- Use recommended crimping tool. Connector is not included with this product. (Refer to the following)

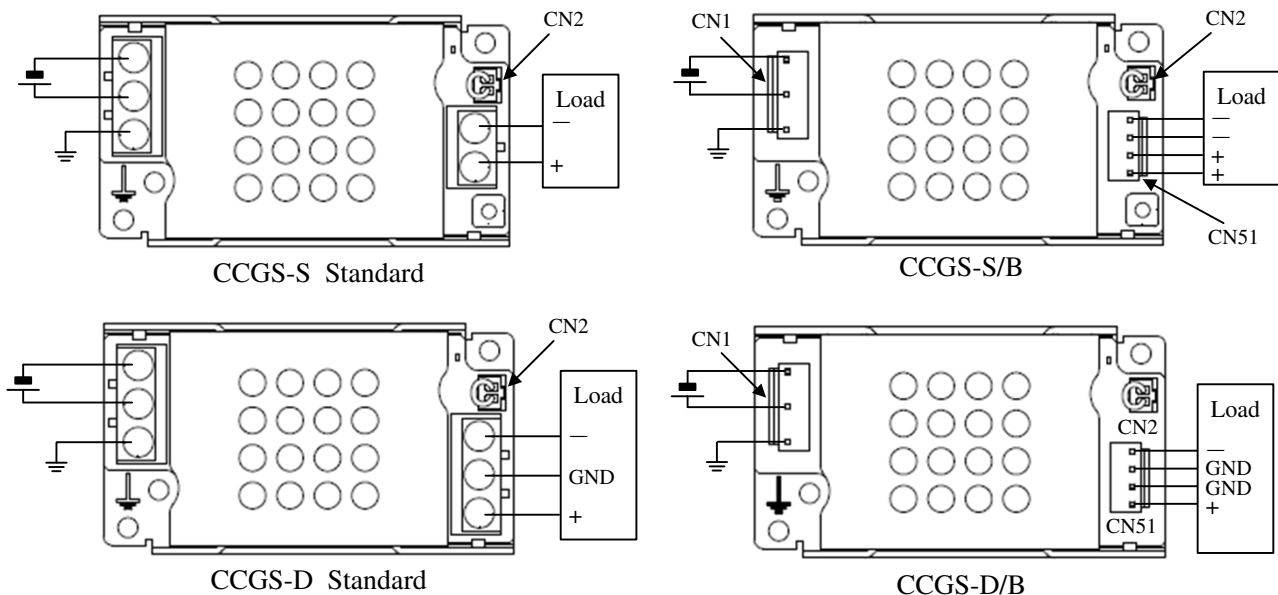

*Recommended torque : M3.5 screw 1.0N·m

Connector / Housing and terminal Pin

Terminal	Symbol	Connector	Housing	Terminal Pin	Manufacturer
Input connector	CN1	B3P5-VH	VHR-5N (AWG#22 ~ AWG#18)	SVH-21T-P1.1 BVH-21T-P1.1	JST
Output connector	CN51	B4P-VH	VHR-4N (AWG#22 ~ AWG#18)		
Remote ON/OFF connector	CN2	B2B-XH	XHP-2 (AWG#28 ~ AWG#22)	SXH-001T-P0.6 BXH-001T-P0.6	

Matching housing and terminal : Not included with the product.

Crimping Tool

Terminal Pin	Crimping Tool	Manufacturer
SVH-21T-P1.1 BVH-21T-P1.1	AP-K2N, YC-160R	JST
SXH-001T-P0.6 BXH-001T-P0.6	AP-K2N, YC-110R	

6. Explanation of Functions and Precautions

6-1. Input Voltage Range

Input voltage range for CCGS series is indicated below.

Input Voltage Range

CCGS_{xx}-24-xxx : 9 - 36VDC

CCGS_{xx}-48-xxx : 18 - 76VDC

Take note that power supply might be damaged or not meet specification when applied input voltage which is out of specified range.

Ripple voltage(V_{rpl}) which results from rectification and filtering of commercial AC line is might be included within the input voltage as shown below.

In this case, ripple voltage must be limited within the voltage described below.

Allowable Input Ripple Voltage : 2Vp-p

When input ripple voltage exceed above value, the output ripple voltage might be large.

Take note that sudden input voltage change might be cause variation of output voltage transitionally.

Moreover, maximum value and minimum value of input voltage waveform must not go beyond the limit of above input voltage range.

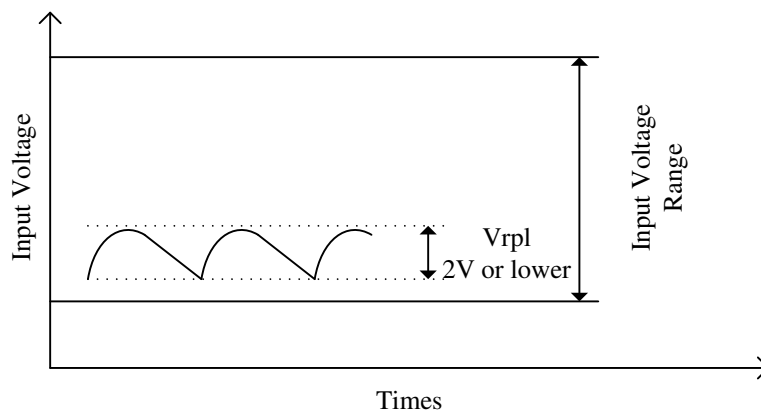

6-2. Output Voltage Adjustment Range (Only CCGS-S)

When shipped from the factory, the output voltage is set to the rated value.

The output voltage can be adjusted by turning the output voltage adjustment volume (V_{ADJ}).

Turning the volume clockwise increases the output voltage.

The output voltage should be set to $\pm 10\%$ of the rated output voltage.

When increasing the output voltage, reduce the output current accordingly so as not to exceed the maximum output power.

In case of adjusting output voltage lower, maximum output current is until rated maximum output current of specification.

6-3. Maximum Output Ripple and Noise

The standard specification for maximum ripple value is measured according to below measurement circuit. When load lines are longer, ripple will become larger. In this case, electrolytic capacitor, film capacitor, etc. might be necessary to use across the load terminal. The output ripple cannot be measured accurately if the probe ground lead of oscilloscope is too long.

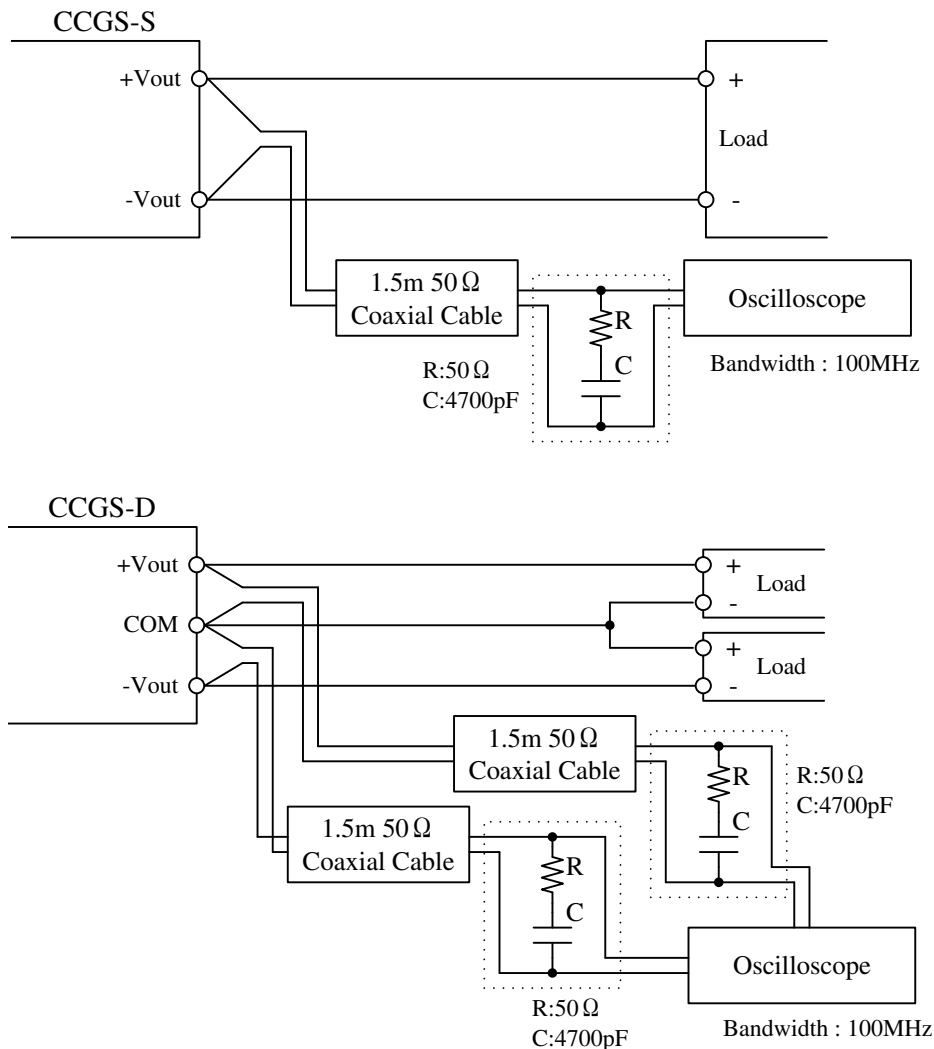

6-4. Line Regulation

Maximum value of output voltage change when input voltage is gradually varied (steady state) within specified input voltage range.

When using at dynamic input mode, output voltage fluctuation might increase.

When using CCGS30-24-xxS, output voltage might become unstable at input voltage dips or short interruption. Please check the actual characteristics before use.

6-5. Load Regulation

Load regulation of specification is the variation value of output voltage when output current is gradually varied (steady state) within specified output current range.

When using at dynamic load mode, output voltage fluctuation might increase.

Also, when CCGS-D is used with unbalanced load, the output voltage with the higher load factor decreases and the output voltage with the lower load factor increases.

A thorough pre-evaluation must be performed before using this power supply.

6-6. Over Current Protection (OCP)

When short circuit or output current is in overload condition, it becomes intermittent operation. Output will recover when short circuit or overload conditions are released. Take note that power supply might be damaged at continuous overload conditions depending on thermal conditions. OCP setting value is fixed and therefore, can not be externally adjusted.

6-7. Remote ON/OFF Control (RC, SG terminal)

The output can be enabled/disabled by RC terminal without turning the input supply on and off. Please note that the RC and SG terminal (CN2) are input side circuits.

Condition between RC and SG terminal	Output Status
Short or $0V \leq V_{RC} \leq 0.5V$	ON
Open or $4V \leq V_{RC} \leq 18V$	OFF

6-8. Series Operation

For series operation, either method (A) or (B) is possible.

Method (A) Series Operation for High Output Voltage

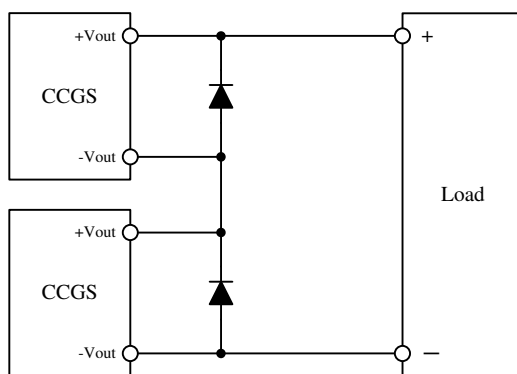

Method (B) ±Output Series Operation

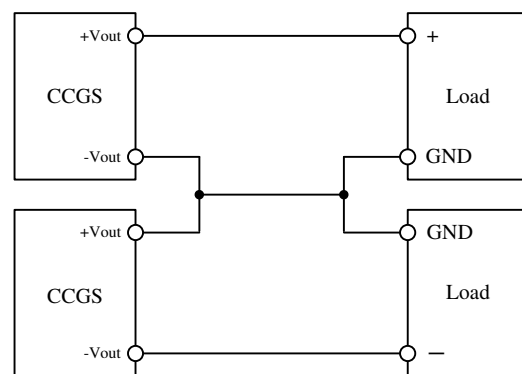

When using the series operation method (A), please connect bypass diodes. Please select a bypass diode with maximum forward current rating more than output load current. And maximum reverses voltage must withstand each power supply output voltage.

<Reference>

CCGS-D can be used as 24V or 30V single output by connecting +Vout and -Vout to the load.

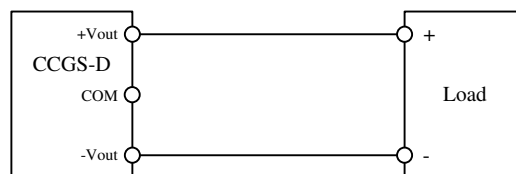

6-9. Parallel Operation

Parallel operation cannot be used.

6-10. Redundant Operation

Redundant operation is possible for loads that are within the maximum output power of one power supply. When one power supply is shut-down by the power failure etc., another one can continue to provide power.

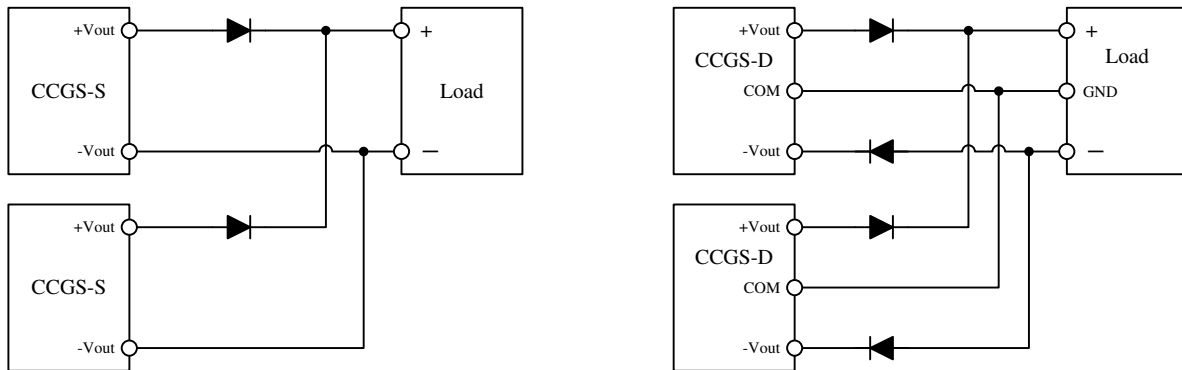

6-11. Isolation Test

Isolation resistance between Output - \perp terminal is more than 100M Ω at 500VDC.

For safety operation, voltage setting of DC isolation tester must be done before the test. Ensure that the unit is fully discharged after the test.

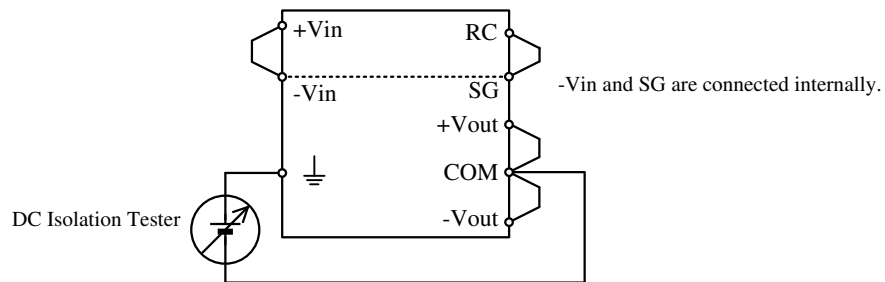

6-12. Withstand Voltage

This series is designed to withstand 1.5kVDC between Input and Output, 1.5kVDC between Input and \perp and 1.0kVDC between Output and \perp each for 1 minute. When testing withstand voltage, set current limit of the withstand voltage test equipment to 10mA.

The applied voltage must be gradually increased from zero to the testing value and then gradually decreased for shut down. When timer is used, the power supply may be damaged by high impulse voltage at timer switch on and off. Connect input and output as follows.

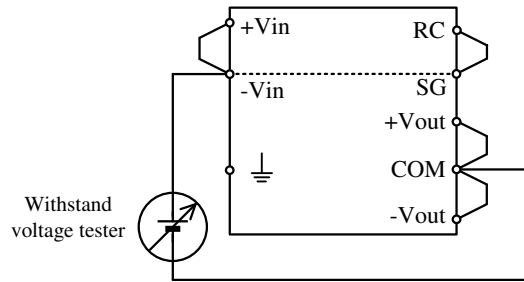

(A) Input - Output

-Vin and SG are connected internally.

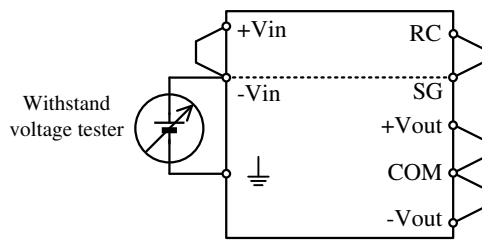

(B) Input - \perp

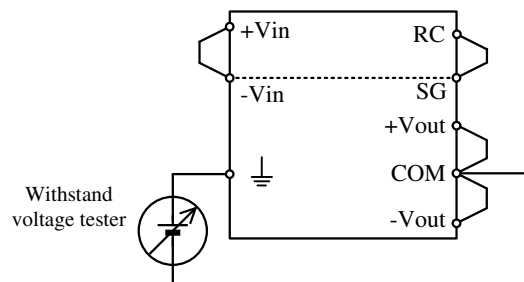

(C) Output - \perp

7. Mounting Method

7-1. Mounting Direction

Recommended standard mounting method is (A). Method (B)-(E) are also possible.
 Do not mount Method (F).

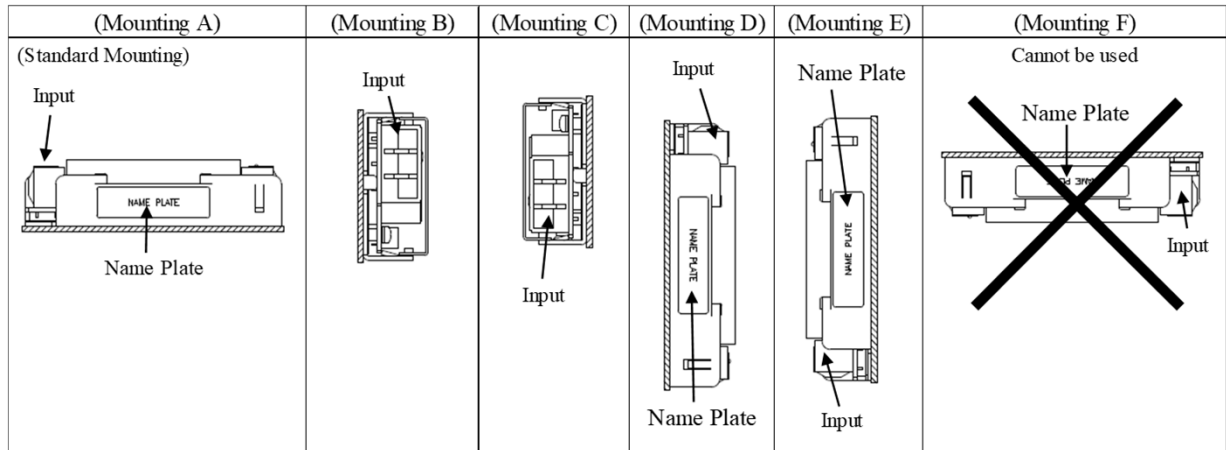

7-2. Output Derating

The output derating for (A)-(E) is the same. Please use within the output derating range below.
 The output derating value is based on 100% of the rated output power value with natural convection cooling.

CCGS15-S

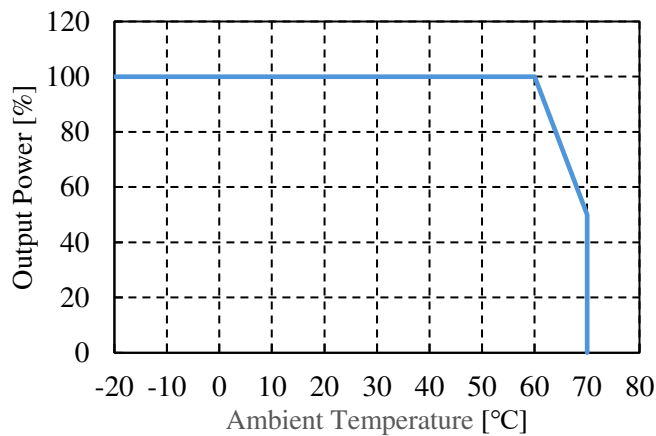

Ambient Temperature (°C)	Output Power (%)
-20 ~ +60	100
+70	50

CCGS15-D

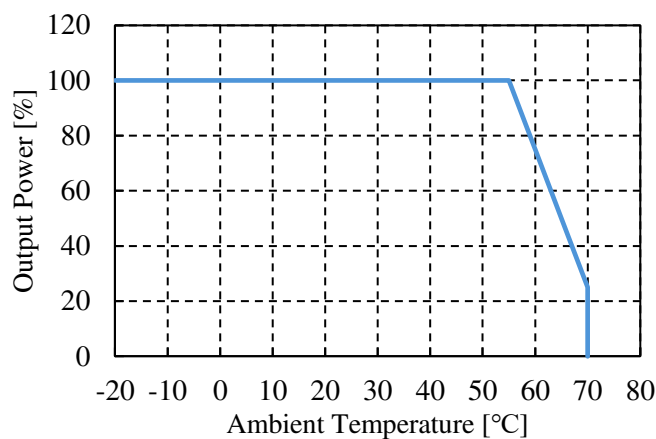

Ambient Temperature (°C)	Output Power (%)
-20 ~ +55	100
+70	25

CCGS30-24-05S

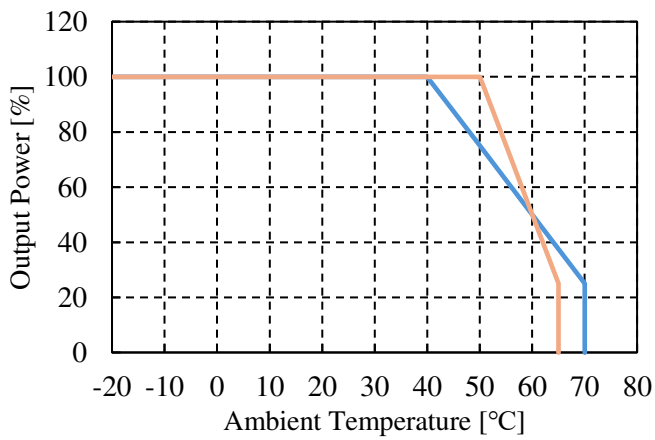

— 10V < Vin ≤ 18V

Ambient Temperature (°C)	Output Power (%)
-20 ~ +40	100
+70	25

— 18V < Vin ≤ 36V

Ambient Temperature (°C)	Output Power (%)
-20 ~ +50	100
+65	25

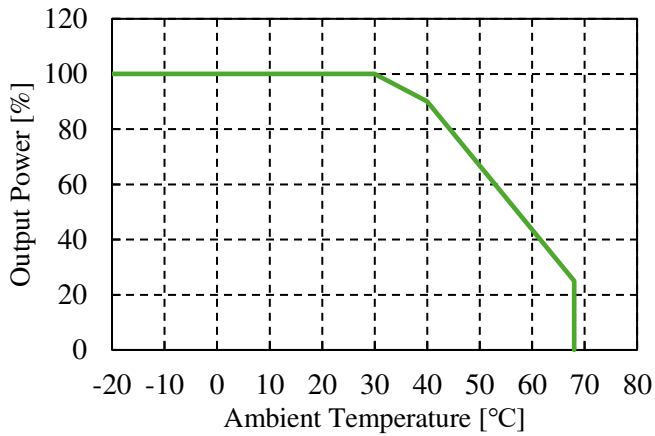

— 9V ≤ Vin ≤ 10V

Ambient Temperature (°C)	Output Power (%)
-20 ~ +30	100
+40	90
+68	25

CCGS30-24-03S, 12S, 15S

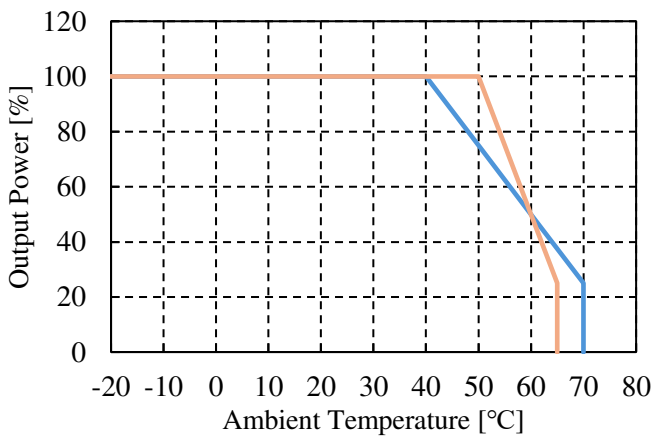

— 9V ≤ Vin ≤ 18V

Ambient Temperature (°C)	Output Power (%)
-20 ~ +40	100
+70	25

— 18V < Vin ≤ 36V

Ambient Temperature (°C)	Output Power (%)
-20 ~ +50	100
+65	25

CCGS30-48-xxS

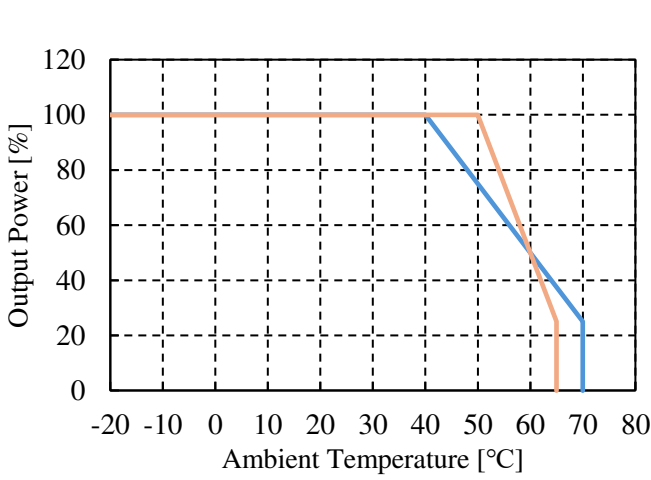

— 18V ≤ Vin ≤ 36V

Ambient Temperature (°C)	Output Power (%)
-20 ~ +40	100
+70	25

— 36V < Vin ≤ 76V

Ambient Temperature (°C)	Output Power (%)
-20 ~ +50	100
+65	25

CCGS30-24-xxD

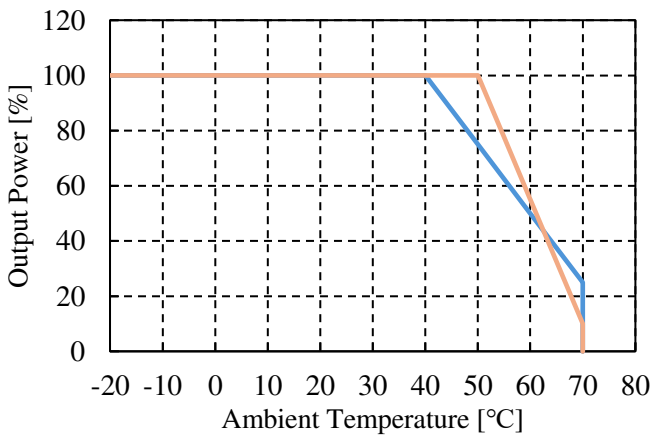

— 9V ≤ Vin ≤ 18V

Ambient Temperature (°C)	Output Power (%)
-20 ~ +40	100
+70	25

— 18V < Vin ≤ 36V

Ambient Temperature (°C)	Output Power (%)
-20 ~ +50	100
+70	10

CCGS30-48-xxD

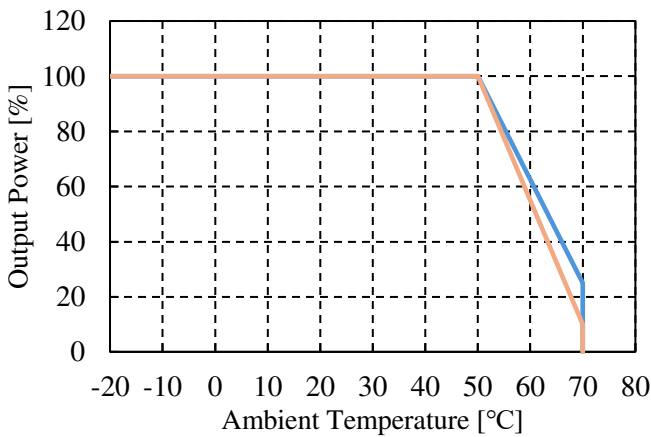

— 18V ≤ Vin ≤ 36V

Ambient Temperature (°C)	Output Power (%)
-20 ~ +50	100
+70	25

— 36V < Vin ≤ 76V

Ambient Temperature (°C)	Output Power (%)
-20 ~ +50	100
+70	10

7-3. Precaution for Mounting

- (1) Connect Protective Earth Terminal (\perp) to the Ground of the application equipment.
- (2) The holes on the bottom (A) and side (B) of the CCGS chassis (opposite the nameplate) are for mounting. Use M4 screws to mount.
 The maximum allowable screw insertion length into the side (B) is 6mm. When mounting, take into consideration the thickness of the chassis on the equipment and any incomplete threads.
- (3) Recommended fastening torque for mounting M4 screw : 1.27N•m

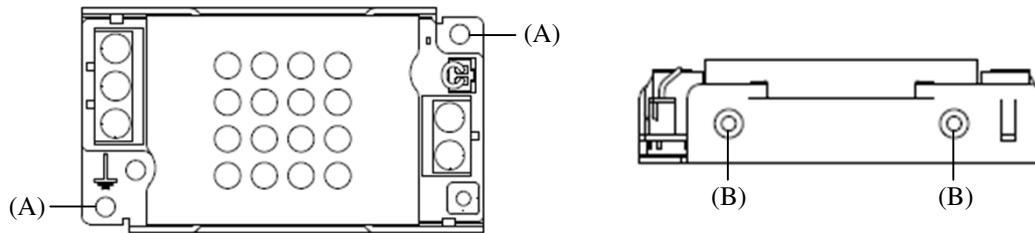

8. Wiring Method

This power supply is primarily designed and manufactured to be used and enclosed in other equipment. The installation, wiring, grounding and end application of the power supply in the equipment system may influence its EMC characteristics. Therefore, the EMC performance has to be tested on end system level. Additional filtering may be required depends on application and installation methods. Please refer to the following.

- (1) The output load line and input line shall be separated each other and twisted individually to improve noise.
- (2) Use all lines as thick and short as possible to made lower impedance.
- (3) Noise can be reduced by attaching a capacitor to the input and output terminals.
- (4) For safety and EMI considerations, connect between \perp terminal and Frame Ground terminal of equipment firmly.
- (5) Please refer to the table below for recommended wire, torque, and crimp terminals.

Recommended Wire	Recommended Torque	Recommended crimp-type terminal		
		D (MAX)	t (MAX)	Mounting piece (MAX)
AWG16-24	M3.5 Screws 1.0N•m	6.8mm	1.0mm	1 piece
			0.8mm	2 pieces

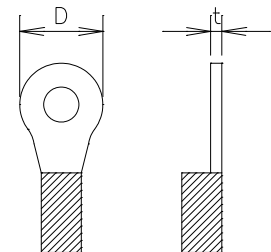

- Note 1 : When using separate loads, use of two pcs. of 0.8mm thick crimp-type terminal is recommended.
 Note 2 : For recommended diameter, refer to wire maker recommended allowable current and voltage drop.
 Note 3 : Use crimp-type terminal for connection to terminal.

9. The life expectancy

The life of the power supply depends on the life of the built-in aluminum electrolytic capacitor. The life is described in reliability data. The life of the aluminum electrolytic capacitor varies depending on the load current, and the ambient temperature.

Please refer to "Electrolytic Capacitor Lifetime".

Please do not use the product which passed over the life expectancy.

There is a risk of unexpected output shutdown and specifications may not be satisfied.

If the product which passed over the life expectancy, please consider replacing it with a new one.

10. External Fuse Rating

Refer to the following fuse rating when selecting the external input fuse.

The CCGS series has built-in the fuse with the same current ratings as shown below.

CCGS15-24-xxS, CCGS15-24-xxD : 6.3A
 CCGS15-48-xxS, CCGS15-48-xxD : 5A
 CCGS30-24-xxS, CCGS30-24-xxD : 10A
 CCGS30-48-xxS, CCGS30-48-xxD : 6.3A

11. External Output Capacitor

For case of abrupt changes in load current or the line to the load is long, operation might become unstable. In this case, it is possible to stabilize the output voltage by attaching capacitor.

CCGS-S : between +Vout and -Vout terminal

CCGS-D : between +Vout and COM terminal, -Vout and COM terminal

Maximum capacitance of external output capacitor is shown below.

Output Model	Maximum capacitance
3.3V	10,000uF
5V	7,200uF
12V, ±12V	1,200uF
15V, ±15V	1,000uF

Note) When using 3.3V and 5V output models of CCGS30-S, output voltage might become unstable at input voltage dips or short interruption on connection output capacitor. Please check the actual characteristics before use.

12. Before concluding that the unit is at fault

- (1) Check if the rated input voltage is connected.
- (2) Check if the wiring of input and output is correct.
- (3) Check if the terminal screw is fastened with specified torque certainly.
- (4) Check if the wire size is not too thin.
- (5) Check if the output current and output power does not over specifications.
- (6) Check if the output voltage control (V_{ADJ}) is properly adjusted.
- (7) Check if remote ON/OFF (RC/SG) terminal is opened or not. Output turns off if the terminal is opened.
- (8) The power supply may generate noise depending on the magnitude (size) of load fluctuations, frequency, and speed of change.

13. Warranty Period

Warranty period is 5 years.

For damages occurring at normal operation within this warranty period, exchange is free of charge.

Please read the General Safety Instruction before using the products.

14. CE MARKING / UKCA MARKING

CE MARKING

CE Marking, when applied to a product or packing material for a product covered by this handbook, CCGS_{xx}-24-_{xx}S/D indicates compliance with EMC Directive and RoHS Directive, CCGS_{xx}-48-_{xx}S/D indicates compliance with Low Voltage Directive, EMC Directive and RoHS Directive.

UKCA MARKING

UKCA Marking, when applied to a product or packing material for a product covered by this handbook, indicates compliance with the Electrical Equipment (Safety) Regulations and Restriction of the Use of Certain Hazardous Substances in Electrical & Electronic Equipment Regulations.

※The safety standard certified input voltage range is 18 - 36VDC.