

# EMC Design for High-Speed Digital Circuits

# EMC Design for Power Lines

TDK Corporation Capacitor Business Group  
Masaaki Togashi

## 1 | Noise Behavior on Power Lines

Arithmetic elements such as digital ICs and operational amplifiers, and actuators such as motors have power lines for supplying the power needed for operation. The load on power lines for ICs and motors occasionally becomes unstable due to changes in power consumption. Power lines are the circuits for transmitting constant voltage and direct current voltage, so fluctuations in the power indicate changes in the current of the load and indicate the transient current. Power lines do not have obvious fluctuations in voltage as is the case with digital signals, but a synchronized transient current flows to the control signal. Most noise generated on power lines is due to this transient current.

The transient current that flows on power lines causes voltage fluctuation due to the parasitic inductance (L) on the power line, or due to resistance (R). When the transition speed of the transient current is expressed as  $di/dt$ , voltage equivalent to  $L \times di/dt$  is induced to the power lines, so voltage fluctuation occurs between the power line and GND. When the voltage fluctuation exceeds the noise margin, a problem occurs. In addition, the transient current of the power source can cause emission noise on the loop between the power line and GND, and the harmonic component of the transient current is transferred and radiates on signal lines and cables, which can cause electromagnetic wave interference.

Transient current behavior differs according to the portion of the circuit. Figure 1 shows the power supply configuration, and shows the voltage fluctuation caused by the transient current.

**Figure 1 Transient Current and Voltage Fluctuation on Power Lines**

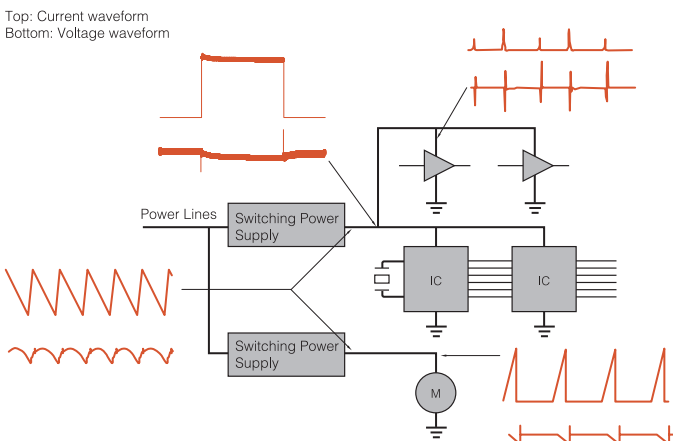

On the gate IC, transient current surges that are synchronized with the clock signal flow to the power supply pins. Figure 2 shows an example of a transient current flowing on a CMOS gate.

**Figure 2 CMOS Gate Power Supply Noise**

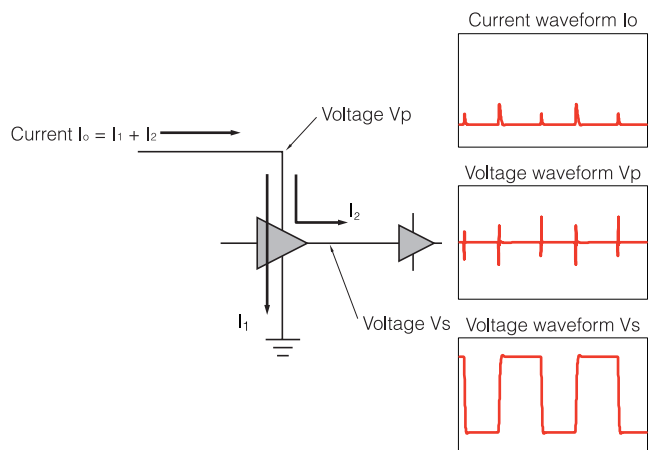

When the clock signal becomes a high-frequency wave, the transient current also becomes a high-frequency wave. Therefore, harmonics increase in the high-frequency band. On an LSI equipped with over 10,000 gates, a large transient current flows temporarily to the power supply terminal at the moment that a program is processed. In addition, when one power line is shared by multiple LSIs and they begin operating at the same time, a larger current flows to the power line, causing voltage drops.

On the other hand, the power line source contains a stable power supply, which generates a predetermined amount of power. Usually, switching power supplies are used. The output from switching power supplies generates a ripple current. The ripple current becomes direct current due to the charge and discharge of the smoothing capacitor, but when the performance of the smoothing capacitor is insufficient, it flows to the power line.

It is important to understand the behavior of transient currents that occur on power lines in order to suppress noise on power lines. Noise countermeasures are implemented through wire design and passive components such as capacitors and coils, while trying as much as possible to localize (seal) the transient current to the load side such as on ICs and actuators.

## 2 | Necessity of IC Bypass Capacitors

### ■ Power Supply Bypass Capacitors

Bypass capacitors must be installed on power supply terminals where transient current flows. Bypass capacitors are also called smoothing capacitors and decoupling capacitors. As shown in Figure 3, bypass capacitors are installed according to the shunt direction to the GND for power lines. Because of this layout, bypass capacitors supply the transient current, which is generated by the operation of the IC, by the electrical charge stored in the capacitor. As a result, the transient current flows through the bypass capacitor and is almost completely stopped from flowing to external power lines. When the bypass capacitor is installed near the power supply pins, the transient current can be localized to a small current loop.

**Figure 3 Power Line Noise Countermeasures**

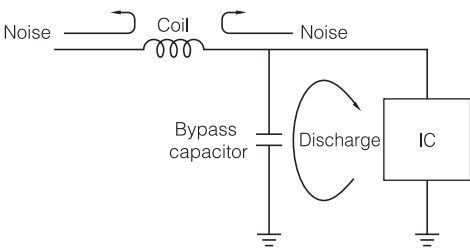

### ■ Bypass Capacitor's Capacitance

Bypass capacitors supply the transient current needed for operating the IC by discharging stored electricity to prevent voltage drops. Therefore, a sufficient electrical charge ( $Q$ ) must be stored to prevent voltage drops after discharge. When the transient current is expressed as  $i(t)$ , and the bypass capacitor supplies the whole transient current ( $i(t)$ ), the electrical charge lost through discharge for the bypass capacitor ( $Q_c$ ) is  $\int i(t) dt$ , so the voltage drop ( $V_c$ ) between the bypass capacitor terminals is expressed according to the following.

$$V_c = (1/C) \int i(t) dt$$

Capacitors need to be selected based on the calculated capacitance ( $C$ ) so that the voltage drop ( $V_c$ ) is within the noise margin.

### ■ Dangers Related to ESR and ESL

ESR (Equivalent Series Resistance) and ESL (Equivalent Series Inductance) are parasitic capacitor components. The bypass capacitor supplies necessary transient current for operating the IC, but sufficient current cannot be supplied when the ESR and ESL are large. This is because the ESR and ESL increase the impedance inside of the bypass capacitor, which interrupts discharging. Figure 4 shows this behavior. Insufficient current flows on external power lines, which causes voltage fluctuation or emission noise by propagating to a peripheral circuit. Capacitors with low ESR and ESL need to be selected for bypass capacitors when the IC operates at a high-frequency range because they have a high  $di/dt$ , and contain high-frequency harmonics.

**Figure 4 Power Supply Bypass Capacitor and Current Waveform**

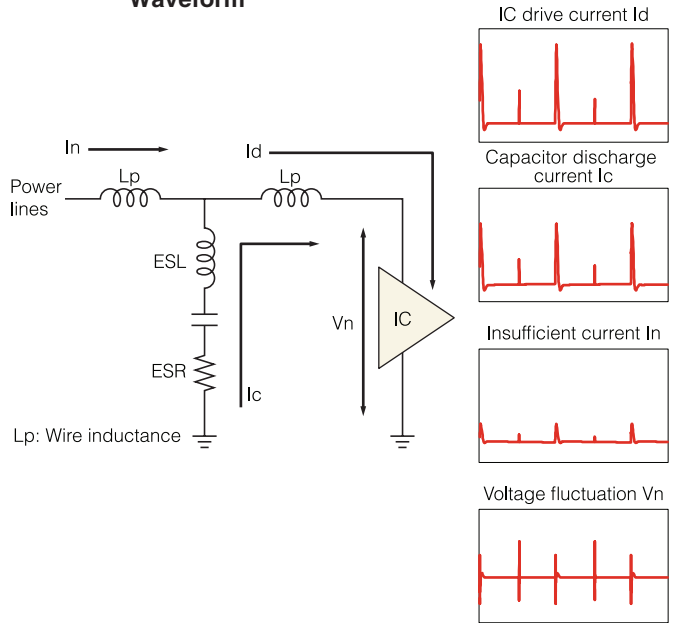

### ■ Multilayer Ceramic Capacitors for Bypass Capacitors

There are various types of capacitors, and generally, tantalum electrolytic capacitors and multilayer ceramic capacitors are used for small type SMD products. Figure 5 shows their respective impedance characteristics. Multilayer ceramic capacitors are effective for bypass capacitors because they have low ESR and ESL, they are compact, and are inexpensive.

**Figure 5 Inductance Characteristics**

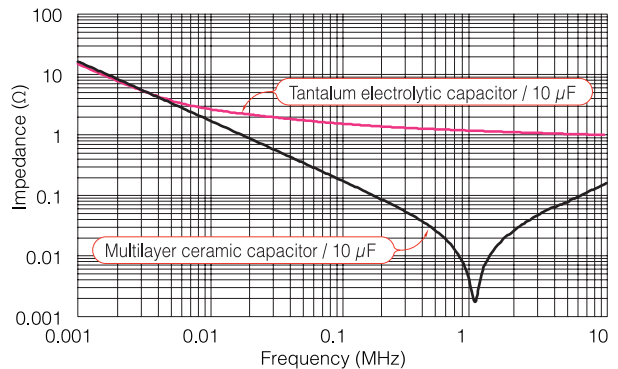

### ■ Bypass Capacitor Layout

Bypass capacitors are usually placed at the inlet of the transient current, which is the source of the noise, where it is closest to the power supply terminal. Figure 6 shows a sample layout. Wires between the power supply terminal and GND pattern, which is the discharge route for the bypass capacitor, should be as short as possible so that the inductance of the wires can be small and the discharged current can be supplied efficiently. This efficiency decreases when the wire inductance is large even if capacitors with low ESR and ESL are used.

**Figure 6 Bypass Capacitor Layout Sample**

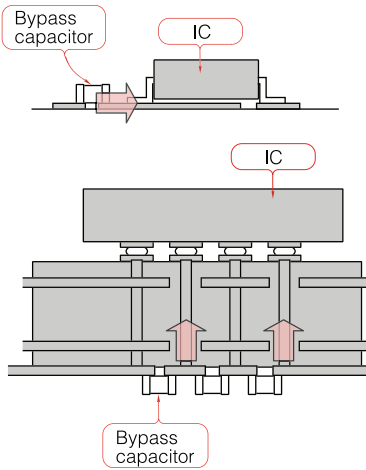

References

[1] Controlling Radiated Emission by Design, Michel Mardiguian / Mitsutoshi Hatori (Editor) / Takehiko Kobayashi (Translator) / Maruzen Co., Ltd.

**Examples of Bypass Capacitor Efficiency**

Figure 7 shows a circuit that is used for evaluating noise suppression efficiency with a tantalum electrolytic capacitor and with a multilayer ceramic capacitor as bypass capacitors.

Figure 8 shows the measurement results. The voltage fluctuation was smaller when the multilayer ceramic capacitor was used as the bypass capacitor than when the tantalum electrolytic capacitor was used. Harmonics were also low over a wider band with the multilayer ceramic capacitor, making it more effective.

**Figure 7 Evaluation Circuit**

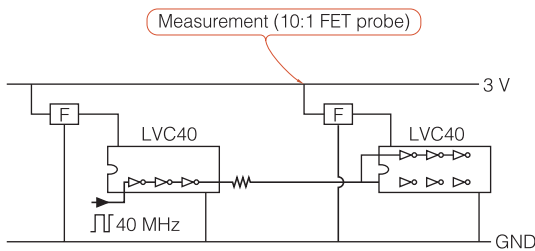

**Figure 8 Measurement Results**

F: Tantalum electrolytic capacitor / 1  $\mu$ F

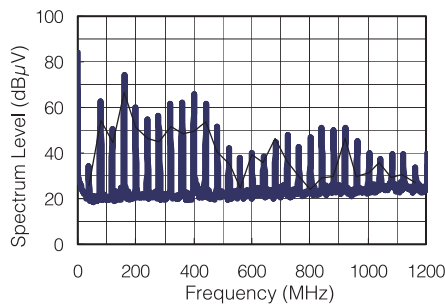
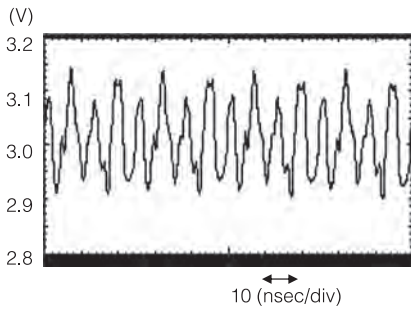

F: Multilayer ceramic capacitor / 0.1  $\mu$ F  
C1608JB1H104K

