

# EMC Countermeasures for In-Vehicle Communication Networks

TDK Corporation Magnetics Business Group  
Toshio Tomonari

## 1 | Introduction

In recent years, Electronic Control Units (ECUs) have become more commonly used according to the higher functionality of vehicles. Because of this, standard interfaces for connections between devices are needed, and optimal interfaces are used according to each usage for connections between devices. Common vehicle communication network interfaces are CAN and LIN, and the next-generation interface

FlexRay that can allow for drive-by-wire systems. These interfaces have different data rates, but the internal connections are the same. Various noise sources exist inside of vehicles, so it is necessary to design circuits by taking EMC into consideration so that devices are not affected by external noise and do not themselves emit noise. This will explain EMC countermeasures for CAN, FlexRay, and LIN in-vehicle communication networks.

Figure 1 Examples of Vehicle Communication Networks (CAN / LIN / MOST / FlexRay)

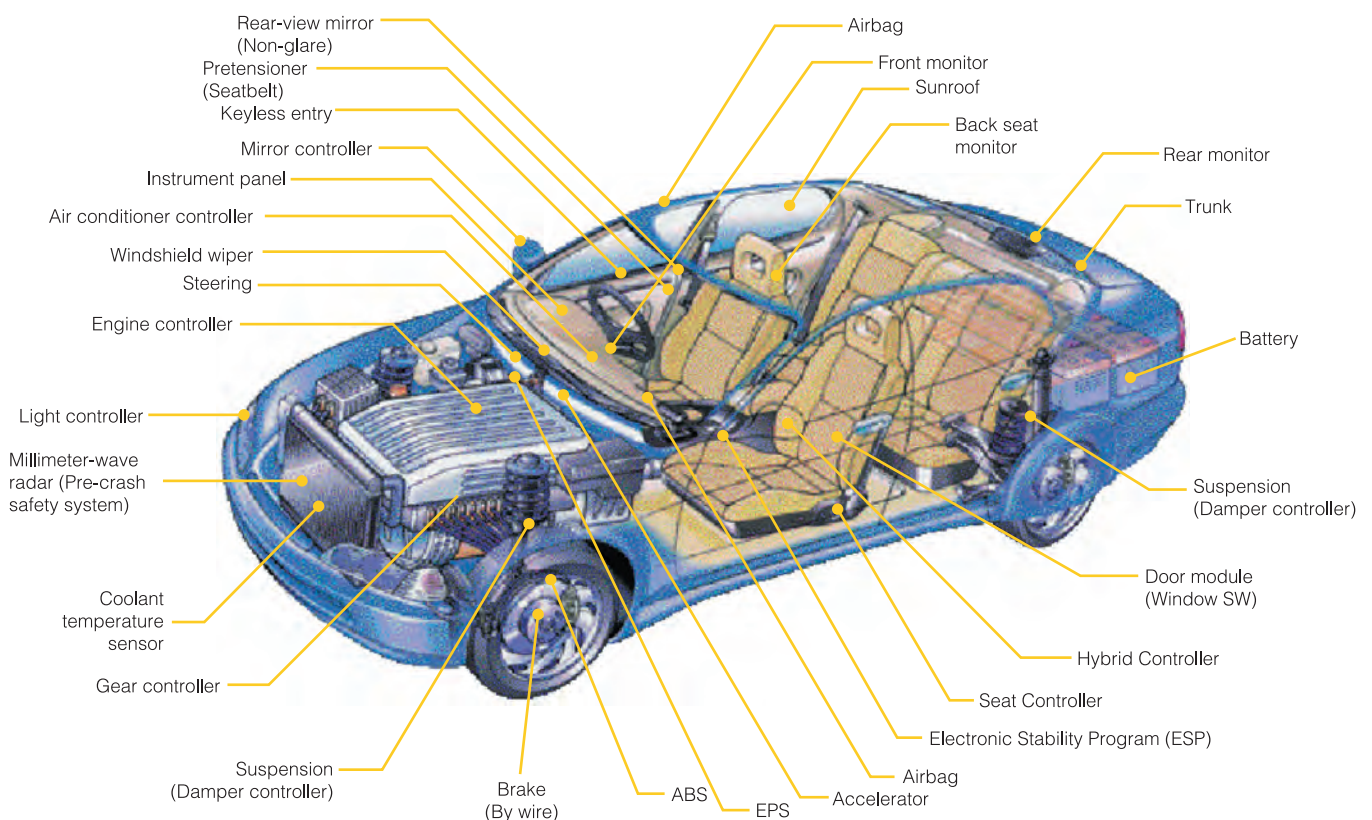

## 2 | Why do Cars Need Communication Networks?

Buzz words in the current automobile industry are 'fuel efficient' and 'low emissions.' The global oil crisis of 2008 is still fresh in people's minds. Since then, US automobile manufacturers have been finally moved to develop low-emission vehicles. The US government also began to take positive steps toward counteracting global warming. The whole world is now moving in that direction. Under this situation, developed countries are establishing stricter standards for vehicle emissions (EURO5 in Europe, ZEV regulations in California USA, and Japan's 2010 Emission Regulations).

While emission regulations have become stricter, advanced collision avoidance controller functions such as parking assists, backup cameras, millimeter-wave radars have become important elements. Figure 1 shows how electronic control units are used for current vehicles. This shows that ECUs are for everything including familiar functions such as door operation and basic vehicle functions such as suspension, driving, turning, and stopping functions.

In the future, vehicle functions will continue to become even more advanced. However, advanced functions will require even more ECUs, which in turn will require more harnesses. As a result, fuel consumption and emissions may increase. Emission regulations and advanced vehicle functions are in conflict with each other. One solution to this problem is vehicle communication networks. Figure 2 shows the merits of vehicle communication networks. Efforts for developing network devices can help reduce the number of harnesses needed for one-to-one connections. In addition, vehicle communication networks can be sorted into three different types according to the purpose (Figure 3).

The CAN and LIN interfaces are used for the body system because they do not require high-speed communication. However, the high-speed and safe FlexRay interface is used for the powertrain system which handles core functions such as driving, turning and stopping. The MOST and IDB1394 interfaces are mainly used for multimedia systems that need to send image and audio data because they are capable of transferring data over 100 Mbps.

**Figure 2 Merits of Vehicle Communication Networks**

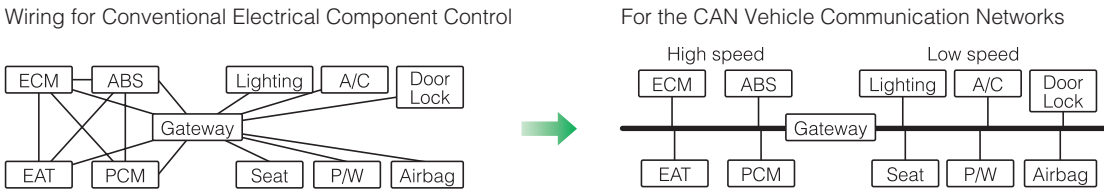

**Figure 3 Vehicle Communication Network Configuration**

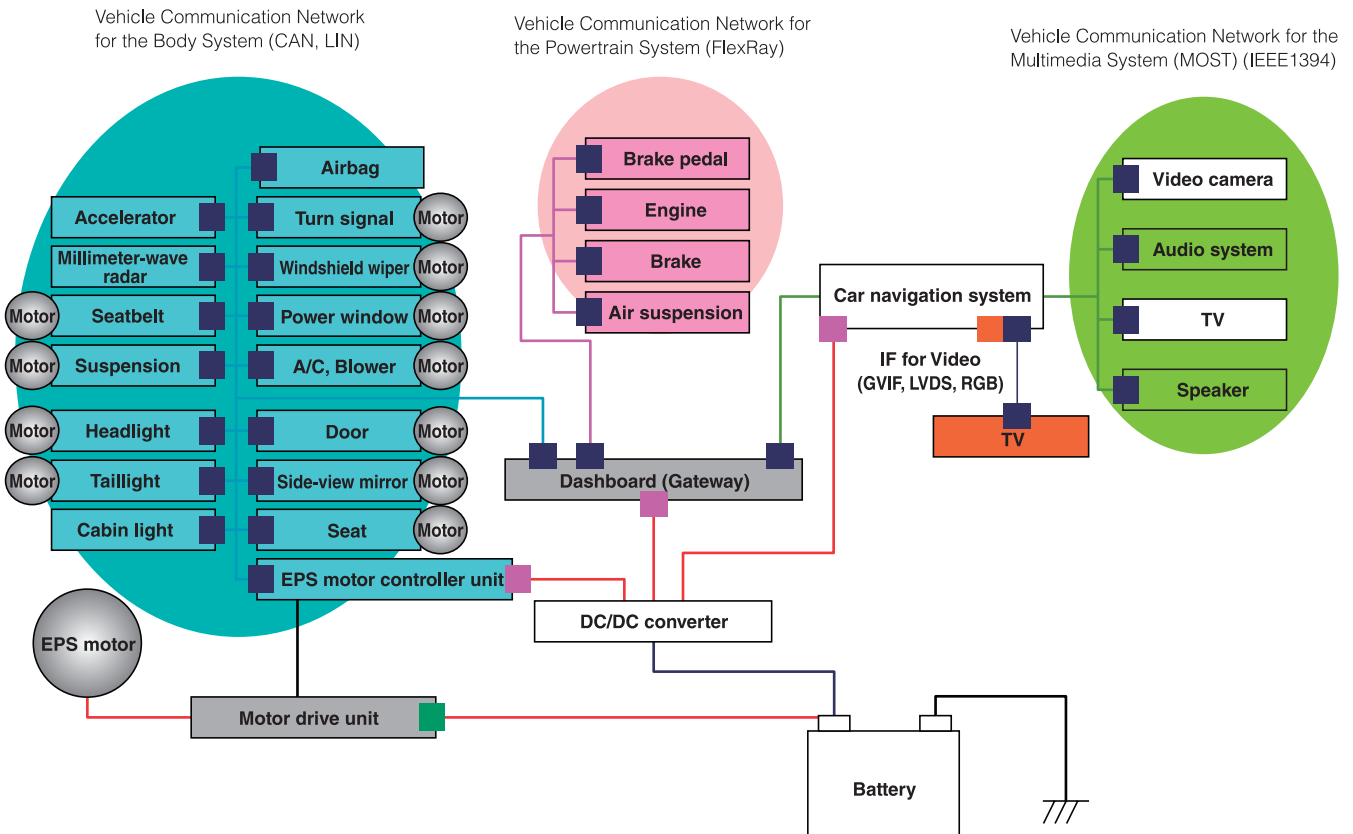

### 3 | Vehicle Noise Standards and Issues Related to EMC

CISPR25 is the international EMC standard for vehicle noise emission, and ISO11451/11452 the international EMC standard for immunity (Figure 4).

**Figure 4 Vehicle EMC Standards**

Evaluation of Actual Vehicle	
Emission Standards	CISPR12, CISPR25 EN55012, 25
Immunity Standards	ISO11451-2 (Radiated Immunity)
	ISO11451-3 8 (Radiated Immunity) <sup>*Vehicle wireless devices</sup>
	ISO11451-4 (BCI Method)
	ISO10605 (ESD)
Component Evaluation	
Emission Standards	CISPR25 EN55025
Immunity Standards	ISO11452-2 (Radiated Immunity)
	ISO11452-3 (TEM Cell Method)
	ISO11452-4 (BCI Method)
	ISO11452-5 (Stripline)
	ISO11452-7 (DPI)
	ISO10605 (ESD)

**Figure 5 Strict EMC Standards for Vehicle Devices**

(a) Radiation noise

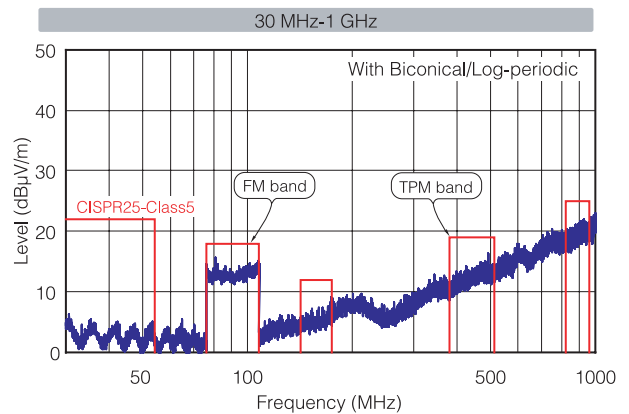
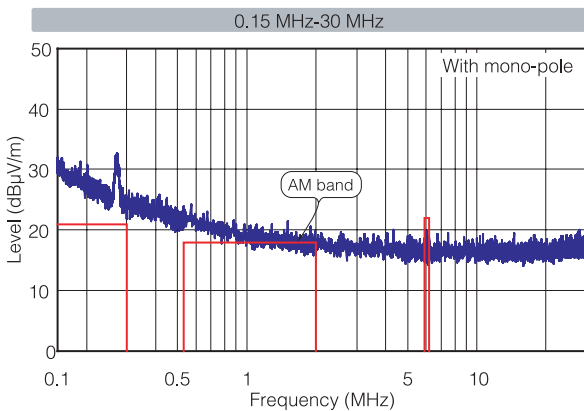

(b) Immunity

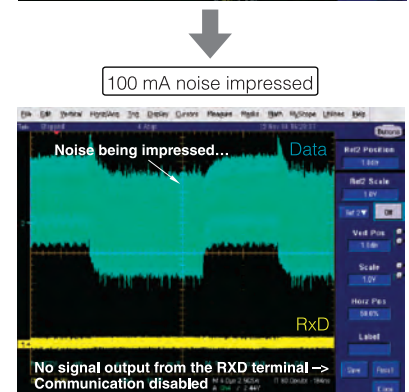
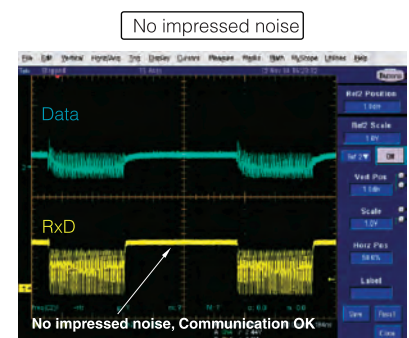
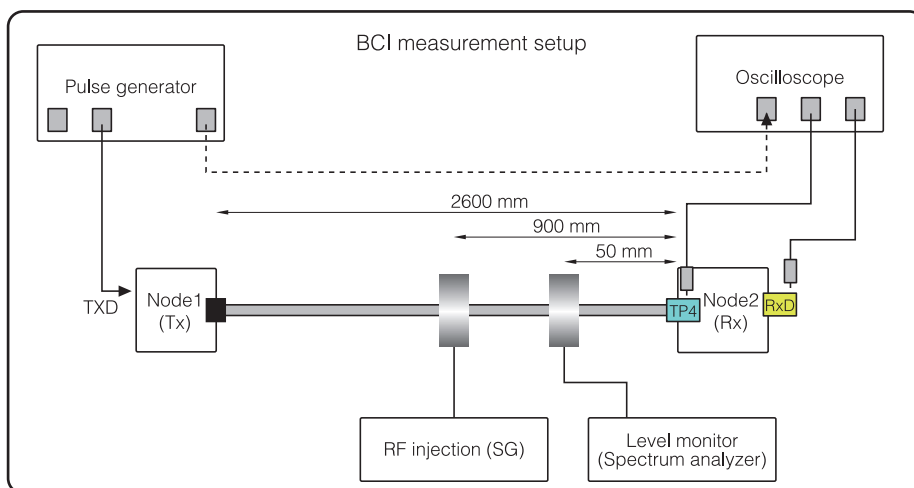

#### Immunity Test Conditions and Results

The BCI (Bulk Current Injection) Method was used for testing.

A large current occurred on the data line when noise was impressed.

Because differential transmission used, there was no effect up to a certain current level, but when the impressed current was over 100 mA, a communication error occurred.

Errors due to noise related to devices equipped in vehicles can directly affect the life of the user. It is also necessary to prevent interference with wireless systems such as AM and FM radio and TPM (Tire Pressure Monitoring) sensors. Therefore, the standards for these regulations are much stricter than with standards for devices such as TVs and computers.

Figure 5 shows examples of this. Figure 5 (a) shows the measurement results for dark current noise in a 3 m anechoic chamber. It was found that it was over the standard in the band range from 150 kHz to 1 MHz even when no electronic device was operating. This was due to the performance of the antenna amplifier. Clearly, it is difficult for the dark current noise level to be within the standard. When this standard is applied without the margin in the 1 MHz or higher band where it does not depend on the performance of the amplifier, the radiation noise level from the ECU was almost not permitted.

Figure 5 (b) shows an example of an immunity measurement result. When noise is applied to the UTP cable that connects the vehicle communication network interface

driver using the BCI method, communication was disabled. When components for improving EMC were removed, noise resistance became worse, which caused communication to be disabled. This demonstrates the importance of EMC design for immunity.

With the exception of LIN and CAN, vehicle communication networks use differential transmission because it has low amplitude, low noise radiation, and is resistant to outside noise. Physical layers are used in consideration of EMC. However, there are various noise locations, noise types, and various frequencies inside of vehicles including noise related to the ferromagnetic field due to high currents, noise related to the motor system, and burst noise from the sparkplug. Therefore, ECUs may be affected even when differential transmission is used.

In addition, from the viewpoint of radiation noise, differential transmission should have low EMI, but in reality, the noise emission level for the whole system is not zero because the two lines (plus and minus lines) are not perfectly symmetrical. Therefore, measures need to be taken to improve noise immunity and emission.

## 4 | Effectiveness of Common Mode Filters

As explained in other chapters, Common Mode Filters are effective at improving EMC for differential transmission (for more details about Common Mode Filters, refer to “Common Mode Filters that Eradicate the Causes of Emission Noise Without Affecting Signals” and “Improving EMC for High-Speed Differential Interfaces”).

The following two benefits can be acquired by using Common Mode Filters.

1. Suppression of radiation noise
2. Improved immunity

This shows that Common Mode Filters can be used to resolve problems related to EMC for vehicle communication networks.

Figure 6 shows the results for Common Mode Filter effectiveness, which were verified using an actual CAN-IC. A general ACT45B-510-2P Common Mode Filter for CAN was used, which will be explained later.

The next section will explain recommended TDK Common Mode Filters for CAN and FlexRay, and countermeasures and filter for improving EMC for LIN.

**Figure 6 Effectiveness of Common Mode Filters for the CANBUS Line (Radiation Noise)**

(a) Radiation Noise Measured Data

Horizontal

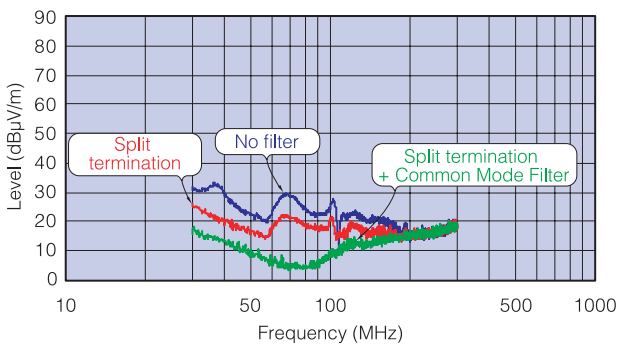

Vertical

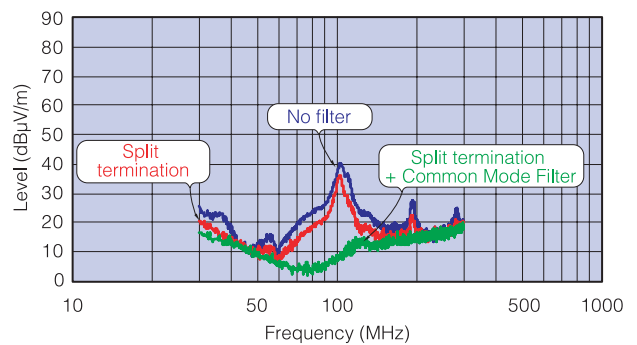

Mono-pole

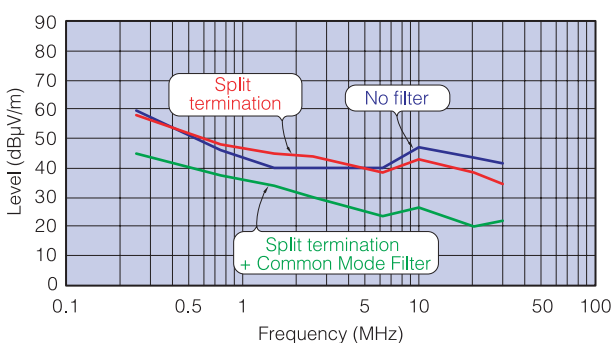

Measurement Setup

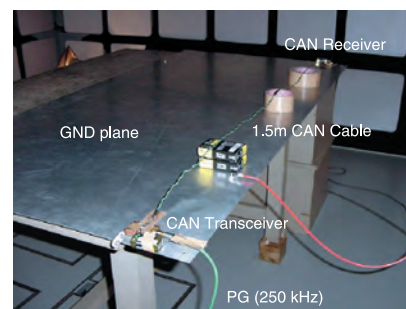

\* Split termination is explained below.

(b) Measured circuit

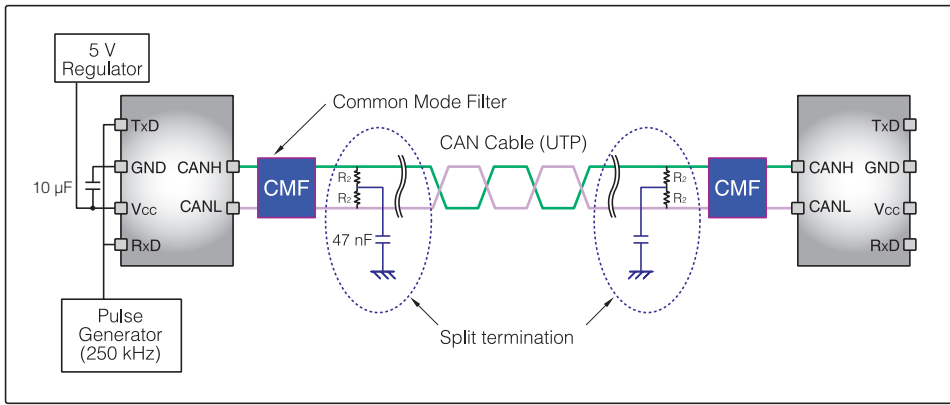

Split termination is for making common mode components flow to the GND by connecting the midpoints of two resistors with the GND so that the common mode components can be reduced.

For CAN and FlexRay, it is applied to the end terminal resistor of the main bus.

When the branch node ends with a resistance of less than 10 kΩ, split termination can apply to this resistance for suppressing common mode noise. However, the effectiveness is limited due to the high resistance.

## 5 | CANBUS Filter

CAN has been around since it was adopted by Daimler AG back in 1992. It was not a standard from the beginning. After each manufacturer developed their own interfaces for vehicle communication networks, CAN was selected as a standard around the year 2000 for development efficiency, cost reduction, and connectivity based on standardization. Since CAN has been used for over ten years, TDK's Common Mode Filters have long been used for CANBUS through several transitions. TDK's Common Mode Filters for CANBUS are sorted into two series based on the configuration (Figure 7).

**Figure 7 TDK's Common Mode Filter Lineup for CANBUS**

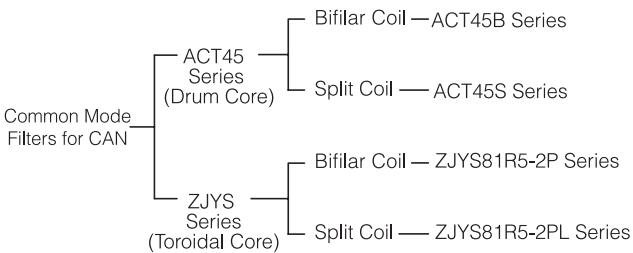

One is the toroidal core type ZJYS Series and the other is the drum core type ACT Series.

These have the following characteristics.

- (1) Split coil type with impedance in the differential mode (Dual mode filter)
- (2) Bifilar coil type with no impedance in the differential mode (Common Mode Filter)

Type (2) Common Mode Filters are normally used because they do not affect signals. Type (1) has impedance in order to suppress differential mode noise components, so they are used according to the type of noise.

The operating temperature range for the ZJYS Series is  $-40$  to  $+125$  °C, and the operating temperature range for the ACT45B Series is  $-40$  to  $+150$  °C\*. These are both designed to meet all requirements as components of vehicle devices.

\* The ACT45B Series is designed so that reliability is guaranteed up to 150 °C for high-temperature environments such as the engine room.

## 6 | Filters for FlexRay

The next generation vehicle communication network "FlexRay" has the same EMC problems as CAN. Circuit design is an important way to improve immunity and suppress radiation noise with FlexRay. The transmission rate is faster than with CAN (maximum transmission rate is 10 Mbps depending on the specifications). Therefore, it is necessary to consider signal quality when selecting a filter. In addition, a high common mode impedance is needed for improving immunity. Based on the above, the FlexRay specifications \*1 and application notes\*2 released by the FlexRay Consortium mention the electrical specification for Common Mode Filters. The following are the published filter specification.

DCR: 2 Ω or less

(Operating Temperature Range:  $-40$  to  $+125$  °C)

L value: 100 μH

Leakage inductance: < 1 μH

Reference standards are according to the following.



\*1 FlexRay\_Electrical\_Physical\_Layer\_Specification\_V2.1\_Rev.B

\*2 FlexRay\_Electrical\_Physical\_Layer\_Application\_Notes\_V2.1\_Rev.B

TDK provides two types of Common Mode Filters for FlexRay; a drum core type and a toroidal core type (Figure 8).

Both products use solderless connection technology.

**Figure 8 Common Mode Filters for FlexRay**

ACT45 Series (Drum Core)		ZJYS90V-101-2P (Toroidal Core)
		
ACT45R-101-2P	Product Name	ZJYS90V-101-2PTL
Solderless Joint	Features	Solderless Joint
100 $\mu$ H	Inductance	100 $\mu$ H
-40 to +150 $^{\circ}$ C	Operating Temperature Range	-40 to +125 $^{\circ}$ C
<2 $\Omega$ [150 $^{\circ}$ C]	DCR	<2 $\Omega$ [125 $^{\circ}$ C]

**Figure 9 Method for Improving EMC for LIN**

(a) Example Circuit for EMC Countermeasures

**LIN (Local Interconnect Network)**

LIN bus uses single-ended transmission, so an LC filter is best

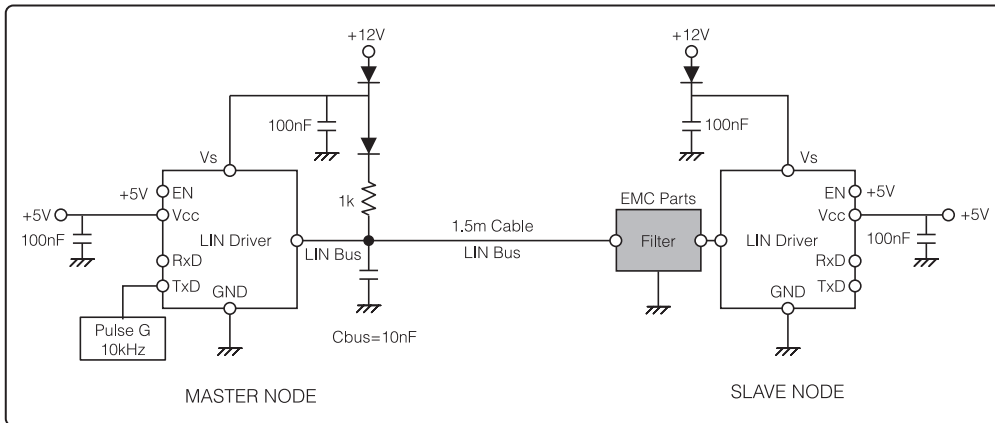

Test Conditions:

- : Filter was installed on the slave node side
- : Diameter: 1 mm, Harness: 1.5 m
- : The harness was also connected to the GND and a 12 V battery harness
- : 20 kbps (= 10 kHz) was impressed to the TxD terminal of the master node
- : Cbus = 10 nF

(b) Evaluation Circuit

**LIN Harness BCI (Bulk Current Injection) Test**

Measured in an Anechoic Chamber: A probe was used to impress a high-frequency current to the cables.

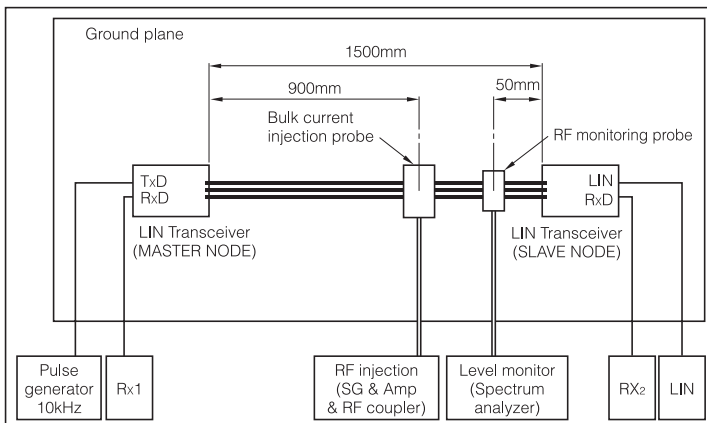

**7 | Noise Countermeasures for LIN**

LIN bus uses single-ended transmission instead of differential transmission. Therefore, ferrite beads, capacitors, and three-terminal filters are effective countermeasures for noise. The LIN transmission rate is slower than CAN and FlexRay at under 100 kbps. It is also necessary to use beads and capacitors with a relatively large invariable. Figure 9 shows examples of countermeasures based on an immunity test.

When no countermeasure components were used during the immunity test, communication errors occurred according to the impressed noise. The influence of the impressed noise could be removed by using a three-terminal filter (TDK Part No.: ACF321825-331, C:300 pF).

Recommended Components for LIN

Three-terminal filter: ACF Series

Inductor: NLV Series

NLV25T-XXXX-EFD

NLV32T-XXXX-EFD

NLCV Series

NLCV25T-XXXX-EFD

NLCV32T-XXXX-EFD



(c) Test Results

**Output waveform measured from the receiving end Rx when BCI (0 to 100 mA) was impressed**

No EMC filter

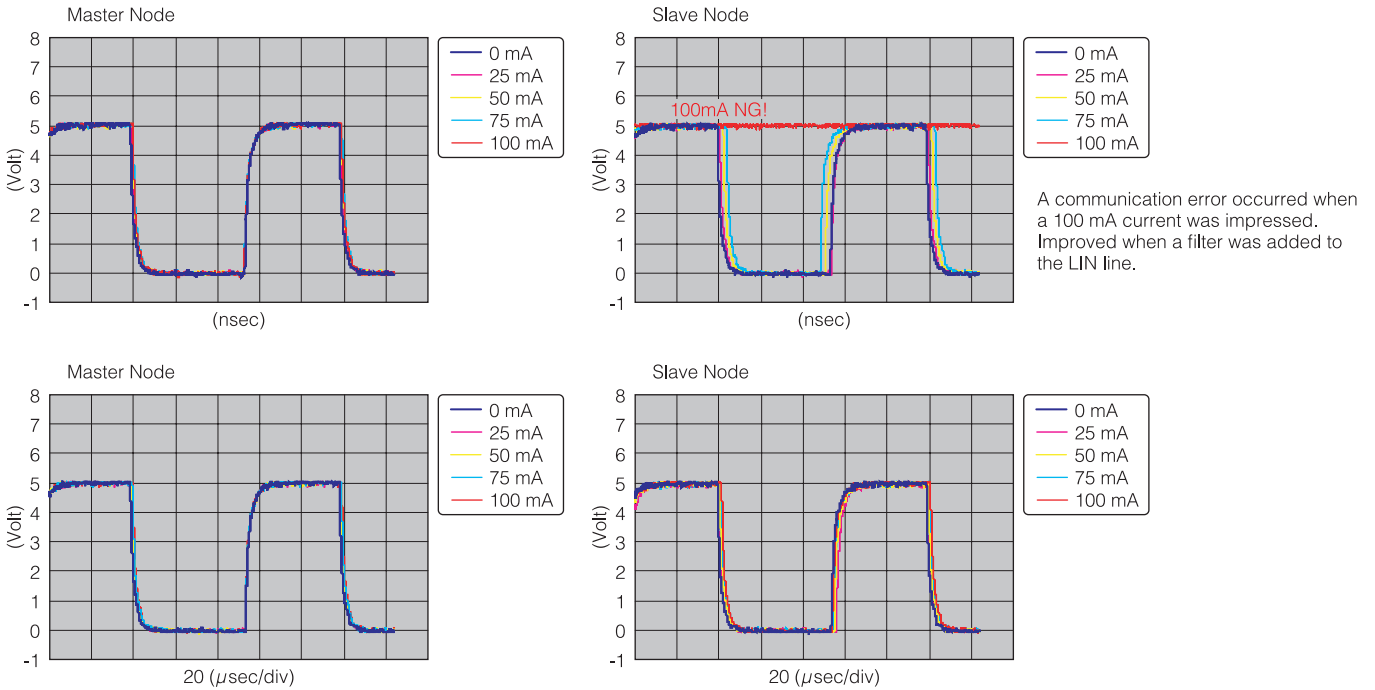

## 8 | Conclusion

As explained in the above, technology for improving the EMC of vehicle devices is important so that devices can operate correctly. In the future, the number of wireless devices will continue to increase as functions become more advanced, which will mean that technology for improving EMC will become even more important. The components explained in this material have an auxiliary role of improving EMC, but they are very effective. TDK will continue to develop products based on evaluation data related to vehicle communication networks so that various requirements can be met. There are other noise countermeasure examples that could not be explained here, so please ask for more information.