

# Circuit Simulation and Technical Support Tools

TDK Corporation Application Center  
Tetsuya Umemura, Katsushi Ebata

## 1 | Utilization of Computer Simulation

In recent years, computer simulation has been actively introduced in the areas of circuit design and equipment design; simulation saves considerable time and money compared to actually producing experimental circuits and equipment and repeating tests. The increased power and performance of both hardware and software, enabling much faster complex computation is also a factor promoting its popularization.

## 2 | Accuracy Improvement of Computer Simulation

Although the use of computer simulation seems to have been spreading as mentioned above, there are those engineers who question its validity on the grounds that “the actual results do not match the simulation results”. Although it may be true that “God is the only one” who can really know, it can also be said that computer simulation in recent years has made considerable advances as a tool for understanding the outline of phenomena.

There are two prominent factors that affect the reliability of computer simulation; one is the computational principle, the so-called “computational engine”, and the other is the “modeling technique”.

A “computational engine” is a system for enabling computational calculation created by the innovative efforts of each simulator manufacturer, based on principles derived from past experiences. The results and computation time varies according to each computational engine, even when performing a simulation of the same circuit.

“Modeling techniques” tend to depend largely on the user of the simulator. If the model to be simulated is not close to reality, the result will mirror this, even if the computational engine is

excellent. However, a high level of expert knowledge and experience are required in order to master modeling techniques.

Let’s take an example of a ceramic capacitor. A comparative example of impedance characteristics between the actual measurement data of a ceramic capacitor (0.1  $\mu\text{F}$ ) and the model data computed based on the “equivalent circuit model” is shown in Figure 1. Whereas results of all models match that of the actual measurement regarding  $|Z|$  characteristic, it is clear that model 1’s result regarding ESR (Equivalent Series Resistance) characteristic do not match the actual measurement data. Although capacitors are modeled as  $-|$  in circuit simulators, components such as resistance components and inductance components are included in the actual capacitor, and without the use of a model that reflects those components more accurately, the result may be that “the results of simulation and actual measurement do not match”. However, caution is needed when setting up a simulation, for if too many complex models are used in order to pursue computational accuracy, computing time will be considerably extended.

Figure 1 Comparative Examples of Actual Measurement and Models regarding Ceramic Capacitor (0.1  $\mu\text{F}$ )

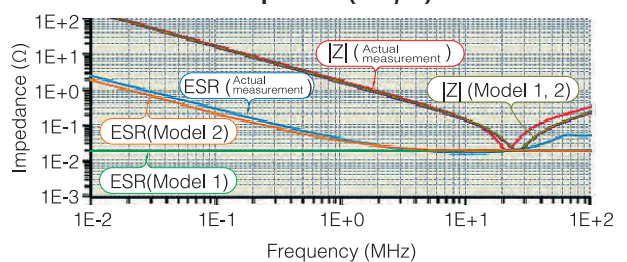

Table 1 TDK Technical Support Tools

| Classification                                       | Name   | Outline  |
|--|--|--|
| Windows® application                                 | Component characteristic analysis software “SEAT”    | Sophisticated applications such as display of component characteristics, pulse response simulation, and display of DC bias/temperature characteristics |
| Web application                                      | Components characteristic viewer “CCV”               | Display and compare data such as a component’s frequency characteristics and DC bias/temperature characteristics on the browser                        |
| General purpose electronic component models          | S-parameter Data Library                             | Collective data of actual measured S-parameters  |
|  | Equivalent Circuit Model Library                     | Collective data of equivalent circuit models in PDF format   |
|  | SPICE Netlist Library                                | Collective data of equivalent circuit models in netlist format   |
| Dedicated electronic component models for simulators | Component Library for Agilent ADS                    | Equivalent circuit models, circuit schematic symbols and footprint data of the components  |
|  | Component Library for Ansoft Designer® & NEXXIM®     |  |
|  | Component Library for Zuken CR-5000 Lightning        |  |
|  | Component Library for Cadence Allegro® PCB SI        | Equivalent circuit models of the components  |
|  | Component Library for Cadence Allegro® PCB PI option |  |

### 3 | TDK Technical Support Tools

In order to respond to various modeling needs TDK Technical Support Tools provide many electronic component models and the software for utilizing them. The contents of TDK Technical Support Tools at this writing are shown in Table 1. They are based on general purpose electronic component models (S-parameters and equivalent circuits), and the component characteristic analysis software "SEAT" and the components characteristic viewer "CCV" are software developed to display characteristics and perform simple circuit simulations using information on general purpose electronic component models. General purpose electronic component models were processed into dedicated models for simulators, so that they could be easily used by each simulator, ensure ease of arrangements from the component palette attached to the simulator, or ensure their footprint information can be obtained in combination with the CAD function. All tools/models can be used for free.

Website of technical support tools  
<http://www.tdk.co.jp/etst/index.htm>

### 4 | Component Characteristic Analysis Software "SEAT"

Screen shot of the component characteristic analysis software "SEAT" is shown in Figure 2.

Main functions of "SEAT" are as below:

- Several thousand components such as coils, capacitors, beads, 3-terminal filters, common mode filters, varistors, NTC thermistors and baluns are included.
- Display of characteristics such as impedance and S-parameters
- Pulse response simulation
- TDR simulation
- DC bias/temperature characteristics simulation
- User-defined filter (tool for combining multiple components)
- User-defined component
- Characteristic impedance computation tool (tool for computing characteristic impedance from physical dimensions of the transmission line)

When using "SEAT", it is not only possible to display frequency characteristics, but also to check the component's effect through pulse response simulation, or to estimate the degree of characteristic change that will happen upon application of DC bias, or under any given temperature conditions.

**Figure 2** Screen Shot of the Component Characteristic Analysis Software "SEAT"

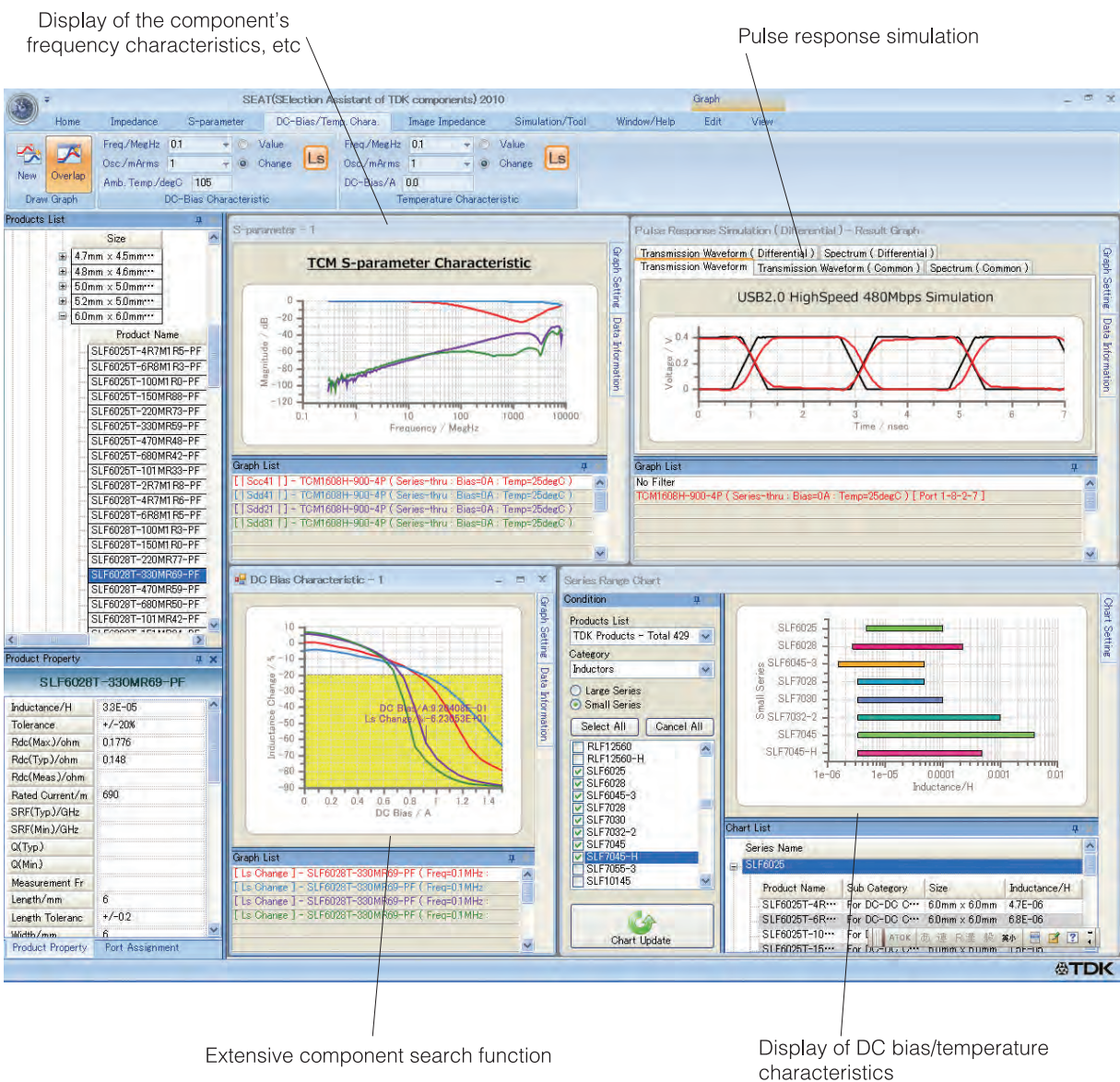

Ferrite beads are a typical noise countermeasure component and Figure 3 gives the computation results of pulse response simulation showing their influence on transmission waveform. Voltage waveforms on the side of the receiver are displayed, the result without a filter are in black line, and the results when two different ferrite beads were inserted right after the driver are shown in red and blue lines. Since ringing waveforms such as those displayed in blue line may appear and cause adverse effects depending on circuit conditions, it is possible to save time and reduce costs, by using tools such as “SEAT” to narrow down the target in advance.

SEAT website

<http://www.tdk.co.jp/eseat/index.htm>

**Figure 3 Effect Example of Ferrite Beads in Pulse Response Simulation (Single End)**

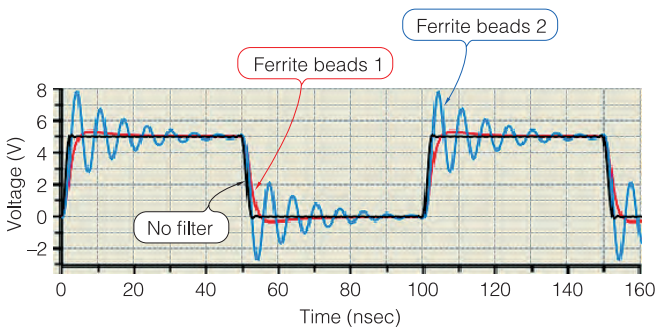

**Figure 4 Screen Shot of Components Characteristic Viewer “CCV”**



## 5 | Components Characteristic Viewer “CCV”

Screen shot of the components characteristic viewer “CCV” is shown in Figure 4. Although “CCV” is not equipped with the simulation function included in “SEAT”, it is characterized by the fact that frequency characteristics and DC bias/temperature characteristics can be displayed on the browser.

It is also very easy to operate, and you will be able to display the component characteristics by selecting the component and using the wizard (three steps). In concrete terms, take the following steps as shown in Figure 5:

Step 1: Select the component category

Step 2: Narrow down the target product (no need to enter, if narrowing down is not necessary)

Step 3: Select a component from the component list on the left side of the screen

When the above steps are taken, the component characteristics will be displayed on the right side of the screen. Graphs will be overlaid when selecting another component, making it easy to perform comparative evaluation.

As “CCV” is an easy-to-operate web application without any need of installation, we strongly recommend its use for selecting components.

CCV website

<http://www.tdk.co.jp/ccv/index.asp>

Figure 5: Three Steps of CCV

Step 1: Selecting the category



Step 2: Narrowing down



Step 3: Display of product characteristics

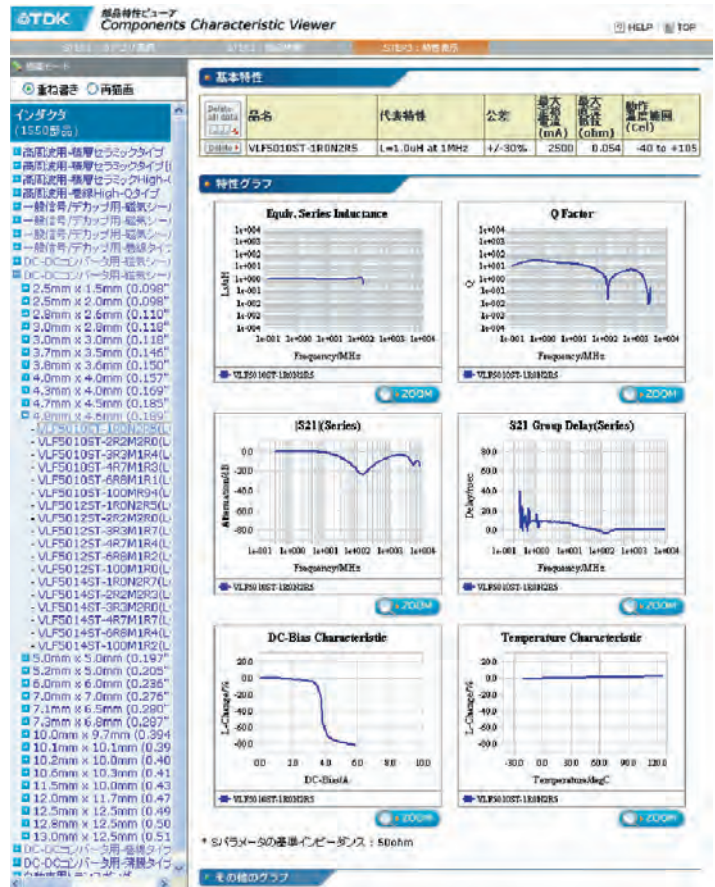

## 6 Electronic Component Models for Circuit Simulation “TVCL”

When designing electronic circuits using circuit simulation, simulation models for various factors making up the circuit (semiconductors, passive components, connectors, substrate traces, etc.) are necessary. TDK provides circuit simulation models of various electronic components (TDK Virtual Component Library). The contents are introduced below:

### Characteristics of TDK’s Electronic Component Models for Circuit Simulator

- Various products included

Numerous general purpose passive electronic components of TDK are included, such as capacitors, inductors, ferrite beads, common mode filters, 3-terminal filters, pulse transformers, varistors, baluns, etc.

- Compatibility with circuit simulators

In order to be compatible with circuit simulators, we have

prepared eight libraries such as those shown in the lower half of Table 1. Among these, the general purpose component models were created in a general purpose format, so that they can be used by various circuit simulators. Also, dedicated electronic component models for simulators are created exclusively for a specific circuit simulator, with data such as circuit schematic symbols and footprints included, in addition to equivalent circuit model data.

- We provide the latest models via the Internet

All models are provided via the Internet.

The URLs are as follows:

Japanese site <http://www.tdk.co.jp/tvcl/>

English site <http://www.tdk.co.jp/etvcl/>

### Contents of Each Library

TDK’s electronic component models for circuit simulators consist of nine libraries, making it possible to select the optimum library according to factors such as the circuit simulator to be

used and the purpose. The contents of each library are introduced below:

- S-Parameter Data Library

This is collective data based on actual measured S-Parameters. It is written in the widely common Touchstone format, and can be read directly by many simulators. (See Figure 6)

**Figure 6 An Example of S-Parameter Data Library**

```
! Port assignments
! 1 ---@@@--- 2
!
! Measurement condition
! Operating Temperature = 25 Cel
! DC Bias Current = 0 A
!
! TDK Corporation
!
# MHz S MA R 50
0.0000 0.0010 -0.0000 0.9991 -0.0000 ...
0.3000 0.0602 -84.612 0.9947 -3.4358 ...
0.3141 0.0628 -85.264 1.0005 -3.5931 ...
0.3289 0.0677 -85.119 0.9990 -4.1515 ...
.
<中略>
.
8500.0 0.3809 -120.98 0.8349 -35.585 ...
```

- Equivalent Circuit Model Library

Equivalent circuit model is a circuit for duplicating the frequency characteristics of an actual component by the circuit simulator. Data of equivalent circuit models are written in PDF format in the Equivalent Circuit Model Library (See Figure 7).

**Figure 7 An Example of Equivalent Circuit Model Library**

TDK Equivalent Circuit Model Library  
Common Mode Filters / ACM2012 Series  
Mar. 01, 2007

**Circuit Diagram**

1 ---@@@--- 4  
2 ---@@@--- 3

**Circuit Parameters**

| Part No.        | [R1]ohm | [L1]uH | [C1]pF | [R2]ohm | [L2]uH | [C2]pF | [R3]ohm | [L3]uH | [C3]pF | [R4]ohm | [L4]uH | [C4]pF | [R5]ohm | KC |
|-----------------|---------|--------|--------|---------|--------|--------|---------|--------|--------|---------|--------|--------|---------|----|
| ACM2012-900-2P  | 14      | 3.3    | 0.84   | 800     | 200    | 0.02   | 0.065   | 1      | 0.95   | 1       | 0.95   | 1      | 0.95    | 1  |
| ACM2012-1210-2P | 13      | 3.3    | 0.93   | 1200    | 260    | 0.2    | 0.075   | 1      | 1      | 1       | 1      | 1      | 1       | 1  |
| ACM2012-200-2P  | 14      | 3.3    | 0.82   | 1000    | 440    | 0.03   | 0.085   | 1      | 1.07   | 1       | 1.07   | 1      | 1.07    | 1  |
| ACM2012-360-2P  | 17      | 3.3    | 1.13   | 2700    | 835    | 0.03   | 0.095   | 1      | 2.03   | 1       | 2.03   | 1      | 2.03    | 1  |

© TDK Corporation, 2007. All Rights Reserved.

- SPICE Netlist Library

Data of equivalent circuit models are written in the SPICE netlist format. Since a general purpose SPICE format is used, this library can be read directly by many simulators. (See Figure 8)

**Figure 8 An Example of SPICE Netlist Library**

```
*-----
* SPICE Netlist Generated by TDK Corporation
* TDK P/N: ACM2012-900-2P (Common Mode Filter)
* Property: Zc(at 100MHz) = 90 [ohm]
* Model Generated on Dec. 04, 2006
*-----
* External Node Assignments:
*
* 1 ---@@@--- 4
* 2 ---@@@--- 3
*
*-----
.SUBCKT ACM2012_900_2P 1 2 3 4
C11 11 12 0.84p
C12 21 22 0.84p
C13 31 32 0.84p
C14 41 42 0.84p
C21 12 42 0.02p
C22 22 32 0.02p
C41 12 22 0.95p
C42 32 42 0.95p
.
<中略>
.
R42 32 42 1G
R51 1 4 1G
R52 2 3 1G
.ENDS ACM2012_900_2P
*-----
```

- Component Library for Agilent ADS

This library is to be used with ADS of Agilent Technologies. Data of circuit schematic symbols and footprints are included, in addition to the equivalent circuit model data. It is also compatible with the Discrete Optimize function of ADS, making it possible to automatically select the optimum component. (See Figure 9)

**Figure 9 An Example of Electronic Component Model for Agilent ADS**

Term1 Num=1 Z=50 Ohm  
Term2 Num=2 Z=50 Ohm  
Term3 Num=3 Z=50 Ohm  
Term4 Num=4 Z=50 Ohm

TDK\_TCM1210H\_1  
Name=TCM1210H\_100\_2P

NETLIST INCLUDE  
S-PARAMETERS

S\_Param  
SP1  
Start=300 kHz  
Stop=6 GHz  
Dec=50

- Component Library for Ansoft Designer® & NEXXIM®

This library is to be used with Ansoft Designer and NEXXIM of Ansoft Corporation. Data of circuit schematic symbols and footprints are included, in addition to the equivalent circuit model data. (See Figure 10)

- Component Library for Zuken CR-5000 Lightning

This library is to be used with Zuken Inc.'s CR-5000 Lightning. Data of circuit schematic symbols and footprints are included, in addition to the equivalent circuit models of common mode filter. (See Figure 11)

- Component Library for Cadence Allegro® PCB SI

This library is to be used with Cadence Allegro PCB SI of Cadence Design Systems, Inc. Equivalent circuit models of common mode filter and ferrite beads are included.

**Figure 10 An Example of Electronic Component Model for Ansoft Designer® & NEXXIM®**

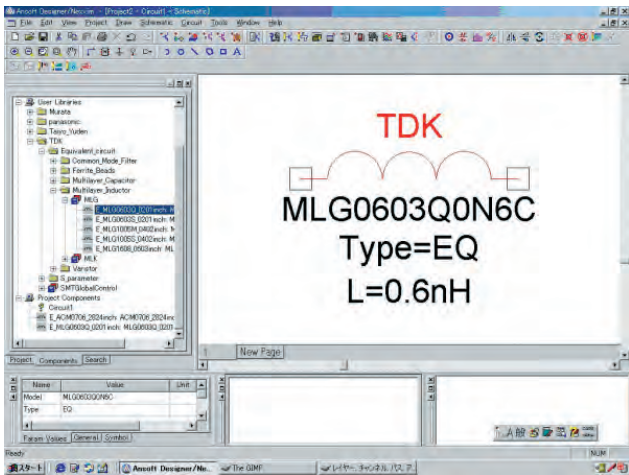

**Figure 11 An Example of Electronic Component Model for Zuken CR-5000 Lightning**

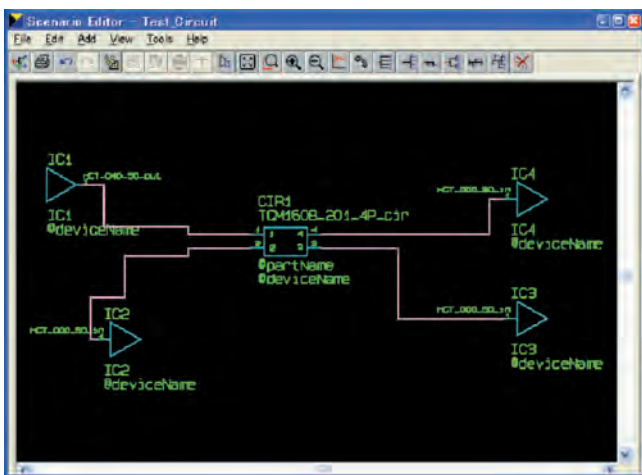

- Component Library for Cadence Allegro® PCB SI option

This library is to be used with Cadence Allegro PCB SI option of Cadence Design Systems, Inc. Equivalent circuit models of laminated ceramic capacitors are included. (See Figure 12)

**Figure 12 An Example of Cadence Allegro® PCB PI Option**

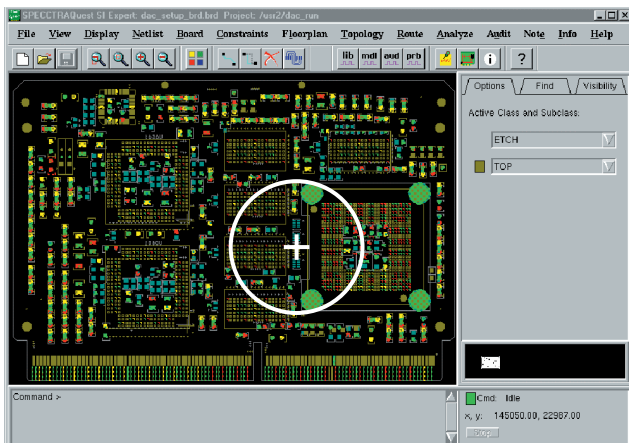

## ■ Comparison of Equivalent Circuit Models and Actual Measurement Values

As the characteristics of the materials making up the electronic components and the internal structure of the components themselves are taken into consideration in TDK's equivalent circuit models, it is possible to duplicate the characteristics of the actual components in detail. The comparative results of impedance characteristics regarding ferrite beads (MMZ1005D121C) between the equivalent circuit model and the actual measurement value are shown in Figure 13. It can be seen that for a wide range of frequencies the equivalent circuit model duplicates the behavior of the actual component very well. In order to have reliable circuit simulation results, it is essential to use such highly accurate simulation models.

**Figure 13 Comparison of Equivalent Circuit Models and Actual Measurement Values (MMZ1005D121C)**

(a) Impedance components ( $|Z|$ )

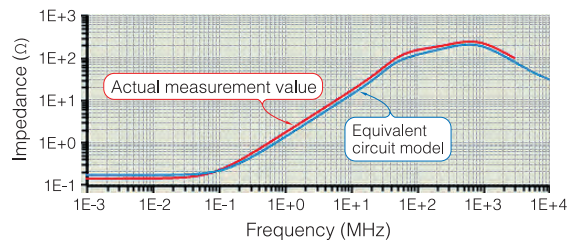

(b) Resistance component, reactance component

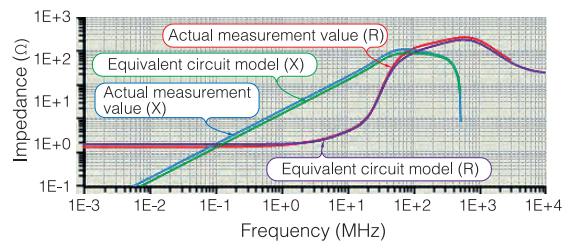

## 7 | Conclusion

We have here introduced technical support tools provided by TDK. We hope you will utilize them for purposes such as electronic circuit design and EMC countermeasures. Ansoft Designer® and NEXXIM® are registered trademarks of Ansoft Corporation. Allegro® is the registered trademark of Cadence Design Systems, Inc.

Other company names and product names described are registered trademarks or trademarks of each company.