

CONNECTORS USED:

PART DESCRIPTION	PART NAME	MANUFACTURER	QTY
PIN HEADER (INPUT SIDE CN1)	B3P5-VH	J.S.T	1
PIN HEADER (OUTPUT SIDE CN2)	B6P-VH	J.S.T	1

ACCESSORIES:

SOCKET HOUSING (CN1)	VHR-5N	J.S.T	1
SOCKET HOUSING (CN2)	VHR-6N	J.S.T	1
TERMINAL PINS (CN1,2)	SVH-21T-P1.1	J.S.T	8

HAND CRIMPING TOOL : YC-16 MANUFACTURER : J.S.T

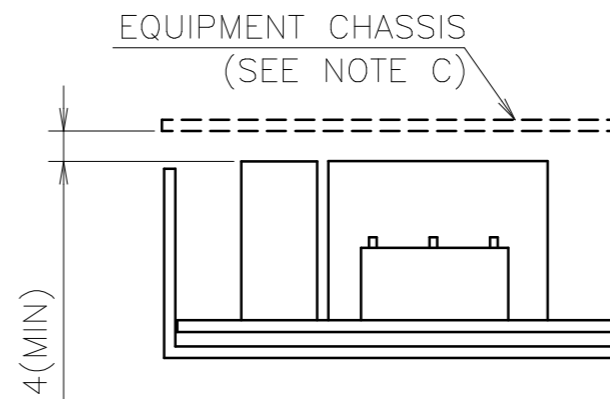

NOTE

- A: MODEL NAME, INPUT VOLTAGE RANGE, NOMINAL OUTPUT VOLTAGE, MAXIMUM OUTPUT CURRENT, COUNTRY OF MANUFACTURE AND SAFETY MARKING (FOR ONLY APPROVED PRODUCTS) ARE SHOWN HERE IN ACCORDANCE WITH THE SPECIFICATIONS.
- B: MOUNTING HOLES (2X2 PLACES) FOR M3 SCREWS. SHOULD NOT ENTER THE POWER SUPPLY SURFACE BY MORE THAN 4mm RECOMMENDED TORQUE IS 0.49N·m.
- C: UNIT MUST BE INSTALLED WITH EQUIPMENT CHASSIS AT LEAST 4mm FROM MAXIMUM HEIGHT (27mm) OF THE UNIT. OTHERWISE BASIC INSULATION MATERIAL IS REQUIRED.

(unit : mm)

MODEL	LWT15H
TDK-Lambda	

PA785-02-01I