

CONNECTORS USED:

PART DESCRIPTION	PART NAME	MANUFACTURER	QTY
PIN HEADER (INPUT SIDE CN1)	B3P5-VH	JST	1
PIN HEADER (OUTPUT SIDE CN2)	B7P-VH	JST	1

ACCESSORIES:

SOCKET HOUSING (CN1)	VHR-5N	JST	1
SOCKET HOUSING (CN2)	VHR-7N	JST	1
TERMINAL PINS (CN1,2)	SVH-21T-P1.1	JST	10

HAND CRIMPING TOOL : YC-16 MANUFACTURER : JST

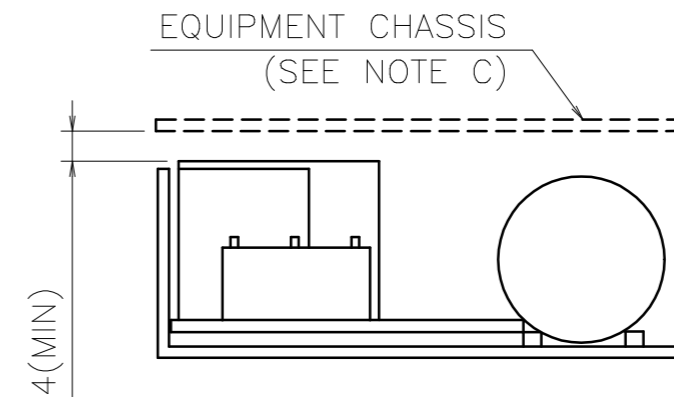

NOTE

- A: MODEL NAME, INPUT VOLTAGE RANGE, NOMINAL OUTPUT VOLTAGE, MAXIMUM OUTPUT CURRENT, COUNTRY OF MANUFACTURE AND SAFETY MARKING (FOR ONLY APPROVED PRODUCTS) ARE SHOWN HERE IN ACCORDANCE WITH THE SPECIFICATIONS.
- B: MOUNTING HOLES (2X2 PLACES) FOR M3 SCREWS. SHOULD NOT ENTER THE POWER SUPPLY SURFACE BY MORE THAN 4mm RECOMMENDED TORQUE IS 0.49N·m.
- C: UNIT MUST BE INSTALLED WITH EQUIPMENT CHASSIS AT LEAST 4mm FROM MAXIMUM HEIGHT (27mm) OF THE UNIT. OTHERWISE BASIC INSULATION MATERIAL IS REQUIRED.

(unit : mm)

MODEL	LWT30H
TDK-Lambda	

PA786-02-011