

HFE3500

3500W 1U Hot Swap Front End Industrial Power Supplies Application Note



CHAPTER 1:	HFE3500 SERIES SPECIFICATIONS	2
1.1	HFE3500 rated output Power versus Line Voltage.	2
1.2	HFE3500 Output Power vs. Temp derating.....	2
1.3	HFE3500 Output Current vs. Temp derating.....	3
1.4	HFE3500 Outline Drawing.....	4
1.5	Rear Panel IN/OUT Connector Pins Function Description.....	5
CHAPTER 2:	SINGLE UNIT OPERATION	6
2.1	Front Panel Indicators.....	6
2.2	Single unit operation.....	7
2.2.1	Basic configuration (Local Sense)	7
2.2.2	Basic configuration (Remote Sense).....	7
2.2.3	ON/OFF Control by Enable.....	8
2.2.4	ON/OFF Control by INHIBIT	8
2.2.5	OUTPUT VOLTAGE PROGRAMMING by External Potentiometer	8
2.2.6	Output Voltage Programming by External Voltage	9
2.2.7	Output Voltage Programming by PMBus	9
2.2.8	Hiccup OCP Threshold Programming by External Voltage	10
2.2.9	Hiccup OCP Threshold Programming by PMBus.....	10
2.2.10	Hiccup OCP Threshold Programming by External Potentiometer.....	10
2.2.11	SUPERVISORY Signals (Typical Connection).....	11
CHAPTER 3:	POWER SUPPLIES CONNECTION	12
3.1	Parallel Operation	12
3.2	Series Operation.....	13
CHAPTER 4:	PMBus INTERFACE	14
4.1	HFE3500 Series I ² C Specification.....	14
4.1.1	PMBus Interface	16
4.1.2	HFE3500 Has Power Management Bus Hardware	16
4.1.3	Addressing (A3, A2, A1, A0 Inputs).....	16
4.1.4	Serial Clock.....	16
4.1.5	Serial Data.....	16
4.1.6	SMB Alert.....	17
4.1.7	PMBus Typical Connection	17
4.1.8	Packet Error checking	17
4.2	PMBus Command Set.....	18
4.2.1	Read Status	18
4.2.2	Clear Faults	18
4.2.3	Operation (ON/OFF)	18
4.2.4	Commands to Read Inventory Details	19
4.2.5	Restore User Settings to Factory Defaults (RESTORE_DEFAULT_ALL).....	19
4.2.6	Store Present User Settings (STORE_USER_ALL)	19
4.2.7	Restore Saved User Settings (RESTORE_USER_ALL)	19
4.3	Programming and Monitoring Functions.....	20
4.3.1	Monitoring Output Voltage (READ_VOUT).....	20
4.3.2	Monitoring Output Current (READ_IOUT).....	20
4.3.3	Monitoring Supply Temperature (READ_TEMPERATURE_1)	21
4.3.4	Programming Output Voltage (VOUT_COMMAND).....	21
4.3.5	Programmable Maximum Output Voltage (VOUT_MAX).....	21
4.3.6	Programming Hiccup OCP Current Threshold (MFR_ILIMIT_COMMAND). 22	

CHAPTER 1: HFE3500 SERIES SPECIFICATIONS

To improve the transient load performance, it is recommended that 1000µF, low ESR, electrolytic capacitance is fitted to the main output in the customer application.

1.1 HFE3500 rated output Power versus Line Voltage.

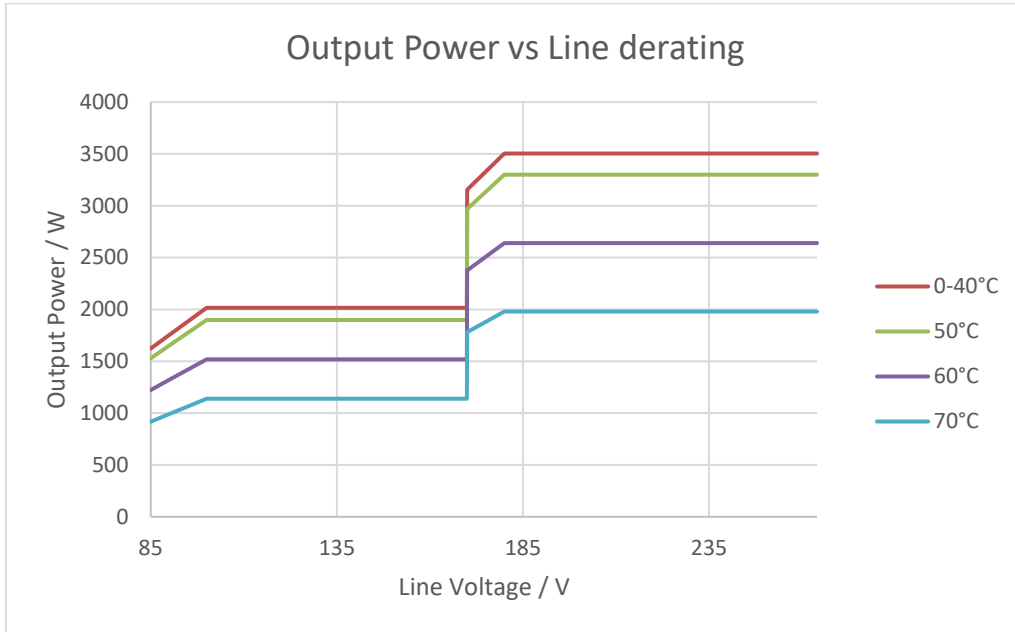

Figure 1–1: HFE3500-24 and 48

1.2 HFE3500 Output Power vs. Temp derating

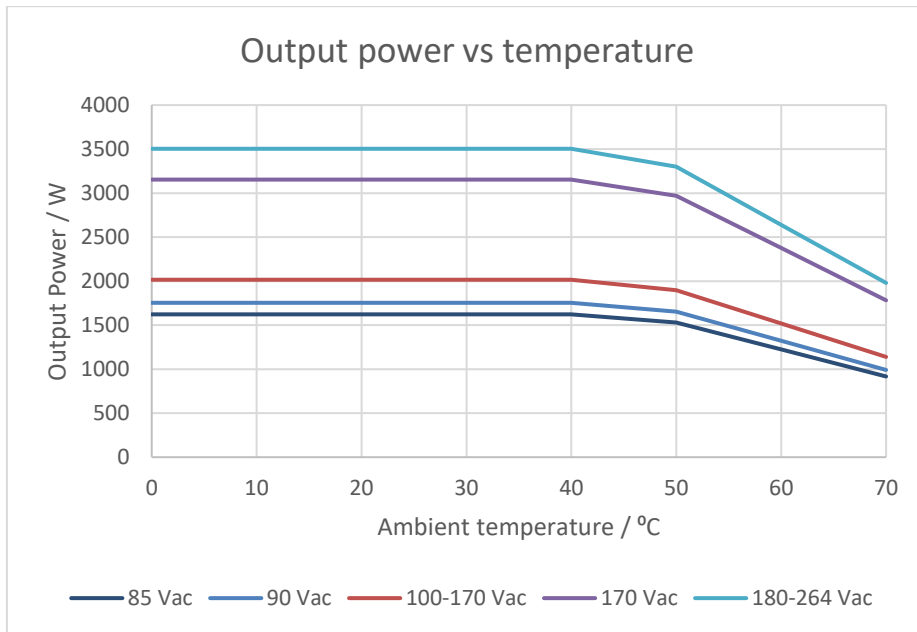

Figure 1–2: HFE3500-24 and 48

1.3 HFE3500 Output Current vs. Temp derating

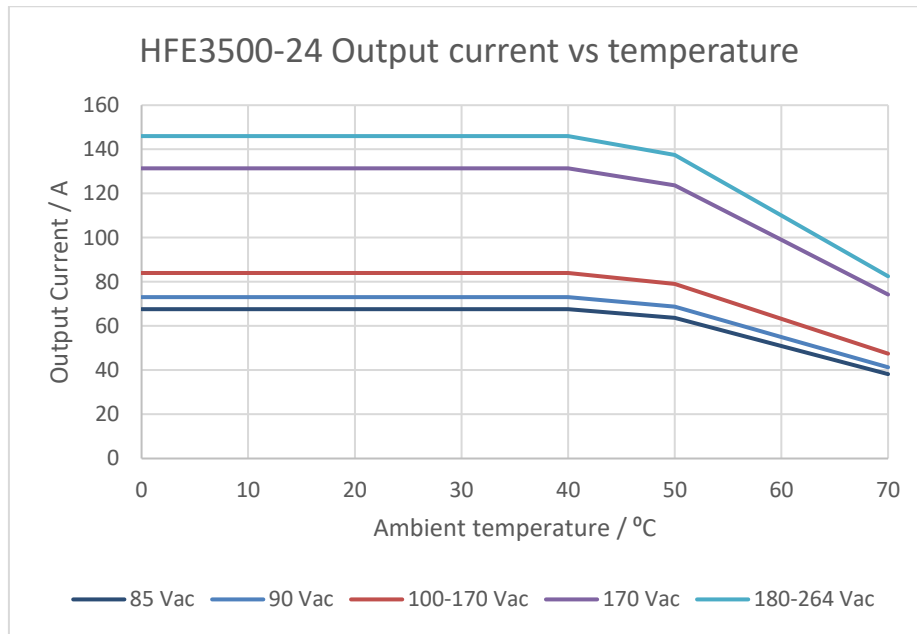

Figure 1-3: HFE3500-24

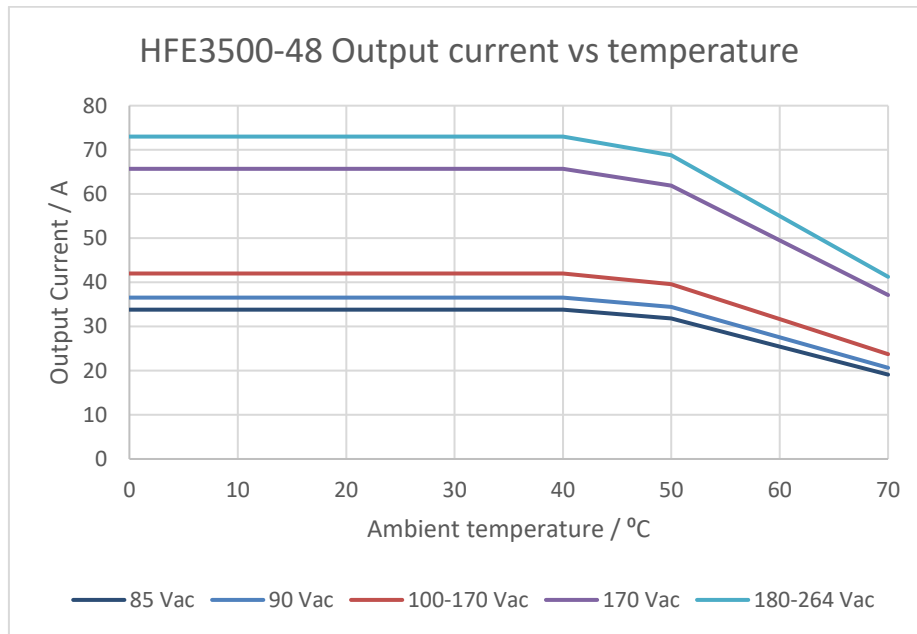
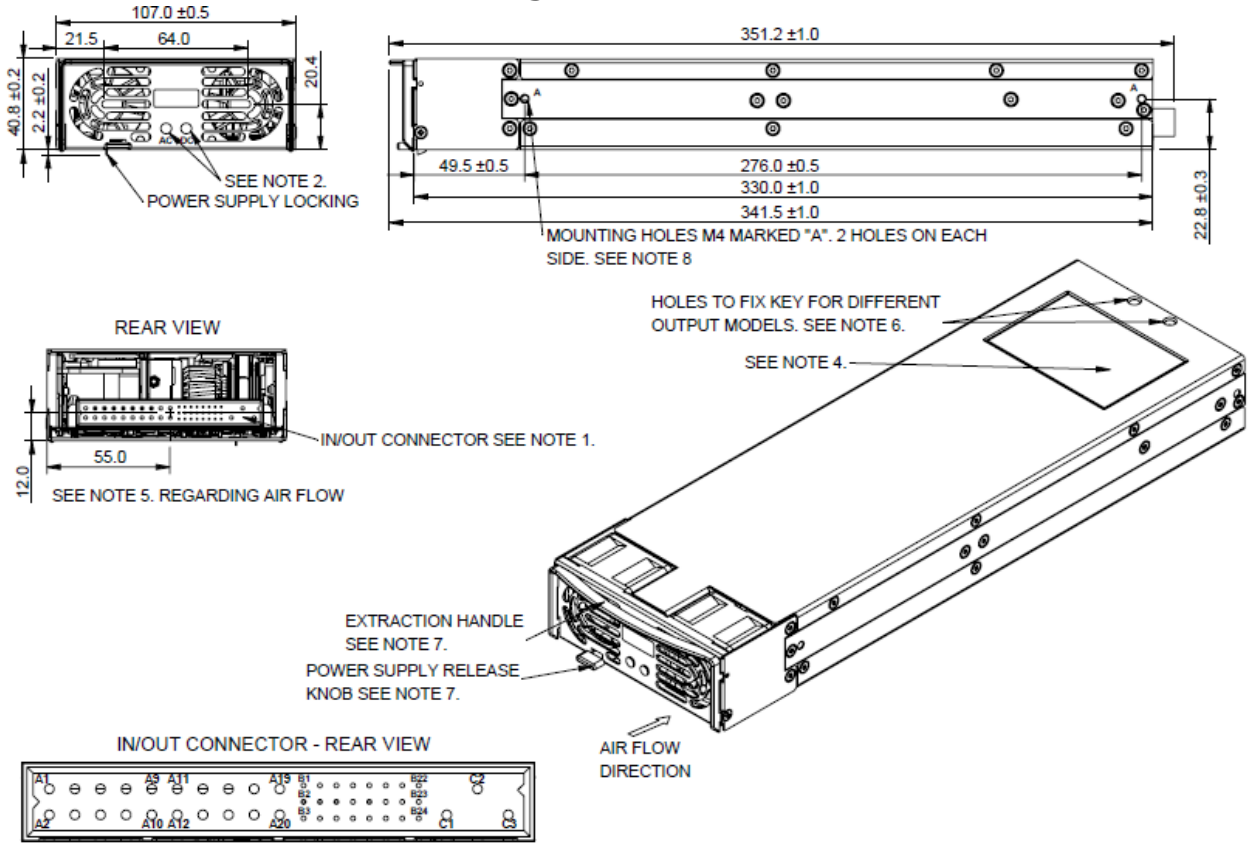

Figure 1-4: HFE3500-48

1.4 HFE3500 Outline Drawing



PIN No.	FUNCTION	PIN No.	FUNCTION
A1 - A10	-VO	B14	A1
A11 - A20	+VO	B15	DC_OK
B1	SIGNAL_RTN	B16	AD
B2	PS_EXIST	B17	SDA
B3	+V_STBY (NOTE 3)	B18	TEMP_ALARM_SR
B4	-SENSE	B19	V_REF_EXT
B5	A2	B20	SMB_ALERT
B6	CS	B21	AC_FAIL_OUT
B7	ENABLE	B22	5V_TRIM
B8	V_PROG	B23	NC
B9	+SENSE_IN	B24	NC
B10	A3	C1	EARTH
B11	I_PROG	C2	NEUTRAL
B12	INHIBIT	C3	LINE
B13	SCL		

- NOTES:
- CONNECTOR TYPE: PCIH47M400/A1, POSITRONIC. MATES WITH FEMALE CONNECTOR TYPE: PCIH47F400A1/AA.
 - LED INDICATORS: REFER TO INSTRUCTION MANUAL.
 - +V_STBY: /F = +5V, /T = +12V (REFER TO INSTRUCTION MANUAL)
 - MODEL NAME, INPUT AND OUTPUT RATING AND SAFETY APPROVAL SYMBOLS ARE DESCRIBED ON TOP SURFACE LABEL.
 - ALLOW MINIMUM 50mm OF FREE AIR OUTLET AT THE REAR OF THE UNIT. DO NOT OBSTRUCT AIR FLOW TO THE FRONT PANEL.
 - REFER TO INSTRUCTION MANUAL FOR SETTING DETAILS
 - TO EXTRACT POWER SUPPLY, ELEVATE THE RELEASE KNOB AND PULL THE EXTRACTION HANDLE.
 - MOUNTING SCREWS MUST NOT PENETRATE MORE THAN 7mm INTO THE UNIT.

1.5 Rear Panel IN/OUT Connector Pins Function Description

Pin #	Function	Description	Referenced to
A1~A10	-V	Main Negative Output Voltage.	
A11~A20	+V	Main Positive Output Voltage.	
B1	SIGNAL RETURN	Return for the following control signals: ENABLE, INHIBIT; Supervisory signals: TEMP ALARM, AC FAIL, AUX, DC OK and PS EXIST. PMBus signals: SCL, SDA and SMB ALERT. SIGNAL RETURN and mentioned signals are isolated from the output terminals and -SENSE.	
B2	PS EXIST	Indicates that Power Supply module is inserted into the shelf. "Active Low".	SIGNAL RETURN
B3	+AUX OUT	Auxiliary Voltage Output. Voltage and current rating dependent on the selected standby option. This output has a built in O-Ring diode. Not affected by the INHIBIT/ENABLE signal or any other fault.	SIGNAL RETURN
B4	-SENSE	Negative sense. The -SENSE signal should be connected to -V on Power Supply or Load side.	-SENSE
B5,B10,B14,B16	A2,A3,A1,A0 (PMBus)	PMBus Address lines. Refer to Section 4.1.3 for Addressing.	-SENSE
B6	CURRENT SHARE	Current sharing signal should be connected when Power Supplies are connected in parallel, to allow accurate current share between units.	-SENSE
B7 (short pin)	ENABLE	Turns ON the main output by electrical signal or dry contact. ON: 0~0.6v or short; OFF: open. Requires the "ENABLE" signal to be connected to "Signal Return"	SIGNAL RETURN
B8	VOLTAGE PROGRAMMING	Input 0~5V. Provides Vout programming by Voltage. Refer to Section 2.2.5; Section 2.2.6 and Section 2.2.7.	-SENSE
B9	+SENSE	Positive sense. The +SENSE signal should be connected to +V on Power Supply or Load side.	+SENSE
B11	HICCUP OCP CURRENT PROGRAMMING	Input 0~5V. Provides Hiccup OCP Current Threshold Programming by Voltage. Refer to Section 2.2.8 and Section 2.2.9.	-SENSE
B12	INHIBIT	Turns OFF the main output by electrical signal or dry contact. OFF: 0~0.6v or short; ON: open. Requires the "ENABLE" signal to be connected to "Signal Return"	SIGNAL RETURN
B13	SLC (PMBus)	Serial Clock signal. Refer to Section 4.1.4.	SIGNAL RETURN
B15	DC OK	DC OK signal. LOW when the output voltage is higher than 90% ± 5% of set Vout. Open collector type (15V, 10mA).	SIGNAL RETURN
B17	SDA (PMBus)	Serial Data signal. Refer to Section 4.1.5.	SIGNAL RETURN
B18	TEMPERATURE ALARM	TEMP ALARM signal. LOW when the internal temperature is within safe limit; HIGH approx. 10°C below Thermal shut down. Open collector type (15V, 10mA).	SIGNAL RETURN
B19	V_REF	Variable output for Voltage programming with PMBus.	-SENSE
B20	SMB ALERT (PMBus)	PMBus INTERRUPT signal. Refer to Section 4.1.6.	SIGNAL RETURN
B21	AC FAIL	AC FAIL Signal; LOW when the input voltage is 85Vac<Vin; HIGH when the input voltage is 85Vac>Vin. Open collector type (15V, 10mA).	SIGNAL RETURN
B22	+5V_TRIM	5V fixed output, 5mA	-SENSE
B23, B24	NOT CONNECTED		
C1 (long pin)	PROTECTIVE GROUND	AC GROUND. Refer to Instruction Manual.	
C2 (long pin)	AC NEUTRAL	AC NEUTRAL. Refer to Instruction Manual.	
C3 (long pin)	AC LINE	AC LINE. Refer to Instruction Manual.	

Table 1-1: Rear panel IN/OUT pins



Figure 1-5: IN/OUTPUT CONNECTOR POSITRONIC P/N: PCIH47M400A1/AA

CHAPTER 2: SINGLE UNIT OPERATION

2.1 Front Panel Indicators

1. DC OK – LED indicator:

GREEN Output Voltage is above $90\% \pm 5\%$ of set Output Voltage.

RED Output Voltage is below $90\% \pm 5\%$ of set Output Voltage.

2. AC OK – LED indicator:

GREEN Input Voltage (V_{in}) is above 85Vac.

OFF Input Voltage (V_{in}) is below 85Vac.

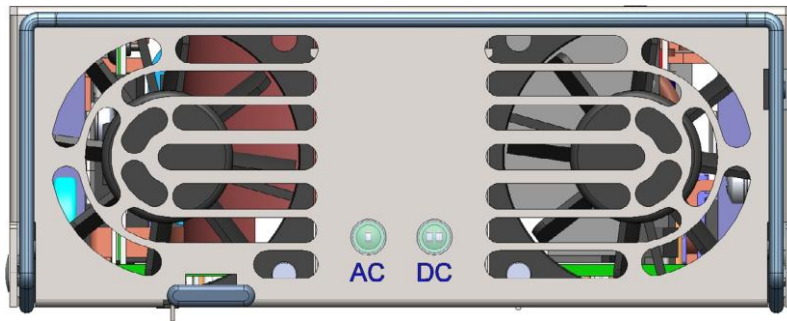

Figure 2–1: Front Panel Indicators

CAUTION:

When inserting a power supply into the rack, do not use unnecessary force; Slamming the power supply into the rack can damage the connectors on the rear of the supply and inside the rack.

ATTENTION:

Power supplies are factory programmed to the rated output voltage. For applications requiring an adjusted voltage, power supplies should be adjusted to the required voltage before connection to the load.

2.2 Single unit operation

2.2.1 Basic configuration (Local Sense)

- \pm SENSE have to be connected to the HFE3500 \pm V terminals prior to operating the supply.
- ENABLE input must be connected to SIGNAL RETURN in order for the supply to turn on.

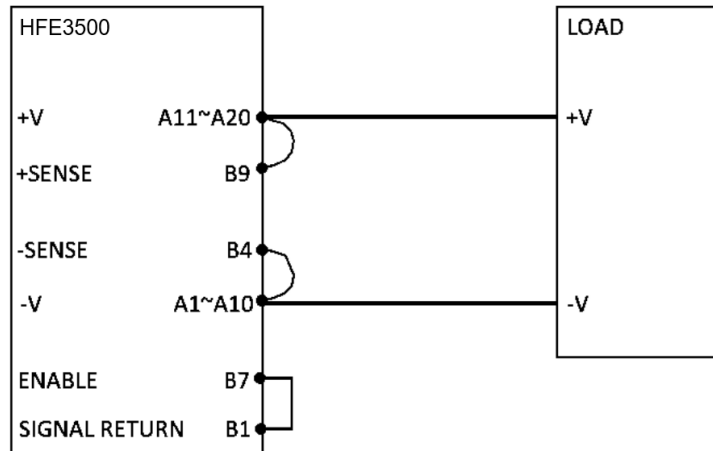

Figure 2-2: Local Sense Connection

2.2.2 Basic configuration (Remote Sense)

- \pm SENSE have to be connected to the \pm V terminals on the Load side prior to operating the supply.
- ENABLE input must be connected to SIGNAL RETURN in order for the supply to turn on.

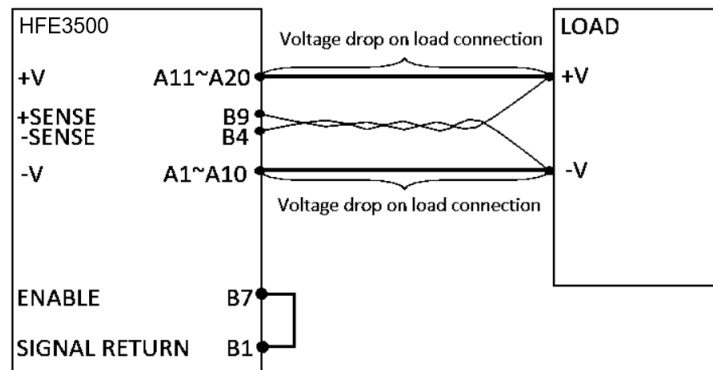

Figure 2-3: Remote Sense Connection

ATTENTION:

1. Maximum voltage drop on load connection:
HFE3500-24: 0.5V/wire; HFE3500-48: 1V/wire.
2. Twisted wires should be used for Remote Sensing connection.
3. If Remote Sensing is used, do not break Main Output connection.

2.2.3 ON/OFF Control by Enable

SIGNAL RETURN and ENABLE control are isolated from the output terminals and "-SENSE".

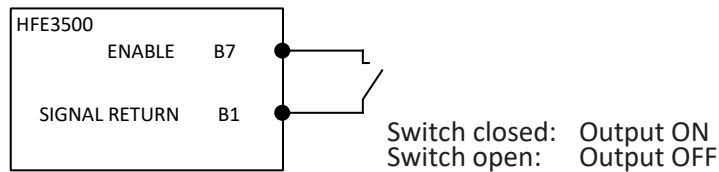

Figure 2-4: Control by ENABLE

2.2.4 ON/OFF Control by INHIBIT

Power Supply operation requires the "ENABLE" signal to be connected to "Signal Return".

Logic of the "INHIBIT" signal is reversed to logic of the "ENABLE" signal.

SIGNAL RETURN, INHIBIT and ENABLE controls are isolated from the output terminals and -SENSE.

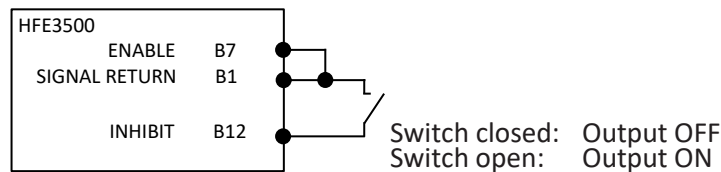

Figure 2-5: Control by INHIBIT

2.2.5 OUTPUT VOLTAGE PROGRAMMING by External Potentiometer

Output Voltage of HFE3500 Series can be trimmed by potentiometer between 100%-115% of nominal output voltage (For Output voltage limits see Graph below).

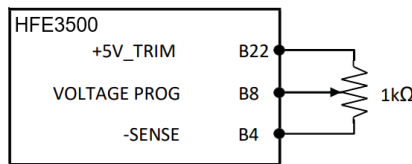

Figure 2-6: Control by Ex. Potentiometer

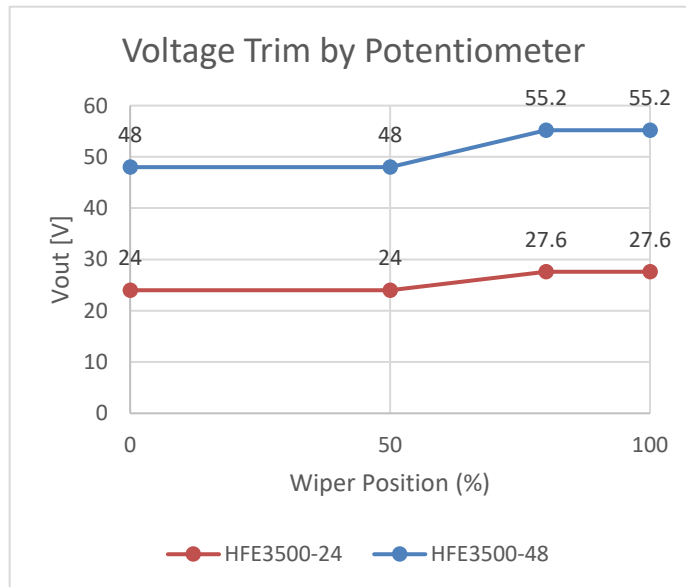

Figure 2-7: Output Voltage Limits

2.2.6 Output Voltage Programming by External Voltage

Output Voltage of HFE3500 Series can be programmed by external voltage source between 100%-115% of nominal output voltage
 (For Output voltage limits see Graph enclosed).

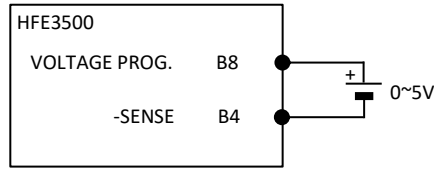

Figure 2-8: Control by Ex. Voltage

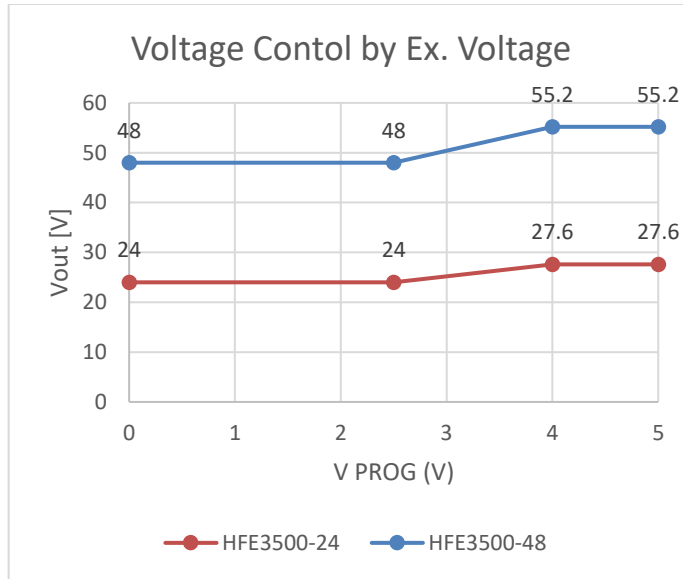

Figure 2-9: Output Voltage Limits

2.2.7 Output Voltage Programming by PMBus

Output Voltage of HFE3500 Series can be programmed by PMBus between 100%-115% of nominal output voltage.

ATTENTION:

If PMBus is used for voltage programming, the Reference voltage will not be fixed to 2.5V but variable (this reference signal was 5V default on the previous HFE2500 product).

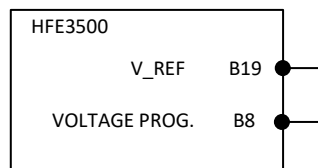

Figure 2-10: Programming by PMBus

2.2.8 Hiccup OCP Threshold Programming by External Voltage

The Hiccup mode Over Current Protection (OCP) output current threshold can be programmed by external voltage source 0~5V. Nominal OCP value is achieved by leaving the HICCUP_OCP_I_PROG pin unconnected, connecting the CURRENT PROG input to the internal 5V source (+5V_TRIM, B22) or connecting it to a 5V external voltage source. By changing the input programming voltage the OCP threshold current level can be decreased down to ~40% of Nominal Output Current. The OCP characteristic is Hiccup-mode.

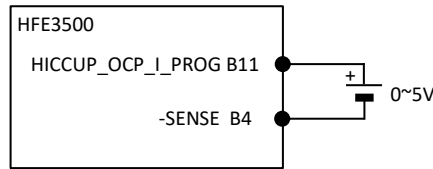

Figure 2–11: OCP Threshold Programming by Ext. Voltage

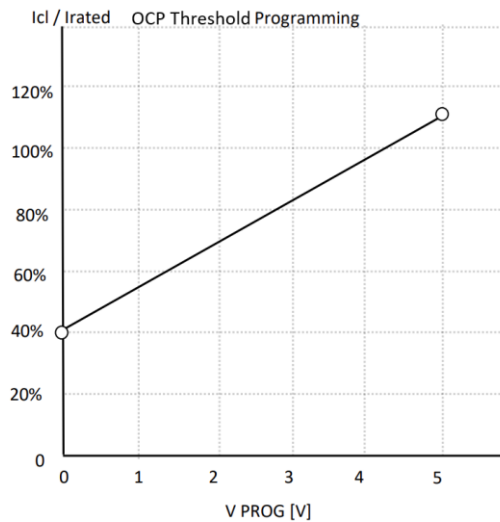

Figure 2–12: OCP Threshold Programming

2.2.9 Hiccup OCP Threshold Programming by PMBus

Hiccup Over Current Protection (OCP) threshold can be programmed by PMBUS in a range of 40% ~ 110% of Nominal Output Current. The PMBus Command internally overrides the OCP Threshold Programming set by Ext Voltage.

2.2.10 Hiccup OCP Threshold Programming by External Potentiometer

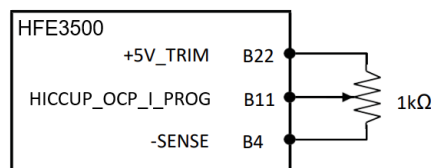

Figure 2–13: OCP Threshold Programming by Ext. Potentiometer

2.2.11 SUPERVISORY Signals (Typical Connection)

The following supervisory signals are accessible:

- DC OK
- AC FAIL
- PS EXIST
- TEMP ALARM

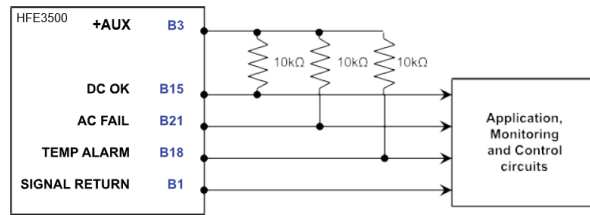

Figure 2–14: Signals

SIGNAL RETURN and mentioned signals are isolated from the output terminals and -SENSE.

These signals are Open Collector type (max 15V, max 10mA) shunted by internal 24V Zener, isolated from Output and referenced to “SIGNAL RETURN”.

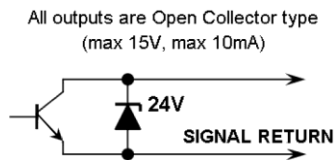
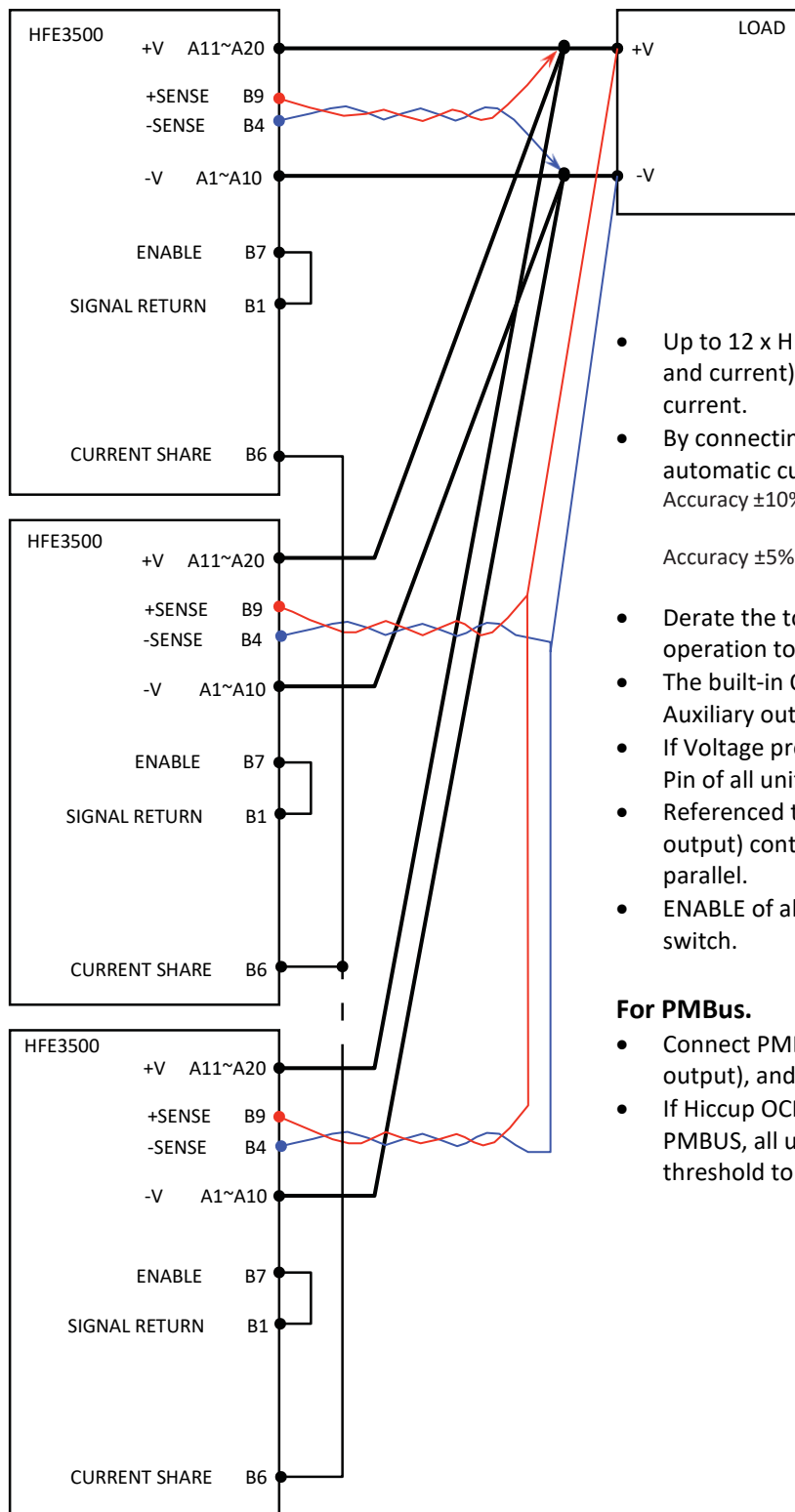

Figure 2–15: Open collector signals are shunted by internal 24V Zener

CHAPTER 3: POWER SUPPLIES CONNECTION

3.1 Parallel Operation



- Up to 12 x HFE3500 units with the same rating (voltage and current) can be used in parallel to increase the output current.
- By connecting the CS signal between the paralleled units, automatic current balance is achieved with accuracy of

Accuracy $\pm 10\%$:	20% \leq I _{out} < 50% of max I _{out} .
	Up to 12 units
Accuracy $\pm 5\%$:	I _{out} \geq 50% of max I _{out} .
	Up to 12 units.
- Derate the total output current by 5% when using parallel operation to prevent unit overload condition.
- The built-in O-Ring MOSFETs on the main output and the Auxiliary output allow N+1 operation.
- If Voltage programming is used, "Voltage Programming" Pin of all units must be connected in parallel.
- Referenced to "SIGNAL RETURN" (floating from the output) controls/signals and AUX can be connected in parallel.
- ENABLE of all supplies can be connected to a single switch.

For PMBus.

- Connect PMBus Signals in parallel (PMBUS is isolated from output), and choose different address for each unit.
- If Hiccup OCP Threshold Programming is done using PMBUS, all units need to be programmed to the same threshold to guarantee expected OCP performance.

Figure 3–1: Parallel Connection

3.2 Series Operation

- Up to 2 units with the same rating (voltage and current) can be used in series to increase the output voltage.
- Connect Main Output in series (as shown).
- Diodes should be connected in parallel with each unit output to prevent reverse voltage. Each diode should be rated to at least the power supply rated output voltage and output current.
- Connect as shown: +Sense of positive unit and –Sense of negative unit (twisted pair) to Load point, or to +V and –V accordingly for Local Sense.
- In case PMBus is used, Connect PMBus signals in parallel (PMBus is isolated from Output), and choose different address for each unit (see chapter 3).
- Output Voltage can be adjusted independently for each unit.
- Controls Monitoring signals and +AUX are referenced to “SIGNAL RETURN” and may be connected in parallel.

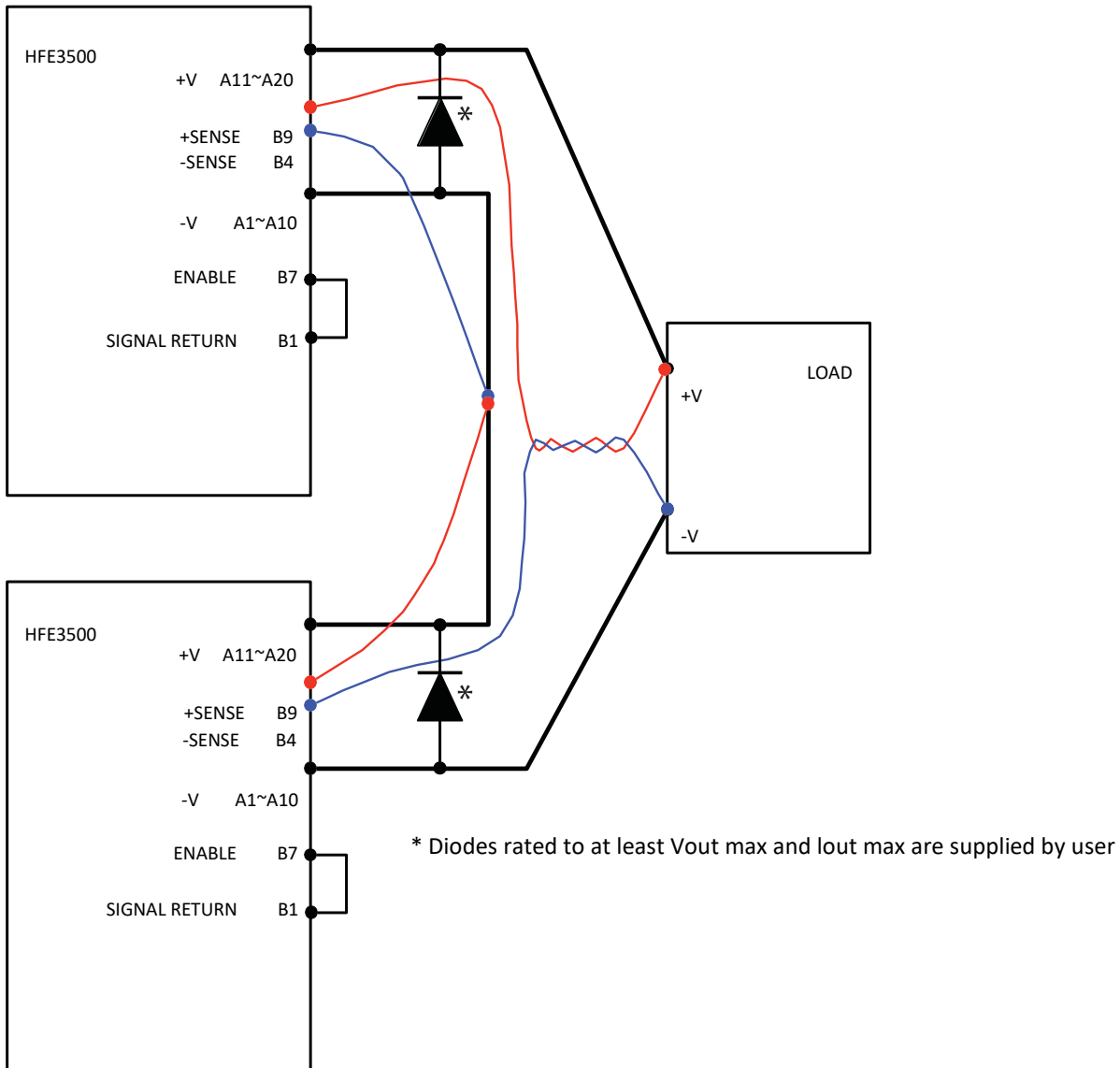

Figure 3–2: Series Connection (Remote Sense Configuration)

CHAPTER 4: PMBUS INTERFACE

4.1 HFE3500 Series I²C Specification

1. FEATURES

1.1	Output voltage measurement
1.2	Output voltage programming
1.3	Hiccup OCP threshold programming
1.4	Output current measurement
1.5	Internal temperature measurement
1.6	Product information
1.7	Status information
1.8	SMBus alert
1.9	Clock frequency: 100KHz and 400kHz supported
1.10	Address lines: 4

The HFE3500 PMBus communications is compliant with PMBus Specification v1.3.1 (with regards to the features which are offered on the HFE3500). This unit can be connected to older revisions of PMBus communication busses. Commands from the previous generation HFE2500 are implemented (except for the output current programming which is replaced with hiccup OCP current threshold programming and has its own separate PMBus command to the output voltage programming that does not require a physical connection between V_REF and I_PROG). Where a standard PMBus command is not supported, the unit will return an error.

2. OUTPUT VOLTAGE MEASUREMENT

		HFE3500-24	HFE3500-48
2.1 Measurement accuracy	-	+/-1% of full scale. Refer to instruction manual	
2.2 Measurement resolution	mV	10	
2.3 Measurement range (Full Scale, Only for Accuracy Calculation)	V	0~30	0~60

3. OUTPUT VOLTAGE PROGRAMMING

		HFE3500-24	HFE3500-48
3.1 Programming accuracy	-	+/-1% of full scale	
3.2 Programming resolution	mV	10	
3.3 Programming range	V	24.0~27.6	48.0~55.2

4. Hiccup OCP Threshold PROGRAMMING

		HFE3500-24	HFE3500-48
4.1 Programming accuracy	-	+/-8% of full scale	
4.2 Programming resolution	-	0.1% of full scale	
4.3 Programming range	-	40~110% of full scale	

5. OUTPUT CURRENT MEASUREMENT

		HFE3500-24	HFE3500-48
5.1 Measurement accuracy (*1)	-	+/-10% of full scale	
5.2 Measurement resolution	mA	100	10
5.3 Measurement range (Full Scale, Only for Accuracy Calculation)	A	0~150	0~75

(*1) Applicable for load above 15% of nominal output current

6. INTERNAL SUPPLY TEMPERATURE MEASUREMENT

6.1 Measurement device accuracy	°C	±3
6.2 Measurement resolution	°C	0.01
6.3 Measurement range	°C	0~130

7. PRODUCT INFORMATION

7.1 Product ID	-	Factory programmed
7.2 Model Name	-	Factory programmed
7.3 Revision	-	Factory programmed
7.4 Serial Number	-	Factory programmed
7.5 Manufacturing location	-	Factory programmed
7.6 Coefficients	-	Factory programmed
7.7 Date of Manufacture	-	Factory programmed
7.8 Nominal Output	-	Factory programmed

8. STATUS INFORMATION

8.1 "FAN FAIL" Signal	-	"1" -FAIL, "0"-OK
8.2 "DC FAIL" Signal	-	"1" -FAIL, "0"-OK
8.3 Output "OVP" Signal	-	"1"- OVP, "0"-OK
8.4 "TEMPERATURE ALARM" signal	-	"1"- ALARM, "0"-OK
8.5 "OTP" Signal	-	"1" -OTP, "0"-OK
8.6 "AC FAIL" Signal	-	"1" -FAIL, "0"-OK
8.7 I ² C ON/OFF control	-	"1" -ON, "0"-OFF

4.1.1 PMBus Interface

The communications bus signals are powered by an external 3.3V power source pulled up with a 1.5kΩ resistor.

4.1.2 HFE3500 Has Power Management Bus Hardware

The PMBUS interface in the HFE3500 includes:

- Monitoring the Output Voltage, Current and Temperature.
- Programming the Output Voltage and Hiccup OCP Output Current Threshold.
- Programming the Maximum allowed output Voltage.
- Programming the Supply On/OFF.
- Reading and Clearing Faults.
- Reading the Manufacturing Related Data (Model Name, Serial No, Manufacturing Date, etc.).
- Restoring all stored user settings at AC On with commands available during operation to:
 - Store user settings.
 - Restore to factory defaults both the user settings and the stored user settings.
 - Restore user settings.

ATTENTION:

If PMBus is used for voltage programming, the reference voltage will not be fixed to 2.5V but can be variable (Reference voltage will be used for voltage programming).

The PMBUS supports:

- 100 and 400 KHz Operation.
- Block Read Protocol.
- Direct Data Format for Monitoring and Programming Functions.
- Support of Packet Error Checking (PEC)
- Compliance with PMBus specification v1.3.1 (with regards to the features which are offered on the product).

4.1.3 Addressing (A3, A2, A1, A0 Inputs)

Four variable address lines allow up to 16 Supplies to be connected on a single bus.

PMBus uses 7 bit addressing.

There is a constant part of address and a variable part of address:

Constant part of the address consists of 3 Most Significant Bits A6, A5, A4 always equals 001.

Variable part of the address consists of 4 Least Significant bits: A3, A2, A1, and A0.

Value of these four bits have to be assigned by hardware connections of 4 pins of the PS connectors.

The Address lines (A3, A2, A1, and A0) are internally pulled up by resistors to +5V.

The address lines can be left open for <1> address or connected to -S for <0> address.

So, available Address Space contains 16 possible addresses: from 0010000 to 0011111.

In case more than one unit is connected to PMBus, each unit must be set to its own unique address.

Duplicate addressing is not allowed.

For example:	First unit - A3(J1.B10), A2(J1.B5), A1(J1.B14), A0(J1.B16) are not connected	– ADDRESS 0011111;
	Second unit - A0(J1.B16) is connected to -SENSE	– ADDRESS 0011110;
	Third unit – A1(J1.B14) is connected to -SENSE	– ADDRESS 0011101;

ATTENTION:

A3, A2, A1, A0 signals and -SENSE are NOT isolated from the Output Terminals.

Hot Plug: When hot plugging a power supply into a live system, the supply takes about 1-2 seconds to configure its address on the bus (based on the analog voltage levels present on the back plane).

4.1.4 Serial Clock

This line is clocked by the Controller which controls the PMBUS. It should be connected to +3.3V (Referenced to "Signal RTN") via a 1.5kΩ pull-up resistor.

4.1.5 Serial Data

This is a Bi-Directional line which must be connected to +3.3V (referenced to Signal RTN) via a 1.5kΩ pull up resistor.

4.1.6 SMB Alert

SMBALERT is used to indicate to the HOST* about any Faults/Error Conditions. This line must be connected to +3.3V (referenced to Signal RTN) via a 1.5kΩ pull up resistor. This Signal is HIGH to indicate that no fault/error is present. If some fault/error occurs, the signal will go LOW. The Host system must poll multiple supplies after receiving SMBALERT to retrieve fault/warning information.

(*) A master is any device that initiates transmission and drives the clock. A master device can be a PC or microcontroller and a slave device here is the power supply.

4.1.7 PMBus Typical Connection

"SIGNAL RETURN" and PMBus signals are isolated from the Output terminals and Senses.

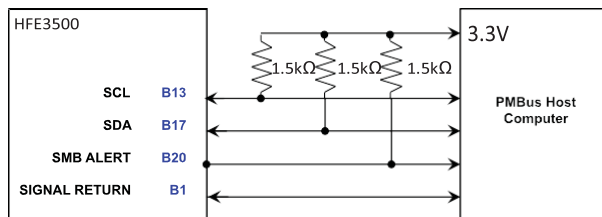

Figure 4–1: PMBus Typical Connection

4.1.8 Packet Error checking

Packet error checking (PEC) is supported by the PMBus interface. The unit works with both PEC and non-PEC without a configuration change since each message:

- The unit identifies whether PEC is active by comparing the number of bytes of a write message against the number expected for the received command.
- The unit always sends a PEC byte on the end of read messages.

If the host/master is using PEC, each bus transaction requires a Packet Error Code (PEC) calculation by both the transmitter and receiver within each packet. The PEC uses 8-bit CRC of each read or write bus transaction to calculate a PEC. The PEC may be calculated in any way that conforms to CRC-8 represented by polynomial $C(x) = x^8 + x^2 + x^1 + 1$, and must be calculated in the order of the bits as received. In the event of the PEC indicating a corrupted transmission, the unit takes the following actions, per the PMBus Specification:

- Does not respond to or act upon the command
- Sets the Command Error bit in the STATUS REGISTER
- Notifies the master of the presence of a fault condition by pulling the SMBALERT line low.

4.2 PMBus Command Set

The interval between two consecutive commands to the power supply should be at least 25ms to ensure proper monitoring functionality.

4.2.1 Read Status

This Command is used to read the status of the Power Supply. The Status information is stored in a special register called the "STATUS REGISTER". The PMBUS reads 8 different types of Faults and Warnings.

Command Used	Type	#Data bytes
D0h	Read Byte	1

Fault is indicated by "1". No fault is indicated by "0".

For Example: If DC Fail occurs, READ_STATUS will return 01h. SMBALERT will go "LOW".
If AC Fail occurs, READ_STATUS will return 11h. SMBALERT will go "LOW".

Faults	Type	Bit No in Status Register	Meaning	Main Output Behavior
DC Fail	FAULT	0	Output Voltage < 85~95% of Set Vout	Output OFF/Output Low
Over Temperature Protection	FAULT	1	Internal temperature higher than safe limit	Output OFF
Over Temperature Alarm	WARNING	2	Internal temperature ~ 10°C below safe limit	Output ON
Fan Fail	FAULT	3	One or both Fans are not working	Output OFF
AC Fail	FAULT	4	Input Voltage <85Vac	Output ON before then collapsing
Over Voltage Protection	FAULT	5	Output Voltage > 1.15xVset	Output OFF
Programmed Voltage more than allowed	WARNING	6	Programmed Voltage more than Max Allowed Voltage (*1)	Output ON
Command Error	WARNING	7	Command not understood by Power Supply (*2)	Output ON

(*1) If Max Allowed Voltage is set to 48V and Programmed Voltage is set to 50V, Output will be programmed to 48V, Bit No 6 will be "1", and SMBALERT will become "LOW".

(*2) If any Command sent is not understood by the Supply, bit no 7 will be "1" and SMBALERT will become "LOW".

4.2.2 Clear Faults

This command is used to clear the "STATUS REGISTER" after any fault occurs.

If the CLEAR_FAULTS command is not sent after any fault, the "STATUS REGISTER" will not be cleared.

SMBALERT signal will remain "LOW" until "CLEAR_FAULTS" command is sent.

If a Fault or Warning is still present after "CLEAR_FAULTS" is sent, "STATUS REGISTER" will be updated and the SMBALERT signal will be "LOW" again.

Command Code	Type	#Data bytes
03h	Send Byte	0

4.2.3 Operation (ON/OFF)

Command Code	Type	#Data bytes
01h	R/W Byte	00h=OFF
01h	R/W Byte	80h=ON

If the Power Supply is turned OFF with the "OPERATION OFF" command, the Supply can be turned ON with the "OPERATION ON" command only. Inhibit and Enable signals are disabled.

4.2.4 Commands to Read Inventory Details

Command Name	Command Code	Type	#Data Bytes
PMBUS_REVISION	98h	Read Byte	1
MFR_ID	99h	Read Block	16
MFR_MODEL	9Ah	Read Block	16
MFR_OUTPUT	D1h	Read Block	16
MFR_REVISION	9Bh	Read Block	16
MFR_LOCATION	9Ch	Read Block	16
MFR_DATE	9Dh	Read Block	16
MFR_SERIAL	9Eh	Read Block	20

All details except for <PMBUS_REVISION> are stored in ASCII format.

4.2.5 Restore User Settings to Factory Defaults (RESTORE_DEFAULT_ALL)

Return all user adjustable settings to the values that were set at the factory, and set all the stored user settings to these values so that the unit starts up with the factory default settings.

Command Code	Type	#Data bytes
12h	Send Byte	0

Factory default settings:

Commands	Command Code	Default Value
ON/OFF	01h	80h = ON (Whether the unit turns on is subsequently determined by the non-PMBus inputs)
VOUT_COMMAND	21h	00h = Disabled (output voltage is always determined by input to analogue voltage programming input, Nominal output voltage is produced in this condition if V_REF is connected to Voltage Programming analogue input)
VOUT_MAX	24h	00h = Feature Disabled
MFR_ILIMIT_COMMAND	E3h	00h = PMBus Hiccup OCP Current Threshold Override Disabled (so OCP current threshold is set by the hiccup OCP current programming analogue input)

4.2.6 Store Present User Settings (STORE_USER_ALL)

Stores the existing user settings to be loaded each time AC is applied to the unit, and these settings are also loaded when the RESTORE_USER_ALL command is given.

Command Code	Type	#Data bytes
15h	Send Byte	0

4.2.7 Restore Saved User Settings (RESTORE_USER_ALL)

Loads the saved user settings.

Command Code	Type	#Data bytes
16h	Send Byte	0

4.3 Programming and Monitoring Functions

For Monitoring and Programming functions use the following equation. This is the direct data format.

$$Y = (mX + b) * 10^R, \quad X = \frac{(Y * 10^{-R} - b)}{m}$$

Where **Y** - digital value sent or received from the supply.
X is the normal value (V, A, °C)
m, b, R - coefficients that are explained in Table 4-1.

Voltage (V)	Physical value	Physical Unit	Min. Value	Max. Value	m	b	R
48	Voltage Programming	V	48.0	55.2	1	0	2
	Voltage monitoring	V	0	60	1	0	2
	Current monitoring	A	0	75	1	0	2
	Temperature monitoring	°C	0	130	1	0	2
24	Voltage Programming	V	24.0	27.6	1	0	2
	Voltage monitoring	V	0	30	1	0	2
	Current monitoring	A	0	150	1	0	1
	Temperature monitoring	°C	0	130	1	0	2
24, 48	Hiccup OCP Current Threshold Programming	%	40	110	1	0	1

Table 4-1: Coefficients Table

4.3.1 Monitoring Output Voltage (READ_VOUT)

The accuracy of the voltage reading is +/-1%
 The output voltage is read from the remote sense inputs.
 The read back Output Voltage can be calculated using the “Direct data Format”.
 Refer to Table 4-1 for the Coefficients for calculating the Output Voltage.

Command Code	Type	#Data Bytes
8Bh	Read Word	2

Example: Power Supply HFE3500-48;
 Hex read back = 129Ah;
 Converted to Decimal = 4762;
 Using the required coefficients the Output Voltage (on the remote sense) 4762/100 = 47.62V.

Supply (*1)	Full Scale (*1)
HFE3500-24	30V
HFE3500-48	60V

4.3.2 Monitoring Output Current (READ_IOUT)

The accuracy of the current reading is +/-10%
 The read back output current can be calculated using the “Direct data Format”.
 Refer to Table 4-1 for the Coefficients for calculating the Output Current.

Command Used	Type	#Data Bytes
8Ch	Read Word	2

Example: Power Supply HFE3500-48;
 Hex read back = 13D1h;
 Converted to Decimal = 5073;
 Using the required coefficients the output current = 5073/100 = 50.73A;

Supply (*1)	Full Scale (*1)
HFE3500-24	150A
HFE3500-48	75A

4.3.3 Monitoring Supply Temperature (READ_TEMPERATURE_1)

The accuracy of the Temperature reading is +/-3°C

The read back supply temperature can be calculated using the “Direct data Format”.

Please refer to Table 4-1 for the Coefficients for calculating the Supply Temperature.

Command Used	Type	#Data Bytes
8Dh	Read Word	2

Example: Hex read back = 122Dh;
 Converted to Decimal = 4653;
 Using the required coefficients the Supply Internal Temperature = 4653/100 = 46.53°C.

4.3.4 Programming Output Voltage (VOUT_COMMAND)

The accuracy of the Output Voltage Programming is +/-1%.

This feature adjusts the output voltage via the V_REF output.

The V_REF output needs to be connected to the Voltage Programming analogue input to allow the PMBus to program the output voltage of the unit (and the output voltage of any other units connected in parallel).

The output Voltage is programmed using the “Direct data Format”.

Please refer to Table 4-1 for the Coefficients to be used for calculating the Voltage Programming.

Having this command set to 0 makes the V_REF setting 2.5V, which sets the output voltage of the power supply to nominal if the V_REF is connected to the analogue Output Voltage Programming input.

Command Used	Type	#Data Bytes
21h	R/W Word	2

Example: Power Supply HFE3500-24;
 To program the Output Voltage to 24V, send (1x24+0)x100 = 2400 (DEC);
 Hex = 960h

Supply (*1)	Full Scale (*1)
HFE3500-24	30V
HFE3500-48	60V

4.3.5 Programmable Maximum Output Voltage (VOUT_MAX)

The Maximum Output Voltage can be programmed using the “Direct data Format”.

Programming to 0 disables this feature.

Please refer to Table 4-1 for the Coefficients to be used for calculating the Voltage Programming.

Command Used	Type	#Data Bytes
24h	R/W Word	2

Example: Power Supply HFE3500-24;
 To program the maximum programmable output voltage to 26V.
 Send 26x100 = 2600 (DEC)

4.3.6 Programming Hiccup OCP Current Threshold (MFR_ILIMIT_COMMAND)

Overrides analogue HICCUP_OCP_I_PROG input.

Have this command set at 0 to disable the override to allow the OCP threshold to be set by the analogue input.

The accuracy of the OCP Threshold Programming is +/-8%.

The OCP output current threshold is programmed via the PMBus using the “Direct data Format”.

Please refer to Table 4-1 for the Coefficients to be used for calculating the OCP threshold programming.

Command Used	Type	#Data Bytes
E3h	R/W Word	2
Command Used	Type	#Data Bytes
E3h	R/W Word	2

Example: Power Supply HFE3500-48;
 To program the unit to have its hiccup OCP current threshold at 80% of rated output current, send
 80x10 = 800 (DEC)