

TDK-Lambda

NV-350

+

NV-700

AC/DC Power Supply Series

APPLICATION NOTE

| | |
|--|-----------|
| 1. INPUT | 3 |
| AC INPUT LINE REQUIREMENTS..... | 3 |
| 2. DC OUTPUT | 3 |
| OUTPUT VOLTAGES..... | 3 |
| REMOTE SENSE..... | 3 |
| NO LOAD OPERATION | 5 |
| SERIES/PARALLEL CONNECTION | 5 |
| OUTPUT CHARACTERISTICS..... | 6 |
| • Ripple/Noise | 6 |
| POWER SUPPLY TIMING..... | 7 |
| PRIMARY OPTION SIGNALS | 8 |
| STANDBY SUPPLY (+V Standby Pin 1, 0V Standby Pin 2)..... | 8 |
| EN/ES Logic 1 (Primary Option Pin 3) | 8 |
| IN/IS Logic 1 (Primary Option Pin 3) | 8 |
| EN/ES Logic 0 (Primary Option Pin 4) | 9 |
| IN/IS Logic 0 (Primary Option Pin 4) | 9 |
| GLOBAL MODULE GOOD (Primary Option Pins 5 & 6)..... | 9 |
| AC GOOD SIGNAL (Primary Option Pins 7 & 8) | 10 |
| SECONDARY SIGNALS | 10 |
| CH1 & CH2 OUTPUT GOOD (Module Pins 6 & 2) | 10 |
| MODULE INHIBIT (Module Pin 4)..... | 11 |
| OVERSHOOT AT TURN ON/OFF | 11 |
| OUTPUT PROTECTION | 12 |
| COOLING REQUIREMENTS | 12 |
| TEMPERATURE DERATING | 13 |
| ELECTROMAGNETIC COMPATIBILITY | 14 |
| Installation for optimum EMC performance | 15 |
| ESD Protection | 15 |
| RELIABILITY | 16 |
| CONNECTION | 17 |
| Input | 17 |
| Output | 17 |
| Signals | 17 |
| Pin Definition - Primary Option | 17 |
| Pin Definition – Secondary Signals | 17 |
| MOUNTING | 17 |

1. INPUT

AC INPUT LINE REQUIREMENTS

See datasheet for specification of input line requirements (including Input voltage range, Input frequency, Input harmonics, Input current and leakage current)

The power supply will automatically recover from AC power loss and shall be capable of startup under full loading at 90VAC.

Repetitive ON/OFF cycling of the AC input voltage shall not damage the power supply or cause the input fuse to blow.

- Input Fuse
Not user serviceable. (6.3A in NV-350 and 16A in NV-700), fast acting, high breaking capacity, ceramic fuse.
- Input Undervoltage
The power supply is protected against the application of an input voltage below the minimum specified so that it shall not cause damage to the power supply.

2. DC OUTPUT

OUTPUT VOLTAGES

All output channels have isolated 0V (except for the two outputs of the DA module that have a common 0V). See the datasheet for full specifications of the output, including adjustment range, output current, remote-sensing capability, regulation, ripple & noise and setting accuracy.

The auxiliary supply is an independent, floating, isolated output that is present whilst the ac input is present, irrespective of the state of the other channels (or remote on/off).

REMOTE SENSE

Remote sensing is provided to compensate for voltage drops in the power connections to the load. Remote sense is available for Output 1 on all modules. Up to 0.5V total line drop can be compensated. The remote sense lines may be connected as follows:-

- If remote sense is not required, simply do not connect either '+sense' or '-sense'
- If remote sense is required, connect '-sense' and '+sense' to the corresponding point at the load (see Figure 1 for details)
- Note – do not connect remote sense across an output fuse
- Care should be taken to ensure that remote sense is connected in the correct polarity and is disconnected from the load before the power connections are removed.

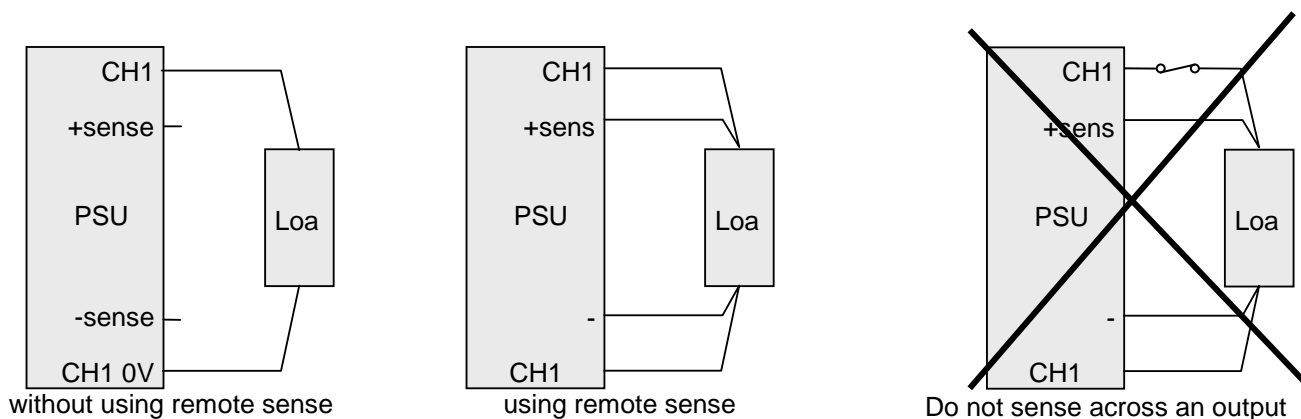

Figure 1: How to connect power supply to load

EFFICIENCY

The efficiency of the PSU is likely to vary depending on its exact configuration. Figure 2 shows a typical efficiency v output power characteristic of a PSU configured with three 12V single output modules.

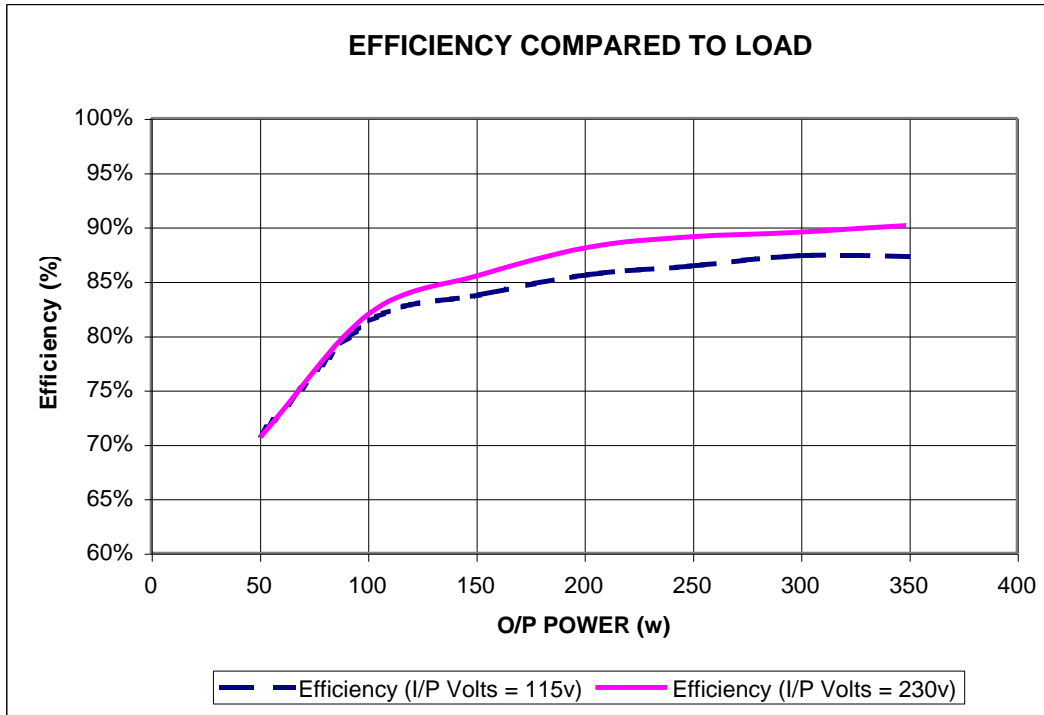

Figure 2. NV350 Efficiency Chart

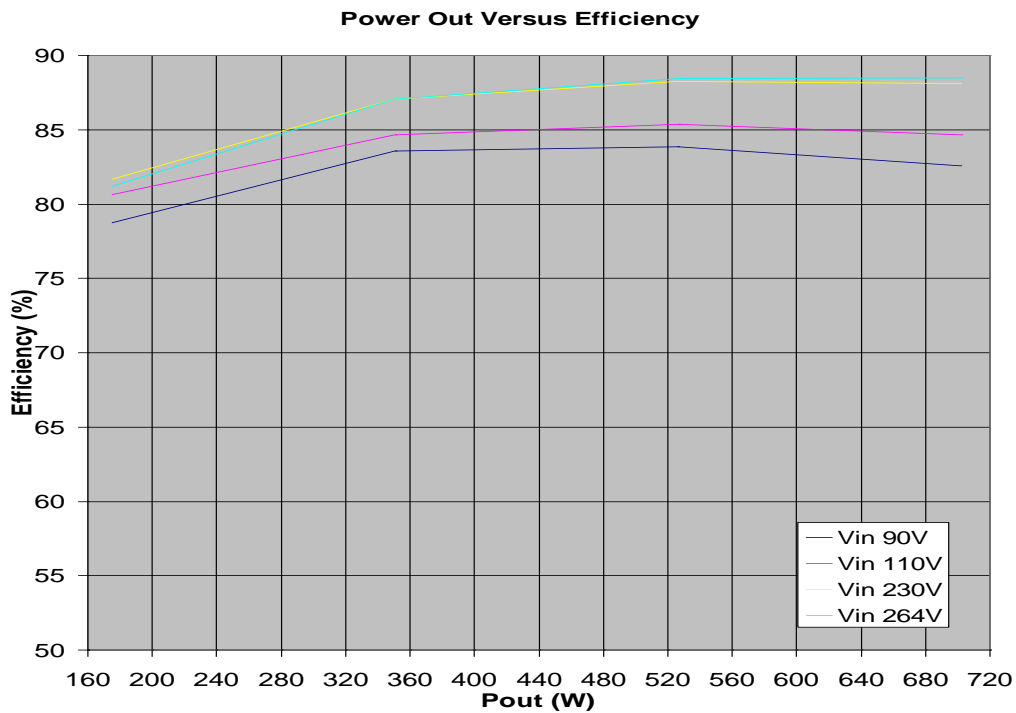

Figure 3. NV700 Efficiency Chart
With 1x3.3V output, 1x5V output, 1x12V output and 1x24V output

NO LOAD OPERATION

No minimum load is required for the power supply to operate within specification.

SERIES/PARALLEL CONNECTION

It is possible to connect multiple NV-350/NV-700 (or multiple outputs from the same NV-350/NV-700) in series. Do not exceed 160V for the total voltage of outputs connected in series.

The outputs connected in series are non-SELV (Safety Extra Low Voltage) if the total output voltage + 30% of the highest maximum rated output voltage exceeds 60V (the 30% margin allows for a single fault in any one individual channel).

Outputs must not be connected in parallel.

OUTPUT CHARACTERISTICS

- Ripple/Noise

Ripple and noise is defined as periodic or random signals over a frequency range of 10Hz to 20MHz. Measurements are to be made according to EIAJ methods. This is done with a 20MHz bandwidth oscilloscope with measurements taken at the end of a 150mm length of a twisted pair of cables, terminated with a 0.1 μ F ceramic capacitor in parallel with a 120 μ F electrolytic capacitor as shown in Figure 4. The earth wire of the oscilloscope probe should be as short as possible, winding a link wire around the earth collar of the probe is the preferred method.

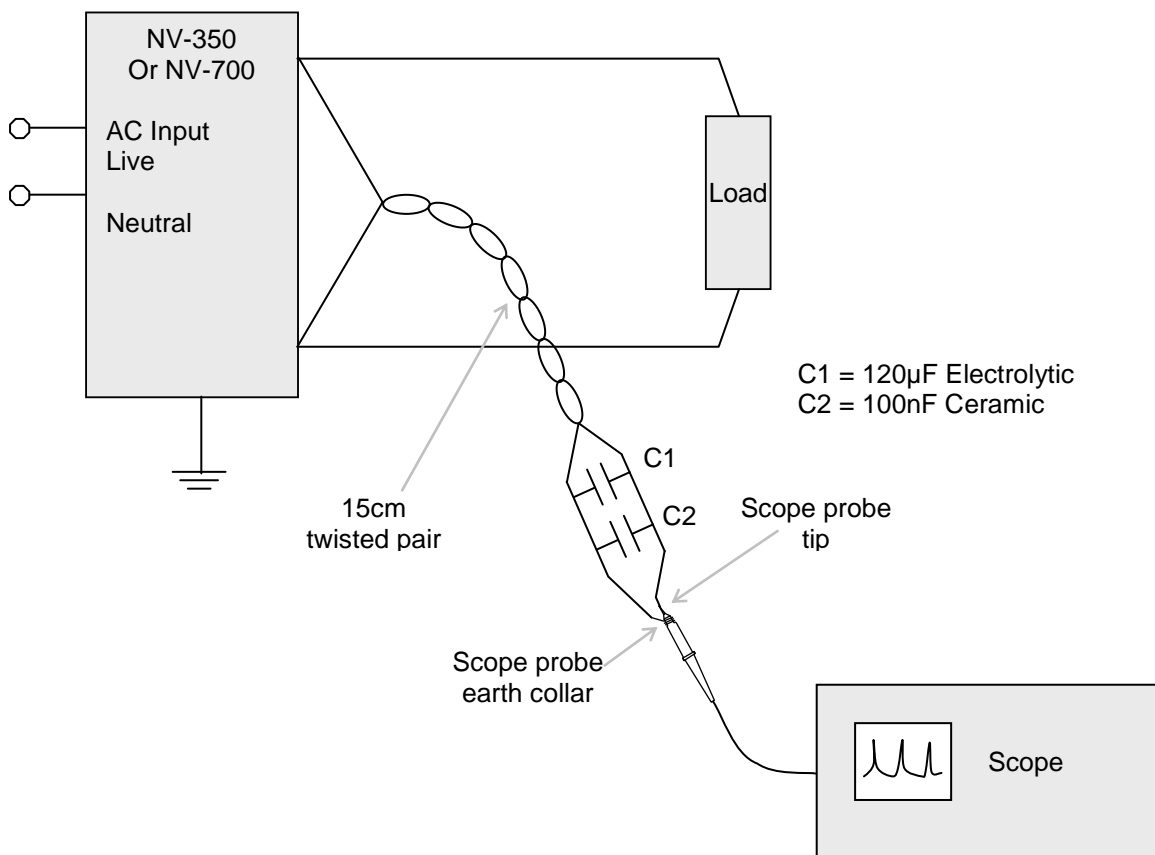
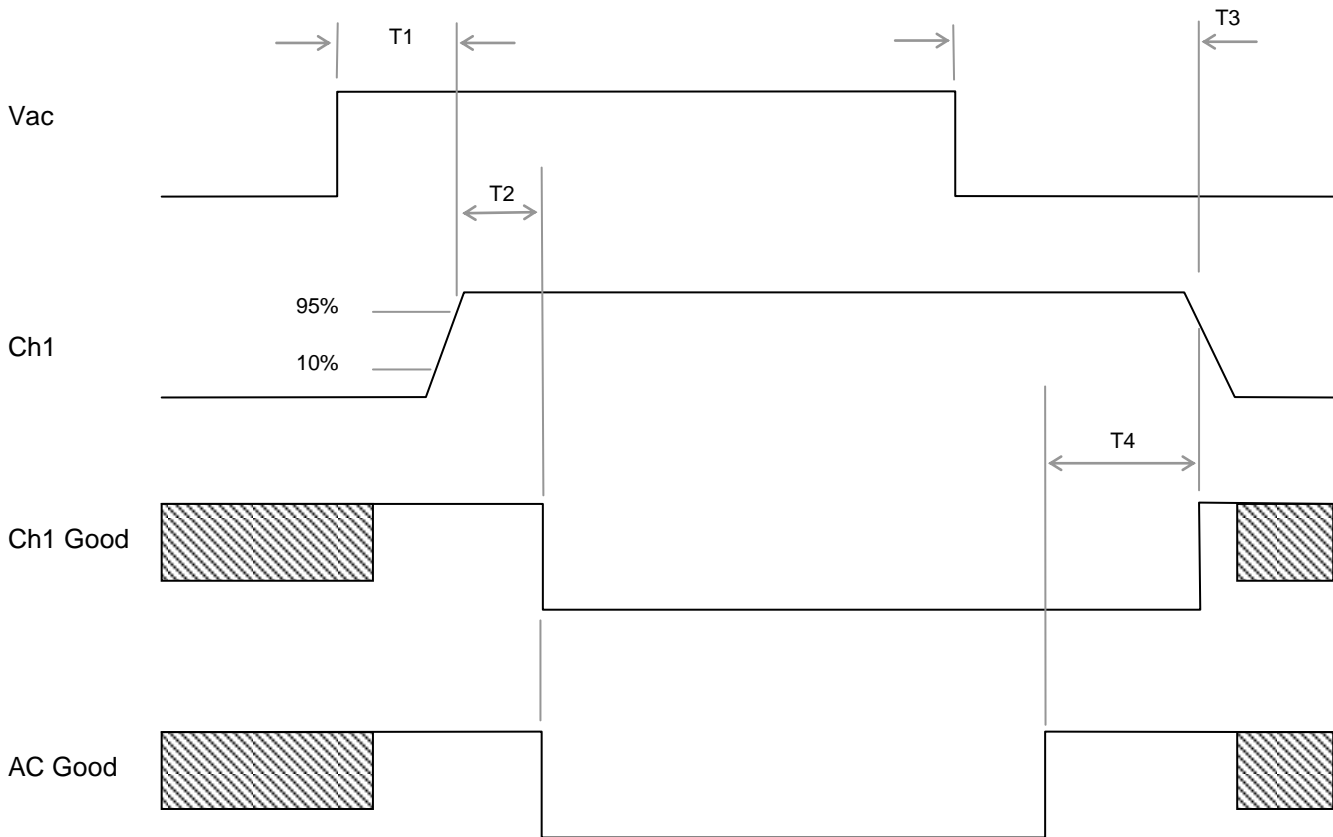

Figure 4: RIPPLE AND NOISE MEASUREMENT METHOD

POWER SUPPLY TIMING



| | min | Typical | max | Description |
|----|------|---------|------|---------------------------|
| T1 | | | 1.5s | Turn on time |
| T2 | | 200ms | | Output good hold off time |
| T3 | 16ms | | | Hold up time |
| T4 | 5ms | | | AC good warning time |

Figure 5: Output timing diagram

PRIMARY OPTION SIGNALS

STANDBY SUPPLY (+V Standby Pin 1, 0V Standby Pin 2)

5V / 2A (2.5A Peak) or 12V / 1A (1.2A peak)

Supply is isolated from all module outputs and is not inhibited or enabled by any signal/control.

EN/ES Logic 1 (Primary Option Pin 3)

TTL High level relative to 0V Standby enables the PSU fitted (including fan) with EN or ES type primary option. This signal does not enable the standby supply. If using this input then Pin 4 must be left open circuit.

| | |
|---------------------------------------|-----------------------------------|
| Signal Type | TTL Logic. Relative to 0V Standby |
| Logic | Active High (High to enable) |
| Minimum Current Required | 0.5mA |
| Maximum voltage (Pin 3 to Standby 0V) | 5V |

IN/IS Logic 1 (Primary Option Pin 3)

TTL High level relative to 0V Standby inhibits the PSU (including fan) fitted with IN or IS type primary option. This signal does not inhibit the standby supply. If using this input then Pin 4 must be left open circuit.

| | |
|---------------------------------------|-----------------------------------|
| Signal Type | TTL Logic. Relative to 0V Standby |
| Logic | Active High (High to inhibit) |
| Minimum Current Required | 0.5mA |
| Maximum voltage (Pin 3 to Standby 0V) | 5V |

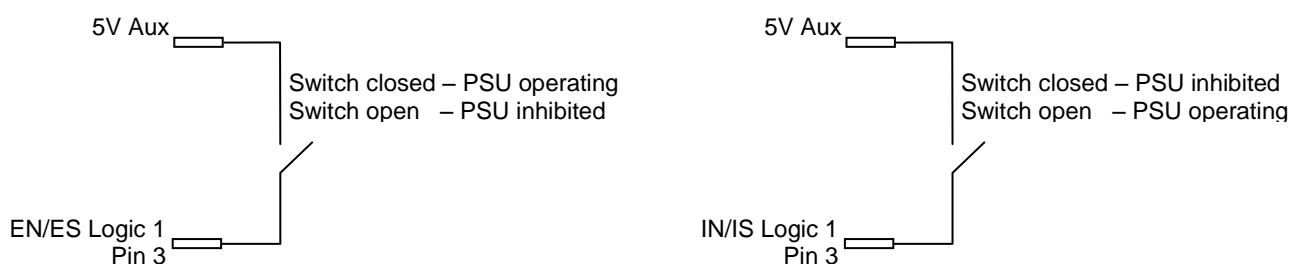

Figure 6: Example use of 'EN/ES & IN/IS Logic 1'

EN/ES Logic 0 (Primary Option Pin 4)

TTL Low level relative to 0V Standby enables the PSU (including fan) fitted with EN or ES type primary option. This signal does not enable the standby supply. If using this input then Pin 3 must be left open circuit.

| | |
|---------------------------------------|-----------------------------------|
| Signal Type | TTL Logic. Relative to 0V Standby |
| Logic | Active Low (Low to Enable) |
| Minimum Current to sink | 0.5mA |
| Maximum voltage (Pin 4 to Standby 0V) | 5V |

IN/IS Logic 0 (Primary Option Pin 4)

TTL Low level relative to 0V Standby inhibits the PSU (including fan) fitted with IN or IS type primary option. This signal does not inhibit the standby supply. If using this input then Pin 3 must be left open circuit.

| | |
|---------------------------------------|-----------------------------------|
| Signal Type | TTL Logic. Relative to 0V Standby |
| Logic | Active Low (Low to Inhibit) |
| Minimum Current to sink | 0.5mA |
| Maximum voltage (Pin 4 to Standby 0V) | 5V |

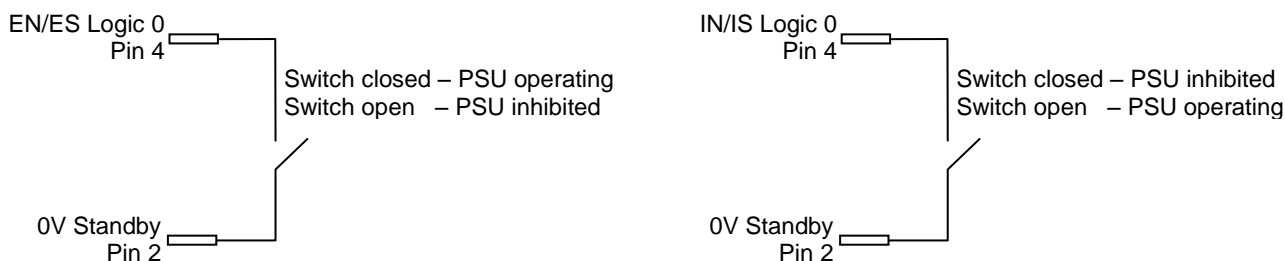

Figure 7: Example use of 'EN/ES & IN/IS Logic 0'

GLOBAL MODULE GOOD (Primary Option Pins 5 & 6)

(Available on EN/IN type Primary options only)

This is an un-committed opto-coupler which turns on 200mS (typically) after all outputs are within 95% of nominal. The signal turns off if any output drops below 95% of nominal. The signal also turns off if an AC Fail condition is detected, in which case it provides 5mS (min) warning before any output is likely to drop below 95% of nominal.

Do not connect on ES and IS type primary options.

| | |
|--------------------------------------|---------------------------|
| Signal Type | Uncommitted opto-coupler. |
| Maximum Current | 5mA |
| Maximum voltage (collector to 0V) | 30V |
| Logic low (when signal is turned on) | <0.4V when sinking 5mA |

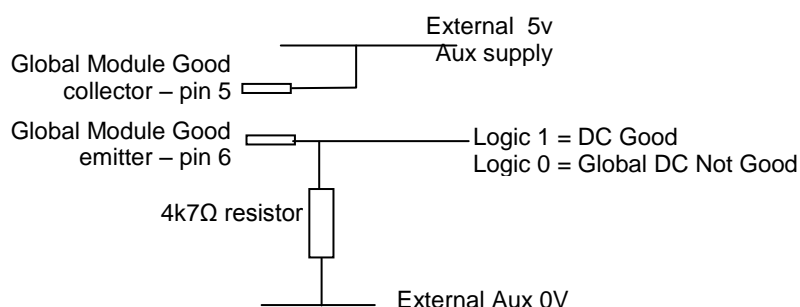

Figure 8: Example use of 'Global Module Good'

AC GOOD SIGNAL (Primary Option Pins 7 & 8)

The AC Good signal is an uncommitted opto-coupler which turns on 5ms (typically) after ac is good and off 5ms (typically) before any channel falls below 95% of nominal. It is delayed after startup to ensure that sufficient primary side energy is stored by the power supply for continuous power operation within the specified hold-up time. When the input power is removed the AC Good Signal will go to an open circuit state. The specification for the Power Good Signal is shown below

| | |
|--------------------------------------|---------------------------|
| Signal Type | Uncommitted opto-coupler. |
| Maximum Current | 5mA |
| Maximum voltage (collector to 0V) | 30V |
| Logic low (when signal is turned on) | <0.4V when sinking 5mA |

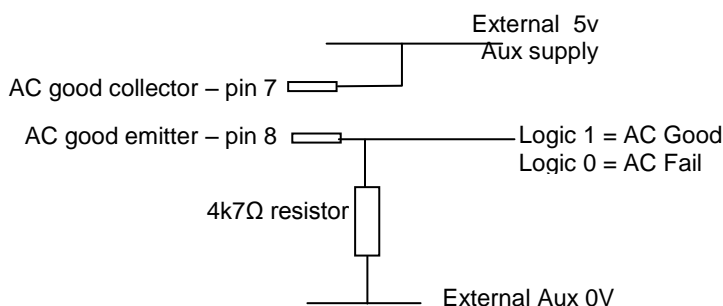

Figure 9: Example use of 'AC Good'

SECONDARY SIGNALS

CH1 & CH2 OUTPUT GOOD (Module Pins 6 & 2)

The Output Good signal is an open collector signal output which is turned on to indicate that output is operating within its regulation limits. When the Output falls to below 85% of nominal, the Output Good Signal will go to an open circuit state. The specifications for the Output Good Signal are contained below

| | |
|--------------------------------------|--|
| Signal Type | Open collector output. Emitter connected to 0V of appropriate channel. |
| Maximum Current | 5mA |
| Maximum voltage (collector to 0V) | 30V |
| Logic low (when signal is turned on) | <0.4V when sinking 5mA |



Figure 10: Example use of 'Output Good'

MODULE INHIBIT (Module Pin 4)

TTL Logic high (relative to 0V of Channel 1) inhibits the output (both outputs for dual modules) of the module.

| | |
|-------------------------------|--------------------------------|
| Signal Type | TTL Logic. Relative to CH1 0V. |
| Minimum Current to source | 5mA |
| Maximum voltage (Pin 4 to 0V) | 5V |

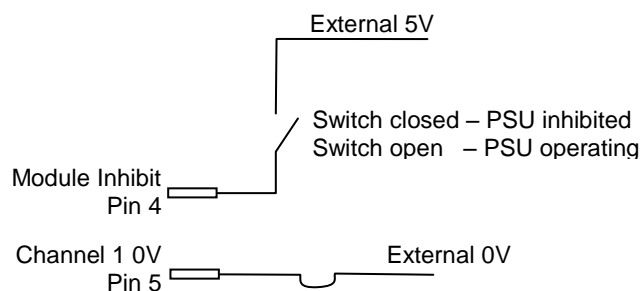

Figure 11: Example use of 'Module Inhibit'

CHANNEL 2 ON/OFF (Module Pin 3)

(Only for dual output modules. Do not connect on single output modules)

TTL Logic low (relative to 0V of Channel 2) inhibits output 2 of the module.

| | |
|-------------------------------|--------------------------------|
| Signal Type | TTL Logic. Relative to CH1 0V. |
| Minimum Current to sink | 5mA |
| Maximum voltage (Pin 3 to 0V) | 5V |

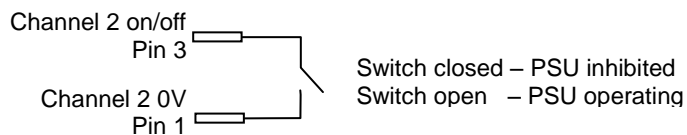

Figure 12: Example use of 'Channel 2 on/off'

OVERSHOOT AT TURN ON/OFF

The output voltage overshoot upon the application or removal of the input mains voltage shall be less than 10% above the nominal voltage. No voltage of opposite polarity shall be present on any output during turn on or turn off.

OUTPUT PROTECTION

Over temperature protection

If the NV-350/NV-700 is operated without adequate cooling, it will cause an over temperature condition and the PSU will shut down. To restart the PSU, remove the ac supply allow the unit to cool down and then reapply the ac supply.

Over voltage protection

An overvoltage on any of the output channels will cause that module to shutdown. To restart the module, remove the ac supply for 2 seconds and then reapply.

Short-Circuit Protection

A short circuit is defined as an impedance of $<0.06\Omega$ placed between the DC return and any output. A short circuit will cause no damage to the power supply and will cause it to shutdown. After removal of the short circuit, the PSU will resume normal operation.

Overcurrent Protection

Overload currents applied to each output will cause the output to trip without damaging the module.

COOLING REQUIREMENTS

For full details of the cooling requirements, please refer to the NV700 Handbook and NV350 Handbook documents available on our website.

Natural Convection

The power supply is not designed to operate without forced air cooling.

TEMPERATURE DERATING

NV-350/NV-700 achieves full power output up to 50°C ambient temperature. Above this temperature, the total output power (and individual output currents) must be derated by 2.5%/°C up to 70°C. See diagram below.

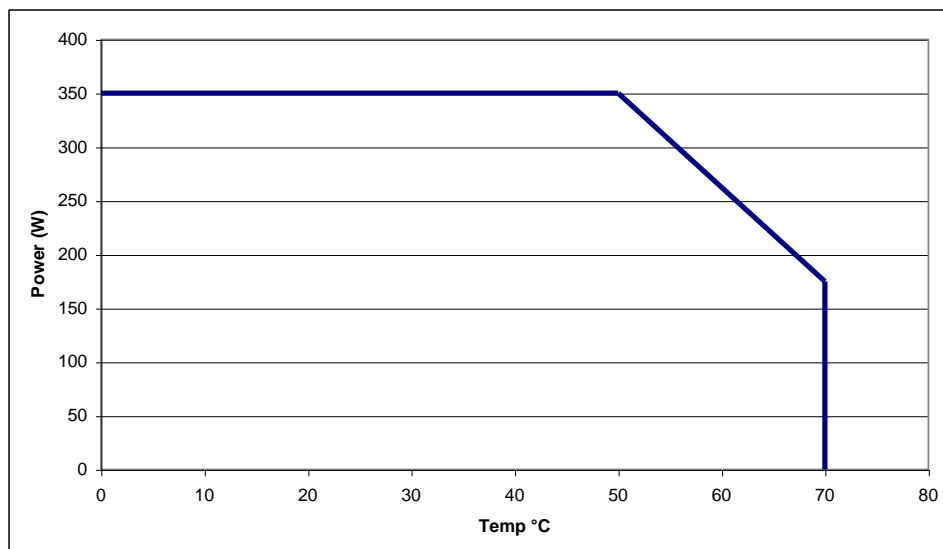

Figure 13: NV-350 Thermal Derating

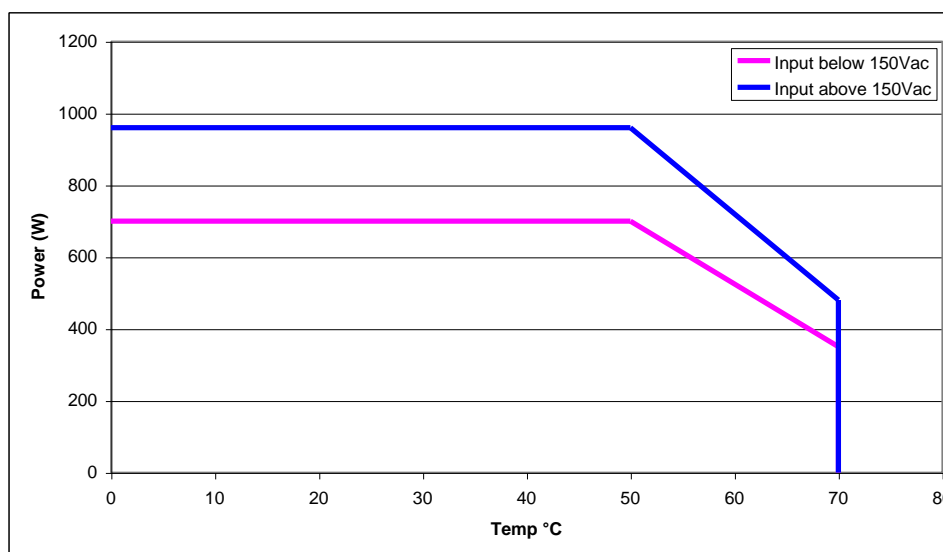

Figure 14: NV-700 Thermal Derating

ELECTROMAGNETIC COMPATIBILITY

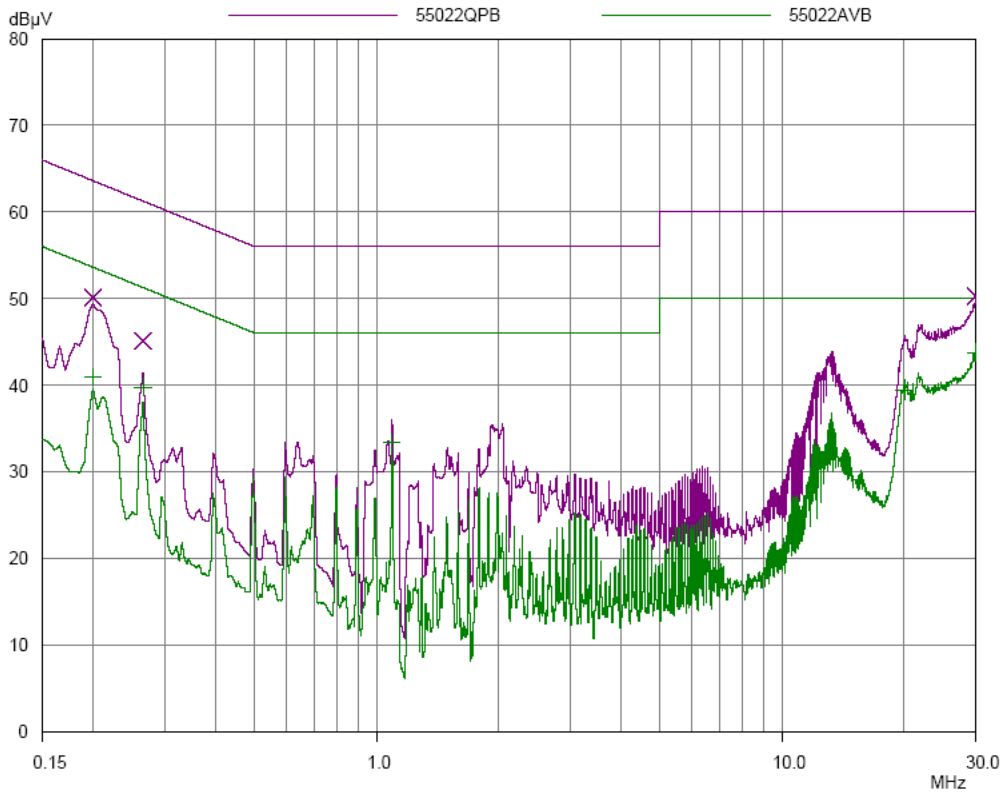

Figure 15: Sample plot of NV350
 Measured at 230V input, 3V3B@35A; 24B@4A; 3V3/12DB@15/4A

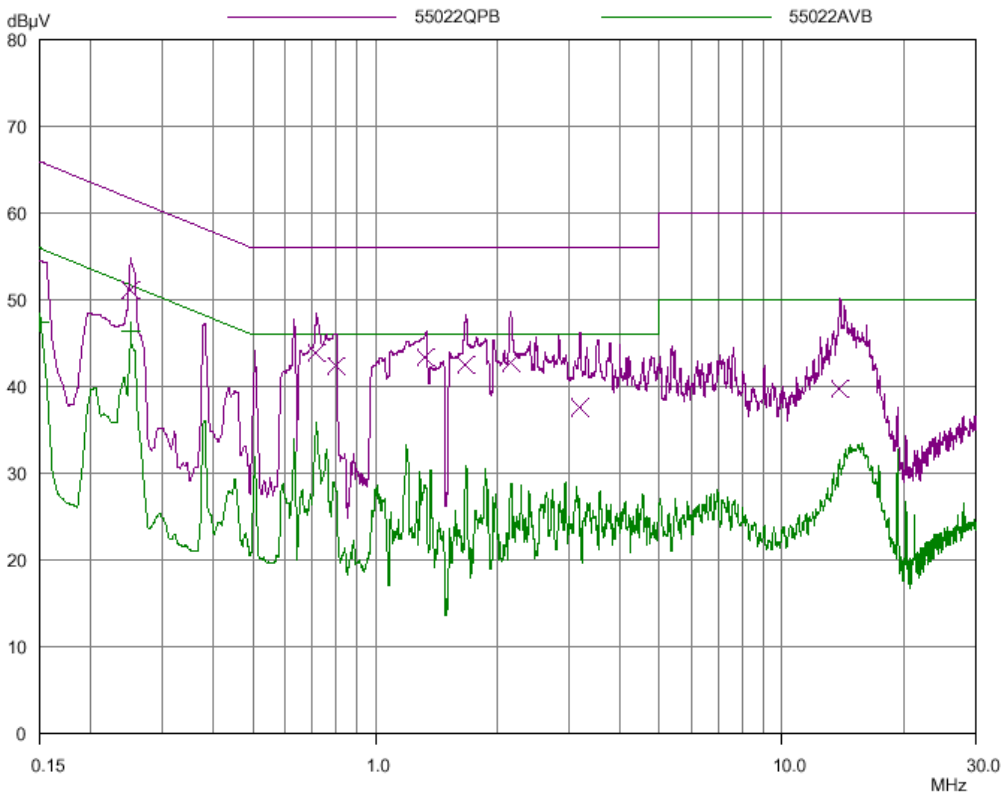

Figure 16: Sample plot of NV700
 Measured at 230V input

Installation for optimum EMC performance

Mounting

All equipment should be mounted inside an earthed metal box.

If this is not possible then use an earthed metal plane to mount the power supply and load.

Cables

All cables (both ac input and dc output) should be run as close as possible to the earthed metal box/plane.

AC input cable should be twisted group laid as flat to the earthed metal box/plane as possible.

All output cables should be routed as far away from input cables as possible.

If the input and output cables must be run close to each other then screen one or other (or ideally both).

The positive and negative supply cables should be twisted together.

The remote sense wires (if used) should be twisted together and run alongside their related supply cables.

All cable run loops should be kept as small as possible (this should be implemented in PCB design also).

Connecting between boxes

If cables must be connected between equipment boxes then at the closest possible point to the port where the cables exit the 1st enclosure connect 100nF decoupling Y caps (between the output and earth). Note that these capacitors must be rated at the working voltage. Ideally these capacitors should be between all signal cables which have to connect between boxes although this may not be practical if fast switching [digital] signals are involved (if this is the case then smaller value Y capacitors should be used).

Earth star point

If the power supply is supplied without an IEC inlet then where the ac supply enters the equipment, this should be taken to a 'star point' chassis mounted earth point as close as possible to the ac inlet. All other earth points should be taken back to this point only.

If the power supply is supplied fitted with an IEC inlet then a 'star point' should be created as near as possible to the mounting screw closest to the inlet side of the power supply.

(Note compliance with EN609050 practices that require own star point washer and nut).

ESD Protection

Where signal or control ports are connected to a user accessible panel (for example PSU inhibit to a switch, module good to an indicator circuit, etc), these ports must be protected from electrostatic discharges. This can be done by selecting suitable panel controls or by fitting ESD suppression devices to the connections on the panel

RELIABILITY

Calculated using Telcordia Issue 1, Case 3

Operating continuously, Ground Benign / Ground Controlled Environment.

FPMH (Failures per million hours)

| Temperature | 0°C | 30°C | 40°C | 50°C | 60°C | 70°C |
|----------------|-------|-------|-------|-------|--------|--------|
| 350W Converter | 0.312 | 0.763 | 1.035 | 1.416 | 1.959 | 2.742 |
| 700W Converter | 0.309 | 0.787 | 1.090 | 1.522 | 2.146 | 3.050 |
| B Module | 0.254 | 0.614 | 0.847 | 1.192 | 1.717 | 2.519 |
| FEP Module | 0.402 | 0.831 | 1.109 | 1.526 | 2.167 | 3.166 |
| C Module | 0.256 | 0.600 | 0.823 | 1.154 | 1.658 | 2.440 |
| DB Module | 0.441 | 1.054 | 1.443 | 2.014 | 2.870 | 4.178 |
| Primary Option | 0.076 | 0.254 | 0.405 | 0.664 | 1.106 | 1.880 |
| DA Module | 0.136 | 0.365 | 0.531 | 0.790 | 1.197 | 1.837 |
| NV-350 Fan | 2.396 | 1.941 | 3.067 | 4.845 | 7.656 | 12.096 |
| NV-700 Fans | 4.792 | 3.882 | 6.133 | 9.691 | 15.311 | 24.192 |

To calculate MTBF, sum the FPMH for all component parts at the required temperature. This gives total failures per million hours (FPMH). Convert this to MTBF by dividing 1000000 by the FPMH.

For example:-

Require the MTBF for NV3SSS 5B 12/12DB at 30°C

| | |
|----------------|-------|
| 350W Converter | 0.763 |
| B module | 0.614 |
| DB module | 1.054 |
| Fan | 1.941 |

Total FPMH 4.372

Therefore MTBF = $1000000 / 4.372 = 228728$ hours (228k hours)

Require the MTBF for NV7CSSES5V 12C at 50°C

| | |
|----------------|-------|
| 700W Converter | 1.522 |
| Primary Option | 0.664 |
| C module | 1.154 |

Total FPMH 3.340

Therefore MTBF = $1000000 / 3.340 = 299401$ hours (299k hours)

CONNECTION

Input

Input is via IEC320 connector (if specified) or 3 x 6-32 screws with 8.25mm spacing between screw head centres. The screw head diameter is 6.6mm. Maximum Torque setting is 0.8Nm.

Output

The screws used for single output modules and channel 1 of dual channel modules are 2 x M4. Maximum torque setting is 1.3Nm.

The screws used for Channel 2 of dual channel modules are 2 x M3. Maximum torque setting is 0.6Nm.

Signals

The signals connector (both primary option and module signals) should be connected using

| | |
|------------------|--------------------|
| | Molex Part Numbers |
| Housing: | 51110-0860 |
| Crimp pin: | 50394 |
| Hand Crimp Tool: | 69008-0959 |

or equivalent part from alternative manufacturer

25 housings and 200 crimps are available as a single part number from TDK-Lambda. The part number is 94158.

Pin Definition - Primary Option

| Pin | Function |
|-----|------------------------------|
| 1 | +V standby |
| 2 | 0V Standby |
| 3 | EN/ES & IN/IS Logic 1 |
| 4 | EN/ES & IN/IS Logic 0 |
| 5 | Global Module Good Collector |
| 6 | Global Module Good Emitter |
| 7 | AC good Collector |
| 8 | AC good Emitter |

See "SIGNALS" section of Application note for use of these signals.

Pin Definition – Secondary Signals

| Pin | Channel | Function | |
|-----|---------|----------------|----------------------|
| 1 | 2 | 0V | Only on twin modules |
| 2 | 2 | Output Good | Only on twin modules |
| 3 | 2 | On/Off | Only on twin modules |
| 4 | | Module Inhibit | |
| 5 | 1 | 0V | |
| 6 | 1 | Output Good | |
| 7 | 1 | Remote Sense - | |
| 8 | 1 | Remote Sense + | |

See "SIGNALS" section of Application note for use of these signals.

MOUNTING

Refer to the handbook for permitted mounting orientation.