

GXE600 SERIES

COMMUNICATION MANUAL

BEFORE USING THE POWER SUPPLY UNIT

Be sure to read this instruction manual thoroughly before using this product. Pay attention to all cautions and warnings before using this product. Incorrect usage could lead to an electrical shock, damage to the unit or a fire hazard.

DANGER

Never use this product in locations where flammable gas or ignitable substances are present.

INSTALLATION WARNING

- When installing, ensure that work is done in accordance with the instruction manual. When installation is improper, there is risk of electric shock and fire.
- Installation shall be done by Service personnel with necessary and appropriate technical training and experience. There is a risk of electric shock and fire.
- Do not cover the product with cloth or paper etc. Do not place anything flammable around. This might cause damage, electric shock or fire.

WARNING on USE

- Do not touch this product or its internal components while circuit in operation, or shortly after shutdown. You might receive a burn.
- While this product is operating, keep your hands and face away from it as you may be injured by an unexpected situation.
- For products with no cover, do not touch them as there are high-voltage and high temperature parts inside. Touching them might cause injury such as electric shock or burn.
- There are cases where high voltage charge remains inside the product. Therefore, do not touch even if they are not in operation as you might get injured due to high voltage and high temperature. You might also get electric shock or burn.
- Do not make unauthorized changes to this product nor remove the cover as you might get an electric shock or might damage the product. We will not be held responsible after the product has been modified, changed or dis-assembled.
- Do not use this product under unusual condition such as emission of smoke or abnormal smell and sound etc. Please stop using it immediately and shut off the product. It might lead to fire and electric shock. In such cases, please contact us. Do not attempt repair by yourself, as it is dangerous for the user.
- Do not operate and store these products in environments where condensation occurs due to moisture and humidity. It might lead fire and electric shock.
- Do not drop or apply shock to this product. It might cause failure. Do not operate these products mechanical stress is applied.

CAUTION on MOUNTING

- Confirm connections to input/output terminals are correct as indicated in the instruction manual before switching on.
- Input/output line, please use the wires as short and thick as possible.
- Do not use this product in special environment with strong electromagnetic field, corrosive gas or conductive substances and direct sunlight, or places where product is exposed to water or rain.
- Mount this product properly in accordance with the instruction manual, mounting direction and shall be properly be ventilated.
- Please shut down the input when connecting input and output of the product.
- When installing in environment where conductive foreign, dust and liquid might be present, please consider penetration of above foreign material in the power supply by installing filter, to prevent trouble or malfunction.

⚠ CAUTION on USE

- Product individual notes are shown in the instruction manual. If there is any difference with common notes individual notes shall have priority.
- Before using this product, be sure to read the catalog and instruction manual. There is risk of electric shock or damage to the product or fire due to improper use.
- Input voltage, Output current, Output power, ambient temperature and ambient humidity should be kept within specifications, otherwise the product will be damaged, or cause electric shock or fire.
- If the built-in fuse is blown, do not use the product even after replacing the fuse as there is risk of abnormality inside. Be sure to request repair to our company.
- For products without built-in protection circuit (element, fuse, etc.), insert fuse at the input to prevent smoke, fire during abnormal operation.
 As for products with built-in protection circuit, depending on usage conditions, built-in protection circuit might not work. It is recommended to provide separate proper protection circuit.
- For externally mounted fuse do not use other fuses aside from our specified and recommended fuse.
- This product was made for general purpose electronic equipment use and is not designed for applications requiring high safety (such as extremely high reliability and safety requirements). Even though high reliability and safety are not required, this product should not be used directly for applications that have serious risk for life and physical safety. Take sufficient consideration in fail-safe design (such as providing protective circuit or protective device inside the system, providing redundant circuit to ensure no instability when single device failure occurs).
- When used in environments with strong electromagnetic field, there is possibility of product damage due to malfunction.
- When used in environment with corrosive gas (hydrogen sulfide, sulfur dioxide, etc.), there is possibility that they might penetrate the product and lead to failure.
- When used in environments where there is conductive foreign matter or dust, there is possibility of product failure or malfunction.
- Provide countermeasure for prevention of lightning surge voltage as there is risk of damage due to abnormal voltage.
- Connect together the frame ground terminal of the product and the ground terminal of the equipment for safety and noise reduction. If these grounds are not connected together, there is risk of electric shock.
- Parts with lifetime specifications (built-in electrolytic capacitor) are required to be replaced periodically. Set the overhaul period depending on the environment of usage and perform maintenance.
 Also, note that there are cases when EOL products cannot be overhauled.
- Take care not to apply external abnormal voltage to the output. Especially, applying reverse voltage or overvoltage more than the rated voltage to the output might cause failure, electric shock or fire.
- This product has possibility that hazardous voltage might occur in output terminal depending on failure mode. The output of these products must be protected in the end use equipment to maintain SELV.
- The output of these product is considered to be a hazardous energy level (The voltage is 2V or more and the power is 240VA or more). It must not be made accessible to users.
- Protection must be provided for Service Engineers against indirect contact with the output terminals and/or to prevent tools being dropped across them.
- While working on this product, the AC input power must be switched off and the input and output voltage should be zero.

⚠ Special Instructions for IEC/EN/ES/CSA 60601-1

- These products are designed for continuous operation within an overall enclosure, and must be mounted such that access to the mains terminals is restricted.
- These products are not suitable for use in the presence of flammable anesthetics mixtures with air or with oxygen, or with nitrous oxide.
- The output circuit has not evaluated for connecting to Applied Parts. For end products intended to connect the output circuit to Applied Parts, suitable evaluation of the separation, leakage current, dielectric voltage withstand, and related requirements should be conducted.
- Doublepole/ neutral fusing.  Option model “/SF” have fuse only live line.
- These products provide One Means Of Patient Protection (1MOPP) between Primary/Secondary and FG, and Two Means Of Patient Protection (2MOPP) between Primary and Secondary.

- The 48V model have possibility that hazardous voltage might occur in output terminal depending on failure mode (The output voltage is 60V or more on failure mode). The output of these products must be protected in the end use equipment. If it is not acceptable, contact us.
- These products are classed as ordinary equipment according to IEC/EN/ES/CSA60601-1 and are NOT protected against the ingress of water.
- Reference should be made to local regulations concerning the disposal of these products at the of their useful life.

 **Note**

- Take note that traces of sheet metal processing be left in our power supplies.
- When disposing product, follow disposal laws of each municipality.
- Published EMI (CE, RE) or immunity is the result when measured in our standard measurement conditions at the factory default and might not satisfy specification when various settings are changed from the factory default or mounted and wired inside end-user equipment. Use the product after sufficiently evaluating at actual end-user equipment.
- When exporting our products, apply for necessary permissions as required by rules and regulations of Foreign Exchange and Foreign Trade Control Act.
- Catalogue, contents of the instruction manual might be changed without a prior notice. Refer to latest catalogue or instruction manual.
- Reproduction or reprinting the instruction manual or its portion is forbidden without our permission.
- CE Marking
CE Marking, when applied to a product covered by this handbook, indicates compliance with the low voltage directive.

 **LONG-TERM STORAGE METHOD AND LONG-TERM STORAGE PERIOD**

- Please keep the product in carton box.
- Please do not apply excessive vibration, shock or mechanical stress applied directly to the product.
- Please keep away from direct sunlight.
- For long-term storage temperature and humidity, the following conditions shall be used as a guideline :
Temperature range : 5°C~30°C
Humidity range : 40%~60%RH
Please keep away from the places where temperature and humidity can change drastically.
It can cause condensation on the product or deterioration.
- For long-term storage period, we recommend to use within 2 years after receiving the product.
There is tendency that the leakage current of an aluminum electrolytic capacitor may increase when stored without using for a long time.
This phenomenon can be improved by applying voltage to the aluminum electrolytic capacitor to reduce the increased leakage current through the self-recovery effect of the electrolyte.
For reference, before using products that have been stored for a very long time, please warm-up first for 30 minutes or more without taking load.
< Criterion of warm up voltage condition >
(1)Implementation period : 1 year or above after the delivery
(2)Electrical continuity condition
Input voltage : Rating
Load : 0A
Ambient temperature : Normal temperature
Time : 30 minutes or more

Contents

1. Overview
2. Wiring / connection of communication system
 - 2.1 Communication terminal of GXE series
 - 2.2 Connection with host device
 - 2.3 Setup of GXE
3. Communication specification
 - 3.1 Transmission specification
 - 3.2 Communication protocol
 - 3.3 GXE supported function code
 - 3.4 GXE support diagnosis function
4. GXE MODBUS Register
 - 4.1 Input Register List
 - 4.2 Holding Register List
 - 4.3 Input Register Details
 - 4.4 Holding Register Details

Supplementary

1. Overview

GXE series use MODBUS protocol with RS-485 physical layer for communication.

Transmission mode of MODBUS protocol is supported only by MODBUS-RTU (MODBUS-ASCII is not supported).

MODBUS use the single master / multi-slave communication method. In MODBUS protocol, only the master device sends the query, and the slave device specified (unicasted) by master device return the response.

In the case of queries to all slave devices (broadcast), each slave device performs query processing but does not return the response. If the slave device receives the incorrect query frame, the slave device discards the query and waits for the next query.

GXE operates as a MODBUS slave device.

By MODBUS communication, it is possible to monitor the operation status and to change various settings of GXE.

2. Wiring / connection of communication system

2.1 Communication terminal of GXE series

The terminal name and function are shown below.

CN84	Name	Function
19	+DATA	Differential data +
20	-DATA	Differential data -
17	SG	Signal Ground

+/- DATA and SG are isolated (Withstand voltage: 100 V, Functional insulation) from GXE's secondary output and CN84's Pin number 1-10. For details, refer to "3. Block diagram" in the instruction manual.

2.2 Connection with host device

The example connection to host (master) device is shown below.

Before connecting, it is necessary to set a unique slave ID for each GXE.

At factory setting, the slave ID of GXE is set to "1".

If plural GXEs are connected without changing the slave ID, all GXEs respond to the same query, so that normal response cannot be obtained. Set up GXE and assign unique slave ID.

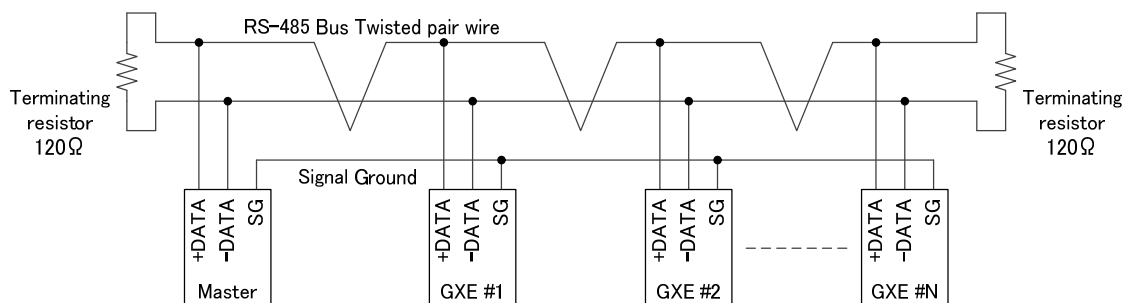

Be sure to connect the data line [+ DATA / - DATA] with a twisted pair wire.

GXE does not have built-in terminating resistor for RS-485 in the device.

Connect the terminating resistor to both the physical ends of the RS-485 bus line.

The terminating resistor connected to the device furthest from the master and RS-485 port of the master device.

The master device may have built-in terminating resistor.

Refer to the instruction manual of the master device for setting the terminating resistance of the master device.

When terminating resistor is not connected, the frequency of communication errors may increase or communication may become impossible at worst case.

Bias of the data line should be performed on the master side as necessary.

2.3 Setup of GXE

When connecting plural GXEs to the system, each GXE must have a unique slave ID.

Before installing into the system, set each GXE so that the slave ID does not overlap.

To do setup, you can connect PC and GXE one to one with RS-485 line and execute our communication tool on PC.

Refer to the communication GUI guide for installation and operation method of communication tool.

Prepare USB ⇔ RS-485 converter for PC. It can be used as long as it is an RS-485 converter compatible with half duplex communication and automatic transmission control.

The USB ⇔ RS-485 converter we confirmed the operation is "USB-003 made by Human Data Ltd."

Refer to the instruction manual for information of connector / cable wire diameter etc. used for connection.

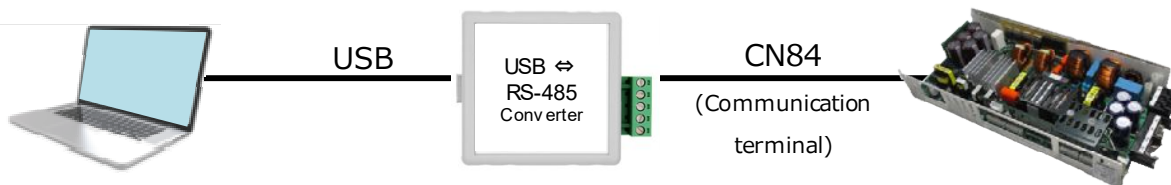

•Connection

When connecting, be sure to connect 1)CN84 ⇒ 2)USB cable in order.

After completing the connection of the communication line, apply input voltage.

Do not perform operations such as disconnection of the communication line and attachment / detachment of the connector while apply input and communication tool is running.

Even if the input is cut off, there is a possibility that electric charge may remain at the output terminal.

Be careful when removing the communication line.

•Communication configuration

Factory default communication configuration is shown below.

Default communication configuration

Item	Default value
Slave ID	ID : 1
Baud rate	19200 bps
Data length	8 bit
Parity	Even parity
Others	Start : 1 bit / Stop : 1 bit / LSB first

•Change communication configuration

In addition to changing the slave ID, change the communication configuration to suit system as necessary.

It is possible to send necessary queries from the master device and change the settings.

There is no slave ID display function in the GXE.

Do not forget the changed settings.

3. Communication specification

3.1 Transmission specification

The transmission specification is shown below.

#	Item	Specification																
1	Electrical specifications																	
1.1	Signal Ground	Isolated Functional isolation from the device secondary output. (COM, -S, -Vo, -Vm)																
1.2	Transceiver voltage	5V																
1.3	Transmission standard	TIA / EIA-485																
1.4	Connection type	1 (Master) : N (Slave) [$N \leq 15$] The maximum number of connectable units is not necessarily guaranteed. It depends on the quality of the communication line.																
1.5	Transmission mode	Half Duplex																
1.6	Total transmission path length	100m or less																
2	Character transmission specification																	
2.1	Synchronization method	Asynchronous																
2.2	Baud rate	2400 / 4800 / 9600 / 19200(Factory setting) [bps] + / - 2 % error tolerance																
2.3	Transmission code composition	The following combinations are valid <table border="1" style="margin-left: auto; margin-right: auto;"> <thead> <tr> <th>Length</th> <th>Parity</th> <th>Start</th> <th>Stop</th> </tr> </thead> <tbody> <tr> <td>8 bit</td> <td>Even</td> <td>1 bit</td> <td>1 bit</td> </tr> <tr> <td>8 bit</td> <td>Odd</td> <td>1 bit</td> <td>1 bit</td> </tr> <tr> <td>8 bit</td> <td>None</td> <td>1 bit</td> <td>2 bit</td> </tr> </tbody> </table> * Factory setting	Length	Parity	Start	Stop	8 bit	Even	1 bit	1 bit	8 bit	Odd	1 bit	1 bit	8 bit	None	1 bit	2 bit
Length	Parity	Start	Stop															
8 bit	Even	1 bit	1 bit															
8 bit	Odd	1 bit	1 bit															
8 bit	None	1 bit	2 bit															
2.4	Transfer order	LSB first																
2.5	Flow control	None																
2.6	Character transfer interval	Less than T1.5 Char (Receiving can accept more than T1.5 Char)																
3	Protocol specification																	
3.1	Format	MODBUS-RTU																
3.2	Transmission procedure	MODBUS-RTU																
3.3	Interval	T7 Char (min) T1 Char = 11 / Transfer speed (= 573 us : At the 19200 bps)																
3.4	Response time	Query processing time (From the end of the query frame to the start of the response) Uni-cast : 50ms or less Broadcast : 100ms or less (= Turn around time) Wake up time : 300ms or less (Leave sleep mode and wait for reception)																

* Time precision is less than $\pm 1\%$ (Total operating temperature range $-20 \sim 70^{\circ}\text{C}$)

3.2 Communication protocol

3.2.1 Protocol overview

MODBUS use the single master / multi-slave communication method.

In MODBUS protocol, only the master device sends the query, and the slave device specified(unicasted) by master device return the response after completion of query processing.

The slave device sends an exception response message when query processing terminates abnormally.

Messages with transmission errors detected are discarded.

If a transmission error occurs in the query message, the slave discards the query message, so that no response message is sent. In this case, the master device should detect communication timeout and perform appropriate processing such as message retransmission.

In the case of queries to all slaves (broadcast), each slave performs query processing but does not return the response. The master device should send the following query after the "Turn around time" has elapsed.

Examples of exchanging messages between master and slave are shown below.

Uni-cast normal response

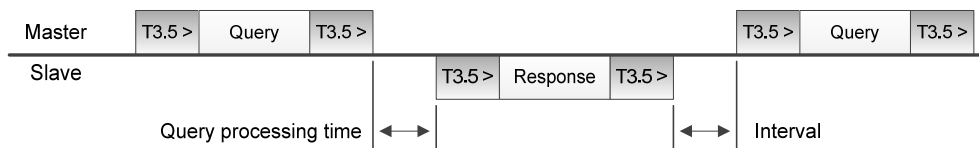

Broadcast normal operation

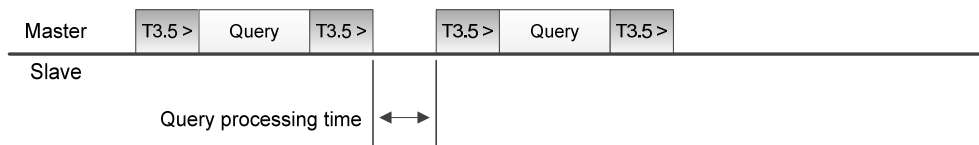

"Turn around time" is the time the master device must wait to complete the query processing of the slave device when issuing the broadcast query. It is normally specified by the communication specification of the slave device. Set the communication timeout of the master device to 100ms or more in consideration of the query processing time of the slave device.

For the detailed specification of the MODBUS protocol, refer to the following document.

Publisher : Modbus Organization (<http://modbus.org/>)

MODBUS APPLICATION PROTOCOL SPECIFICATION V1.1b (Modbus_Application_Protocol_V1_1b3.pdf)

MODBUS over Serial Line Specification and Implementation Guide V1.02 (Modbus_over_serial_line_V1_02.pdf)

GXE does not support some items of the above specifications.

- 1 Frame delimitation is simpler than the original specification.
 When the frame interval is within T7 character time, it is recognized as one frame.
 (Frame delimitation is judged at any timing within the range of T3.5 character time to T7 character time)
 Usually, it is no problem because "communication timeout time >> T7 character time".
- 2 Character reception interval error (reception interval > T1.5 character time) is not detected.
 When the character reception interval is within the frame delimiting time, it is recognized as one frame.
 Usually, since the serial port of the master device transmits without sending the character interval, there is no problem in the actual operation.
- 3 The frame size that GXE can accept is 64 bytes. (Maximum size of protocol specification is 256 bytes)
- 4 Only function codes for 16 bit registers are supported.
- 5 An exception response is returned to a query of which start address is not listed in the register list.

3.2.2 Message frame composition

In MODBUS-RTU, the part of the message frame where data is actually transmitted is denoted as ADU (serial line Application Data Unit). Also, in the transmission data, the data part interpreted by the protocol part is denoted as PDU (Protocol Data Unit).

1) Query frame

The query message frame of MODBUS-RTU consists of the following fields.

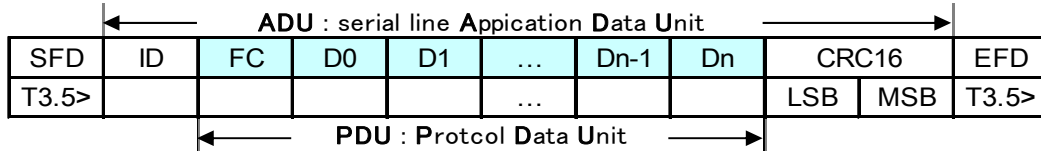

•SFD (**S**tart **F**rame **D**elimiter) : Silent interval longer than T3.5 character time (no communication time)

•ID (slave **ID**) : One byte from 0 to 247 that designates the slave device to be communicated

ID	Meaning
0	Broadcast ID
1 - 247	Individual slave ID
248 - 255	Reserved

•FC (**F**unction **C**ode) : Use b0 - b6 bits as FC (0x00 - 0x7F)

•Dx (**D**ata bytes) : Data field (multibyte data is big endian)

The following byte order is applied to each data type in GXE.

Data type	Byte order			
16bit type	Upper byte	Lower byte		
32bit type	Upper byte of upper word	Lower byte of upper word	Upper byte of lower word	Lower byte of lower word
String type	C0	C1	...	Cn
	Cx is character byte			

Example) 32bit data type "0x12345678" ⇒ D0 : 0x12, D1 : 0x34, D2 : 0x56, D3 : 0x78

The data byte order of the frame does not necessarily match the endian of the master device processor.

•CRC16 (**C**yclical **R**edundancy **C**hecking) :16 bit cyclic redundancy check from ID to Dn

The CRC of MODBUS-RTU is the so-called "Reverse type 16 bit CRC-IBM".

Generator polynomial : 0xA001 (Inverted 0x8005)

CRC initial value : 0xFFFF

Final XOR operation : NONE

Example) Send a Input register read query (FC:0x04) with PDU address 0x0001 and number of registers 3 to slave device (ID:1)

	SFD	ID	FC	D0	D1	D2	D3	CRC16	EFD
T3.5>	0x01	0x04	0x00	0x01	0x00	0x03	0xE1	0xCB	T3.5>

Generated CRC : 0xCBE1

For details, refer to chapter 6.2.2 of "MODBUS over Serial Line Specification and Implementation Guide".

Because the CRC field is little-endian (order of lower byte, upper byte), pay attention to the transmission order.

•EFD (**E**nd **F**rame **D**elimiter) : Silent interval longer than T3.5 character time (no communication time)

2) Response frame

The response message frame of MODBUS-RTU consists of the following fields.

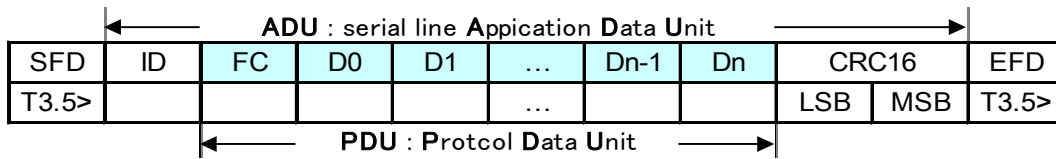

The structure of each field is the same as the query frame, but the value of the ID field is limited to the individual slave ID (1 - 247).

3) Exception response frame

The exception response message frame of MODBUS-RTU consists of the following fields.

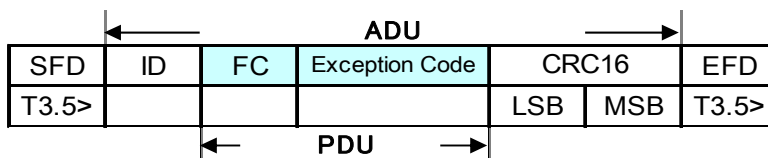

The configuration is the same as the query frame except for the following fields.

- FC (Function Code) : For the exception response, use the query FC + 0x80

Example) Exception response FC to query FC 0x10 ⇒ 0x90

- Exception code : 1 byte code indicating the content of the exception

In the case of GXE, the following exception code may be returned.

Code	Name	Contents
0x01	ILLEGAL FUNCTION	Unsupported function code
0x02	ILLEGAL DATA ADDRESS	Undefined register address (including reserved address)
0x03	ILLEGAL DATA VALUE	Invalid data
0x04	SLAVE DEVICE FAILURE	Slave device error
0x06	SLAVE DEVICE BUSY	Slave device busy

3.2.3 Sleep mode

GXE has a sleep mode. Refer to section 6-17 of the instruction manual for sleep mode conditions.

Sleep mode contributes to reduction of standby power, but communication function cannot be used during sleep mode.

In sleep mode, GXE will resume normal operation by the signal on RS-485 as a trigger.

At this time, the content of the signal does not matter, but GXE cannot receive the contents of the signal, so that the response will not be returned. Send the query again from the master device after the wake up time as shown in the example below.

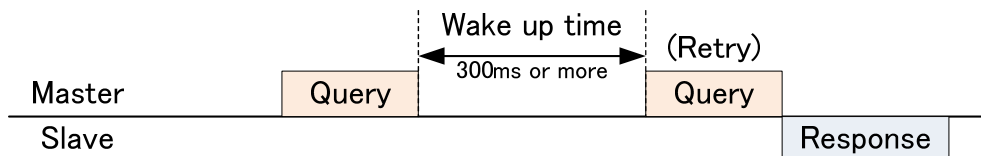

3.3 GXE supported function code

GXE supports the following function codes (FC).

Data Type	FC	Function name
16 bit	4 (0x04)	Read Input register
16 bit	3 (0x03)	Read Holding register
16 bit	6 (0x06)	Write single Holding register
16 bit	16 (0x10)	Write multi Holding register
16 bit	23 (0x17)	Read/Write multi Holding register

For simplification, each query is described with only PDU in the following explanation.

Any queries for the actual communication line must be sent with ADU (ID + PDU + CRC).

3.3.1 FC : 4 (0x04) Read Input register

The read content of consecutive Input registers.

Broadcast is invalid.

•Request PDU

Field	Number of bytes	Field value
Function code	1	0x04
Starting Address	2	Refer to 4.Register list
Quantity of Registers	2	1 ~ 15 (0x000F) *

* It is necessary to specify according to the actual register arrangement

•Response PDU

Field	Number of bytes	Field value
Function code	1	0x04
Number of data bytes	1	2 x N
Register data	N x 2	Read data

N =Quantity of Registers specified in the query

•Error PDU

Field	Number of bytes	Field value
Function code	1	0x84
Exception code	1	Refet to 3.2.2

It can be used for data acquisition of single register, multi-register block and consecutive register block.

If a reserved address is included in the specified register address section [start address ~ (start address + number of registers - 1)], an exception response [Exception code 0x02: ILLEGAL DATA ADDRESS] is returned.

Even if the start address or the number of registers is invalid, an exception response [Exception code 0x02: ILLEGAL DATA ADDRESS] is returned.

Exception response [Exception code 0x03: ILLEGAL DATA VALUE] is returned if the Request PDU size is not the valid size (5 bytes).

•Message exchange example

The Read the Input register for three words from the start address 4d (0x0004)

Query		Response	
Field	[HEX]	Field	[HEX]
Function code	0x04	Function code	0x04
Start address Hi	0x00	Number of data bytes	0x06
Start address Lo	0x04	Register 0x0004 Hi	0x00
Number of registers Hi	0x00	Register 0x0004 Lo	0x23
Number of registers Lo	0x03	Register 0x0005 Hi	0x1A
		Register 0x0006 Lo	0x47
		Register 0x0006 Hi	0x1F
		Register 0x0006 Lo	0x40

It means the following contents from above response data.

Power cumulative operating time : 0x231A47 = 2300487 s

Remaining life of electrolytic capacitor : 0x1F40 = 8000 h

3.3.2 FC : 3 (0x03) Read Holding register

The Read content of consecutive Holding registers.

Broadcast is invalid.

•Request PDU

Field	Number of bytes	Field value
Function code	1	0x03
Starting Address	2	Refer to 4.Register list
Quantity of Registers	2	1 ~ 16 (0x0010) *

* It is necessary to specify according to the actual register arrangement

•Response PDU

Field	Number of bytes	Field value
Function code	1	0x03
Number of data bytes	1	2 x N
Register data	N x 2	Read data

N =Quantity of Registers specified in the query

•Error PDU

Field	Number of bytes	Field value
Function code	1	0x83
Exception code	1	Refer to 3.2.2

It can be used for data acquisition of single register, multi-register block and consecutive register block.

If a reserved address is included in the specified register address section [start address ~ (start address + number of registers - 1)], an exception response [Exception code 0x02: ILLEGAL DATA ADDRESS] is returned.

Even if the start address or the number of registers is invalid, an exception response [Exception code 0x02: ILLEGAL DATA ADDRESS] is returned.

Exception response [Exception code 0x03: ILLEGAL DATA VALUE] is returned if the Request PDU size is not the valid size (5 bytes).

•Message exchange example

The Read the Holding register for two words from the start address 100d (0x0064)

Query		Response	
Field	[HEX]	Field	[HEX]
Function code	0x03	Function code	0x03
Start address Hi	0x00	Number of data bytes	0x04
Start address Lo	0x64	Register 0x0064 Hi	0x0A
Number of registers Hi	0x00	Register 0x0064 Lo	0x01
Number of registers Lo	0x02	Register 0x0065 Hi	0x00
		Register 0x0065 Lo	0x03

It means the following contents from above response data.

Remote control configuration : 0x0A01

CVCC reference configuration : 0x0003

3.3.3 FC : 6 (0x06) Write single Holding register

The Updates the content of a single Holding register.

If the specified register is supported non-volatile memory, it is updated as non-volatile data.

Broadcast is valid.

•Request PDU

Field	Number of bytes	Field value
Function code	1	0x06
Starting Address	2	Refer to 4.Register list
Register data	2	Write data

•Response PDU

Field	Number of bytes	Field value
Function code	1	0x06
Starting Address	2	Refer to 4.Register list
Register data	2	Write data echo back

•Error PDU

Field	Number of bytes	Field value
Function code	1	0x86
Exception code	1	Refer to 3.2.2

It can be used to update data of a single register.

If the specified start address is a reserved address, an exception response [Exception code 0x02: ILLEGAL DATA ADDRESS] is returned.

Exception response [Exception code 0x03: ILLEGAL DATA VALUE] is returned if the Request PDU size is not the valid size (5 bytes) or the register data is out of the allowable range.

When an exception response occurs, non-volatile memory is not updated.

•Message exchange example

The Write data 0x0001 to the Holding register at start address 5d (0x0005)

Query		Response	
Field	[HEX]	Field	[HEX]
Function code	0x06	Function code	0x06
Start address Hi	0x00	Start address Hi	0x00
Start address Lo	0x05	Start address Lo	0x05
Register data Hi	0x00	Register data Hi	0x00
Register data Lo	0x01	Register data Lo	0x01

It means the following contents was updated from above response data

Remote On / Off (Non-Volatile) Register address : 0x0005

Remote On request : 0x0001

3.3.4 FC : 16 (0x10) Write multi Holding register

The Updates the contents of consecutive Holding registers.

If the specified register is supported non-volatile memory, it is updated as non-volatile data.

Broadcast is valid.

•Request PDU

Field	Number of bytes	Field value
Function code	1	0x10
Starting Address	2	Refer to 4.Register list
Quantity of Registers	2	1 ~ 16 (0x0010) *
Number of data bytes	1	2 x N
Register data	N x 2	Write data

N = Number of registers specified in Qty.

* It is necessary to specify according to the actual register arrangement

•Response PDU

Field	Number of bytes	Field value
Function code	1	0x10
Starting Address	2	Refer to 4.Register list
Registers value	2	1 ~ 16 (0x0010)

•Error PDU

Field	Number of bytes	Field value
Function code	1	0x90
Exception code	1	Refer to 3.2.2

It can be used to update data of multi-register block or consecutive register block.

If a reserved address is included in the specified register address section [start address ~ (start address + number of registers - 1)], an exception response [Exception code 0x02: ILLEGAL DATA ADDRESS] is returned.

Even if the start address or the number of registers is invalid, an exception response [Exception code 0x02: ILLEGAL DATA ADDRESS] is returned. Exception response [Exception code 0x03: ILLEGAL DATA VALUE] is returned if the Request PDU size is not a valid size.

When an exception response occurs, non-volatile memory is not updated.

However, if an exception response cause occurs during data update, the value of the register whose write processing was completed before the cause occurred will be updated. (The register value is not restored.)

•Message exchange example

The Write two words data to the Holding register at start address 100d (0x0064)

Query		Response	
Field	[HEX]	Field	[HEX]
Function code	0x10	Function code	0x10
Start address Hi	0x00	Start address Hi	0x00
Start address Lo	0x64	Start address Lo	0x64
Number of registers Hi	0x00	Number of registers Hi	0x00
Number of registers Lo	0x02	Number of registers Lo	0x02
Number of data bytes	0x04		
Register 0x0064 data Hi	0x0A		
Register 0x0064 data Lo	0x00		
Register 0x0065 data Hi	0x00		
Register 0x0065 data Lo	0x01		

It means the following contents was updated from above response data

Remote control configuration : 0x0A00
CVCC reference configuration : 0x0001

3.3.5 FC : 23 (0x17) Read/Write multi Holding register

It performs read / write of consecutive Holding registers with a single query.

Write processing is executed before read processing.

If the specified register is supported non-volatile memory, it is updated as non-volatile data.

Broadcast is invalid.

•Request PDU

Field	Number of bytes	Field value
Function code	1	0x17
Read Starting Address	2	Refer to 4.Register list
Number of read registers	2	1 ~ 16 (0x0010) *
Write Starting Address	2	Refer to 4.Register list
Number of write registers	2	1 ~ 16 (0x0010) *
Number of write bytes	1	2 x N
Write data	N x 2	Write data

N = Number of registers specified in Number of write registers field

* It is necessary to specify according to the actual register arrangement

•Response PDU

Field	Number of bytes	Field value
Function code	1	0x17
Number of read bytes	1	2 x M
Register data	2	Read data

M = Number of registers specified in Number of read registers field of query

•Error PDU

Field	Number of bytes	Field value
Function code	1	0x97
Exception code	1	Refer to 3.2.2

It can be used to update data of multi-register block or consecutive register block.

If a reserved address is included in the specified register address section [start address ~ (start address + number of registers - 1)], an exception response [Exception code 0x02: ILLEGAL DATA ADDRESS] is returned. Even if the start address or the number of registers is invalid, an exception response [Exception code 0x02: ILLEGAL DATA ADDRESS] is returned.

Exception response [Exception code 0x03: ILLEGAL DATA VALUE] is returned if the Request PDU size is not a valid size.

When an exception response occurs, non-volatile memory is not updated.

However, if an exception response cause occurs during data update, the value of the register whose write processing was completed before the cause occurred will be updated. (The register value is not restored.)

•Message exchange example

The Read one words data to the Holding register at start address 102d (0x0066) and the write two words data to the Holding register at start address 100d (0x0064).

Query		Response	
Field	[HEX]	Field	[HEX]
Function code	0x17	Function code	0x17
Read start address Hi	0x00	Number of read bytes	0x02
Read start address Lo	0x66	Register 0x0066 data Hi	0x3F
Number of read registers Hi	0x00	Register 0x0066 data Lo	0x1E
Number of read registers Lo	0x01		
Write start address Hi	0x00		
Write start address Lo	0x64		
Number of write registers Hi	0x00		
Number of write registers Lo	0x02		
Number of write bytes	0x04		
Register 0x0064 data Hi	0x64		
Register 0x0064 data Lo	0x02		
Register 0x0065 data Hi	0x00		
Register 0x0065 data Lo	0x03		

3.4 GXE support diagnosis function

GXE supports some of the diagnostic functions specified by the MODBUS protocol.

Diagnostic functions are Function code(FC) 0x08 query and actual functions are specified in sub code(SC).

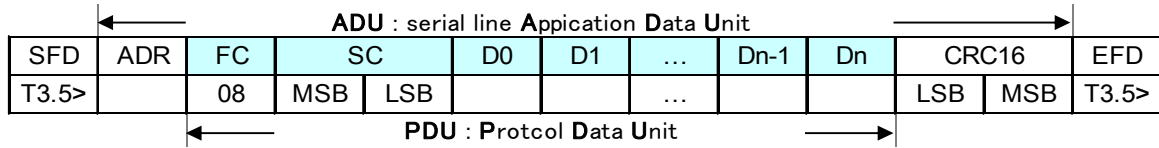

The list of diagnostic functions supported is shown below.

FC	SC	Function name
0x08	0 (0x0000)	Echo back
	1 (0x0001)	Communication reinitialization
	4 (0x0004)	Receive only mode

3.4.1 SC : 0 (0x0000) / Echo back

It is returned the response that echoed the query for the query whose data field is 1 word or more and 29 words less.

•Request PDU

Field	Number of bytes	Value
FC	1	0x08
SC	2	0x0000
Data	N x 2	Query data

N : Number of 16bit data

•Response PDU

Same to Request PDU

3.4.2 SC : 1 (0x0001) / Communication reinitialization

Initialize the GXE communication port according to the setting register value currently held.

The Response is done with existing communication settings before communication port initialization processing.

(In receive only mode, the response is not returned)

By sending this query, it is possible to change only the communication settings while maintaining the connection status with GXE.

•Request PDU

Field	Number of bytes	Value
FC	1	0x08
SC	2	0x0001
Data	2	0x0000 or 0xFF00

*A query other than the described data becomes an exception response.

•Response PDU

Same to Request PDU

3.4.3 SC : 4 (0x0004) / Receive only mode

Set GXE to receive only mode.

When set to this mode, GXE ignores all queries and does not perform actions or responses.

However, only diagnostic subcode 0x0001 is accepted, the communication port is initialized and restarted, and the receive only mode is canceled.

•Request PDU

Field	Number of bytes	Value
FC	1	0x08
SC	2	0x0004
Data	2	0x0000

*A query other than the described data becomes an exception response.

•Response PDU

Diagnosis subcode: 4 query will not return response. (Timeout of host device)

4. GXE MODBUS Register

In GXE, Input Register and Holding Register of 16-bit data are used in the data model specified by MODBUS protocol. Discrete Register and Coil Register of 1 bit data are not used.

The register address of GXE in this communication manual is indicated by the PDU address.

If a register that does not exist is used as the starting address, it becomes an exception response.

•Numerical notation

Numbers starting with '0x' indicate hexadecimal numbers. (Example : 0x0400 = 1024d)

Decimal numbers are indicated by appending 'd' after the value or without adding anything. (Example : 1024d , 1024)

Binary numbers are indicated by appending '0b' before the value. (Example : 0b0100 0000 0000 = 1024d)

The internal data type of GXE is 16 bit little endian. (LSB: bit 0 / MSB: bit 15)

Negative values are represented in two's complement.

4.1 Input Register List

Input Registers are read-only 16-bit data registers.

Mainly, Input Registers has measurement data.

Broadcast is invalid.

Data read is possible with function code: 0x04.

Refer to supplementary items for Q format.

#	Input Register	Starting Address	Qty	Function
1	Alarm History (Volatile)	0 (0x0000)	1	Indication of the history of protection occurrence. It is cleared when "remote on" from "remote off" state.
2	Output Voltage	1 (0x0001)	1	Monitor value of output voltage (between +S and -S). Normalized Q10
3	Output Current	2 (0x0002)	1	Monitor value of output current. Normalized Q10
4	Internal Temperature	3 (0x0003)	1	Monitor value of internal temperature[°C] in power supply.
5	Operation Time	4 (0x0004)	2	Monitor value of cumulative operating time.
6	E-cap L0 Remaining	6 (0x0006)	1	Indication of the remaining lifetime of the electrolytic capacitor, which is the most degraded in the GXE.
7	Analog CV Reference * ¹	7 (0x0007)	1	Monitor value of analog PV voltage terminal. Normalized Q10
8	Analog CC Reference * ¹	8 (0x0008)	1	Monitor value of analog CC current terminal. Normalized Q10
9	PF Output Time * ¹	9 (0x0009)	1	Monitor value of cumulative time while the PF signal is out.

Continued on next page

#	Input Register	Starting Address	Qty	Function
10	Alarm History (Volatile) * ¹	20 (0x0014)	1	Same function as the #1.
11	Alarm History (Non-Volatile) * ¹	21 (0x0015)	1	Indication of the history of protection occurrence. This history would be held until the execution of clear by sending request to the "Clear Alarm History Register".
12	Model Name	500 (0x01F4)	15	Strings of device model name. [ASCII]
13	Serial No.	520 (0x0208)	8	Strings of device serial number. [ASCII]
14	Lot No.	540 (0x021C)	8	Strings of device lot number. [ASCII]
15	Firmware Ver.	1000 (0x03E8)	1	Indication of the Firmware version.

*¹ #7-#11 registers are not available for the firmware version 3.000 and 3.001 product.

4.2 Holding Register List

Holding Registers are readable / writable 16-bit data registers.

Mainly, Holding Registers has settable data.

Each setting value is retained even if the GXE input is shut down unless otherwise specified.

Broadcast is invalid for read queries.

Data read is possible with function code: 0x03.

Data write is possible with function code: 0x06 or 0x10.

Data read / write is possible with function code: 0x17.

#	Holding Register	Starting Address	Qty	Function
1	Remote On/Off (Volatile)	0 (0x0000)	1	Communication remote On/Off control. Value is volatile.
	Remote On/Off (Non-Volatile)	5 (0x0005)	1	Communication remote On/Off control. Value is non-volatile.
2	Remote Control Configuration	100 (0x0064)	1	Remote On/Off control configuration. It is possible to set remote control ON/OFF mode and remote control ON/OFF terminal input sensitivity.
3	CVCC Reference Configuration	101 (0x0065)	1	It is possible to select either "Analog CV/CC Reference" or "Digital CV/CC Reference".
4	Protect Configuration	102 (0x0066)	1	Protection mode configuration. It is possible to select either "Auto Recovery" or "Latch stop".
5	Digital CV Reference	103 (0x0067)	1	Digital reference value of output voltage. Normalized Q10 volts
6	Digital CC Reference	104 (0x0068)	1	Digital reference value of output current. Normalized Q10 amps
7	Over Voltage Threshold	105 (0x0069)	1	Threshold value of output over voltage. Normalized Q10 volts
8	Over Current Threshold	106 (0x006A)	1	Threshold value of output over current. Normalized Q10 amps
9	CV Rising Time	107 (0x006B)	1	Voltage slew rate at output start
10	CC Rising Time	108 (0x006C)	1	Current slew rate at output start
11	CV Transition Time	109 (0x006D)	1	Slew rate of the CV reference value when the CV reference is changed.
12	CC Transition Time	110 (0x006E)	1	Slew rate of the CC reference value when the CC reference is changed.
13	PF Threshold	111 (0x006F)	1	Threshold value of Power Fail signal. The threshold is specified as a percentage of the CV / CC reference value as 100%. The CV / CC reference value is selected in the "PF mode" register.

Continued on next page

#	Holding Register	Starting Address	Qty	Function
14	PF mode	112 (0x0070)	1	"Power Fail" detection mode setting. It is possible to select "Power Fail" detection target either "Output voltage" or "Output current".
15	PF Count	113 (0x0071)	1	"Power Fail" detection sensitivity setting. It is possible to specify "PF" sensitivity in units of milliseconds.
16	Auto Recovery Time	114 (0x0072)	1	Automatic recovery time setting when protection is activated. It is possible to specify "Automatic recovery time" in units of 10 milliseconds.
17	Clear Alarm History	115 (0x0073)	1	Alarm history clear register. This register is write-only. An exception response is returned when reading this register.
18	Clear PF Output Time * ²	116 (0x0074)	1	PF output time clear register. This register is write-only. An exception response is returned when reading this register.
19	Slave ID * ¹	200 (0x00C8)	1	Software Slave ID. ID : 1 to 247 is available. Broadcast query is invalid. This is to avoid duplicate address setting.
20	Baud Rate * ¹	201 (0x00C9)	1	Baud Rate Configuration.
21	Parity * ¹	202 (0x00CA)	1	Parity Bit Configuration.
22	Scratch Pad1	300 (0x012C)	15	It is a register that customers can freely store data. Up to 30 characters of data can be stored in ASCII characters. Valid as data other than readable characters.
	Scratch Pad2	320 (0x0140)	15	

*¹ It influences setting change in the slave Address, the Baud Rate and the parity setting register at the time of initialization of a GXE communication port.
The timing to initialize the communication port is as follows.

- a. When re-input.
 - b. When query is issued with diagnostic function subcode 0x0001.
- Therefore it does not become influence immediately even if setting is changed.

*² #18 register is not available for the firmware version 3.000 and 3.001 product.

4.3 Input register details

In this chapter, Details about functions of the input registers in GXE is described.

•Explanatory notes

Attributes assigned to registers

Address allocated to register

Number of words allocated to register

It is indicated the supported non-volatile, whether data is retained even after input shutdown

Yes : Data is retained even after input is shut down.
No : Data is deleted after input is shut down.

#	1	Register Name	Alarm History	
Data Type	Register Function	Starting Address	Qty	Non-volatile
Input	Alarm history indicator	0 (0x0000)	1	No

1) Register Details

This Register indicates the protection that occurred from output start to next output start.
"Alarm history" data is in bitmap format.
"1" is set when corresponding bit protection operation is occurred.
The protection assigned to each bit is shown in the table below.

Bit	Name	Description	Remarks
0	SWOCP	Indication of over current protection in the past.	It is possible to change the threshold.
1	HWOCP	Indication of over current protection in the past.	"HWOCP" responds faster than "SWOCP" and the threshold is far.
2	SWOVP	Indication of over voltage protection in the past.	It is possible to change the threshold.
3	HWOVP	Indication of over voltage protection in the past.	It operates at about 125% typ(fixed) of rated.
4	OTP	Indication of over temperature protection in the past.	-
5	PFCLVP	Indication of voltage drop in the boost section	It might be 1, when remote off due to the boost operation stopping.
8	CNTOFF	Indication of remote off.	-
9-13	SYSTEM	Indication of internal error in the past.	Contact our support when an error occurs.
6, 7, 14, 15	Reserved	Reserved	-

Example : In case of "Remote off" after "Output over current".
bit 0 : SWOCP, bit 5 : PFCLVP, bit 8 : CNTOFF is set. ⇒ Register value : 0x0121

To clear alarm history, perform the following operations.
A. The Write clear request to "Clear Alarm History" register.
It will be cleared as soon as the query is received.
B. "Remote on" after "Remote off"
The latch is released with the output start, and the alarm history is also cleared.

The alarm history cannot be cleared when protection is continued.
Because the bit is set again.

2) Register Read

Request PDU		Read Inputs.
Field	Byte	Value
Function code	1	0x04
Starting Address	2	0 (0x0000)
Quantity of Registers	2	1(0x0000)

Response PDU		Read Inputs.
Field	Byte	Value
Function code	1	0x04
Byte count	1	2 (2 x 1)
Registers value	2	Reading data.

Error PDU		Read Inputs.
Field	Byte	Value
Function code	1	0x04
Exception code	1	0x02

Details of the register function

Packet frame configuration at register access

The packet frame described on each page is an example of access to one register.
Multiple access is possible when the register address assignment is continuous.

1, 10 **Register Name Alarm History (Volatile)**

Data Type	Register Function	Starting Address	Qty	Non-volatile
Input	Alarm history indicator	0 (0x0000)	1	No
Input	Alarm history indicator	20 (0x0014)	1	No

* One of the register (start address: 0x0014) is not available for firmware version 3.000 and 3.001 product.

1) Register Details

This Register indicates the protection that occurred from output start to next output start.

"Alarm history" data is in bitmap format.

"1" is set when corresponding bit protection operation is occurred.

The protection assigned to each bit is shown in the table below.

Bit	Name	Description	Remarks
0	SWOCP	Indication of over current protection in the past.	It is possible to change the threshold.
1	HWOCP	Indication of over current protection in the past.	"HWOCP" responds faster than "SWOCP" and the threshold is far.
2	SWOVP	Indication of over voltage protection in the past.	It is possible to change the threshold.
3	HWOVP	Indication of over voltage protection in the past.	It operates at about 125% typ.(fixed) of rated.
4	OTP	Indication of over temperature protection in the past.	-
5	PFCLVP	Indication of voltage drop in the boost section.	It might be 1, when remote off due to the boost operation stopping.
7	INPUTLVP	-	Indication of the input voltage drop while remote on state. * ¹
8	RC OFF	Indication of remote off.	-
9-13	SYSTEM	Indication of internal error in the past.	Contact our support when an error occurs.
6, 14, 15	Reserved	Reserved	-

* INPUTLVP is not available for the firmware version 3.000 and 3.001.

Example : In case of "Remote off" after "Output over current".

bit 0 : SWOCP, bit 5 : PFCLVP, bit 8 : RC OFF is set. ⇒ Register value : 0x0121

To clear alarm history, perform the following operations.

- A. The Write clear request to [Clear Alarm History] register.
It will be cleared as soon as the query is received.
- B. "Remote on " after "Remote off"
- C. Shut-down of the input.
- D. Sleep mode (See Instruction Manual section 6-17)

The alarm history cannot be cleared when protection is continued.

Because the bit is set again.

*¹ INPUTLVP is set when the input voltage dropped in remote on state.

To distinguish the normal cutting off of the input voltage by the user and abnormal input voltage drop, please obey the following sequence:

First please remote off and then shut down the input.

2) Register Read

Request PDU

Field	Byte	Read Inputs.	
		Value	Value
Function code	1	0x04	0x04
Starting Address	2	0 (0x0000)	20 (0x0014)
Quantity of Registers	2	1 (0x0000)	1 (0x0000)

Response PDU

Field	Byte	Read Inputs.	
		Value	Value
Function code	1	0x04	0x04
Byte count	1	2 (2 x 1)	2 (2 x 1)
Registers value	2	Reading data.	Reading data.

Error PDU

Field	Byte	Read Inputs.
		Value
Function code	1	0x84
Exception code	1	0x02

2 **Register Name** Output Voltage

Data Type	Register Function	Starting Address	Qty	Non-volatile
Input	Monitor value of output voltage	1 (0x0001)	1	No

1) Register Details

This register is measurement value of output voltage. (Between “+ S” and “-S”)
Register value is normalized[Q10] signed data with rating.

Data Type	Measurement Range	Accuracy
Normalization [Q10]	0.2 ~ 1.4 [Q10]	+ / - 0.3% of the rating (Ta=25°C)
(Integer notation)	204 ~ 1433	-

※ The value out of measurement range is also returned, but measurement accuracy is not guaranteed.

The actual voltage value is calculated by the following formula.

$$\text{Output voltage [V]} = \text{Nominal Voltage} \times \text{Register value (Decimal)} \times 2^{-10}$$

• GXE output rating

Model	Nominal Voltage
GXE600-24	24 [V]
GXE600-48	48 [V]

Example : When the register reading value is “1000d” in GXE 600-24

$$\text{Output voltage} = 24 \times 1000 \times 2^{-10} = 23.4375 \text{ [V]}$$

2) Register Read

Request PDU		Read Inputs.
Field	Byte	Value
Function code	1	0x04
Starting Address	2	1 (0x0001)
Quantity of Registers	2	1 (0x0001)

Response PDU		Read Inputs.
Field	Byte	Value
Function code	1	0x04
Byte count	1	2 (2 x 1)
Registers value	2	Reading data.

Error PDU		Read Inputs.
Field	Byte	Value
Function code	1	0x84
Exception code	1	0x02

3 **Register Name** Output Current

Data Type	Register Function	Starting Address	Qty	Non-volatile
Input	Monitor value of output current	2 (0x0002)	1	No

1) Register Details

This register is measurement value of output current.

Register value is normalized[Q10] signed data with rating.

Data Type	Measurement Range	Accuracy
Normalization [Q10]	-0.01 ~ 1.3 [Q10]	+ / - 1.0% of the rating (Ta=25°C)
(Integer notation)	-102 ~ 1331	-

※ The value out of measurement range is also returned, but measurement accuracy is not guaranteed.

The actual current value is calculated by the following formula.

$$\text{Output current [A]} = \text{Maximum Current} \times \text{Register value (Decimal)} \times 2^{-10}$$

• GXE output rating

Model	Maximum Current
GXE600-24	25 [A]
GXE600-48	12.5 [A]

Example : When the register reading value is "1000d" in GXE 600-48

$$\text{Output current} = 12.5 \times 1000 \times 2^{-10} = 12.207 \text{ [A]}$$

2) Register Read

Request PDU		Read Inputs.
Field	Byte	Value
Function code	1	0x04
Starting Address	2	2 (0x0002)
Quantity of Registers	2	1 (0x0001)

Response PDU		Read Inputs.
Field	Byte	Value
Function code	1	0x04
Byte count	1	2 (2 x 1)
Registers value	2	Reading data.

Error PDU		Read Inputs.
Field	Byte	Value
Function code	1	0x84
Exception code	1	0x02

4 **Register Name** Internal Temperature

Data Type	Register Function	Starting Address	Qty	Non-volatile
Input	Monitor value of device temperature[°C].	3 (0x0003)	1	No

1) Register Details

This register is the value of the temperature sensor inside the power supply.

Register value is signed 16-bit integer data value (unit : °C).

Data Type	Measurement Range	Accuracy
Integer notation	-20 ~ 100 [°C]	+ / - 5 °C *

※ The value out of measurement range is also returned, but measurement accuracy is not guaranteed.

* Accuracy is the difference between the measurement point and the actual temperature.

Register value is the power supply internal temperature, which is different from the power supply ambient temperature.

The register shows a value higher than the ambient temperature of the power supply.

Because there is a temperature measuring point inside the power supply, it receives heat from the power supply part.

The GXE series is for convection cooling products.

The measurement temperature is affected by the installation direction.

The temperature measurement points are as follows.

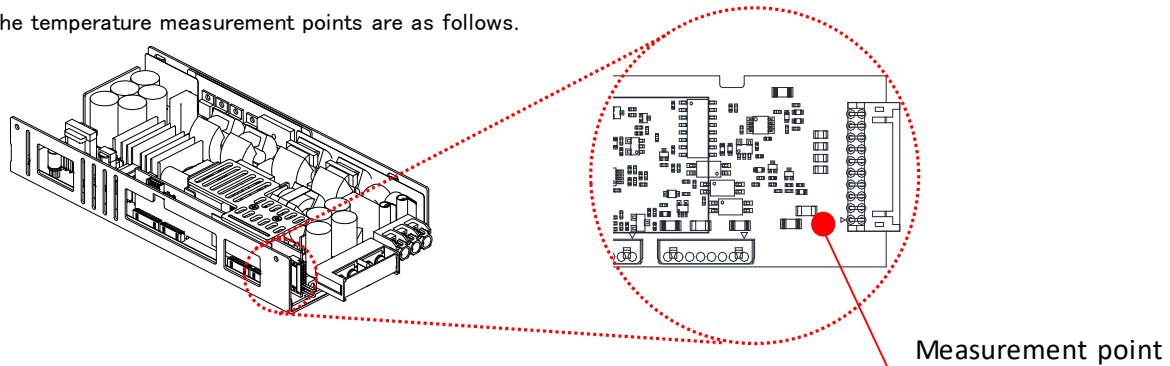

2) Register Read

Request PDU		Read Inputs.
Field	Byte	Value
Function code	1	0x04
Starting Address	2	3 (0x0003)
Quantity of Registers	2	1 (0x0001)

Response PDU		Read Inputs.
Field	Byte	Value
Function code	1	0x04
Byte count	1	2 (2 x 1)
Registers value	2	Reading data.

Error PDU		Read Inputs.
Field	Byte	Value
Function code	1	0x84
Exception code	1	0x02

5 **Register Name** Operation Time

Data Type	Register Function	Starting Address	Qty	Non-volatile
Input	Monitor value of cumulative operating time	4 (0x0004)	2	Yes

1) Register Details

This register is the value of the cumulative operating time.

Operation time is incremented every second while power is being output.

Register value is signed 32-bit integer data value (unit : Second).

Cumulative operating time is retained even when input is cut off.

Data Type	Measurement Range	Accuracy
Integer notation (32bit)	Over 20 years	± 2 % *

* If the power output is less than 1 second, it will not be added to the cumulative operating time.

Because measurement resolution is 1 second.

Example : Response PDU when cumulative operating time is "19088743" seconds (About 221 days)

19088743d = 0x01234567

FC	Bytes	D0	D1	D2	D3
0x04	0x04	0x01	0x23	0x45	0x67

2) Register Read

Request PDU		Read Inputs.
Field	Byte	Value
Function code	1	0x04
Starting Address	2	4 (0x0004)
Quantity of Registers	2	2 (0x0002)

Response PDU		Read Inputs.
Field	Byte	Value
Function code	1	0x04
Byte count	1	4 (2 x 2)
Registers value	4	Reading data.

Error PDU		Read Inputs.
Field	Byte	Value
Function code	1	0x84
Exception code	1	0x02/0x04

6 Register Name E-cap L0 Remaining

Data Type	Register Function	Starting Address	Qty	Non-volatile
Input	Remaining lifetime of the electrolytic capacitor	6 (0x0006)	1	Yes

1) Register Details

It is a function to predict remaining lifetime of the electrolytic capacitor.

This is a method of subtracting the "Lo" value of the electrolytic capacitor taking into consideration the "input / output condition" and "ambient temperature".

GXE has "Lo" remaining lifetime prediction value at rated upper temperature of electrolytic capacitor.

This register returns the smallest value of predicted "Lo" remaining lifetime.

Register value is signed 16-bit integer data value (unit : hour).

"Lo" value of the electrolytic capacitor decreases from the initial value.

It means that the expected lifetime of electrolytic capacitor has been reached when the "Lo" value becomes "0".

"Lo" value is subtracted even after it becomes "0", and saturates at the lower limit of the measurement range.

"Lo" value is retained even when input is cut off.

"Lo" predicted value is not updated in sleep mode.

This function assumes "Mount A" in the device mounting direction.

"Lo" value is just reference data, not guaranteed.

Data Type	Measurement Range	Initial Value *1	Accuracy
Integer notation (16bit)	-10000 ~ 12000	24V model : 8000	± 30% of Electrolytic Capacitor Lifetime *2
		48V model : 10000	

*1 Since the electrolytic capacitors used are different, the initial value is also different for each voltage model.

*2 Electrolytic Capacitor Lifetime

It is the time period to use up the "Lo" of electrolytic capacitor.

The rate of decrease of Lo depends on the usage environment of the power supply.

Refer to "Reliability data" and confirm the electrolytic capacitor expected life time.

Assuming that the temperature of the electrolytic capacitor (Tc) is constant, the remaining life is calculated by the following formula.

$$\text{Remaining Life[hour]} = \text{Register value} * 2^{\frac{105-Tc}{10}}$$

Example : Electrolytic capacitor temperature Tc = 50 °C, remaining life register value = 200

$$\text{Remaining Life[hour]} = 200 * 2^{\frac{105-50}{10}} \approx 9051[h]$$

- Caution -

Even if the value of prediction "Lo" is a positive value, it does not guarantee that GXE will not fail or abnormality will not occur. When the ambient temperature is low, it is conceivable that the predicted reduction rate of the "Lo" value drops remarkably. However, even if the "Lo" value remains, it is recommended to exchange at 15 years after delivery.

It is because deterioration of the sealing rubber of the electrolytic capacitor is considered.

2) Register Read

<u>Request PDU</u>			Read Inputs.
Field	Byte	Value	
Function code	1	0x04	
Starting Address	2	6 (0x0006)	
Quantity of Registers	2	1 (0x0001)	

<u>Response PDU</u>			Read Inputs.
Field	Byte	Value	
Function code	1	0x04	
Byte count	1	2 (2 x 1)	
Registers value	2	Reading data.	

<u>Error PDU</u>			Read Inputs.
Field	Byte	Value	
Function code	1	0x84	
Exception code	1	0x02	

7 **Register Name** Analog CV Reference

Data Type	Register Function	Starting Address	Qty	Non-volatile
Input	Monitor value of analog PV terminal voltage	7 (0x0007)	1	No

* This register is not available for the firmware version 3.000 and 3.001.

1) Register Details

This register has a measurement value of analog PV terminal voltage.

Register value is normalized[Q10] signed data with rating.

Data Type	Measurement Range	Accuracy
Normalization [Q10]	0.1 ~ 1.4 [Q10]	+ / - 0.5% of the rating (Ta=25°C)
(Integer notation)	102 ~ 1433	-

※ The value out of measurement range is also returned, but measurement accuracy is not guaranteed.

The actual voltage value is calculated by the following formula.

$$\text{Output voltage [V]} = \text{Nominal Voltage} \times \text{Register value (Decimal)} \times 2^{-10}$$

• GXE output rating

Model	Nominal Voltage
GXE600-24	24 [V]
GXE600-48	48 [V]

Example : When the register reading value is "1000d" in GXE 600-24

$$\text{Output voltage} = 24 \times 1000 \times 2^{-10} = 23.4375 \text{ [V]}$$

2) Register Read

Request PDU		Read Inputs.
Field	Byte	Value
Function code	1	0x04
Starting Address	2	7 (0x0007)
Quantity of Registers	2	1 (0x0001)

Response PDU		Read Inputs.
Field	Byte	Value
Function code	1	0x04
Byte count	1	2 (2 x 1)
Registers value	2	Reading data.

Error PDU		Read Inputs.
Field	Byte	Value
Function code	1	0x84
Exception Code	1	0x02

8 **Register Name** Analog CC Reference

Data Type	Register Function	Starting Address	Qty	Non-volatile
Input	Monitor value of analog CC terminal current	8 (0x0008)	1	No

* This register is not available for the firmware version 3.000 and 3.001.

1) Register Details

This register has a measurement value of analog CC terminal current.

Register value is normalized[Q10] signed data with rating.

Data Type	Measurement Range	Accuracy
Normalization [Q10]	0.1 ~ 1.4 [Q10]	+ / - 0.5% of the rating (Ta=25°C)
(Integer notation)	102 ~ 1433	-

※ The value out of measurement range is also returned, but measurement accuracy is not guaranteed.

The actual current value is calculated by the following formula.

$$\text{Output current [A]} = \text{Maximum Current} \times \text{Register value (Decimal)} \times 2^{-10}$$

• GXE output rating

Model	Maximum Current
GXE600-24	25 [A]
GXE600-48	12.5 [A]

Example : When the register reading value is "1000d" in GXE 600-48

$$\text{Output current} = 12.5 \times 1000 \times 2^{-10} = 12.207 \text{ [A]}$$

2) Register Read

Request PDU		Read Inputs.
Field	Byte	Value
Function code	1	0x04
Starting Address	2	8 (0x0008)
Quantity of Registers	2	1 (0x0001)

Response PDU		Read Inputs.
Field	Byte	Value
Function code	1	0x04
Byte count	1	2 (2 x 1)
Registers value	2	Reading data.

Error PDU		Read Inputs.
Field	Byte	Value
Function code	1	0x84
Exception code	1	0x02

9 **Register Name** PF Output Time

Data Type	Register Function	Starting Address	Qty	Non-volatile
Input	Monitor value of PF signal output time	9 (0x0009)	1	No

* This register is not available for the firmware version 3.000 and 3.001.

1) Register Details

This register has a value of the cumulative time while PF signal is out.
 Register value is signed 16-bit integer data value (unit: ms).
 The cumulative value will saturate at 10000.

To clear this register, perform the following operations.

- A. The Write clear request to [Clear PF Output Time] register.
- B. Shut-down of the input.
- C. Sleep mode (See Instruction Manual section 6-17)

•Use case

By setting below conditions, you can know if there was the output voltage drop due to the CC mode behavior caused by over load while CV mode use.

- CC reference < OCP threshold
- PF mode: CVPF

* Please clear this register before using this function.
 Because it can have some value due to the output voltage drop caused by remote off.

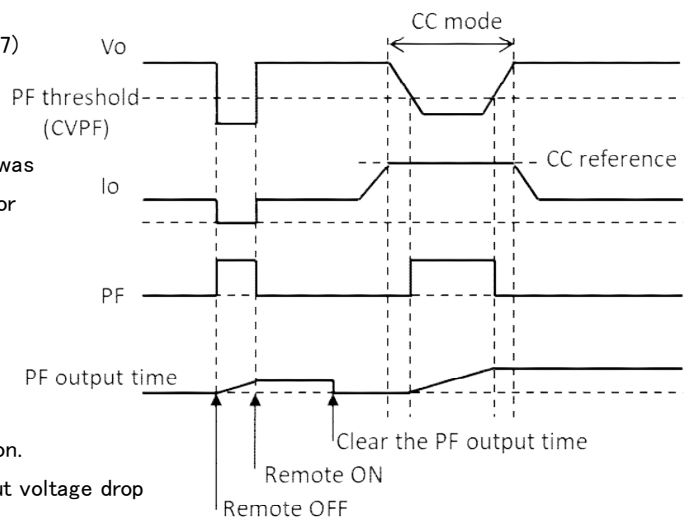

Data Type	Measurement Range	Resolution
Integer notation	0 ~ 10000 [ms]	1 [ms]

2) Register Read

<u>Request PDU</u>			Read Inputs.
Field	Byte	Value	
Function code	1	0x04	
Starting Address	2	f	
Quantity of Registers	2	1 (0x0001)	

<u>Response PDU</u>			Read Inputs.
Field	Byte	Value	
Function code	1	0x04	
Byte count	1	2 (2 x 1)	
Registers value	2	Reading data.	

<u>Error PDU</u>			Read Inputs.
Field	Byte	Value	
Function code	1	0x84	
Exception Code	1	0x02	

11 **Register Name Alarm History (Non-Volatile)**

Data Type	Register Function	Starting Address	Qty	Non-volatile
Input	Alarm history indicator	21 (0x0015)	1	Yes

* This register is not available for the firmware version 3.000 and 3.001.

1) Register Details

This register is same as [Alarm History (Volatile)] but this can hold the data after cutting off the input voltage.

"Alarm history" data is in bitmap format.

"1" is set when corresponding bit protection operation is occurred.

The protection assigned to each bit is shown in the table below.

Bit	Name	Description	Remarks
0	SWOCP	Indication of over current protection in the past.	It is possible to change the threshold.
1	HWOCP	Indication of over current protection in the past.	"HWOCP" responds faster than "SWOCP" and the threshold is far.
2	SWOVP	Indication of over voltage protection in the past.	It is possible to change the threshold.
3	HWOVP	Indication of over voltage protection in the past.	It operates at about 125% typ.(fixed) of rated.
4	OTP	Indication of over temperature protection in the past.	-
5	PFCLVP	Indication of voltage drop in the boost section	It might be 1, when remote off due to the boost operation stopping.
7	INPUTLVP	-	Indication of the input voltage drop while remote on state. *
8	RC OFF	Indication of remote off.	-
9-13	SYSTEM	Indication of internal error in the past.	Contact our support when an error occurs.
6, 14, 15	Reserved	Reserved	-

You can only clear this register by writing clear request to [Clear Alarm History] register.

The alarm history cannot be cleared when protection is continued.

Because the bit is set again.

* Please refer to the [Alarm History (Volatile)] register about how to use the INPUTLVP.

- Caution -

- Since this register has an indefinite value at the first startup, it is recommended to use it after cleaning the history.
- Note that if the CNT terminal is used for remote control and the filter sensitivity is set higher than the default value (10 [ms]), the "RC OFF" bit may be set when the input is re-input.

2) Register Read

<u>Request PDU</u>			Read Inputs.
Field	Byte	Value	
Function code	1	0x04	
Starting Address	2	21 (0x0015)	
Quantity of Registers	2	1 (0x0000)	

<u>Response PDU</u>			Read Inputs.
Field	Byte	Value	
Function code	1	0x04	
Byte count	1	2 (2 x 1)	
Registers value	2	Reading data.	

<u>Error PDU</u>			Read Inputs.
Field	Byte	Value	
Function code	1	0x84	
Exception code	1	0x02	

12 **Register Name Model Name**

Data Type	Register Function	Starting Address	Qty	Non-volatile
Input	Strings of device model name. [ASCII]	500 (0x01F4)	15	Yes

1) Register Details

This register is the product model name registered in GXE, and it is written in ASCII.

Handle register data as character array of 8 bit data x 30.

Valid as "Product model name" is data from the beginning to the terminating character [NULL 0x00].

Product model name is retained even when input is cut off.

Example : Model name is "GXE600-24".

Request PDU

FC	Start Address	Quantity
0x04	0x01 0xF4	0x00 0x0F

Response PDU

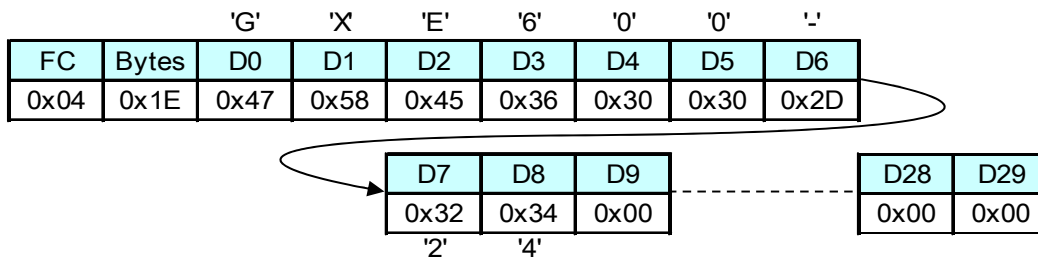

9 bytes of D 0 to D 8 are valid as character string data in the data bytes.

2) Register Read

Request PDU

Read Inputs.

Field	Byte	Value
Function code	1	0x04
Starting Address	2	500 (0x01F4)
Quantity of Registers	2	15 (0x000F)

Response PDU

Read Inputs.

Field	Byte	Value
Function code	1	0x04
Byte count	1	30 (2 x 15)
Registers value	30	Reading data.

Error PDU

Read Inputs.

Field	Byte	Value
Function code	1	0x84
Exception code	1	0x02/0x04

13 **Register Name** Serial No.

Data Type	Register Function	Starting Address	Qty	Non-volatile
Input	Strings of device serial number. [ASCII]	520 (0x0208)	8	Yes

1) Register Details

This register is the serial number registered in GXE, and it is written in ASCII.

Handle register data as character array of 8 bit data x 16.

Valid as "Serial number" is data from the beginning to the terminating character [NULL 0x00].

Serial number is retained even when input is cut off.

2) Register Read

Request PDU

Read Inputs.

Field	Byte	Value
Function code	1	0x04
Starting Address	2	520 (0x0208)
Quantity of Registers	2	8 (0x0008)

Response PDU

Read Inputs.

Field	Byte	Value
Function code	1	0x04
Byte count	1	16 (2 x 8)
Registers value	16	Reading data.

Error PDU

Read Inputs.

Field	Byte	Value
Function code	1	0x84
Exception code	1	0x02/0x04

14 **Register Name** Lot No.

Data Type	Register Function	Starting Address	Qty	Non-volatile
Input	Strings of device lot number. [ASCII]	540 (0x021C)	8	Yes

1) Register Details

This register is the lot number registered in GXE, and it is written in ASCII.

Handle register data as character array of 8 bit data x 16.

Valid as "Lot number" is data from the beginning to the terminating character [NULL 0x00].

Lot number is retained even when input is cut off.

2) Register Read

Request PDU

Read Inputs.

Field	Byte	Value
Function code	1	0x04
Starting Address	2	540 (0x021C)
Quantity of Registers	2	8 (0x0008)

Response PDU

Read Inputs.

Field	Byte	Value
Function code	1	0x04
Byte count	1	16 (2 x 8)
Registers value	16	Reading data.

Error PDU

Read Inputs.

Field	Byte	Value
Function code	1	0x84
Exception code	1	0x02/0x04

15 Register Name Firmware Ver.

Data Type	Register Function	Starting Address	Qty	Non-volatile
Input	Indication of the Firmware version.	1000 (0x03E8)	1	Yes

1) Register Details

This register is 4-digit BCD (Binary coded Decimal) data of 16 bits and corresponds to the version number of the power supply installed firmware.

The upper 1 digit indicates the integer part, and the lower 3 digits indicate the decimal part.

Firmware version is retained even when input is cut off.

Example

FW Version	Value
1.001	0x1001
2.054	0x2054

2) Register Read

Request PDU

Read Inputs.

Field	Byte	Value
Function code	1	0x04
Starting Address	2	1000 (0x03E8)
Quantity of Registers	2	1 (0x0001)

Response PDU

Read Inputs.

Field	Byte	Value
Function code	1	0x04
Byte count	1	2 (2 x 1)
Registers value	2	Reading data.

Error PDU

Read Inputs.

Field	Byte	Value
Function code	1	0x84
Exception code	1	0x02

4.4 Holding register details

In this chapter, Details on the functions of the Holding registers defined in GXE.

- Explanatory notes

Attributes assigned to registers

Address allocated to register

Number of words allocated to register

It is indicated the supported non-volatile, whether data is retained even after input shutdown

Yes : Data is retained even after input is shut down.

No : Data is deleted after input is shut down.

Details of the register function

Packet frame configuration at register access

Packet frame configuration at register write

3	Register Name	PVCC ReferenceConfiguration		
Data Type	Register Function	Starting Address	Qty	Non-volatile
Holding	Selection of analog or digital reference value	101 (0x0065)	1	Yes

1) Register Details

This register is the setting register related to the output reference value. GXE has two output reference, which are PV / CC terminal reference (Analog PV / CC) and PV / CC communication reference (Digital PV / CC). Output reference can be selected with this register. Configuration data is retained even when input is cut off.

• Register configuration value

Bit	Function	Digital PV/CC	Analog PV/CC	Factory setting
0	Selection of output voltage reference	1	0	0
1	Selection of output current reference	1	0	0
2 - 15	Reserved	-	-	0

* Write '0' to the reserved bit. Writing '1' is ignored.

Digital PV / CC is not referenced when analog PV / CC is selected.
 Conversely, Analog PV / CC is not referenced when Digital PV / CC is selected.

This register is just a function to select the input source of the PV / CC reference value.
 Change input source according to setting of this register, when changing PV / CC reference value.
 Refer to the instruction manual, for Analog PV / CC.

2) Register Read

Request PDU

Field	Byte	Read Holdings.
Function code	1	0x03
Starting Address	2	101 (0x0065)
Quantity of Registers	2	(0x0000)

Response PDU

Field	Byte	Read Holdings.
Function code	1	0x03
Byte count	1	2 (2 x 1)
Registers value	2	Reading data.

Error PDU

Field	Byte	Read Holdings.
Function code	1	0x83
Exception code	1	0x02 / 0x04

3) Register Write

Request PDU

Field	Byte	Write Holding.
Function code	1	0x06
Starting Address	2	101 (0x0065)
Registers value	2	writing data.

Response PDU

Field	Byte	Write Holding.
Function code	1	0x06
Starting Address	2	101 (0x0065)
Register value	2	echo query data.

Error PDU

Field	Byte	Write Holding.
Function code	1	0x86
Exception code	1	0x02 / 0x03 / 0x04

The packet frame described on each page is an example of access to one register. Multiple access is possible when the register address assignment is continuous.

1 **Register Name Remote On/Off**

Data Type	Register Function	Starting Address	Qty	Non-volatile
Holding	Remote On/Off (Volatile)	0 (0x0000)	1	No
Holding	Remote On/Off (Non-Volatile)	5 (0x0005)	1	Yes

1) Register Details

This register manipulates the remote control signal via communication.

It is possible to remotely control the output of the GXE by writing the reference value to the register.

Prior to operation, it is necessary to set [Remote Control Configuration] register to enable setting of remote control signal via communication. There are two remote ON / OFF registers, but only the registers set with [Remote Control Configuration] register are referenced.

•Register setting value

Value	Function
0 (0x0000)	Remote Off
1 (0x0001)	Remote On

* If an unspecified value is written, only the lowest bit is accepted as a valid value.

•Remote on / off registers have volatile and nonvolatile registers.

Register	Description	AC input	Factory setting
Remote On/Off (Volatile)	GXE will start from the default value each time AC input. Because the register value is "Volatile".	0 : Remote Off	-
Remote On/Off (Non-Volatile)	GXE follows the previously set remote on / off signal. Because the register value is "Non-Volatile".	(Previously set)	0 : Remote Off

These registers behave differently when brownout occurs for a certain time or more.

The figure below shows the operation image.

The Remote On / Off (Volatile) signal starts from "Remote Off" state even after brownout occurs.

On the other hand, Remote On / Off signal (Non-Volatile) maintains the "Remote On" state even after brownout occurs.

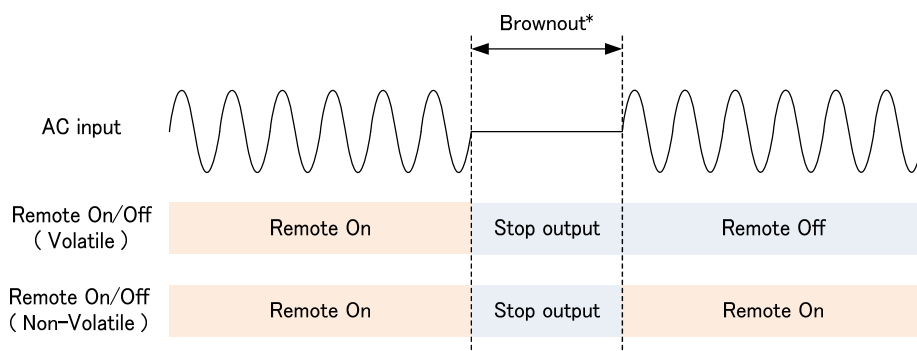

* Whether " Remote On/Off (Volatile) " volatilizes or not depends on the degree of brownout.

- Caution -

The remote control signal is not referred for depending on the setting of [Remote Control Configuration] register.

However, Register value can be changed regardless of whether or not the [Remote On / Off] register is referred.

GXE performs the output operation based on the current register value.

In some cases, output of GXE may be started just by changing the [Remote Control Configuration] register.

2) Register Read

Request PDU		Read Holdings.	
Field	Byte	Value	Value
Function code	1	0x03	0x03
Starting Address	2	0 (0x0000)	5 (0x0005)
Quantity of Registers	2	1 (0x0001)	1 (0x0001)

Response PDU		Read Holdings.	
Field	Byte	Value	Value
Function code	1	0x03	0x03
Byte count	1	2 (2 x 1)	2 (2 x 1)
Registers value	2	Reading data.	Reading data.

Error PDU		Read Holdings.	
Field	Byte	Value	Value
Function code	1	0x83	0x83
Exception code	1	0x02 / 0x04	0x02 / 0x04

3) Register Write

Request PDU		Write Holding.	
Field	Byte	Value	Value
Function code	1	0x06	0x06
Starting Address	2	0 (0x0000)	5 (0x0005)
Registers value	2	writing data.	writing data.

Response PDU		Write Holding.	
Field	Byte	Value	Value
Function code	1	0x06	0x06
Starting Address	2	0 (0x0000)	5 (0x0005)
Register value	2	echo query data.	echo query data.

Error PDU		Write Holding.	
Field	Byte	Value	Value
Function code	1	0x86	0x86
Exception code	1	0x02 / 0x03 / 0x04	0x02 / 0x03 / 0x04

2 **Register Name Remote Control Configuration**

Data Type	Register Function	Starting Address	Qty	Non-volatile
Holding	Remote On/Off control configuration	100 (0x0064)	1	Yes

1) Register Details

This is the configuration register for remote On/Off control .

It is possible to change remote on/off control mode and input sensitivity of the remote on/off control terminal input.

Configuration data is retained even when input is cut off.

•Register configuration value

Byte	Function	Max	Min	Factory setting
LSB	Remote control mode	4	0	0
MSB	Terminal input sensitivity	100	0	10

*An exception response (Exception code: 0x03) is returned when writing values outside the range.

•Remote control mode

Two remote control signals for GXE are available: the remote control terminal input of CN84 and the communication input.

Select one suitable for system.

Value	Description
0 (Factory setting)	Terminal input is used as remote control signal. Communication input is not referenced. Refer to the instruction manual for details of remote on/off control using terminal input.
1	Remote On/Off (Volatile) is used as remote control signal. Remote On/Off (Non-Volatile) and Terminal input are not referenced.
2	Remote On/Off (Non-Volatile) is used as remote control signal. Remote On/Off (Volatile) and Terminal input are not referenced.
3	The logical AND of the Terminal input and the Remote On/Off (Volatile) is used as the remote control signal. Remote On/Off (Non-Volatile) is not referenced.
4	The logical AND of the Terminal input and the Remote On/Off (Non-Volatile) is used as the remote control signal. Remote On/Off (Volatile) is not referenced.

The following table shows the relationship between remote control signal and GXE output in each remote control mode.

Remote control mode			Terminal input (ON-Active)	Communication		Output
Value	Terminal input	Communication		Volatile	Non-Volatile	
0 (Factory setting)	Enable	Disable	OFF	x	x	OFF
			ON	x	x	ON
1	Disable	Enable (Volatile)	x	OFF	x	OFF
			x	ON	x	ON
2	Disable	Enable (Non-Volatile)	x	x	OFF	OFF
			x	x	ON	ON
3	Enable	Enable (Volatile)	OFF	OFF	x	OFF
				ON	x	
			ON	ON	x	ON
4	Enable	Enable (Non-Volatile)	OFF	x	OFF	OFF
				x	ON	
			ON	x	OFF	ON
				x	ON	

x : It is not referred.

•Terminal input sensitivity

GXE has bounce removal function.

Bounce (chattering) may occur in the signal due to the connection circuit form of the terminal input, but it can be removed by this function.

The severity of bounce removal can be adjusted with "Terminal input sensitivity".

•Register configuration value

Data Type	Max	Min	Factory setting	Unit
Integer notation	100	0	10	ms

Larger bounces can be removed by increasing the number, but the response to the terminal input will be delayed by that much.

Changing from the factory setting is unnecessary unless a large mechanical relay or the like is used.

2) Register Read

Request PDU

Field	Byte	Read Holdings. Value
Function code	1	0x03
Starting Address	2	100 (0x0064)
Quantity of Registers	2	1 (0x0001)

Response PDU

Field	Byte	Read Holdings. Value
Function code	1	0x03
Byte count	1	2 (2 x 1)
Registers value	2	Reading data.

Error PDU

Field	Byte	Read Holdings. Value
Function code	1	0x83
Exception code	1	0x02 / 0x04

3) Register Write

<u>Request PDU</u>		
Field	Byte	Write Holding. Value
Function code	1	0x06
Starting Address	2	100 (0x0064)
Registers value	2	writing data.

<u>Response PDU</u>		
Field	Byte	Write Holding. Value
Function code	1	0x06
Starting Address	2	100 (0x0064)
Register value	2	echo query data.

<u>Error PDU</u>		
Field	Byte	Write Holding. Value
Function code	1	0x86
Exception code	1	0x02 / 0x03 / 0x04

3 **Register Name** CVCC Reference Configuration

Data Type	Register Function	Starting Address	Qty	Non-volatile
Holding	Selection of analog or digital reference value	101 (0x0065)	1	Yes

1) Register Details

This register is the setting register related to the output reference value. GXE has two output reference, which are PV / CC terminal reference (Analog CV / CC) and CV / CC communication reference (Digital CV / CC). Output reference can be selected with this register.
Configuration data is retained even when input is cut off.

•Register configuration value

Bit	Function	Digital CV/CC	Analog CV/CC	Factory setting
0	Selection of output voltage reference	1	0	0
1	Selection of output current reference	1	0	0
2 – 15	Reserved	–	–	0

* Write '0' to the reserved bit. Writing '1' is ignored.

Digital CV / CC is not referenced when analog CV / CC is selected.
On the contrary, Analog CV / CC is not referenced when Digital CV / CC is selected.

This register is just a function to select the input source of the CV / CC reference value.
Change input source according to setting of this register, when changing CV / CC reference value.
Refer to the instruction manual, for Analog CV / CC.

2) Register Read

Request PDU		Read Holdings.
Field	Byte	Value
Function code	1	0x03
Starting Address	2	101 (0x0065)
Quantity of Registers	2	(0x0000)

Response PDU		Read Holdings.
Field	Byte	Value
Function code	1	0x03
Byte count	1	2 (2 x 1)
Registers value	2	Reading data.

Error PDU		Read Holdings.
Field	Byte	Value
Function code	1	0x83
Exception code	1	0x02 / 0x04

3) Register Write

<u>Request PDU</u>		
Field	Byte	Write Holding. Value
Function code	1	0x06
Starting Address	2	101 (0x0065)
Registers value	2	writing data.

<u>Response PDU</u>		
Field	Byte	Write Holding. Value
Function code	1	0x06
Starting Address	2	101 (0x0065)
Register value	2	echo query data.

<u>Error PDU</u>		
Field	Byte	Write Holding. Value
Function code	1	0x86
Exception code	1	0x02 / 0x03 / 0x04

4 **Register Name Protect Configuration**

Data Type	Register Function	Starting Address	Qty	Non-volatile
Holding	Configure protection mode	102 (0x0066)	1	Yes

1) Register Details

This is a register that performs GXE operation configuration after exceeding the protection threshold. GXE can select latch stop and auto recovery as operation when the protection threshold is exceeded. Select one suitable for system. Configuration data is retained even when input is cut off.

•Register configuration value

Bit	Name	Setting Change	Factory setting
0	SWOCP	Possible	Auto recovery
1	HWOCP	Impossible	Latch stop
2	SWOVP	Possible	Latch stop
3	HWOVP	Possible	Latch stop
4	OTP	Impossible	Latch stop
5	PFCLVP	Impossible	Auto recovery
6, 7	Reserved	Impossible	-
8	RC OFF	Impossible	-
9-13	SYSTEM	Impossible	Latch stop
14, 15	Reserved	Impossible	-

*Write "0" to the bit for which setting change is impossible. Writing '1' is ignored.

Refer the description of the [Protection operation history] register for details on the protection.

•How to set each bit

Select the latch stop and auto recovery by writing the following values to each bit.

Value	Function
0	Set the protection action when the protection threshold is exceeded to "Auto recovery"
1	Set the protection action when the protection threshold is exceeded to "Latch stop"

Protection set to "Auto recovery" will release protection after the time set in the [Auto Recovery Time] register. The output of GXE is resumed when the cause of the protection function has been resolved.

Release of the latch stop condition is performed by the following operation.

- A. Apply input voltage after input is cut off.
Set at least 3 minutes interval from disconnection to reconnection.
- B. Remote on after remote off
The latch is released when GXE output resumes.

2) Register Read

<u>Request PDU</u>			Read Holdings.
Field	Byte	Value	
Function code	1	0x03	
Starting Address	2	102 (0x0066)	
Quantity of Registers	2	(0x0000)	

<u>Response PDU</u>			Read Holdings.
Field	Byte	Value	
Function code	1	0x03	
Byte count	1	2 (2 x 1)	
Registers value	2	Reading data.	

<u>Error PDU</u>			Read Holdings.
Field	Byte	Value	
Function code	1	0x83	
Exception code	1	0x02 / 0x04	

3) Register Write

<u>Request PDU</u>			Write Holding.
Field	Byte	Value	
Function code	1	0x06	
Starting Address	2	102 (0x0066)	
Registers value	2	writing data.	

<u>Response PDU</u>			Write Holding.
Field	Byte	Value	
Function code	1	0x06	
Starting Address	2	102 (0x0066)	
Register value	2	echo query data.	

<u>Error PDU</u>			Write Holding.
Field	Byte	Value	
Function code	1	0x86	
Exception code	1	0x02 / 0x03 / 0x04	

5 **Register Name** Digital CV Reference

Data Type	Register Function	Starting Address	Qty	Non-volatile
Holding	Digital reference value of output voltage	103 (0x0067)	1	Yes

1) Register Details

This register sets the output voltage reference value (Digital CV).

The reference value is handled as Q10 format data normalized by the nominal voltage.

Digital CV is not referenced when analog CV is selected.

Configuration data is retained even when input is cut off.

•Register value

Data Type	Max	Min	Factory setting	Unit	Accuracy with respect to nominal output voltage
Normalization [Q10]	1.3	0	1.0	-	+ / - 1.0 % (Ta=25°C)
(Integer notation)	1331	0	1024	-	-

*An exception response (Exception code: 0x03) is returned when writing values outside the range.

The specification range of the CV reference value is 0.2 – 1.2 .

This register can also input out of range. However, the protection function may operate.

The CV reference change is influenced by the slew rate setting register, not the step change.

Slew rate setting register : [CV Rising Time], [CV Transition Time]

The output voltage may not follow the CV reference because it is affected by the load impedance.

2) Register Read

Request PDU

Field	Byte	Value	Read Holdings.
Function code	1	0x03	
Starting Address	2	103 (0x0067)	
Quantity of Registers	2	1 (0x0001)	

Response PDU

Field	Byte	Value	Read Holdings.
Function code	1	0x03	
Byte count	1	2 (2 x 1)	
Registers value	2	Reading data.	

Error PDU

Field	Byte	Value	Read Holdings.
Function code	1	0x83	
Exception code	1	0x02 / 0x04	

3) Register Write

<u>Request PDU</u>			Write Holding.
Field	Byte	Value	
Function code	1	0x06	
Starting Address	2	103 (0x0067)	
Registers value	2	writing data.	

<u>Response PDU</u>			Write Holding.
Field	Byte	Value	
Function code	1	0x06	
Starting Address	2	103 (0x0067)	
Register value	2	echo query data.	

<u>Error PDU</u>			Write Holding.
Field	Byte	Value	
Function code	1	0x86	
Exception code	1	0x02 / 0x03 / 0x04	

6 **Register Name** Digital CC Reference

Data Type	Register Function	Starting Address	Qty	Non-volatile
Holding	Digital reference value of output current	104 (0x0068)	1	Yes

1) Register Details

This register sets the output current reference value (Digital CC).

The reference value is handled as Q10 format data normalized by the maximum current.

Digital CC is not referenced when analog CC is selected.

Configuration data is retained even when input is cut off.

•Register value

Data Type	Max	Min	Factory setting	Unit	Accuracy with respect to maximum output current
Normalization [Q10]	1.15	0	1.15	-	+ / - 1.0 % (Ta=25°C)
(Integer notation)	1177	0	1177	-	-

*An exception response (Exception code: 0x03) is returned when writing values outside the range.

The specification range of the CC reference value is 0.2 – 1.15 .

This register can also input out of range. However, the current ripple may increase.

Refer to the instruction manual for setting CC reference value.

The CC reference change is influenced by the slew rate setting register, not the step change.

Slew rate setting register : [CC Rising Time], [CC Transition Time]

The output voltage may not follow the CC reference because it is affected by the load impedance.

2) Register Read

Request PDU

Field	Byte	Value	Read Holdings.
Function code	1	0x03	
Starting Address	2	104 (0x0068)	
Quantity of Registers	2	1 (0x0001)	

Response PDU

Field	Byte	Value	Read Holdings.
Function code	1	0x03	
Byte count	1	2 (2 x 1)	
Registers value	2	Reading data.	

Error PDU

Field	Byte	Value	Read Holdings.
Function code	1	0x83	
Exception code	1	0x02 / 0x04	

3) Register Write

<u>Request PDU</u>			Write Holding.
Field	Byte	Value	
Function code	1	0x06	
Starting Address	2	104 (0x0068)	
Registers value	2	writing data.	

<u>Response PDU</u>			Write Holding.
Field	Byte	Value	
Function code	1	0x06	
Starting Address	2	104 (0x0068)	
Register value	2	echo query data.	

<u>Error PDU</u>			Write Holding.
Field	Byte	Value	
Function code	1	0x86	
Exception code	1	0x02 / 0x03 / 0x04	

7 **Register Name** Over Voltage Threshold

Data Type	Register Function	Starting Address	Qty	Non-volatile
Holding	Threshold value of output over voltage.	105 (0x0069)	1	Yes

1) Register Details

This register sets the threshold value of output overvoltage.

The threshold value is handled as Q10 format data normalized by the nominal voltage.

Configuration data is retained even when input is cut off.

•Register value

Data Type	Max	Min	Factory setting	Unit	Accuracy
Normalization [Q10]	1.25*	0.2	1.25*	-	+ / - 3.0 % (Ta=25°C)
(Integer notation)	1280	204	1280	-	-

*An exception response (Exception code: 0x03) is returned when writing values outside the range.

*This accuracy mean that with respect to the nominal output voltage, the ratio of difference between the detection threshold set value and the power supply output voltage at protection operation.

Pay attention to the magnitude relation with the CV reference value.

The behavior of GXE may change.

CV reference < Over voltage threshold :

In constant current operation, the load resistance increases, and when the output voltage reaches the CV reference value, constant voltage operation is performed.

Over voltage threshold ≤ CV reference :

In constant current operation, the load resistance increases, and when the output voltage reaches the over voltage threshold, the output is shut down.

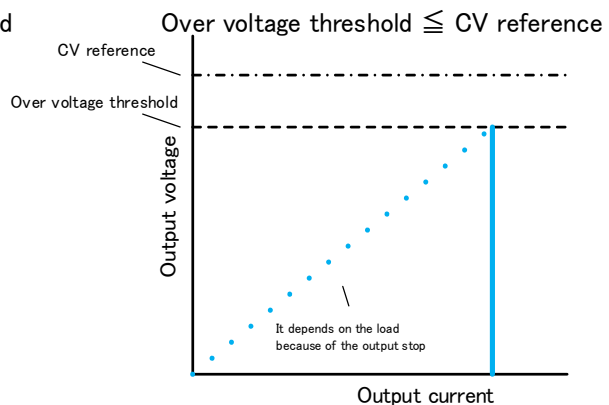
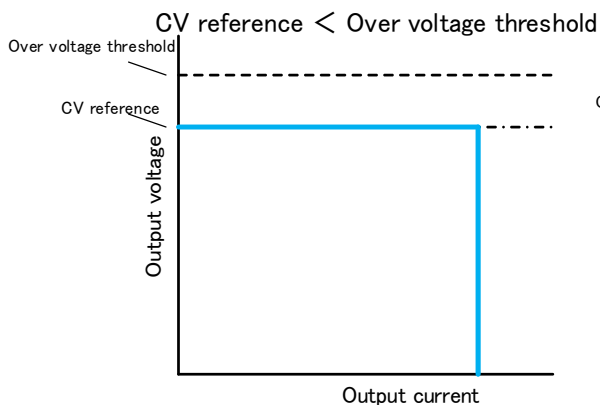

2) Register Read

<u>Request PDU</u>			Read Holdings.
Field	Byte	Value	
Function code	1	0x03	
Starting Address	2	105 (0x0069)	
Quantity of Registers	2	1 (0x0001)	

<u>Response PDU</u>			Read Holdings.
Field	Byte	Value	
Function code	1	0x03	
Byte count	1	2 (2 x 1)	
Registers value	2	Reading data.	

<u>Error PDU</u>			Read Holdings.
Field	Byte	Value	
Function code	1	0x83	
Exception code	1	0x02 / 0x04	

3) Register Write

<u>Request PDU</u>			Write Holding.
Field	Byte	Value	
Function code	1	0x06	
Starting Address	2	105 (0x0069)	
Registers value	2	writing data.	

<u>Response PDU</u>			Write Holding.
Field	Byte	Value	
Function code	1	0x06	
Starting Address	2	105 (0x0069)	
Register value	2	echo query data.	

<u>Error PDU</u>			Write Holding.
Field	Byte	Value	
Function code	1	0x86	
Exception code	1	0x02 / 0x03 / 0x04	

8 Register Name Over Current Threshold

Data Type	Register Function	Starting Address	Qty	Non-volatile
Holding	Threshold value of output over current.	106 (0x006A)	1	Yes

1) Register Details

This register sets the threshold value of output overcurrent.

The threshold value is handled as Q10 format data normalized by the maximum current.

Configuration data is retained even when input is cut off.

•Register value

Data Type	Max	Min	Factory setting	Unit	Accuracy
Normalization [Q10]	1.2	0.2	1.2	-	+ / - 3.0 % (Ta=25°C)
(Integer notation)	1229	204	1229	-	-

*An exception response (Exception code: 0x03) is returned when writing values outside the range.

*This accuracy mean that with respect to the maximum output current, the ratio of difference between the detection threshold set value and the power supply output current at protection operation.

Pay attention to the magnitude relation with the CC reference value.

The behavior of GXE may change.

CC reference < Over current threshold : The output voltage drops when an overload occurs.

Over current threshold \leq CC reference : GXE output stops when an overload occurs.

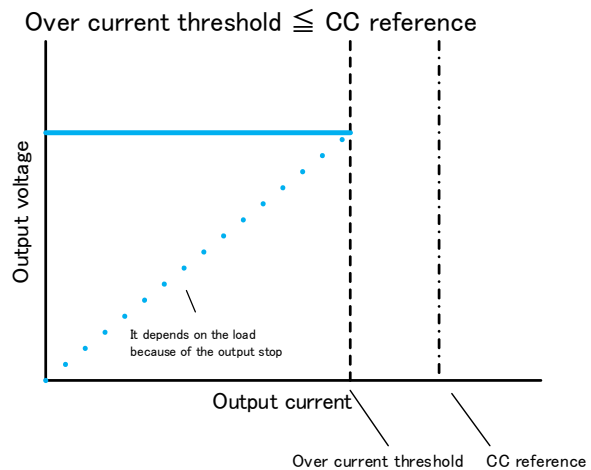
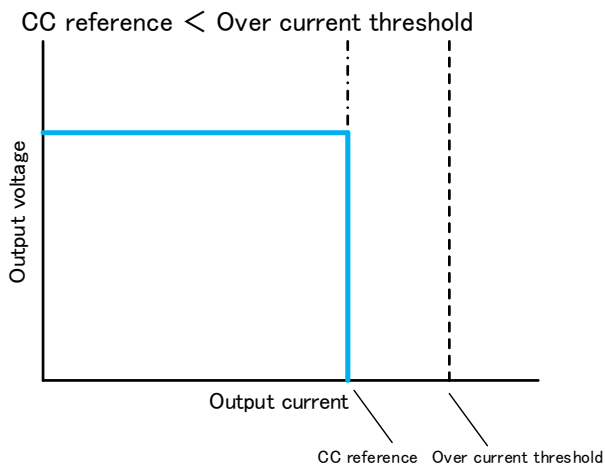

2) Register Read

<u>Request PDU</u>			Read Holdings.
Field	Byte	Value	
Function code	1	0x03	
Starting Address	2	106 (0x006A)	
Quantity of Registers	2	1 (0x0001)	

<u>Response PDU</u>			Read Holdings.
Field	Byte	Value	
Function code	1	0x03	
Byte count	1	2 (2 x 1)	
Registers value	2	Reading data.	

<u>Error PDU</u>			Read Holdings.
Field	Byte	Value	
Function code	1	0x83	
Exception code	1	0x02 / 0x04	

3) Register Write

<u>Request PDU</u>			Write Holding.
Field	Byte	Value	
Function code	1	0x06	
Starting Address	2	106 (0x006A)	
Registers value	2	writing data.	

<u>Response PDU</u>			Write Holding.
Field	Byte	Value	
Function code	1	0x06	
Starting Address	2	106 (0x006A)	
Register value	2	echo query data.	

<u>Error PDU</u>			Write Holding.
Field	Byte	Value	
Function code	1	0x86	
Exception code	1	0x02 / 0x03 / 0x04	

9 Register Name CV Rising Time

Data Type	Register Function	Starting Address	Qty	Non-volatile
Holding	Voltage slew rate at output start	107 (0x006B)	1	Yes

1) Register Details

This is the configuration register for voltage slew rate when GXE starts outputting.

The CV slew rate (dv / dt) is specified as the time required for the CV reference value to change from 0% to 100%.

Configuration data is retained even when input is cut off.

•Register value

Data Type	Max	Min	Factory setting	Unit
16 bit integer	10000	20	20	ms

*An exception response (Exception code: 0x03) is returned when writing values outside the range.

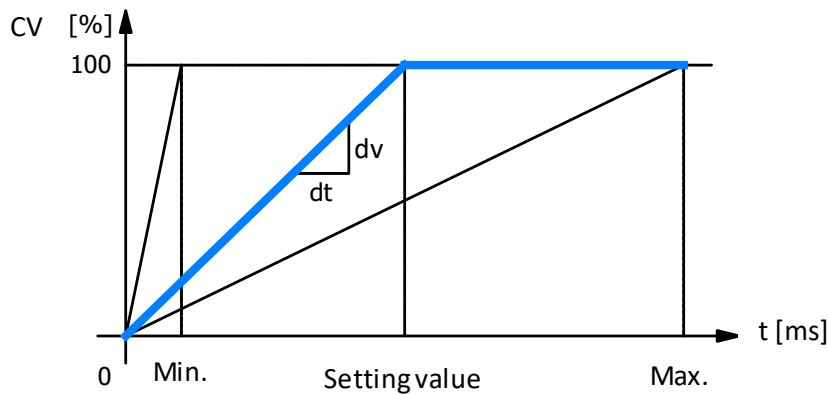

This function is the setting of the reference value, and it does not necessarily operate as set up.

Depending on the load impedance, the output voltage may not follow the CV reference.

CV reference value is changed during steady state, the slew rate setting of the [CV Transition Time] register is applied, not this register.

This register is set by time, but it is used to determine the slew rate.

Actual changing time is equivalent to Δ CV reference value / rated value.

Example) CV reference value : 1.1 [Q10] , Register setting value : 1000 [ms]

$$\begin{aligned} \text{Actual changing time} &= \text{Register setting value} \times \text{CV reference value} / \text{Rated value} \\ &= 1000 \times 1.1 / 1.0 = 1100 \text{ [ms]} \end{aligned}$$

2) Register Read

Request PDU			Read Holdings.
Field	Byte	Value	
Function code	1	0x03	
Starting Address	2	107 (0x006B)	
Quantity of Registers	2	1 (0x0001)	

Response PDU			Read Holdings.
Field	Byte	Value	
Function code	1	0x03	
Byte count	1	2 (2 x 1)	
Registers value	2	Reading data.	

Error PDU			Read Holdings.
Field	Byte	Value	
Function code	1	0x83	
Exception code	1	0x02 / 0x04	

3) Register Write

Request PDU			Write Holding.
Field	Byte	Value	
Function code	1	0x06	
Starting Address	2	107 (0x006B)	
Registers value	2	writing data.	

Response PDU			Write Holding.
Field	Byte	Value	
Function code	1	0x06	
Starting Address	2	107 (0x006B)	
Register value	2	echo query data.	

Error PDU			Write Holding.
Field	Byte	Value	
Function code	1	0x86	
Exception code	1	0x02 / 0x03 / 0x04	

10 **Register Name** CC Rising Time

Data Type	Register Function	Starting Address	Qty	Non-volatile
Holding	Current slew rate at output start	108 (0x006C)	1	Yes

1) Register Details

This is the configuration register for current slew rate when GXE starts outputting.

The CC slew rate (di / dt) is specified as the time required for the CC reference value to change from 0% to 100%.

Configuration data is retained even when input is cut off.

•Register value

Data Type	Max	Min	Factory setting	Unit
16 bit integer	10000	20	20	ms

*An exception response (Exception code: 0x03) is returned when writing values outside the range.

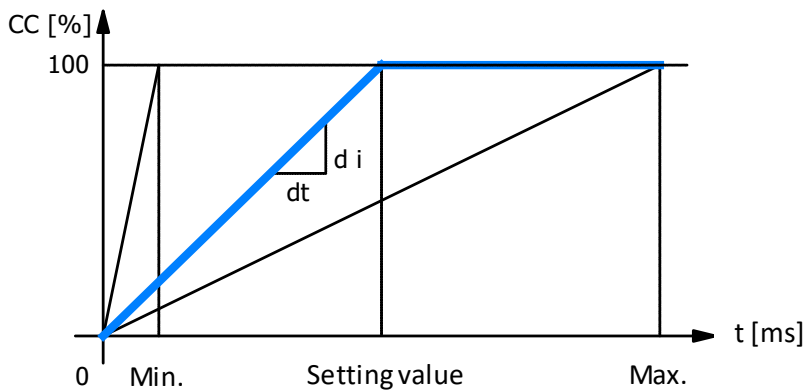

This function is the setting of the reference value, and it does not necessarily operate as set up.

Depending on the load impedance, the output current may not follow the CC reference.

CC reference value is changed during steady state, the slew rate setting of the [CC Transition Time] register is applied, not this register.

This register is set by time, but it is used to determine the slew rate.

Actual changing time is equivalent to Δ CC reference value / rated value.

Example) CC reference value : 0.85 [Q10] , Register setting value : 10000 [ms]

$$\begin{aligned} \text{Actual changing time} &= \text{Register setting value} \times \text{CC reference value} / \text{Rated value} \\ &= 10000 \times 0.85 / 1.0 = 8500 \text{ [ms]} \end{aligned}$$

2) Register Read

Request PDU			Read Holdings.
Field	Byte	Value	
Function code	1	0x03	
Starting Address	2	108 (0x006C)	
Quantity of Registers	2	1 (0x0001)	

Response PDU			Read Holdings.
Field	Byte	Value	
Function code	1	0x03	
Byte count	1	2 (2 x 1)	
Registers value	2	Reading data.	

Error PDU			Read Holdings.
Field	Byte	Value	
Function code	1	0x83	
Exception code	1	0x02 / 0x04	

3) Register Write

Request PDU			Write Holding.
Field	Byte	Value	
Function code	1	0x06	
Starting Address	2	108 (0x006C)	
Registers value	2	writing data.	

Response PDU			Write Holding.
Field	Byte	Value	
Function code	1	0x06	
Starting Address	2	108 (0x006C)	
Register value	2	echo query data.	

Error PDU			Write Holding.
Field	Byte	Value	
Function code	1	0x86	
Exception code	1	0x02 / 0x03 / 0x04	

11 Register Name CV Transition Time

Data Type	Register Function	Starting Address	Qty	Non-volatile
Holding	Voltage slew rate at steady state setting	109 (0x006D)	1	Yes

1) Register Details

This is the configuration register for slew rate when CV reference value is changed during steady state.

The CV slew rate (dv / dt) is specified as the time required for the CV reference value to change from 0% to 100%.

Please do one of the following methods to validate the setting value.

- Re-input
- From Remote Off to Remote On

Configuration data is retained even when input is cut off.

•Register setting value

Data Type	Max	Min	Factory setting	Unit
16 bit integer	10000	20	20	ms

*An exception response (Exception code: 0x03) is returned when writing values outside the range.

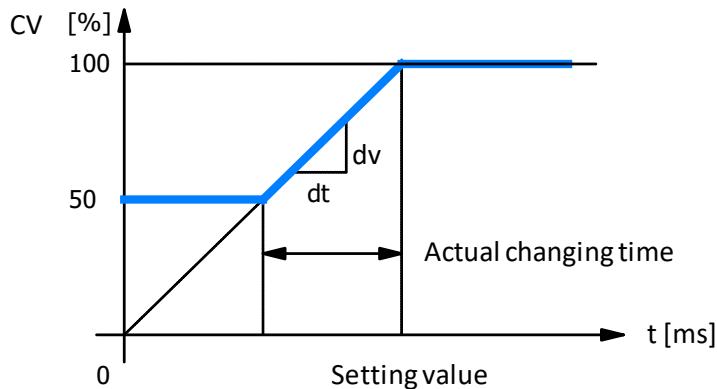

This function is the setting of the reference value, and it does not necessarily operate as set up.

Depending on the load impedance, the output current may not follow the CV reference.

To change the CV value at startup, the slew rate setting of the [CV Rising Time] register is applied, not this register.

The value set here is the time required for a change of 0% \Rightarrow 100%

Actual changing time is equivalent to Δ CV reference value / rated value.

Example) CV reference value : 0.5 \Rightarrow 1.0 [Q10], Register setting value : 1000 [ms]

$$\begin{aligned} \text{Actual changing time} &= \text{Register setting value} \times \Delta \text{ CV reference value} / \text{Rated value} \\ &= 1000 \times (1.0 - 0.5) / 1.0 = 500 \text{ [ms]} \end{aligned}$$

2) Register Read

Request PDU			Read Holdings.
Field	Byte	Value	
Function code	1	0x03	
Starting Address	2	109 (0x006D)	
Quantity of Registers	2	(0x0000)	

Response PDU			Read Holdings.
Field	Byte	Value	
Function code	1	0x03	
Byte count	1	2 (2 x 1)	
Registers value	2	Reading data.	

Error PDU			Read Holdings.
Field	Byte	Value	
Function code	1	0x83	
Exception code	1	0x02 / 0x04	

3) Register Write

Request PDU			Write Holding.
Field	Byte	Value	
Function code	1	0x06	
Starting Address	2	109 (0x006D)	
Registers value	2	writing data.	

Response PDU			Write Holding.
Field	Byte	Value	
Function code	1	0x06	
Starting Address	2	109 (0x006D)	
Register value	2	echo query data.	

Error PDU			Write Holding.
Field	Byte	Value	
Function code	1	0x86	
Exception code	1	0x02 / 0x03 / 0x04	

12 **Register Name** CC Transition Time

Data Type	Register Function	Starting Address	Qty	Non-volatile
Holding	Current slew rate at steady state setting	110 (0x006E)	1	Yes

1) Register Details

This is the configuration register for slew rate when CC reference value is changed during steady state.

The CC slew rate (di / dt) is specified as the time required for the CC reference value to change from 0% to 100%.

Please do one of the following methods to validate the setting value.

- Re-input
- From Remote Off to Remote On

Configuration data is retained even when input is cut off.

•Register setting value

Data Type	Max	Min	Factory setting	Unit
16 bit integer	10000	20	20	ms

*An exception response (Exception code: 0x03) is returned when writing values outside the range.

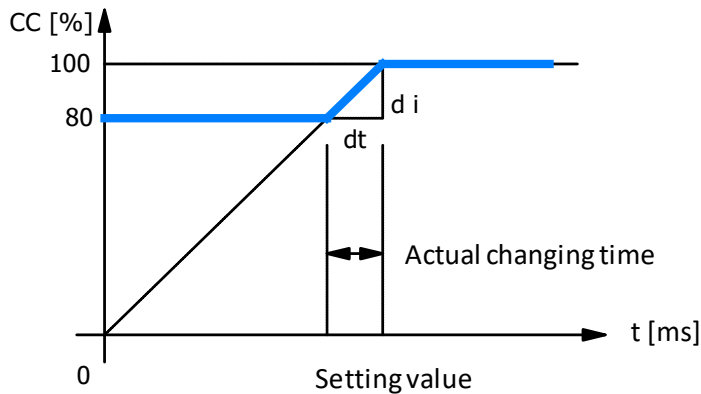

This function is the setting of the reference value, and it does not necessarily operate as set up.

Depending on the load impedance, the output current may not follow the CC reference.

To change the CC value at startup, the slew rate setting of the [CC Rising Time] register is applied, not this register.

The value set here is the time required for a change of 0% ⇒ 100%

Actual changing time is equivalent to Δ CC reference value / rated value.

Example) CC reference value : 0.8 ⇒ 1.0 [Q10], Register setting value : 1000 [ms]

$$\begin{aligned} \text{Actual changing time} &= \text{Register setting value} \times \Delta \text{ CC reference value} / \text{Rated value} \\ &= 1000 \times (1.0 - 0.8) / 1.0 = 200 \text{ [ms]} \end{aligned}$$

2) Register Read

Request PDU			Read Holdings.
Field	Byte	Value	
Function code	1	0x03	
Starting Address	2	110 (0x006E)	
Quantity of Registers	2	1 (0x0001)	

Response PDU			Read Holdings.
Field	Byte	Value	
Function code	1	0x03	
Byte count	1	2 (2 x 1)	
Registers value	2	Reading data.	

Error PDU			Read Holdings.
Field	Byte	Value	
Function code	1	0x83	
Exception code	1	0x02 / 0x04	

3) Register Write

Request PDU			Write Holding.
Field	Byte	Value	
Function code	1	0x06	
Starting Address	2	110 (0x006E)	
Registers value	2	writing data.	

Response PDU			Write Holding.
Field	Byte	Value	
Function code	1	0x06	
Starting Address	2	110 (0x006E)	
Register value	2	echo query data.	

Error PDU			Write Holding.
Field	Byte	Value	
Function code	1	0x86	
Exception code	1	0x02 / 0x03 / 0x04	

13 Register Name PF Threshold

Data Type	Register Function	Starting Address	Qty	Non-volatile
Holding	PF detection threshold setting	111 (0x006F)	1	Yes

1) Register Details

This is the configuration register for detection threshold when outputting PF signal.

The PF detection threshold value is specified by signed 16-bit integer as "%" with CV reference value or CC reference value as 100%.

The PF signal detection target is selected by the "PF mode setting register".

Configuration data is retained even when input is cut off.

•Register setting value

Data Type	Max	Min	Factory setting	Unit
16 bit integer	95	50	80	%

*An exception response (Exception code: 0x03) is returned when writing values outside the range.

The PF detection threshold is compared with the detection target, and when the target falls below the threshold value, the PF signal is output.

The detection target is selected by [PF mode] register setting and the target is output voltage or output current.

PF signal update cycle is every 1 ms.

The output display LED of the power supply unit turn off in synchronization with the PF signal output.

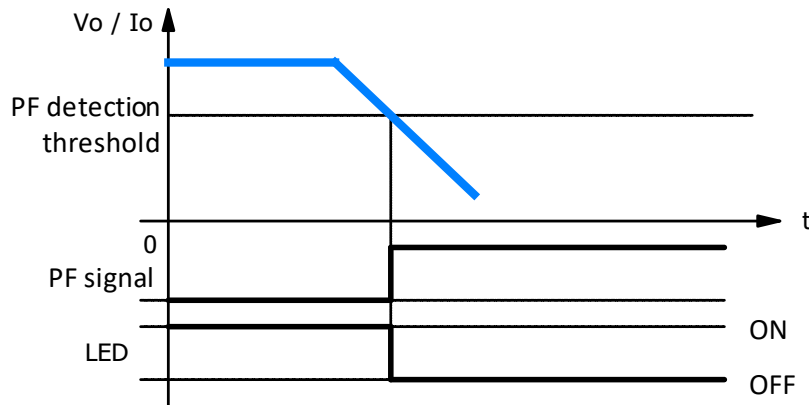

In order to prevent signal fluttering, it is possible to set the confirmation time limit by setting the [PF count] register.

Also, when a voltage is applied to the output terminal of the power supply from the outside, if the PF threshold is exceeded, the PF signal will be canceled, but not in sleep mode.

For details, Refer to the instruction manual.

2) Register Read

<u>Request PDU</u>			Read Holdings.
Field	Byte	Value	
Function code	1	0x03	
Starting Address	2	111 (0x006F)	
Quantity of Registers	2	1 (0x0001)	

<u>Response PDU</u>			Read Holdings.
Field	Byte	Value	
Function code	1	0x03	
Byte count	1	2 (2 x 1)	
Registers value	2	Reading data.	

<u>Error PDU</u>			Read Holdings.
Field	Byte	Value	
Function code	1	0x83	
Exception code	1	0x02 / 0x04	

3) Register Write

<u>Request PDU</u>			Write Holding.
Field	Byte	Value	
Function code	1	0x06	
Starting Address	2	111 (0x006F)	
Registers value	2	writing data.	

<u>Response PDU</u>			Write Holding.
Field	Byte	Value	
Function code	1	0x06	
Starting Address	2	111 (0x006F)	
Register value	2	echo query data.	

<u>Error PDU</u>			Write Holding.
Field	Byte	Value	
Function code	1	0x86	
Exception code	1	0x02 / 0x03 / 0x04	

14 **Register Name PF mode**

Data Type	Register Function	Starting Address	Qty	Non-volatile
Holding	PF mode setting	112 (0x0070)	1	Yes

1) Register Details

This is the configuration register for detection target when outputting a PF (Power Fail) signal.

Specify output voltage or output current as detection target by register setting value.

Use this register to select the operation mode suitable for the user's system.

The PF detection threshold is set by the PF threshold setting register.

Configuration data is retained even when input is cut off.

The meanings of register setting values are shown below.

Bit	Mode	Function
0	CV_Pf	Outputs the PF signal when the output voltage drops below the PF threshold
1	CC_Pf	Outputs the PF signal when the output current drops below the PF threshold

•Register setting value

Data Type	CC_Pf	CV_Pf	Factory setting	Unit
16 bit integer	1	0	0 (CV)	-

* If an unspecified value is written, only the lowest bit is accepted as a valid value.

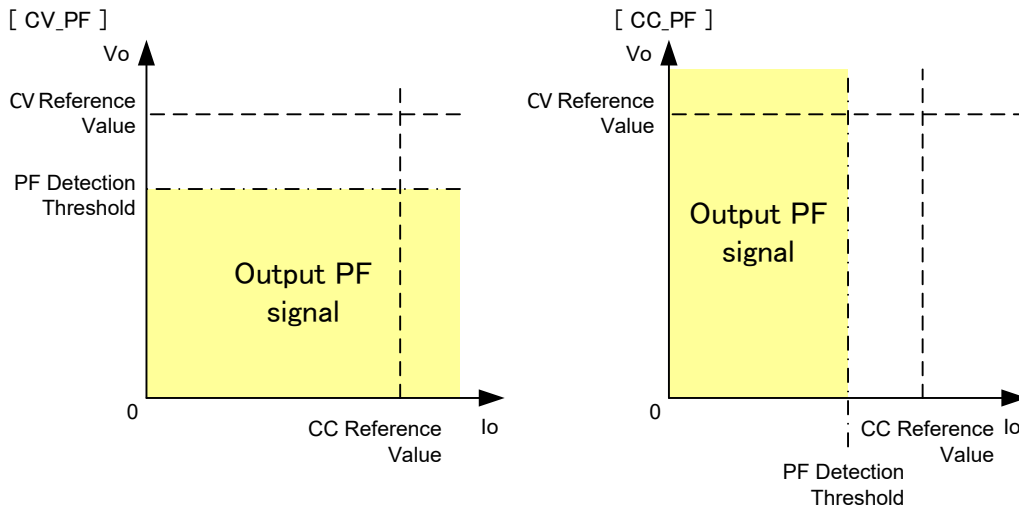

2) Register Read

Request PDU			Read Holdings.
Field	Byte	Value	
Function code	1	0x03	
Starting Address	2	112 (0x0070)	
Quantity of Registers	2	1 (0x0001)	

Response PDU			Read Holdings.
Field	Byte	Value	
Function code	1	0x03	
Byte count	1	2 (2 x 1)	
Registers value	2	Reading data.	

Error PDU			Read Holdings.
Field	Byte	Value	
Function code	1	0x83	
Exception code	1	0x02 / 0x04	

3) Register Write

Request PDU			Write Holding.
Field	Byte	Value	
Function code	1	0x06	
Starting Address	2	112 (0x0070)	
Registers value	2	writing data.	

Response PDU			Write Holding.
Field	Byte	Value	
Function code	1	0x06	
Starting Address	2	112 (0x0070)	
Register value	2	echo query data.	

Error PDU			Write Holding.
Field	Byte	Value	
Function code	1	0x86	
Exception code	1	0x02 / 0x03 / 0x04	

15 Register Name PF Count

Data Type	Register Function	Starting Address	Qty	Non-volatile
Holding	PF signal output confirmation time limit setting	113 (0x0071)	1	Yes

1) Register Details

This is the configuration register for PF (Power Fail) signal output confirmation time (delay time).

The setting value is specified by integer data [ms].

When the output is below the PF detection threshold for a time longer than the set time, the PF signal is output

When the output returns to the PF detection threshold or higher within the set time, the PF signal is not output.

The PF signal detection level is set in the PF threshold register.

The PF signal detection target is selected by the PF mode setting register.

Configuration data is retained even when input is cut off.

•Register setting value

Data Type	Max	Min	Factory setting	Unit
16 bit integer	100	0	0	ms

*An exception response (Exception code: 0x03) is returned when writing values outside the range.

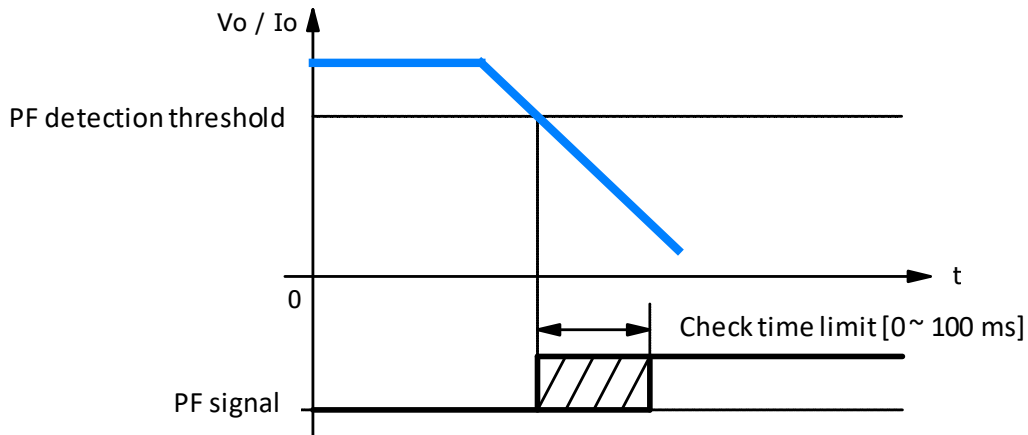

2) Register Read

<u>Request PDU</u>			Read Holdings.
Field	Byte	Value	
Function code	1	0x03	
Starting Address	2	113 (0x0071)	
Quantity of Registers	2	1 (0x0001)	

<u>Response PDU</u>			Read Holdings.
Field	Byte	Value	
Function code	1	0x03	
Byte count	1	2 (2 x 1)	
Registers value	2	Reading data.	

<u>Error PDU</u>			Read Holdings.
Field	Byte	Value	
Function code	1	0x83	
Exception code	1	0x02 / 0x04	

3) Register Write

<u>Request PDU</u>			Write Holding.
Field	Byte	Value	
Function code	1	0x06	
Starting Address	2	113 (0x0071)	
Registers value	2	writing data.	

<u>Response PDU</u>			Write Holding.
Field	Byte	Value	
Function code	1	0x06	
Starting Address	2	113 (0x0071)	
Register value	2	echo query data.	

<u>Error PDU</u>			Write Holding.
Field	Byte	Value	
Function code	1	0x86	
Exception code	1	0x02 / 0x03 / 0x04	

16 **Register Name** Auto Recovery Time

Data Type	Register Function	Starting Address	Qty	Non-volatile
Holding	Automatic recovery time during protection function operation setting	114 (0x0072)	1	Yes

1) Register Details

This is the configuration register for automatic recovery time during protection function operation.

Specify the wait time until protection is canceled when protection function set to "auto recovery" operates with integer data [unit 10 ms].

If the protection factor continues to occur or the protection function specified for latch stop is operating, the output will not be resumed even if the automatic recovery time has elapsed.

The factory setting is set to 100 (100 x 10 ms = 1 s).

Depending on the timing of the internal processing of the power supply, several tens of msec is added to the automatic recovery time.

Configuration data is retained even when input is cut off.

•Register setting value

Data Type	Max	Min	Factory setting	Unit
16 bit integer	1000	100	100	10 ms

*An exception response (Exception code: 0x03) is returned when writing values outside the range.

Example) When SWOCP factor is set to automatic recovery

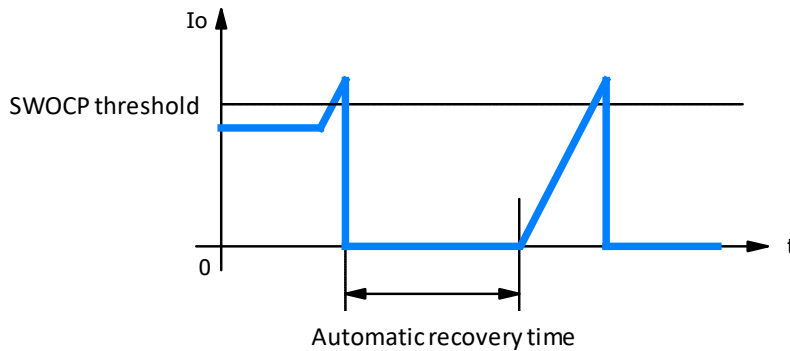

2) Register Read

Request PDU			Read Holdings.
Field	Byte	Value	
Function code	1	0x03	
Starting Address	2	114 (0x0072)	
Quantity of Registers	2	1 (0x0001)	

Response PDU			Read Holdings.
Field	Byte	Value	
Function code	1	0x03	
Byte count	1	2 (2 x 1)	
Registers value	2	Reading data.	

Error PDU			Read Holdings.
Field	Byte	Value	
Function code	1	0x83	
Exception code	1	0x02 / 0x04	

3) Register Write

Request PDU			Write Holding.
Field	Byte	Value	
Function code	1	0x06	
Starting Address	2	114 (0x0072)	
Registers value	2	writing data.	

Response PDU			Write Holding.
Field	Byte	Value	
Function code	1	0x06	
Starting Address	2	114 (0x0072)	
Register value	2	echo query data.	

Error PDU			Write Holding.
Field	Byte	Value	
Function code	1	0x86	
Exception code	1	0x02 / 0x03 / 0x04	

17 **Register Name** Clear Alarm History

Data Type	Register Function	Starting Address	Qty	Non-volatile
Holding	Alarm history erase	115 (0x0073)	1	No

1) Register Details

This register is used to request clearance of alarm history.

This clear request is done to both [Alarm History (Volatile)] and [Alarm History (Non-Volatile)].

Normally, the contents of the alarm history register are automatically erased when switching from Remote Off to Remote On, but by writing this register, it is also possible to erase the history.

•Use Case 1

By polling the operations of read [Alarm history] register and write [Clear Alarm History] register, it is possible to acquire only new protection factors that occurred during polling.

•Use Case 2

It is a specification that the alarm history remains even when the protection function with automatic recovery setting operates. When the current alarm history is unnecessary, this function can clear the alarm history without stopping the power supply.

•Register setting value

Data Type	Clear	Ignore	Unit
16 bit integer	1	0	-

* If an unspecified value is written, only the lowest bit is accepted as a valid value.

2) Register Read

This register is write-only, and an exception response (exception code: 0x03) is returned for a read query.

3) Register Write

Request PDU		Write Holding.
Field	Byte	Value
Function code	1	0x06
Starting Address	2	115 (0x0073)
Registers value	2	writing data.

Response PDU		Write Holding.
Field	Byte	Value
Function code	1	0x06
Starting Address	2	115 (0x0073)
Register value	2	echo query data.

Error PDU		Write Holding.
Field	Byte	Value
Function code	1	0x86
Exception code	1	0x02 / 0x03 / 0x04

18 **Register Name** Clear PF Output Time

Data Type	Register Function	Starting Address	Qty	Non-volatile
Holding	PF output time erase	116 (0x0074)	1	No

* This register is not available for the firmware version 3.000 and 3.001.

1) Register Details

This register is used to request clearance of [PF Output Time] register.

•Register setting value

Data Type	Clear	Ignore	Unit
16 bit integer	1	0	-

* If an unspecified value is written, only the lowest bit is accepted as a valid value.

2) Register Read

This register is write-only, and an exception response (exception code: 0x03) is returned for a read query.

3) Register Write

Request PDU		Write Holding.
Field	Byte	Value
Function code	1	0x06
Starting Address	2	116 (0x0074)
Registers value	2	writing data.

Response PDU		Write Holding.
Field	Byte	Value
Function code	1	0x06
Starting Address	2	116 (0x0074)
Register value	2	echo query data.

Error PDU		Write Holding.
Field	Byte	Value
Function code	1	0x86
Exception code	1	0x02 / 0x03 / 0x04

19 **Register Name Slave ID**

Data Type	Register Function	Starting Address	Qty	Non-volatile
Holding	MODBUS serial line slave ID setting	200 (0x00C8)	1	Yes

1) Register Details

This is the configuration register for slave ID.

According to the MODBUS specification, the slave ID is specified as integer data in the range from 1 to 247.

In order to avoid misconfiguration, setting update by broadcast is ignored in only this register.

Configuration data is retained even when input is cut off.

•Register setting value

Data Type	Max	Min	Factory setting	Default	Unit
16 bit integer	247	1	1	1	-

*An exception response (Exception code: 0x03) is returned when writing values outside the range.

GXEs connected to communication line must have a unique slave ID.

Before connect to communication line, set each GXE so that the slave ID does not overlap.

This register is used for opening the communication port when the power supply starts up, and is not referred to during operation.

Even after updating the register setting value, the transmission and reception of the query/response is performed by the configuration at the time of startup.

As an exception, when communication reinitialization of the diagnostic query (FC : 0x08 / SC : 0x0001) is accepted, the updated configuration is applied because the communication port is reopened.

When AC input is turned on with the communication setting switch set to invalid (DIS), the value of this register is not referred and communication is performed with the default value.

2) Register Read

Request PDU			Read Holdings.
Field	Byte	Value	
Function code	1	0x03	
Starting Address	2	200 (0x00C8)	
Quantity of Registers	2	1 (0x0001)	

Response PDU			Read Holdings.
Field	Byte	Value	
Function code	1	0x03	
Byte count	1	2 (2 x 1)	
Registers value	2	Reading data.	

Error PDU			Read Holdings.
Field	Byte	Value	
Function code	1	0x83	
Exception code	1	0x02 / 0x04	

3) Register Write

Request PDU			Write Holding.
Field	Byte	Value	
Function code	1	0x06	
Starting Address	2	200 (0x00C8)	
Registers value	2	writing data.	

Response PDU			Write Holding.
Field	Byte	Value	
Function code	1	0x06	
Starting Address	2	200 (0x00C8)	
Register value	2	echo query data.	

Error PDU			Write Holding.
Field	Byte	Value	
Function code	1	0x86	
Exception code	1	0x02 / 0x03 / 0x04	

20 **Register Name Baud Rate**

Data Type	Register Function	Starting Address	Qty	Non-volatile
Holding	MODBUS serial line communication speed setting	201 (0x00C9)	1	Yes

1) Register Details

This is the configuration register for communication speed.

Specify the set value with integer data in the range of the table below.

Configuration data is retained even when input is cut off.

•Register setting value

Data Type	Max	Min	Factory setting	Default	Unit
16 bit integer	3	0	3	3	–

*An exception response (Exception code: 0x03) is returned when writing values outside the range.

The meanings of register setting values are shown below.

Value	Description
0	2400 bps
1	4800 bps
2	9600 bps
3	19200 bps

This register is used for opening the communication port when the power supply starts up, and is not referred to during operation.

Even after updating the register setting value, the transmission and reception of the query/response is performed by the configuration at the time of startup.

As an exception, when communication reinitialization of the diagnostic query (FC : 0x08 / SC : 0x0001) is accepted, the updated configuration is applied because the communication port is reopened.

When AC input is turned on with the communication setting switch set to invalid (DIS), the value of this register is not referred and communication is performed with the default value.

2) Register Read

Request PDU			Read Holdings.
Field	Byte	Value	
Function code	1	0x03	
Starting Address	2	201 (0x00C9)	
Quantity of Registers	2	1 (0x0001)	

Response PDU			Read Holdings.
Field	Byte	Value	
Function code	1	0x03	
Byte count	1	2 (2 x 1)	
Registers value	2	Reading data.	

Error PDU			Read Holdings.
Field	Byte	Value	
Function code	1	0x83	
Exception code	1	0x02 / 0x04	

3) Register Write

Request PDU			Write Holding.
Field	Byte	Value	
Function code	1	0x06	
Starting Address	2	201 (0x00C9)	
Registers value	2	writing data.	

Response PDU			Write Holding.
Field	Byte	Value	
Function code	1	0x06	
Starting Address	2	201 (0x00C9)	
Register value	2	echo query data.	

Error PDU			Write Holding.
Field	Byte	Value	
Function code	1	0x86	
Exception code	1	0x02 / 0x03 / 0x04	

21 **Register Name** Parity

Data Type	Register Function	Starting Address	Qty	Non-volatile
Holding	MODBUS serial line transmission code configuration setting	202 (0x00CA)	1	Yes

1) Register Details

This is the configuration register for transmission code (parity bit / stop bit).

Specify the set value with integer data in the range of the table below.

Configuration data is retained even when input is cut off.

•Register setting value

Data Type	Max	Min	Factory setting	Default	Unit
16 bit integer	2	0	2	2	-

*An exception response (Exception code: 0x03) is returned when writing values outside the range.

The meanings of register setting values are shown below.

Value	Description
0	No parity, 2 stop bits
1	Odd parity, 1 stop bit
2	Even parity, 1 stop bit

The character transmission length of the MODBUS protocol consists of eleven bits of [1 start bit + 8 data bits + 1 parity bit + 1 stop bit], in the case of no parity it is 2 stop bits and the transmission length 11 bits are maintain.

This register is used for opening the communication port when the power supply starts up, and is not referred to during operation. Even after updating the register setting value, the transmission and reception of the query/response is performed by the configuration at the time of startup.

As an exception, when communication reinitialization of the diagnostic query (FC : 0x08 / SC : 0x0001) is accepted, the updated configuration is applied because the communication port is reopened.

When AC input is turned on with the communication setting switch set to invalid (DIS), the value of this register is not referred and communication is performed with the default value.

2) Register Read

Request PDU			Read Holdings.
Field	Byte	Value	
Function code	1	0x03	
Starting Address	2	202 (0x00CA)	
Quantity of Registers	2	1 (0x0001)	

Response PDU			Read Holdings.
Field	Byte	Value	
Function code	1	0x03	
Byte count	1	2 (2 x 1)	
Registers value	2	Reading data.	

Error PDU			Read Holdings.
Field	Byte	Value	
Function code	1	0x83	
Exception code	1	0x02 / 0x04	

3) Register Write

Request PDU			Write Holding.
Field	Byte	Value	
Function code	1	0x06	
Starting Address	2	202 (0x00CA)	
Registers value	2	writing data.	

Response PDU			Write Holding.
Field	Byte	Value	
Function code	1	0x06	
Starting Address	2	202 (0x00CA)	
Register value	2	echo query data.	

Error PDU			Write Holding.
Field	Byte	Value	
Function code	1	0x86	
Exception code	1	0x02 / 0x03 / 0x04	

22 **Register Name** Scratch Pad1 / Scratch Pad2

Data Type	Register Function	Starting Address	Qty	Non-volatile
Holding	User data storage area 1	300 (0x012C)	15	Yes
Holding	User data storage area 2	320 (0x0140)	15	Yes

1) Register Details

This is the register that the user can freely store data.

Configuration data is retained even when input is cut off.

It consists of consecutive 16x15 bit areas and can store up to 30 characters of ASCII characters.

There is no limit to the saved data. (Data other than readable characters is also valid)

The "scratch pad" register block is open for host devices, and GXE does not care about register contents.

GXE provides two pairs of "scratch pad" register blocks.

When accessing a register, an arbitrary data length of 1 word or more up to the register block size length can be specified.

Because it is accessed in 16-bit units, padding ('0x00' Recommended) is required so that even bytes are stored when storing odd byte data.

Example) Write 9 bytes string data "User Data" to the "Scratch Pad 1" register.

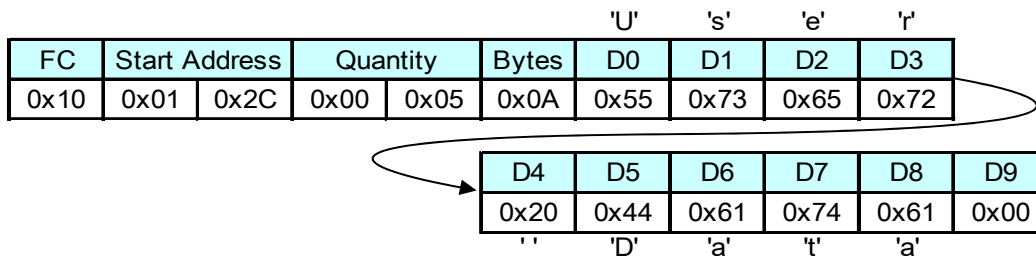

In order to access registers with 5 words, 1 byte of data padding is required.

2) Register Read

Request PDU		Read Scratch Pad 1.	Read Scratch Pad 2.
Field	Byte	Value	Value
Function code	1	0x03	0x03
Starting Address	2	300 (0x012C)	320 (0x0140)
Quantity of Registers	2	1 to 15 (0x0001 – 0x000F)	1 to 15 (0x0001 – 0x000F)

Response PDU		Read Holdings.	
Field	Byte	Value	Value
Function code	1	0x03	0x03
Byte count	1	2 x N*	2 x N*
Registers value	N* x 2	Reading data.	Reading data.

*N = Quantity of Registers

Error PDU		Read Holdings.	
Field	Byte	Value	Value
Function code	1	0x83	0x83
Exception code	1	0x02 / 0x04	0x02 / 0x04

3) Register Write

Request PDU		Write Scratch Pad 1.	Write Scratch Pad 2.
Field	Byte	Value	Value
Function code	1	0x10	0x10
Starting Address	2	300 (0x012C)	320 (0x0140)
Quantity of Registers	2	1 to 15 (0x0001 – 0x000F)	1 to 15 (0x0001 – 0x000F)
Byte count	1	2 x N*	2 x N*
Registers value	N* x 2	writing data.	writing data.

*N = Quantity of Registers

Response PDU		Write Scratch Pad 1.	Write Scratch Pad 2.
Field	Byte	Value	Value
Function code	1	0x10	0x10
Starting Address	2	300 (0x012C)	320 (0x0140)
Quantity of Registers	2	1 to 15 (0x0001 – 0x000F)	1 to 15 (0x0001 – 0x000F)

Error PDU		Write Scratch Pad 1 / 2.	
Field	Byte	Value	
Function code	1	0x90	
Exception code	1	0x02/0x03/0x04	

Supplementary

1. Communication configuration switch

It is possible to set and check all communication configurations of the GXE series by use communication lines.

GXE series don't have display function of the communication configuration.

When disconnecting GXE from communication bus line due to changing system configuration, etc., you might miss the communication configuration of it. If the communication configuration switch is disabled(DIS) and you apply input to GXE, GXE start with default communication configuration.

! To prevent electric shock, operate the switch after enough time has elapsed from input shutdown.

*Default Communication Configuration

Item	Default Setting
Slave ID	ID : 1
Baud Rate	19200 bps
Parity	Even parity
Stop bit	1 bit

By connecting to GXE with one to one by use this communication configuration, you can confirm or change to communication configuration of GXE.

! If the switch is disable(DIS) and plural GXEs connected to the bus, you cannot correct communication.

Step1: After sufficient time has elapsed since the input is cut off, switch the communication configuration switch to disable(DIS). Refer to the figure below for the location and direction of the switch.

Step2: After apply AC input, read the communication configuration related registers and check the setting contents.

Step3: Modify the register settings related to communication settings as necessary and update them.

Step4: After sufficient time has elapsed since the AC input was cut off, you switch the communication configuration switch to enable(EN).

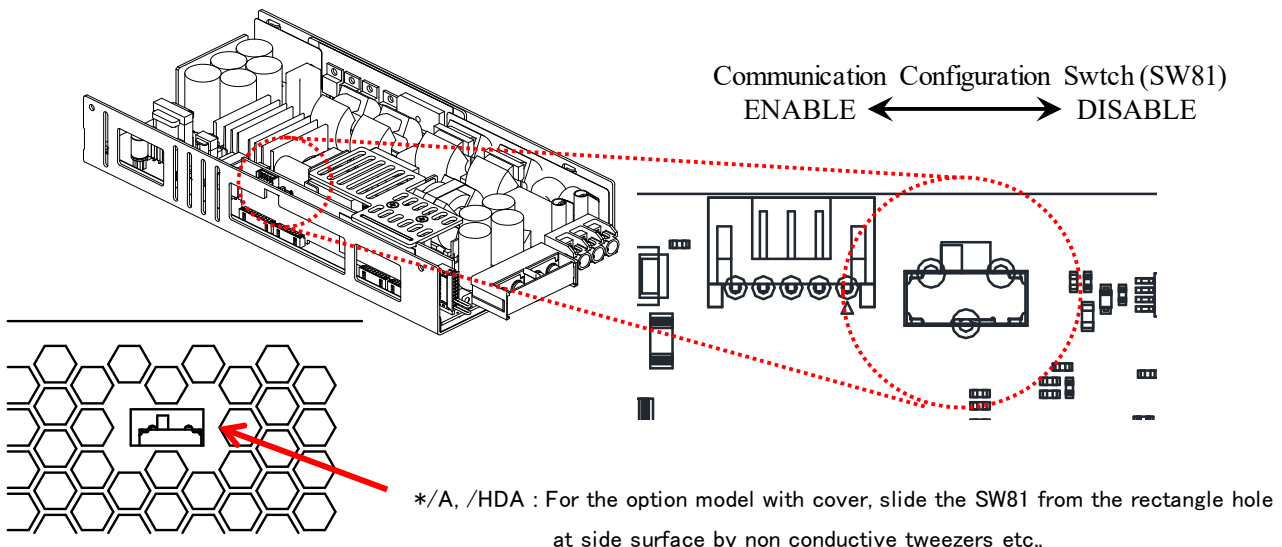

2. Q format

Q format is a numerical type for handling decimal virtually with integer data.

GXE treat all values as integers (Binary numbers).

So GXE handles numeric values with Q format data when you need decimal values.

In the Q format, when written as Qⁿ format, data is handled assuming that there is a decimal point between the "n" th bit and the "n - 1" th bit of the data.

Example) 1.25 [Q10]

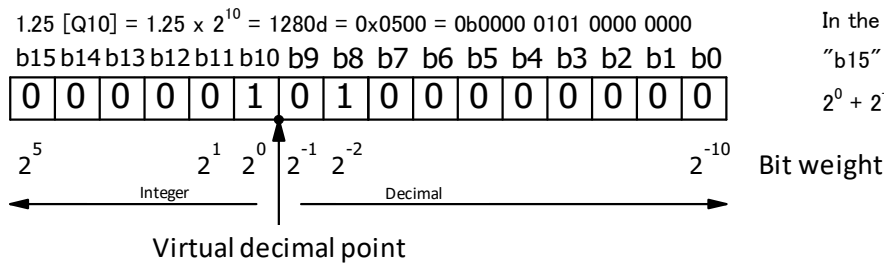

In the case of a signed integer,

"b15" is sign bit.

$$2^0 + 2^{-2} = 1 + 0.25 = 1.25$$

The numerical resolution becomes 2^{-n} . Example) In Q10 format, $2^{-10} = 1/1024$

Therefore, for values that cannot be divided by 2^{-n} , it shall be an approximate value.

For example, when decimal number is 0.1, decimal operation can be divided by first decimal place and value can be accurately expressed.

However, because binary operation can not divide the value, truncation errors occur even if the number of digits in the decimal part is increased.

Assuming that it is expressed in Q16 format [16 decimal places]

$$0.1 [Q16] = 0.1 \times 2^{16} = 6553d = 0x1999 = 0b0001\ 1001\ 1001\ 1001$$

It becomes a circulating binary decimal of 1100 from the bit weight of 2^{-4} .

Returning the value of this binary number to decimal number, it will be 0.0999908447265625.

(it will not be exact 0.1)

Because it is a circular decimal, truncation errors do not disappear even if infinitely increasing the number of digits.

•When the numerical data is normalized

The actual value is the reference value when the normalized data is 1.0.

As the numerical value becomes a decimal number, GXE handles normalized data in Q format.

•Conversion of physical quantity (voltage and current) and normalized data

Normalized data = physical quantity / reference value

Physical quantity = reference value x normalized data

•Example of output voltage measurement value of 24V model

Reference value = Nominal voltage = 24 [V]

When the output voltage = 23.5 [V]

Normalized data = $23.5 / 24 = 0.97917$

Q format representation of normalized data

Q10 format: INT (normalized data * 210) = 1002d = 0x03EA

Q14 Format: INT (normalized data * 214) = 16042d = 0x3EEA

Conversely, when converting the normalized data expressed in the Q format to the physical quantity

$$\text{Physical quantity} = \text{reference value} \times \text{Qn format data} \times 2^{-n}$$