

# CUS30M

## EVALUATION DATA

### 型式データ

## INDEX

1. 測定方法	Evaluation Method	PAGE
1.1 測定回路	Circuit used for determination	
測定回路 1	Circuit 1 used for determination .....	T-1
静特性	Steady state data	
過電流保護特性	Over current protection (OCP) characteristics	
過電圧保護特性	Over voltage protection (OVP) characteristics	
出力立ち上がり特性	Output rise characteristics	
出力立ち下がり特性	Output fall characteristics	
出力保持時間特性	Hold up time characteristics	
測定回路 2	Circuit 2 used for determination .....	T-1
過渡応答 (負荷急変) 特性	Dynamic load response characteristics	
測定回路 3	Circuit 3 used for determination .....	T-1
入力サージ電流 (突入電流) 波形	Inrush current waveform	
測定回路 4	Circuit 4 used for determination .....	T-2
リーク電流特性	Leakage current characteristics	
測定回路 5	Circuit 5 used for determination .....	T-2
出力リップル、ノイズ波形	Output ripple and noise waveform	
測定構成	Configuration used for determination .....	T-3
EMI特性	Electro-Magnetic Interference characteristics	
(a) 雑音端子電圧 (帰還ノイズ)	Conducted Emission	
(b) 雑音電界強度 (放射ノイズ)	Radiated Emission	
1.2 使用測定機器	List of equipment used .....	T-4
2. 特性データ	Characteristics	
2.1 静特性	Steady state data	
(1) 入力・負荷・温度変動／出力起動・遮断電圧	Regulation - line and load, Temperature drift	
/ Start up voltage and Drop out voltage .....		T-5~6
(2) 効率対出力電流	Efficiency vs. Output current .....	T-7~8
(3) 入力電流対出力電流	Input current vs. Output current .....	T-9~10
(4) 入力電力対出力電流	Input power vs. Output current .....	T-11~12
2.2 過電流保護特性	Over current protection (OCP) characteristics .....	T-13~14
2.3 過電圧保護特性	Over voltage protection (OVP) characteristics .....	T-15~17
2.4 出力立ち上がり特性	Output rise characteristics .....	T-18~19
2.5 出力立ち下がり特性	Output fall characteristics .....	T-20~21
2.6 出力保持時間特性	Hold up time characteristics .....	T-22~23
2.7 過渡応答 (負荷急変) 特性	Dynamic load response characteristics .....	T-24~27
2.8 入力電圧瞬停特性	Response to brown out characteristics .....	T-28~31
2.9 入力サージ電流 (突入電流) 波形	Inrush current waveform .....	T-32~34
2.10 リーク電流特性	Leakage current characteristics .....	T-35~43
2.11 出力リップル、ノイズ波形	Output ripple and noise waveform .....	T-44~47
2.12 EMI 特性	Electro-Magnetic Interference characteristics .....	T-48~71

## 使用記号 Terminology used

	定義	Definition
Vin	..... 入力電圧	Input voltage
Vout	..... 出力電圧	Output voltage
Iin	..... 入力電流	Input current
Iout	..... 出力電流	Output current
Ta	..... 周囲温度	Ambient temperature
f	..... 周波数	Frequency

1.1 測定回路 Circuit used for determination

測定回路1 Circuit 1 used for determination

- 静特性 Steady state data
- 過電流保護特性 Over current protection (OCP) characteristics
- 過電圧保護特性 Over voltage protection (OVP) characteristics
- 出力立ち上がり特性 Output rise characteristics
- 出力立ち下がり特性 Output fall characteristics
- 出力保持時間特性 Hold up time characteristics

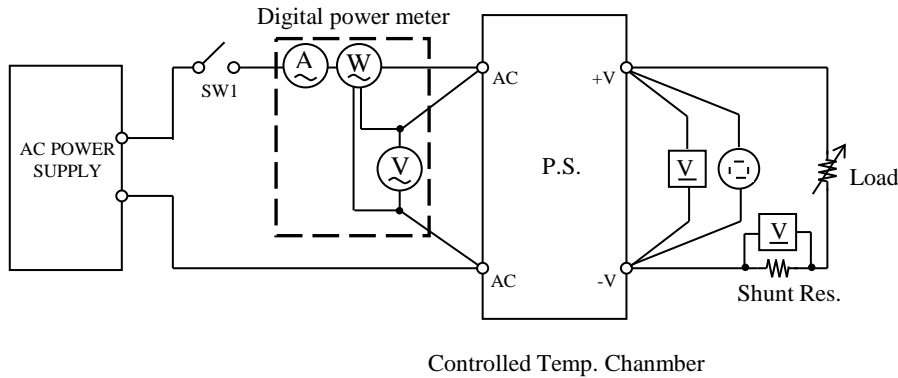

測定回路2 Circuit 2 used for determination

- 過渡応答(負荷急変) 特性 Dynamic load response characteristics

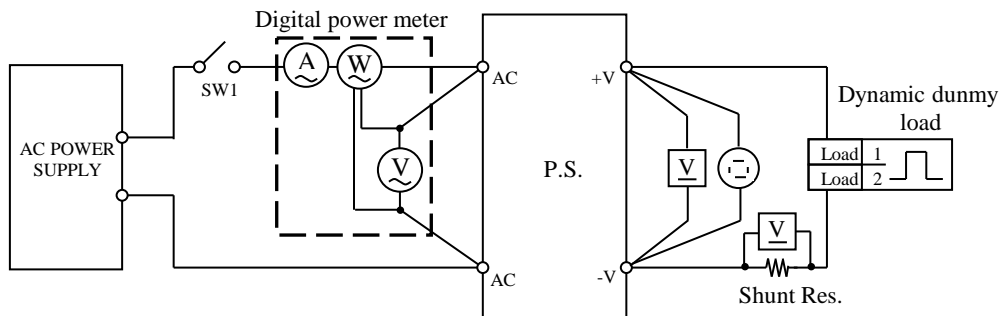

Output current waveform  
Iout 25% <=> 75%

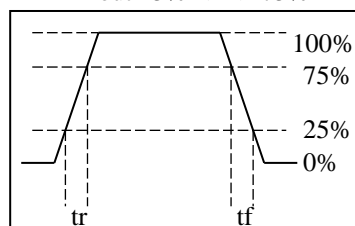

測定回路3 Circuit 3 used for determination

- 入力サージ電流(突入電流) 波形 Inrush current waveform

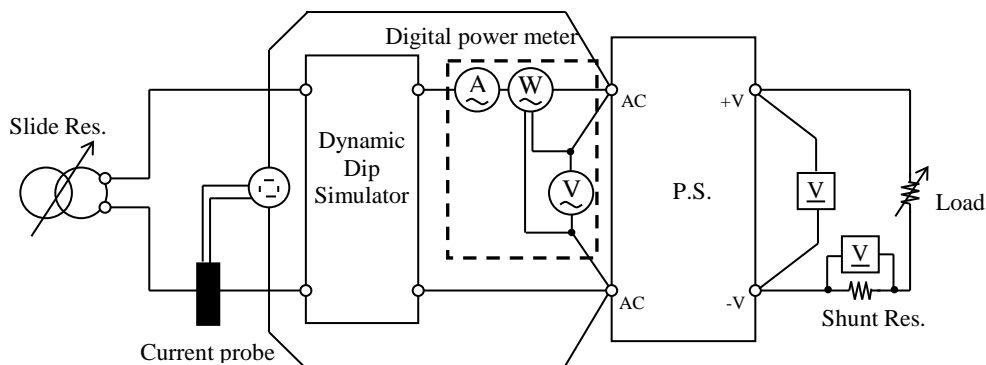



・ EMI 特性 Electro-Magnetic Interference characteristics

(a) 雑音端子電圧 (帰還ノイズ) Conducted Emission

CLASS I setup:

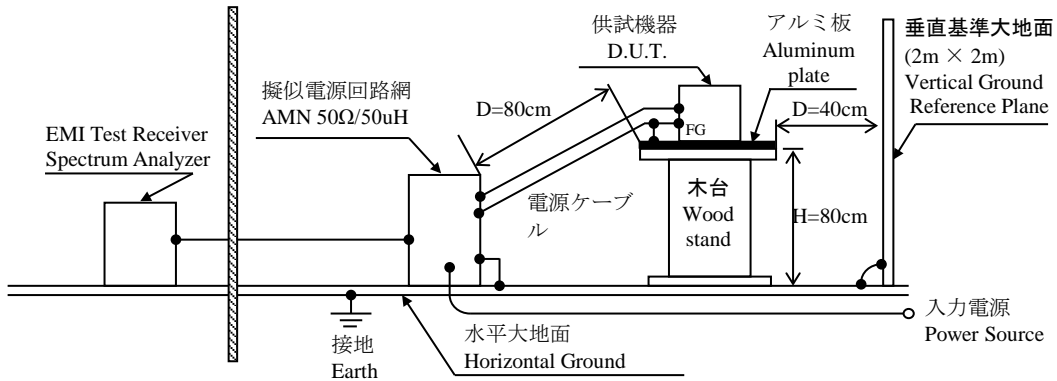

CLASS II setup:

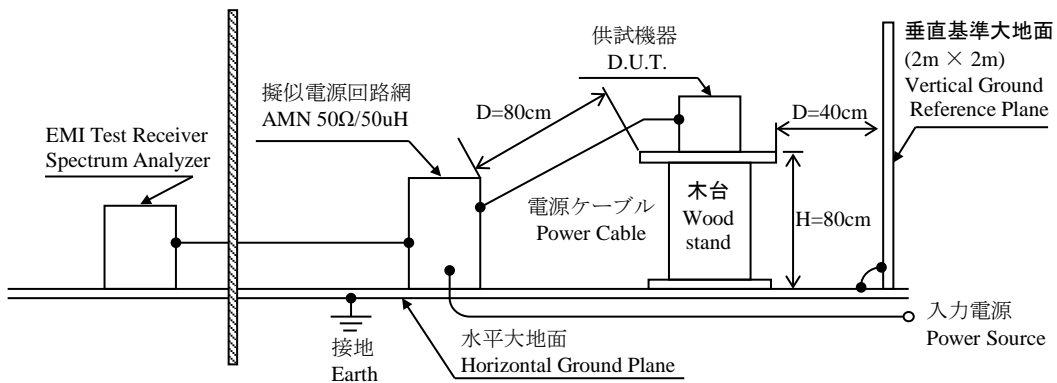

(b) 雑音電界強度 (放射ノイズ) Radiated Emission

CLASS I setup:

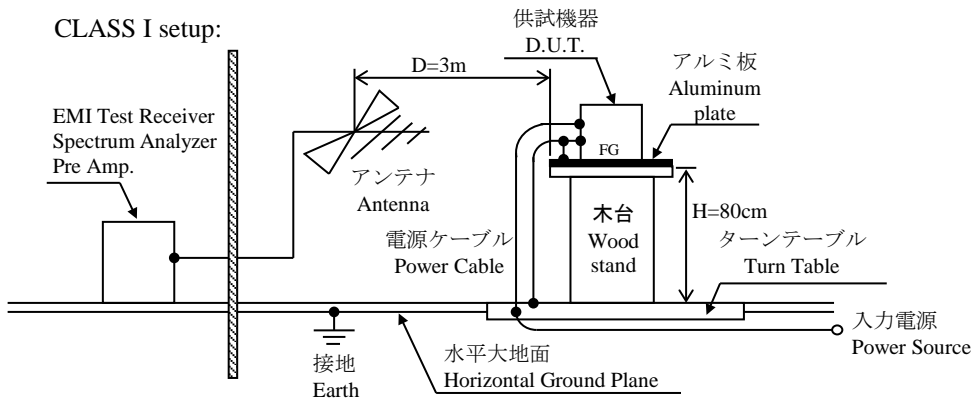

CLASS II setup:

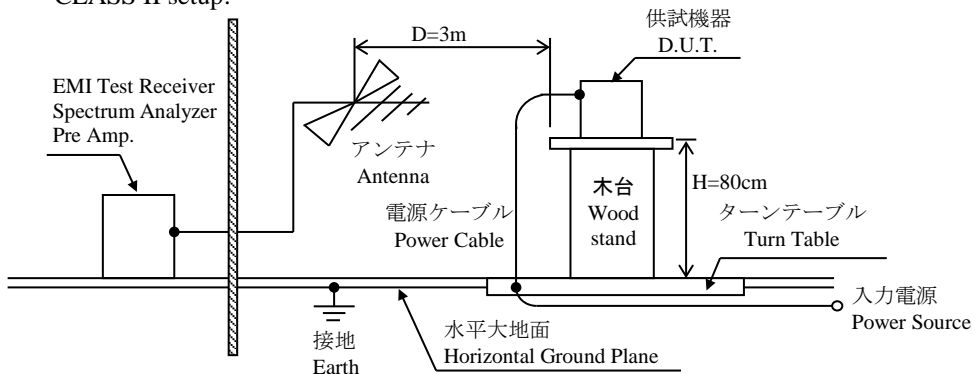

## 1.2 使用測定機器 List of equipment used

	EQUIPMENT USED	MANUFACTURER	MODEL NO.
1	DIGITAL STORAGE OSCILLOSCOPE	YOKOGAWA ELECT.	DL2054/DL9040
2	DIGITAL MULTIMETER	AGILENT	34970A
3	DIGITAL POWER METER	YOKOGAWA ELECT.	WT210
4	CURRENT PROBE	TEKTRONIX	63202
5	DC AMPERE METER	TEKTRONIX	P5100
6	DYNAMIC DUMMY LOAD	CHROMA	63030/63610/63640
7	AC SOURCE	KIKUSUI	PCR2000L
8	AC SOURCE	TAKAMISAWA	PSA-210
9	EARTH LEAKAGE CURRENT METER	SIMPSON	228
10	PATIENT LEAKAGE CURRENT METER	SIQ	SIQ16042
11	CONTROLLED TEMP. CHAMBER	TABAI-ESPEC	63203
12	EMI TEST RECEIVER	ROHDE & SCHWARZ	ESCI-03
13	LISN	ROHDE & SCHWARZ	ENV216
14	BICONICAL ANTENNA	EMCO	63208

## 2. 特性データ Characteristics

CUS30M

### 2.1 静特性 Steady state data

(1) 入力・負荷・温度変動／出力起動・遮断電圧

Regulation - line and load, Temperature drift / Start up voltage and Drop out voltage

**12V**  
(CUS30M-12)

#### 1. Regulation - line and load

Condition Ta : 25 °C

Iout \ Vin	85VAC	115VAC	230VAC	265VAC	line regulation	
0%	12.074V	12.074V	12.075V	12.075V	1mV	0.008%
50%	12.050V	12.050V	12.050V	12.051V	1mV	0.008%
100%	12.025V	12.026V	12.026V	12.026V	1mV	0.008%
load regulation	49mV	48mV	49mV	49mV		
	0.408%	0.400%	0.408%	0.408%		

#### 2. Temperature drift

Conditions Vin : 115 VAC

Iout : 100 %

Ta	-20°C	+25°C	+50°C	temperature stability	
Vout	11.989V	12.026V	12.023V	37mV	0.004%

#### 3. Start up voltage and Drop out voltage

Conditions Ta : 25 °C

Iout : 100 %

Start up voltage (Vin)	60.0Vac
Drop out voltage (Vin)	61.0Vac

**24V**  
(CUS30M-24)

#### 1. Regulation - line and load

Condition Ta : 25 °C

Iout \ Vin	85VAC	115VAC	230VAC	265VAC	line regulation	
0%	24.053V	24.054V	24.056V	24.058V	5mV	0.021%
50%	24.033V	24.033V	24.028V	24.026V	7mV	0.029%
100%	24.009V	24.003V	24.001V	24.001V	8mV	0.033%
load regulation	44mV	51mV	55mV	57mV		
	0.183%	0.212%	0.229%	0.237%		

#### 2. Temperature drift

Conditions Vin : 115 VAC

Iout : 100 %

Ta	-20°C	+25°C	+50°C	temperature stability	
Vout	23.981V	24.003V	23.972V	31mV	0.004%

#### 3. Start up voltage and Drop out voltage

Conditions Ta : 25 °C

Iout : 100 %

Start up voltage (Vin)	61.0Vac
Drop out voltage (Vin)	63.0Vac

## 2. 特性データ Characteristics

CUS30M

### 2.1 静特性 Steady state data

(1) 入力・負荷・温度変動／出力起動・遮断電圧

Regulation - line and load, Temperature drift / Start up voltage and Drop out voltage

**48V**  
(CUS30M-48)

#### 1. Regulation - line and load

Condition Ta : 25 °C

Iout \ Vin	85VAC	115VAC	230VAC	265VAC	line regulation	
0%	47.771V	47.772V	47.775V	47.779V	8mV	0.017%
50%	47.757V	47.759V	47.759V	47.758V	2mV	0.004%
100%	47.742V	47.744V	47.744V	47.742V	2mV	0.004%
load regulation	29mV	28mV	31mV	37mV		
	0.060%	0.058%	0.065%	0.077%		

#### 2. Temperature drift

Conditions Vin : 115 VAC

Iout : 100 %

Ta	-20°C	+25°C	+45°C	temperature stability	
Vout	47.529V	47.744V	47.810V	281mV	0.009%

#### 3. Start up voltage and Drop out voltage

Conditions Ta : 25 °C

Iout : 100 %

Start up voltage (Vin)	61.5Vac
Drop out voltage (Vin)	65.0Vac



(2) 効率対出力電流

Efficiency vs. Output current

Conditions Vin : 85 VAC -----  
 : 115 VAC -.-.-.-  
 : 230 VAC ————  
 : 265 VAC - - - - -  
 Ta : 25 °C

**12V**

(CUS30M-12)

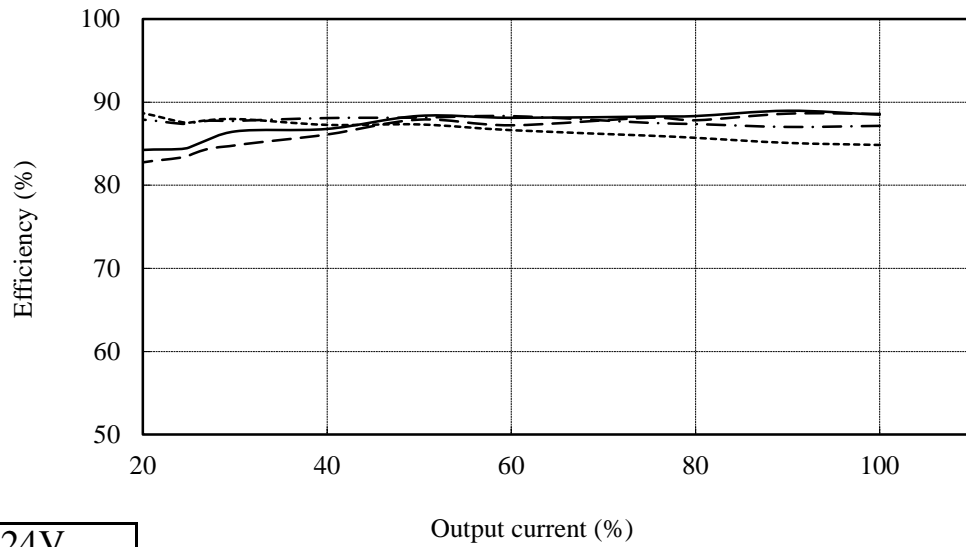

**24V**

(CUS30M-24)

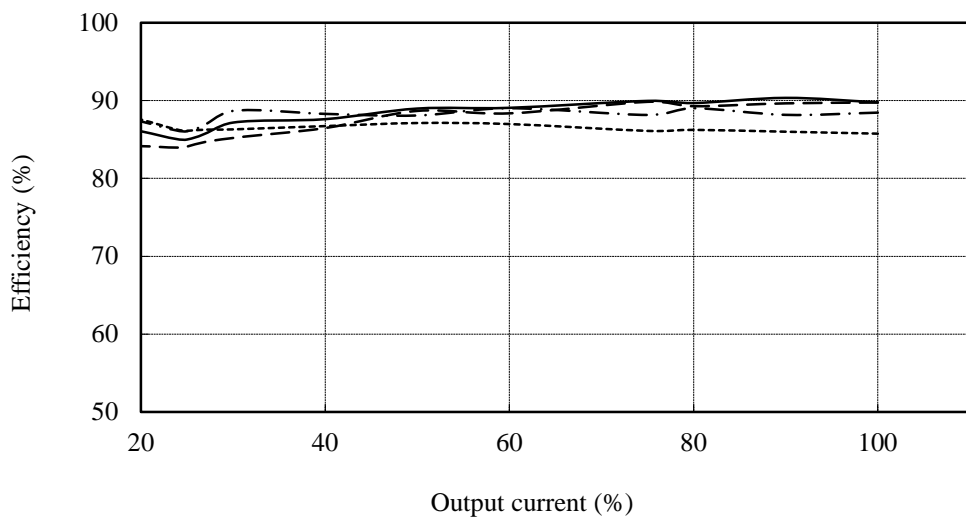

(2) 効率対出力電流  
Efficiency vs. Output current

Conditions Vin : 85 VAC -----  
                  : 115 VAC -.-.-.-  
                  : 230 VAC ————  
                  : 265 VAC - - - -  
                  Ta : 25 °C

48V

(CUS30M-48)

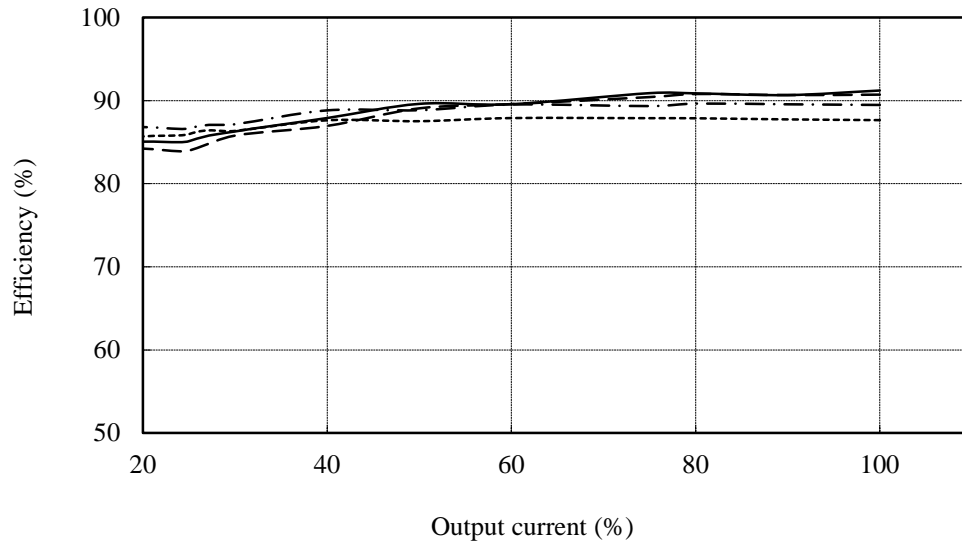

(3) 入力電流対出力電流  
Input current vs. Output current

Conditions Vin : 85 VAC -----  
 : 115 VAC -.-.-.-  
 : 230 VAC ————  
 : 265 VAC - - - - -  
 Ta : 25 °C

**12V**  
(CUS30M-12)

Io: 100%

Vin	Input current
85Vac	0.693A
115Vac	0.554A
230Vac	0.344A
265Vac	0.311A

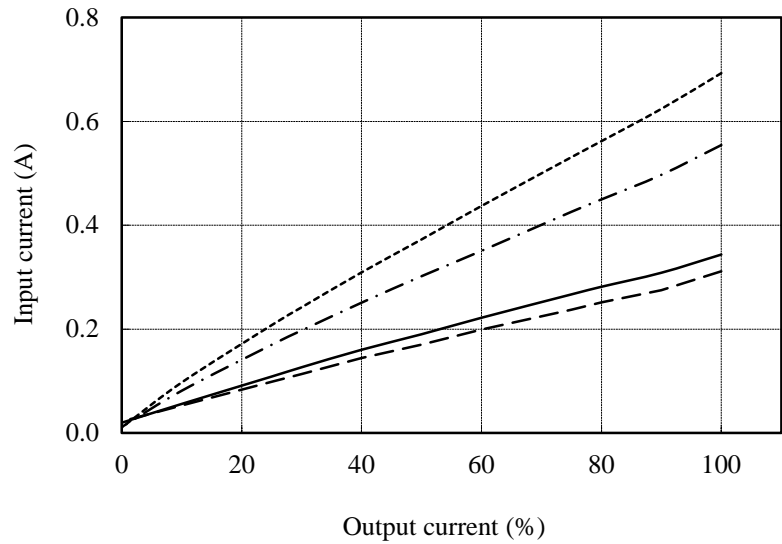

**24V**  
(CUS30M-24)

Io: 100%

Vin	Input current
85Vac	0.678A
115Vac	0.550A
230Vac	0.340A
265Vac	0.305A

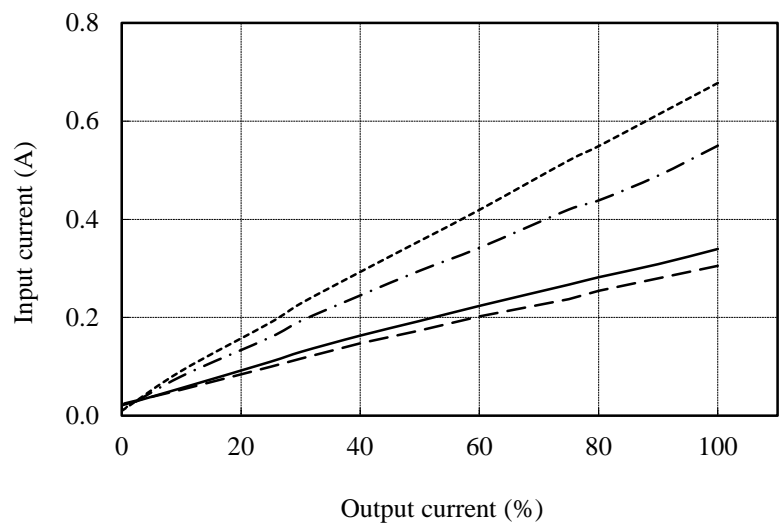

(3) 入力電流対出力電流  
Input current vs. Output current

Conditions Vin : 85 VAC -----  
 : 115 VAC -.-.-.-  
 : 230 VAC ————  
 : 265 VAC - - - - -  
 Ta : 25 °C

48V

  
 (CUS30M-48)

Io: 100%

Vin	Input current
85Vac	0.663A
115Vac	0.524A
230Vac	0.318A
265Vac	0.290A

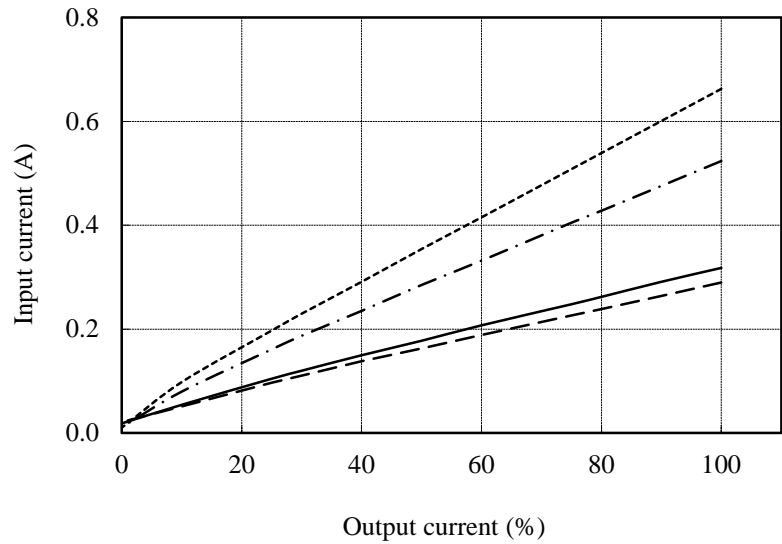

(4) 入力電力対出力電流  
Input power vs. Output current

Conditions Vin : 85 VAC -----  
 : 115 VAC - - - -  
 : 230 VAC ———  
 : 265 VAC - - - -  
 Ta : 25 °C

**12V**  
(CUS30M-12)

Io: 100%

Vin	Input power
85Vac	35.41W
115Vac	34.48W
230Vac	33.96W
265Vac	33.92W

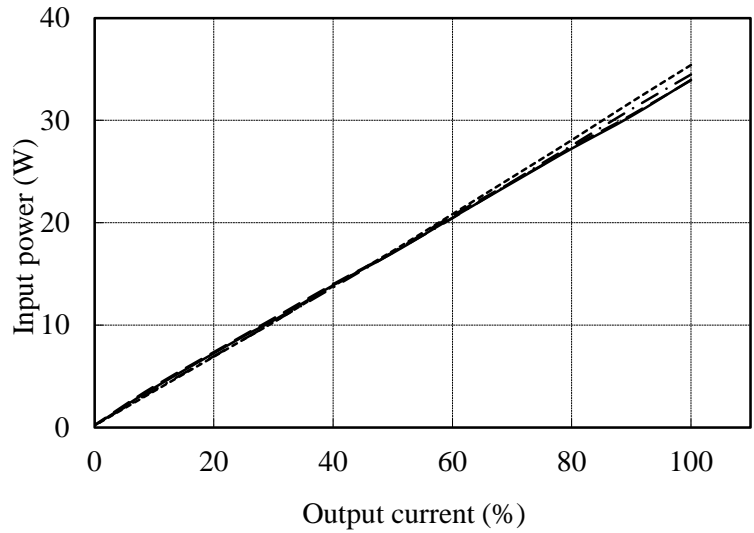

**24V**  
(CUS30M-24)

Io: 100%

Vin	Input power
85Vac	34.86W
115Vac	33.79W
230Vac	33.29W
265Vac	33.30W

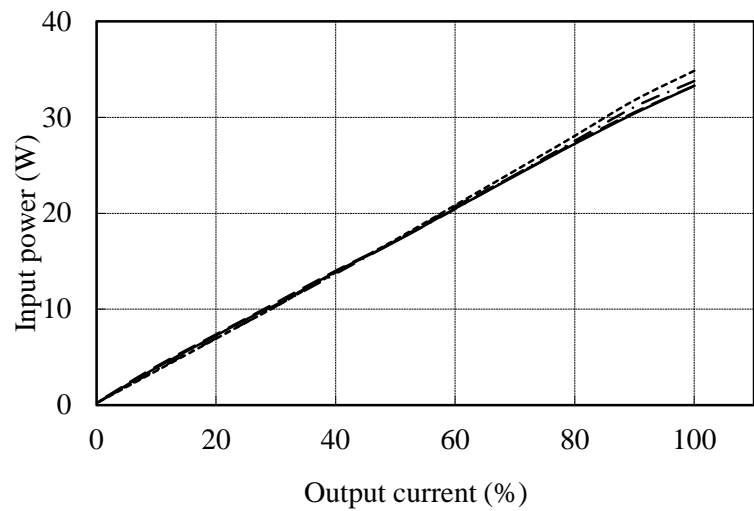

(4) 入力電力対出力電流  
Input power vs. Output current

Conditions Vin : 85 VAC -----  
 : 115 VAC -.-.-.  
 : 230 VAC ———  
 : 265 VAC - - - -  
 Ta : 25 °C

48V  
(CUS30M-48)

Io: 100%

Vin	Input power
85Vac	34.31W
115Vac	33.61W
230Vac	32.97W
265Vac	33.15W

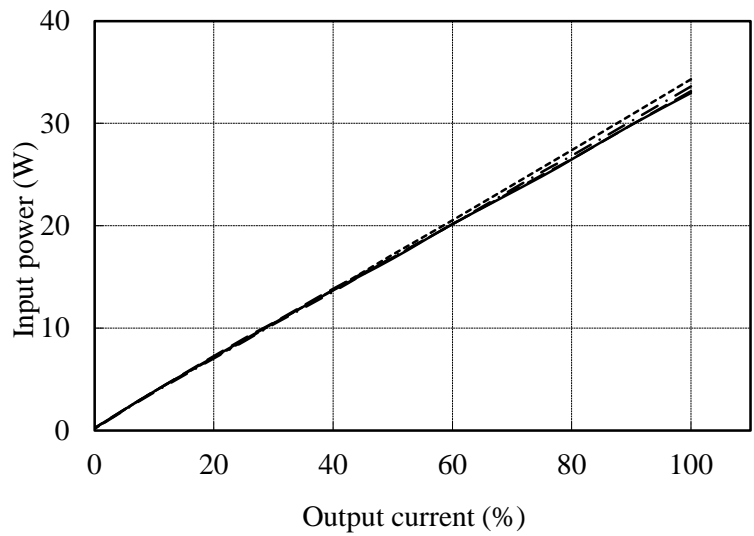

2.2 過電流保護特性

Over current protection (OCP) characteristics

Conditions Vin : 85 VAC -----  
 115 VAC -.-.-.-  
 230 VAC ————  
 265 VAC - - - -  
 Ta : 25 °C

**12V**  
 (CUS30M-12)

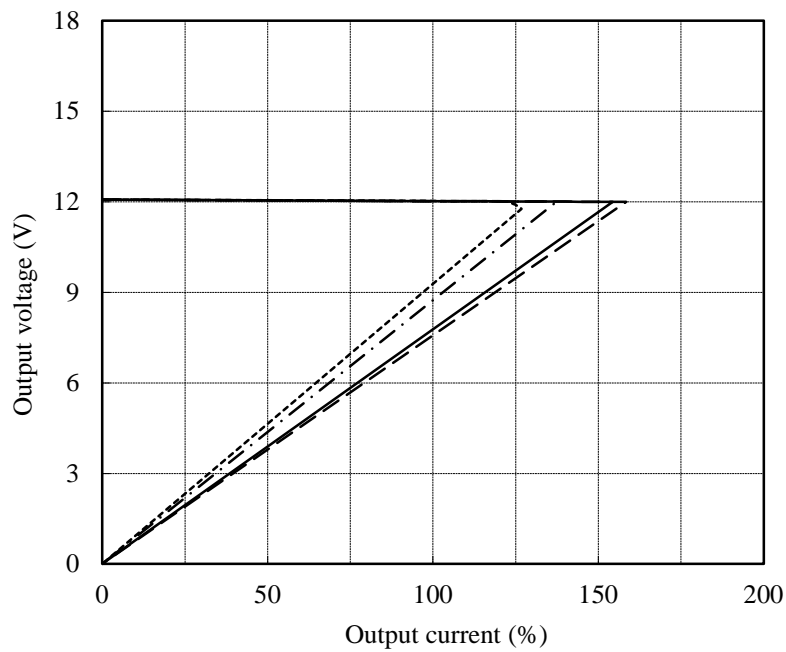

**24V**  
 (CUS30M-24)

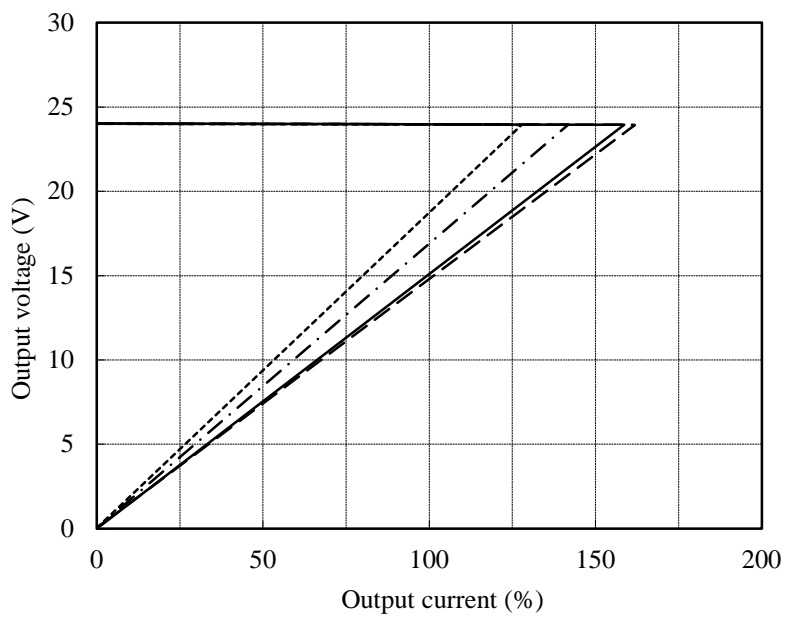

2.2 過電流保護特性

Over current protection (OCP) characteristics

Conditions Vin : 85 VAC -----  
 115 VAC -.-.-.-  
 230 VAC ————  
 265 VAC - - - -  
 Ta : 25 °C

**48V**  
 (CUS30M-48)

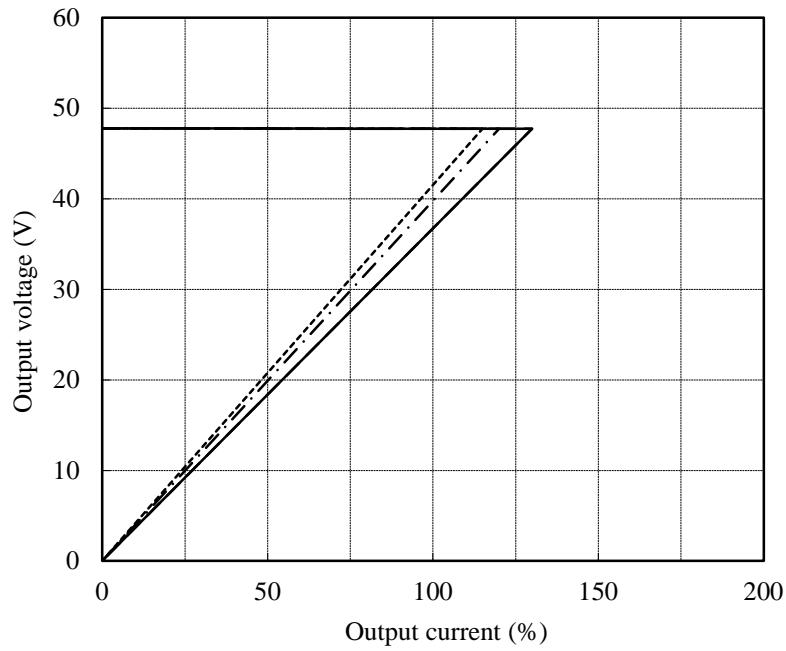



2.3 過電圧保護特性

Over voltage protection (OVP) characteristics

12V  
(CUS30M-12)

Conditions Vin : 115 VAC  
Iout : 0 %  
Ta : 25 °C

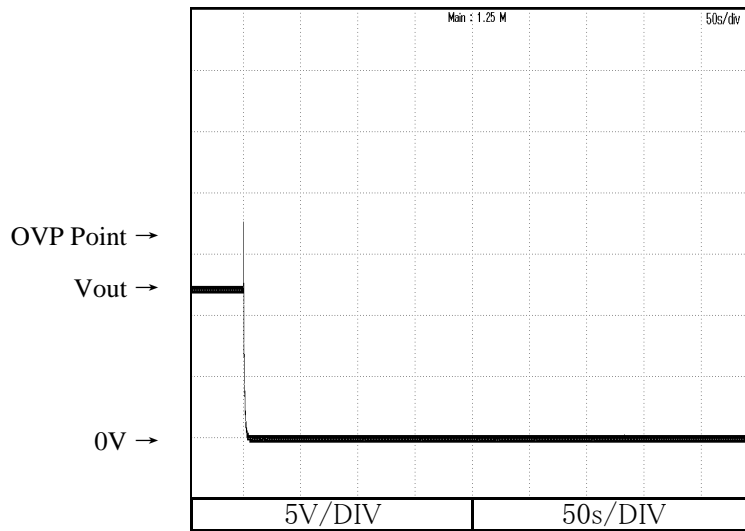

Conditions Vin : 230 VAC  
Iout : 0 %  
Ta : 25 °C

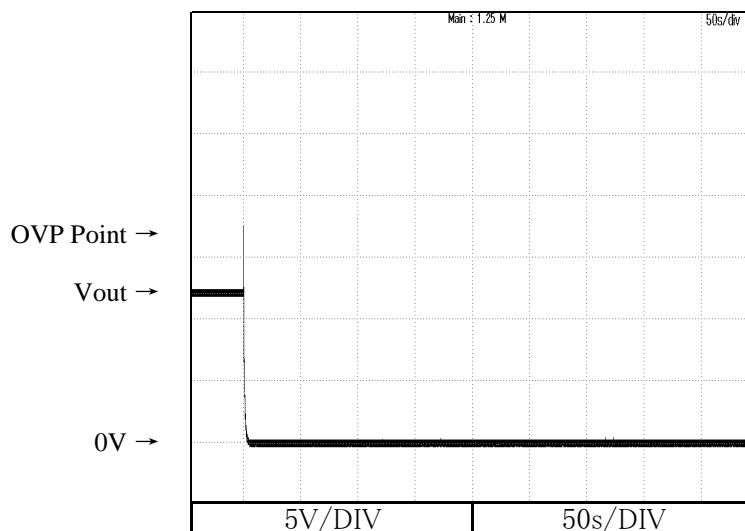

2.3 過電圧保護特性

Over voltage protection (OVP) characteristics

24V  
(CUS30M-24)

Conditions Vin : 115 VAC  
Iout : 0 %  
Ta : 25 °C

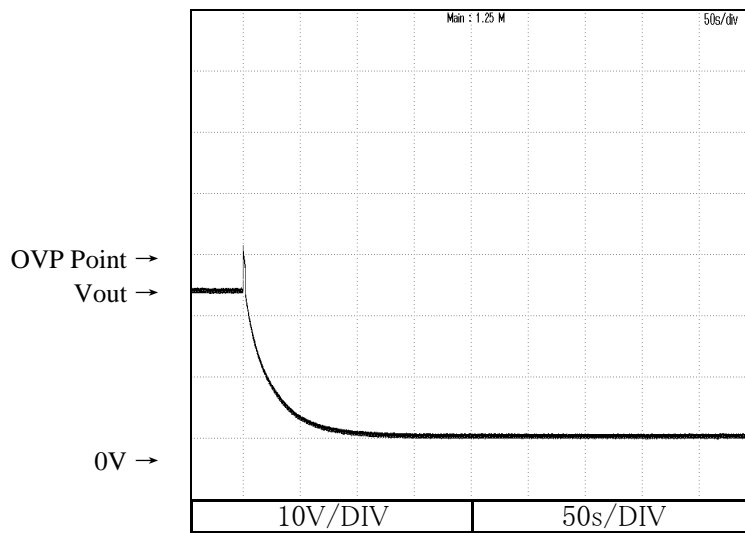

Conditions Vin : 230 VAC  
Iout : 0 %  
Ta : 25 °C

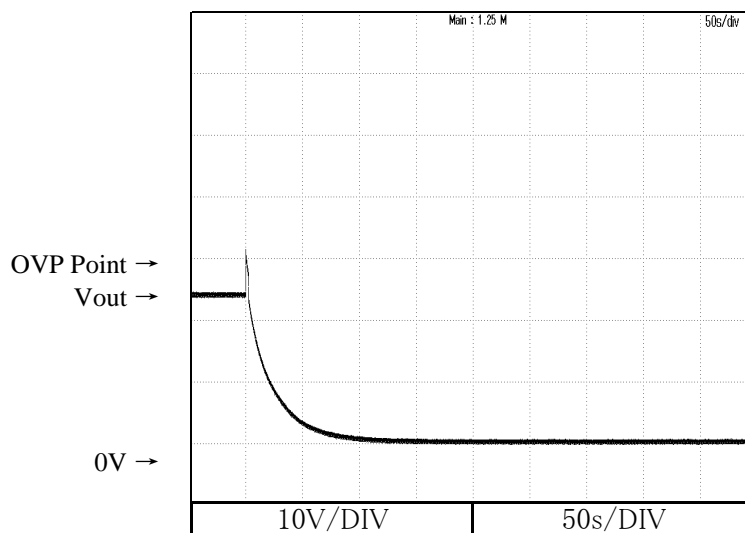

2.3 過電圧保護特性

Over voltage protection (OVP) characteristics

48V  
(CUS30M-48)

Conditions Vin : 115 VAC  
Iout : 0 %  
Ta : 25 °C

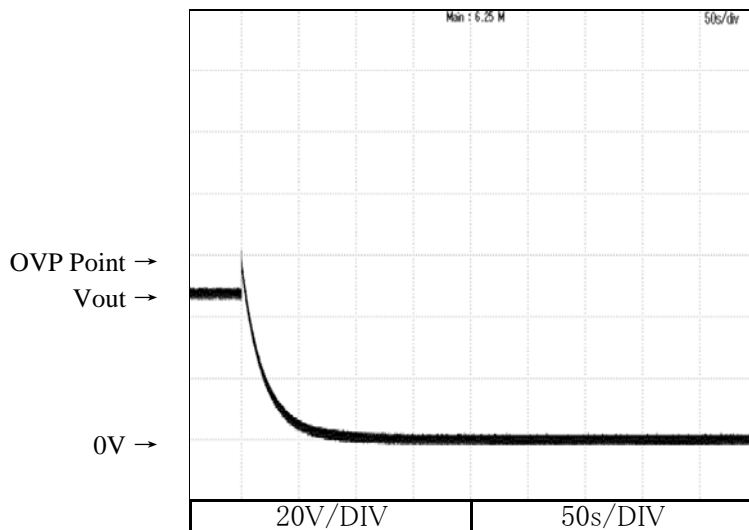

Conditions Vin : 230 VAC  
Iout : 0 %  
Ta : 25 °C

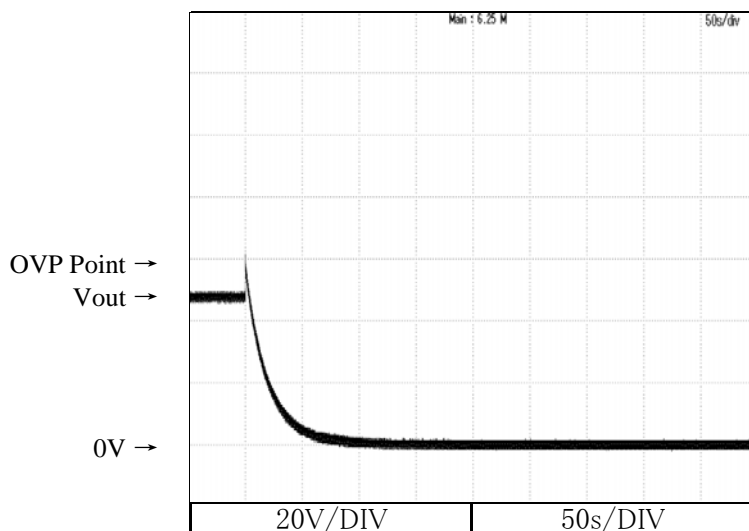

2.4 出力立ち上がり特性  
Output rise characteristics

CUS30M

Conditions Vin : 85 VAC (A)  
115 VAC (B)  
230 VAC (C)  
265 VAC (D)  
Ta : 25 °C

12V  
(CUS30M-12)

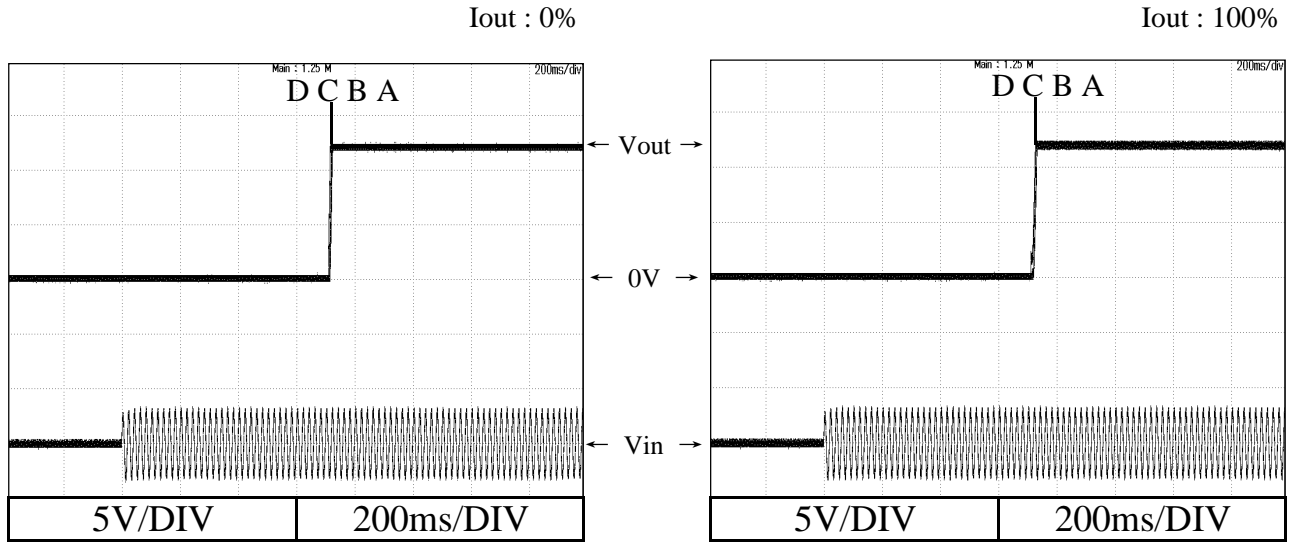

24V  
(CUS30M-24)

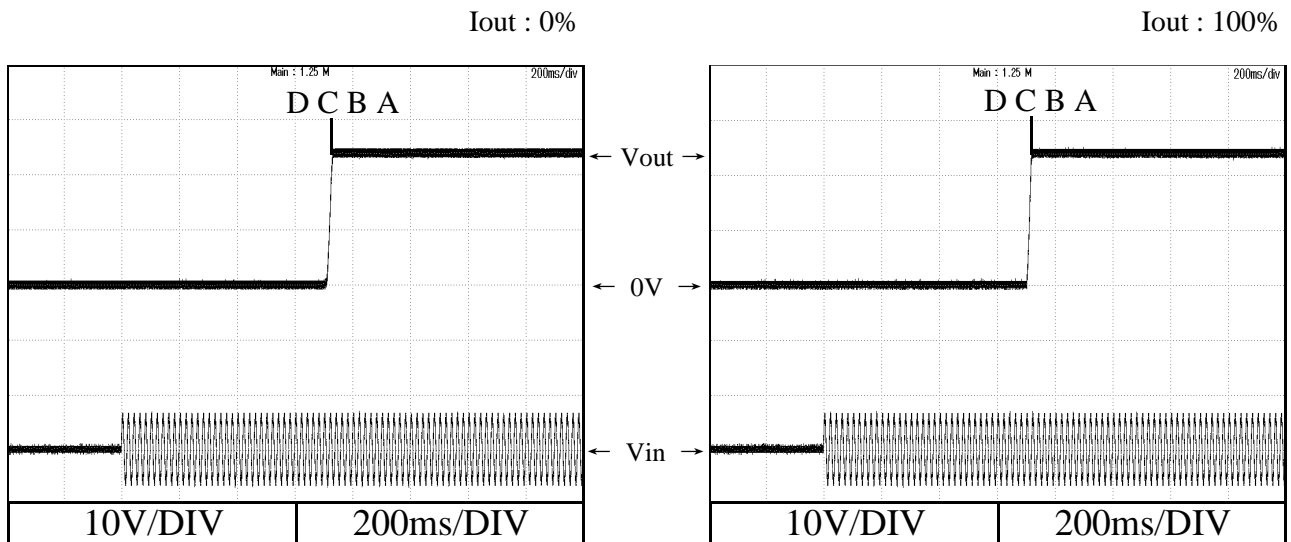

2.4 出力立ち上がり特性  
Output rise characteristics

# CUS30M

Conditions Vin : 85 VAC (A)  
115 VAC (B)  
230 VAC (C)  
265 VAC (D)  
Ta : 25 °C

48V  
(CUS30M-48)

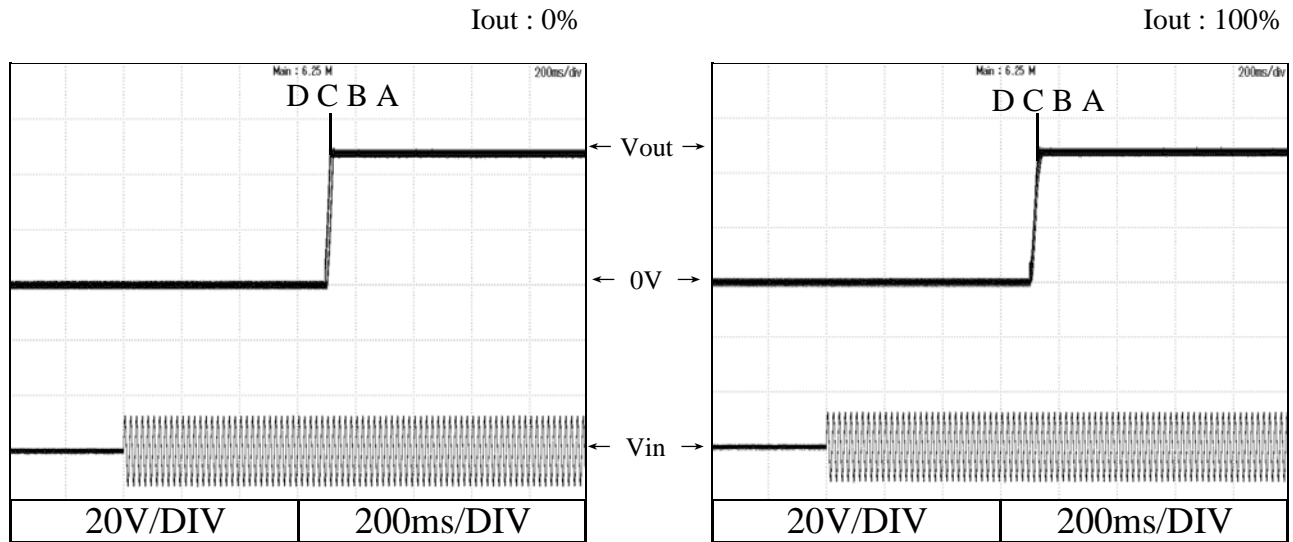

2.5 出力立ち下がり特性  
Output fall characteristics

CUS30M

Conditions Vin : 85 VAC (A)  
115 VAC (B)  
230 VAC (C)  
265 VAC (D)  
Ta : 25 °C

12V  
(CUS30M-12)

Iout : 0%

Iout : 100%

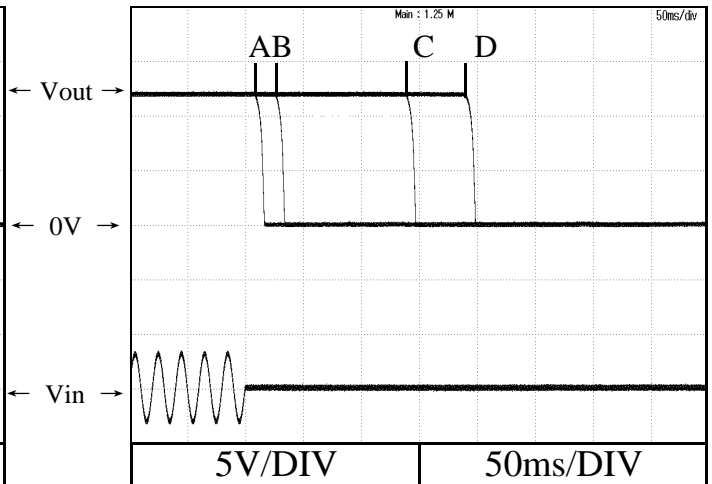
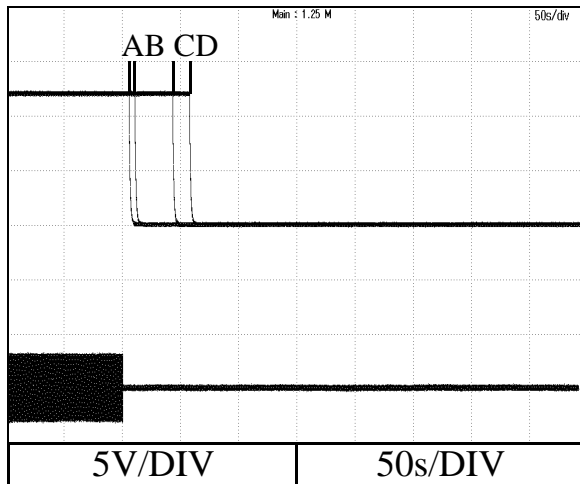

24V  
(CUS30M-24)

Iout : 0%

Iout : 100%

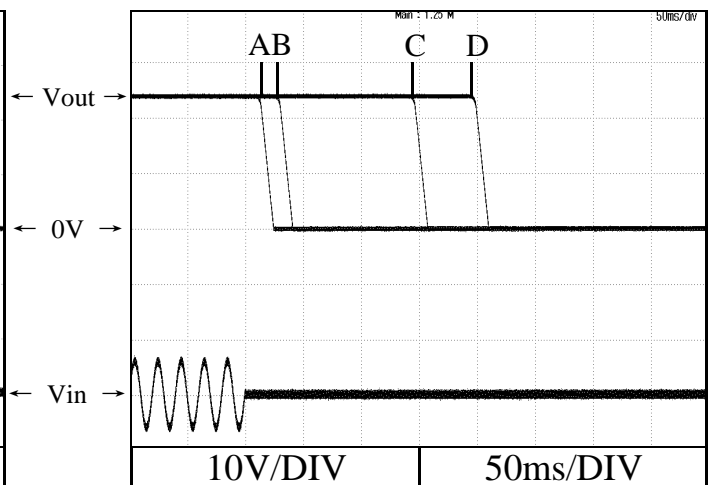
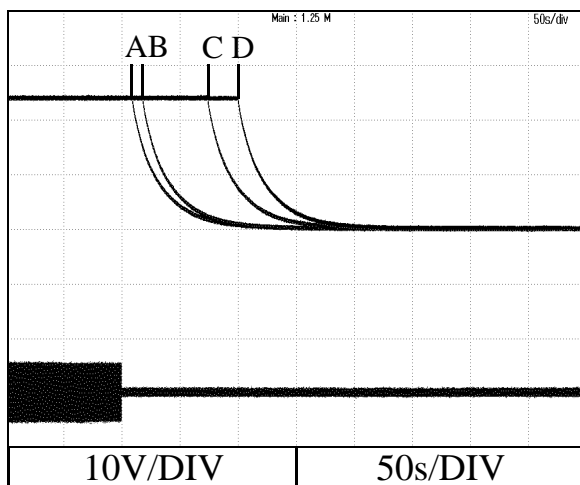

2.5 出力立ち下がり特性  
Output fall characteristics

CUS30M

Conditions Vin : 85 VAC (A)  
115 VAC (B)  
230 VAC (C)  
265 VAC (D)  
Ta : 25 °C

48V

(CUS30M-48)

Iout : 0%

Iout : 100%

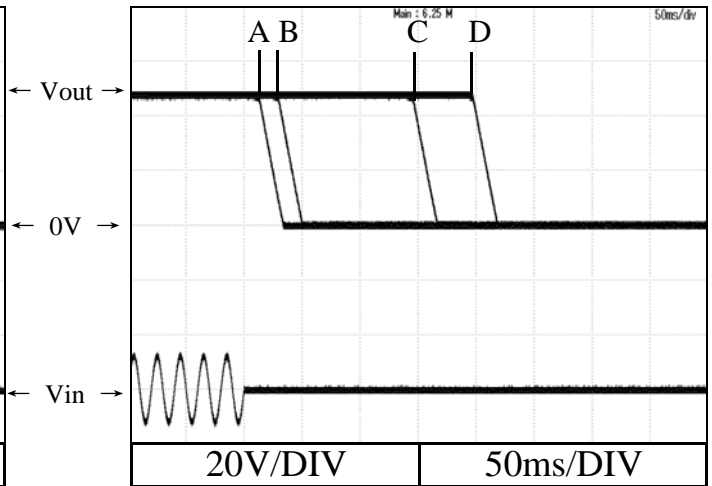
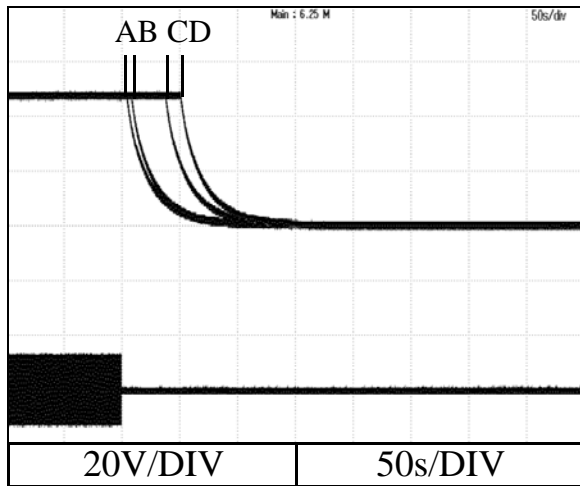

2.6 出力保持時間特性  
Hold up time characteristics

Conditions Vin : 115 VAC -----  
230 VAC ———  
Ta : 25 °C

**12V**  
(CUS30M-12)

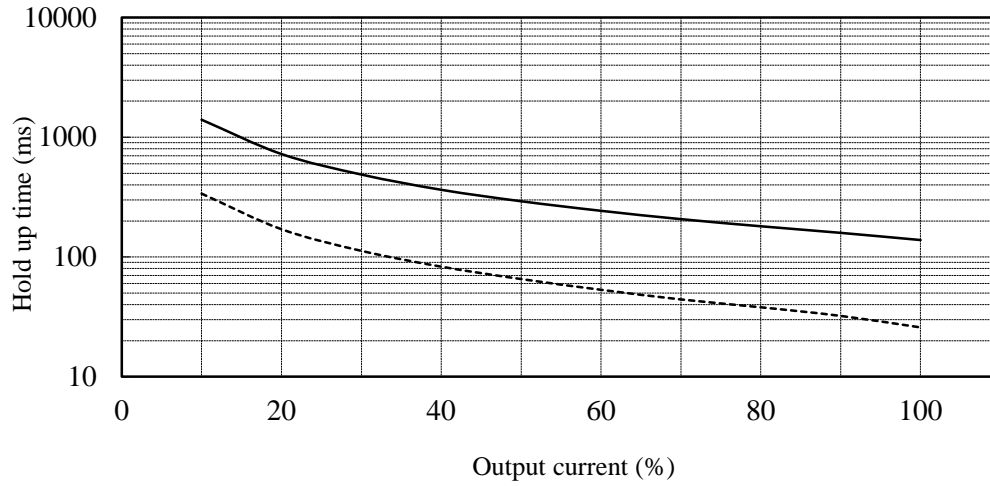

**24V**  
(CUS30M-24)

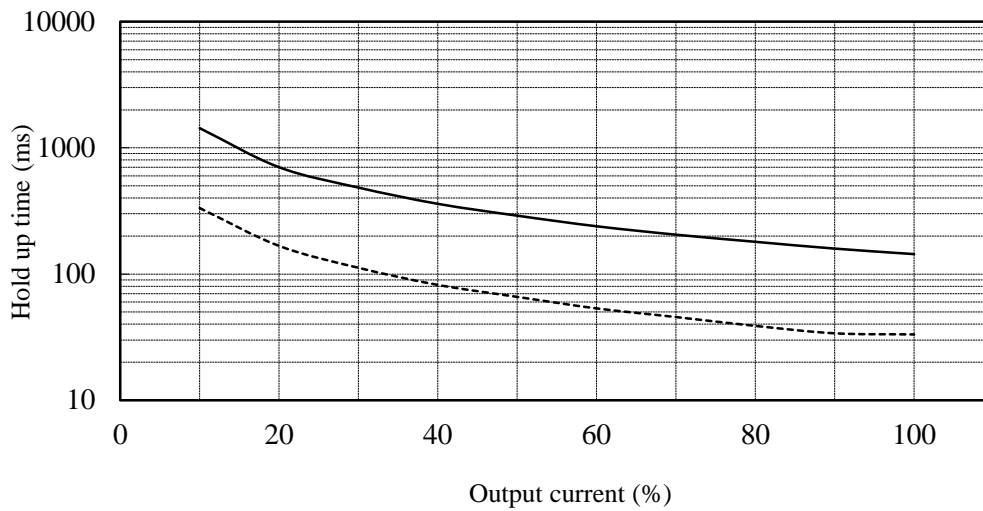



2.6 出力保持時間特性  
Hold up time characteristics

Conditions Vin : 115 VAC -----  
230 VAC ———  
Ta : 25 °C

48V  
(CUS30M-48)

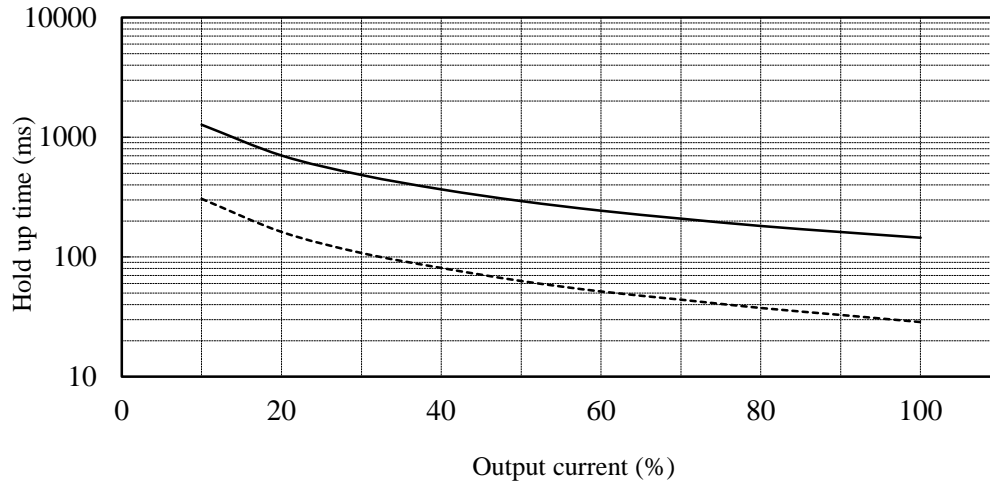

## 2.7 過渡応答（負荷急変）特性 Dynamic load response characteristics

Conditions Vin : 115 VAC  
Iout : 25 % ↔ 75 %  
(tr = tf = 50us)  
Ta : 25 °C

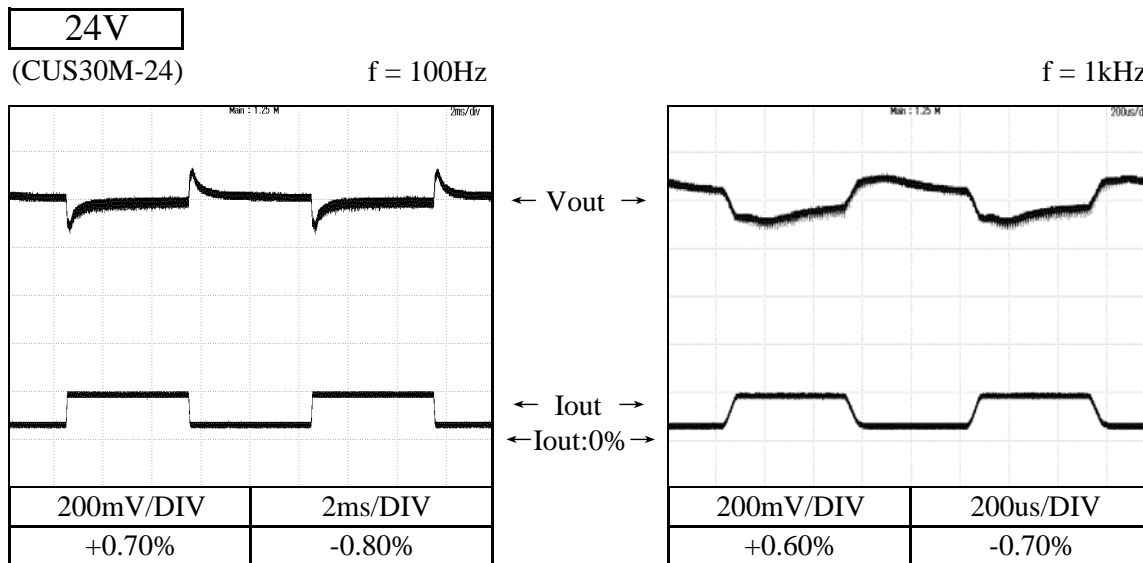
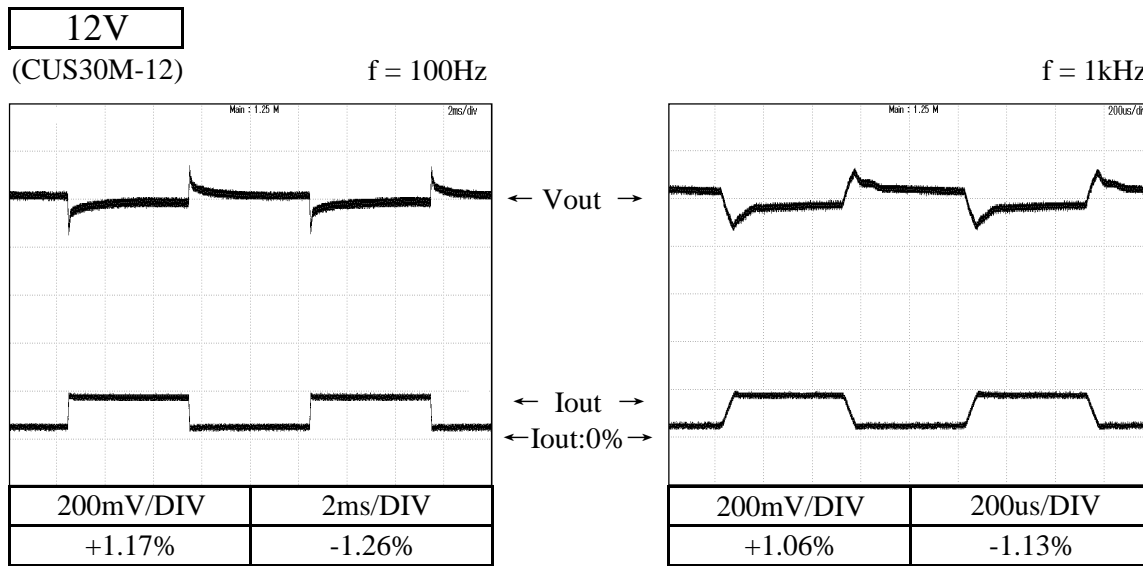

# CUS30M

## 2.7 過渡応答（負荷急変）特性

Dynamic load response characteristics

Conditions Vin : 115 VAC  
 Iout : 25 % ↔ 75 %  
 (tr = tf = 50us)  
 Ta : 25 °C

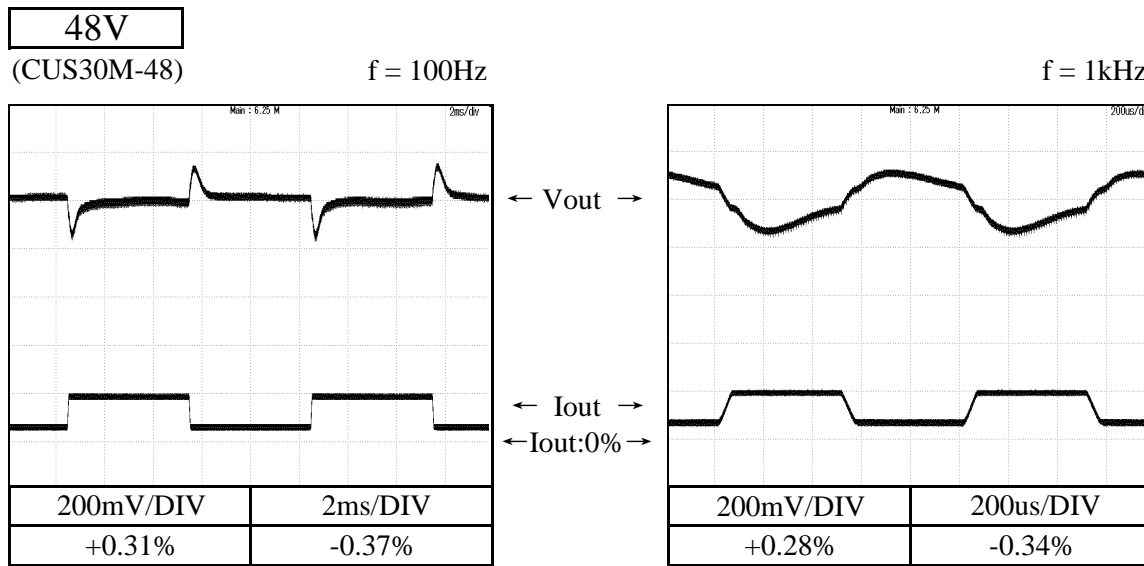

## 2.7 過渡応答（負荷急変）特性 Dynamic load response characteristics

Conditions Vin : 230 VAC  
 Iout : 25 % ↔ 75 %  
 (tr = tf = 50us)  
 Ta : 25 °C

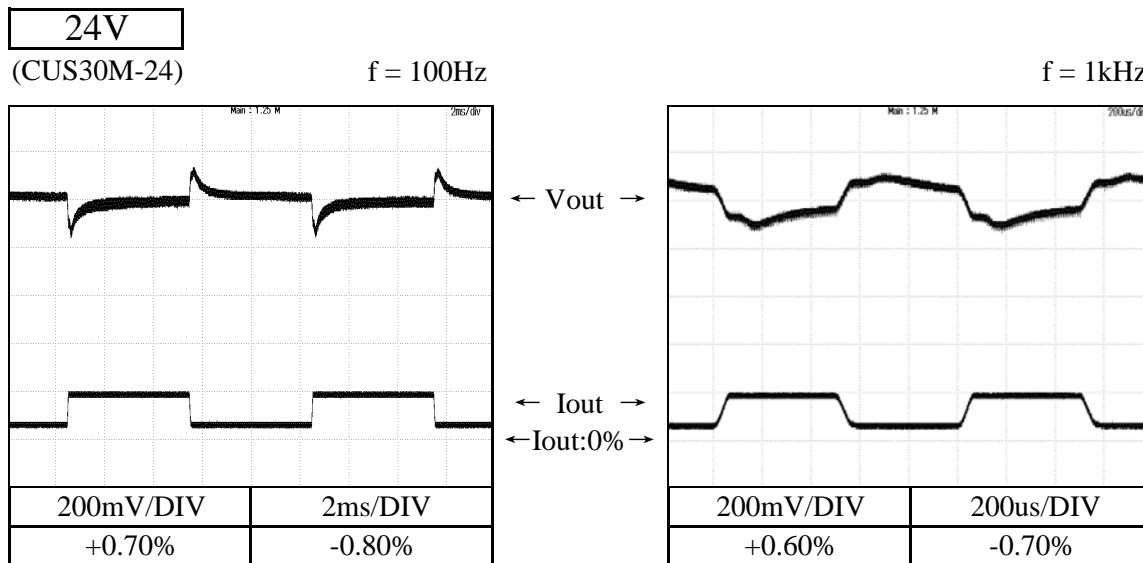
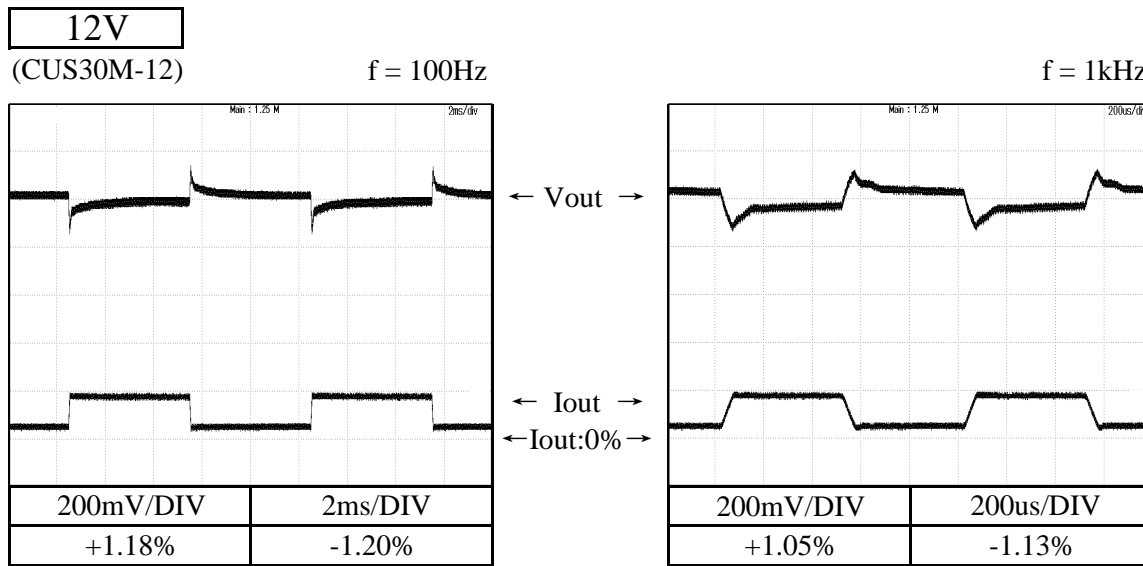

# CUS30M

## 2.7 過渡応答（負荷急変）特性

Dynamic load response characteristics

Conditions Vin : 230 VAC  
 Iout : 25 % ↔ 75 %  
 (tr = tf = 50us)  
 Ta : 25 °C

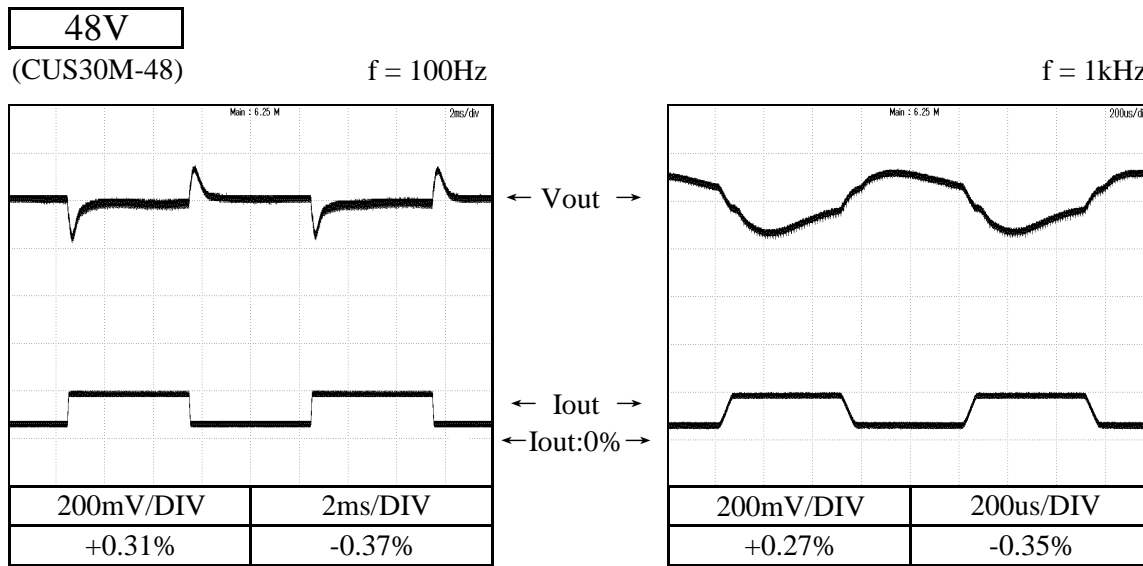

2.8 入力電圧瞬停特性

Response to brown out characteristics

Conditions Vin : 115 VAC  
Iout : 100 %  
Ta : 25 °C

**12V**  
(CUS30M-12)

A = 25ms  
B = 32ms  
C = 40ms

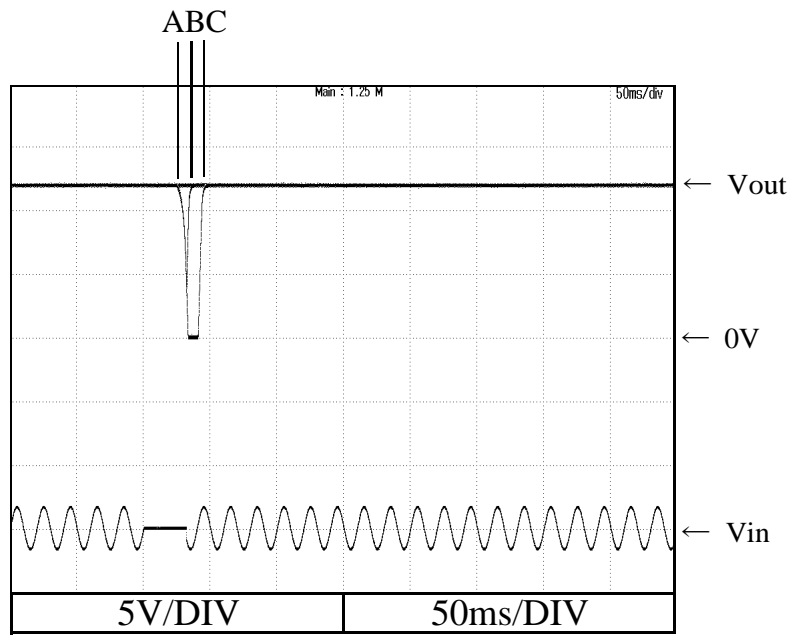

**24V**  
(CUS30M-24)

A=27ms  
B=32ms  
C=47ms

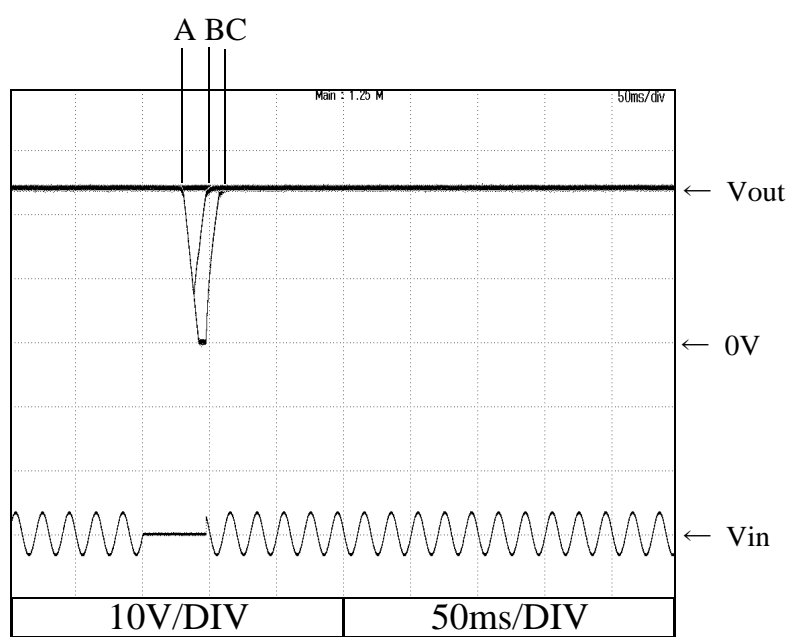

2.8 入力電圧瞬停特性

Response to brown out characteristics

Conditions Vin : 115 VAC  
Iout : 100 %  
Ta : 25 °C

48V  
(CUS30M-48)

A = 18ms  
B = 24ms  
C = 30ms

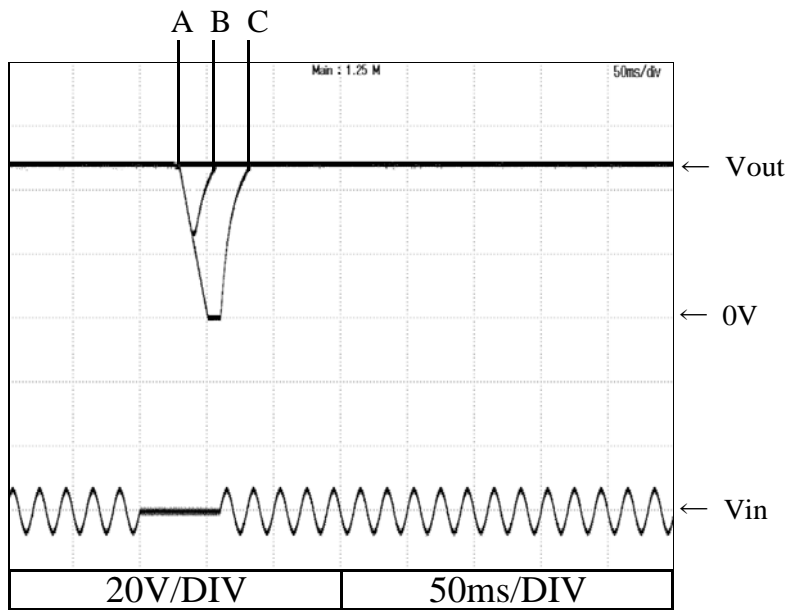

2.8 入力電圧瞬停特性

Response to brown out characteristics

Conditions Vin : 230 VAC  
Iout : 100 %  
Ta : 25 °C

**12V**  
(CUS30M-12)

A = 138ms  
B = 147ms  
C = 155ms

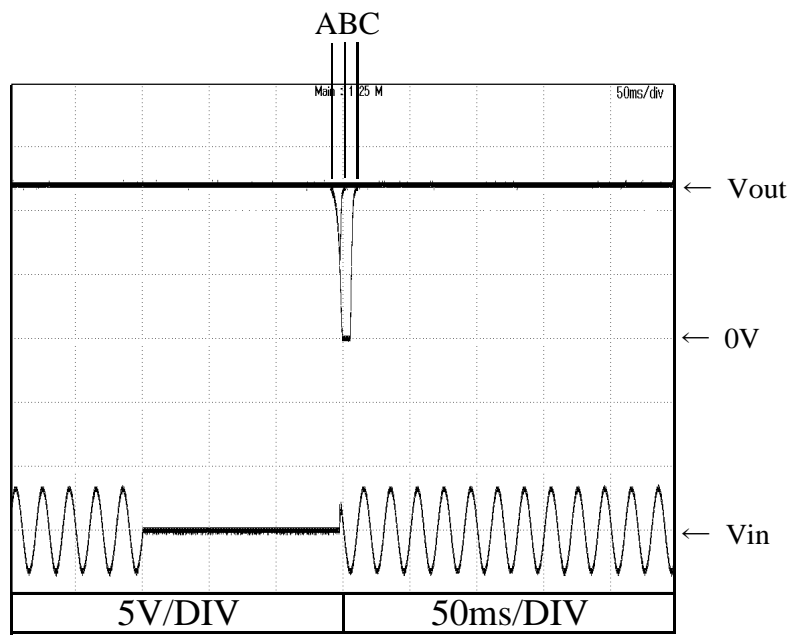

**24V**  
(CUS30M-24)

A = 140ms  
B = 148ms  
C = 162ms

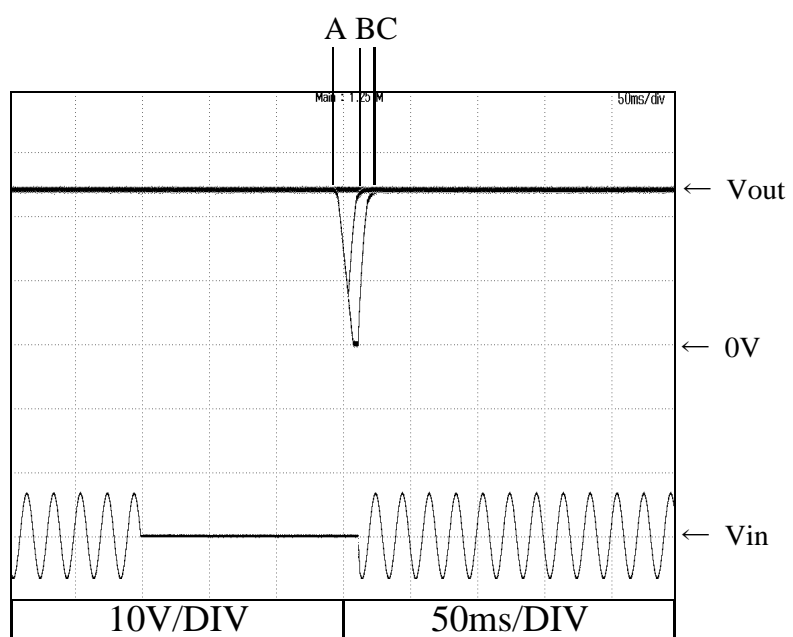



2.8 入力電圧瞬停特性

Response to brown out characteristics

Conditions Vin : 230 VAC  
Iout : 100 %  
Ta : 25 °C

48V  
(CUS30M-48)

A = 109ms  
B = 114ms  
C = 121ms

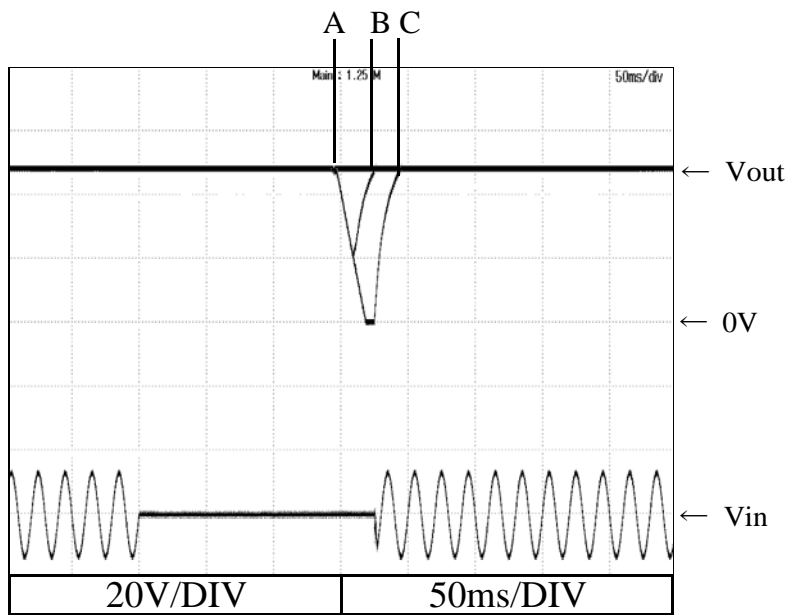

2.9 入力サージ電流（突入電流）波形  
Inrush current waveform

12V  
(CUS30M-12)

Conditions Vin : 115 VAC  
Iout : 100 %  
Ta : 25 °C  
Cold start

Switch on phase angle of input AC voltage  
 $\Phi=0^\circ$

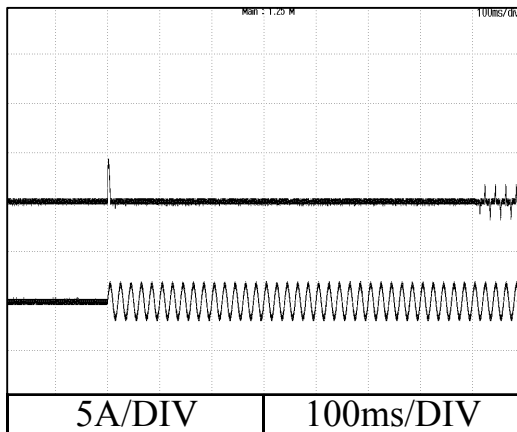

Switch on phase angle of input AC voltage  
 $\Phi=90^\circ$

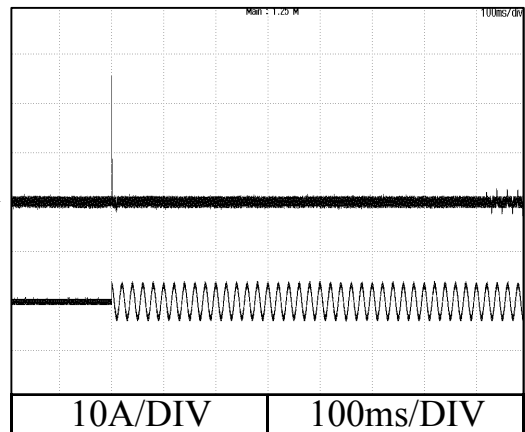

Conditions Vin : 230 VAC  
Iout : 100 %  
Ta : 25 °C  
Cold start

Switch on phase angle of input AC voltage  
 $\Phi=0^\circ$

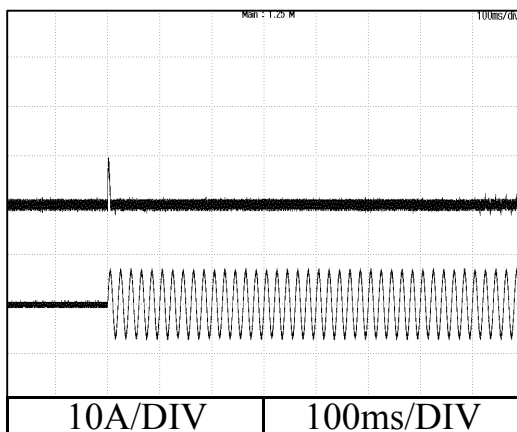

Switch on phase angle of input AC voltage  
 $\Phi=90^\circ$

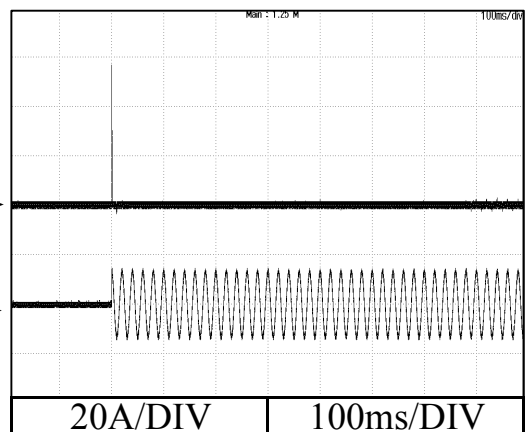

2.9 入力サージ電流（突入電流）波形  
Inrush current waveform

24V  
(CUS30M-24)

Conditions Vin : 115 VAC  
Iout : 100 %  
Ta : 25 °C  
Cold start

Switch on phase angle of input AC voltage  
 $\Phi=0^\circ$

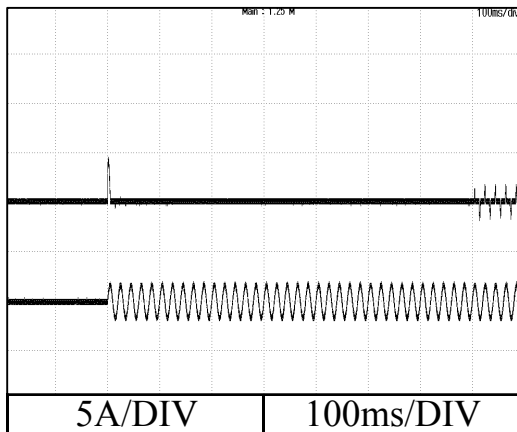

Switch on phase angle of input AC voltage  
 $\Phi=90^\circ$

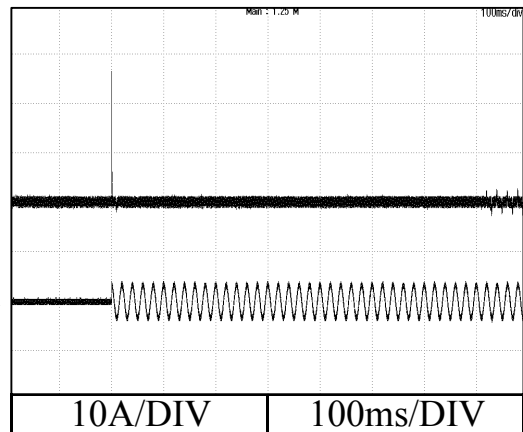

Conditions Vin : 230 VAC  
Iout : 100 %  
Ta : 25 °C  
Cold start

Switch on phase angle of input AC voltage  
 $\Phi=0^\circ$

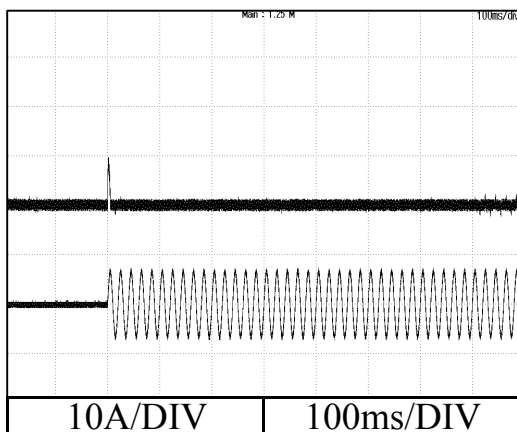

Switch on phase angle of input AC voltage  
 $\Phi=90^\circ$

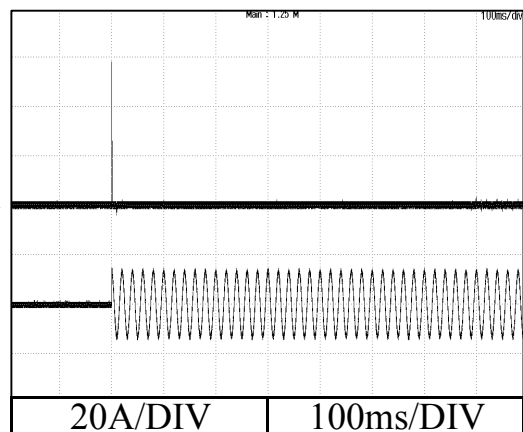

2.9 入力サージ電流（突入電流）波形  
Inrush current waveform

48V  
(CUS30M-48)

Conditions Vin : 115 VAC  
Iout : 100 %  
Ta : 25 °C  
Cold start

Switch on phase angle of input AC voltage  
 $\Phi=0^\circ$

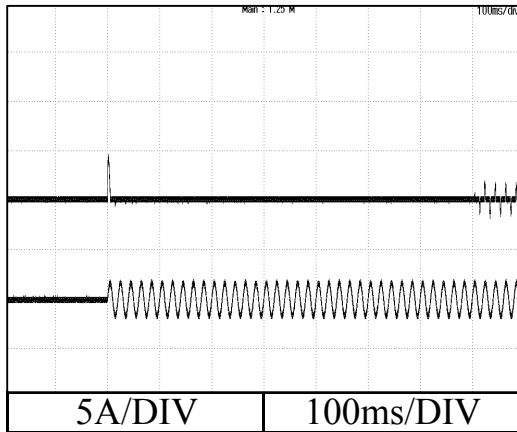

Switch on phase angle of input AC voltage  
 $\Phi=90^\circ$

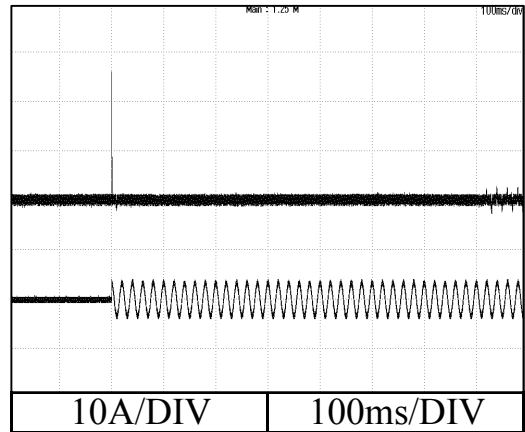

Conditions Vin : 230 VAC  
Iout : 100 %  
Ta : 25 °C  
Cold start

Switch on phase angle of input AC voltage  
 $\Phi=0^\circ$

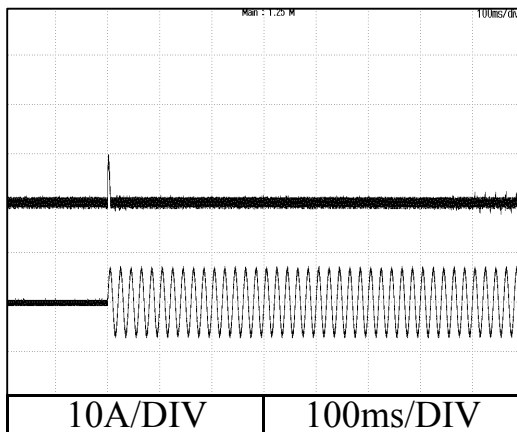

Switch on phase angle of input AC voltage  
 $\Phi=90^\circ$

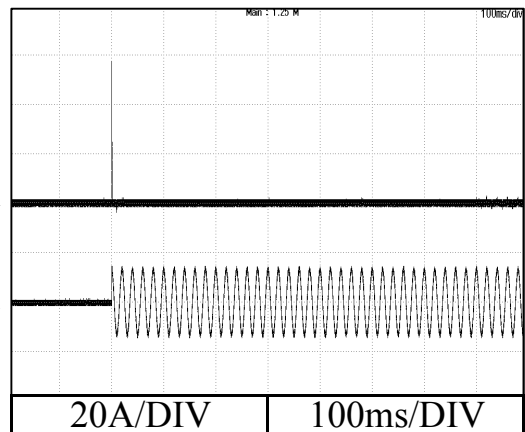

2.10 リーク電流特性  
Leakage current characteristics

CUS30M

Conditions Iout : 0 % -----  
                  100 % ————  
                  Ta : 25 °C  
Equipment used : SIQ16042

12V

  
(CUS30M-12)

Patient leakage current of CLASS I equipment

f : 50 Hz

Normal condition

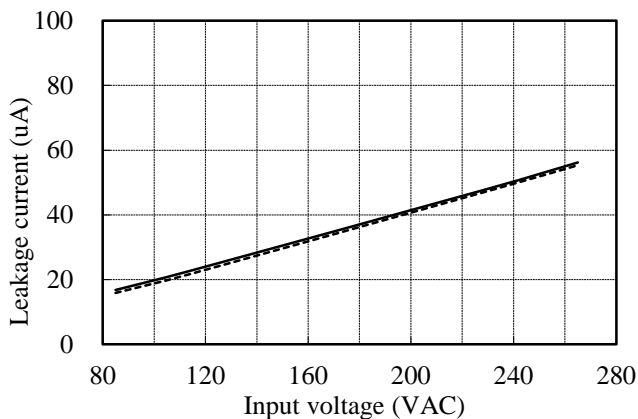

Single fault condition(Open FG)

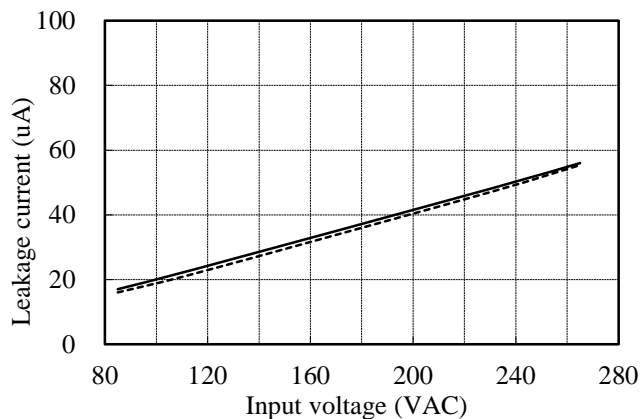

f : 60 Hz

Normal condition

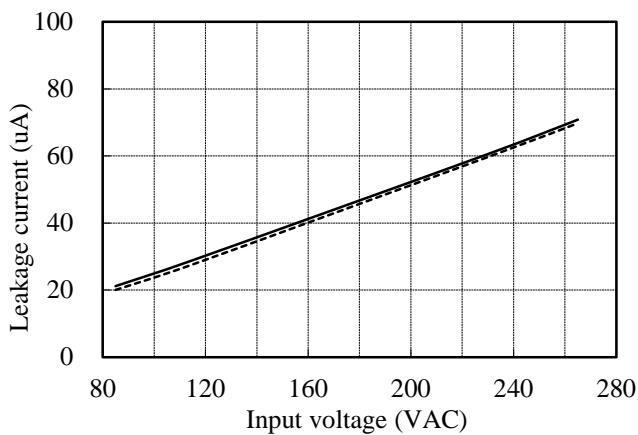

Single fault condition(Open FG)

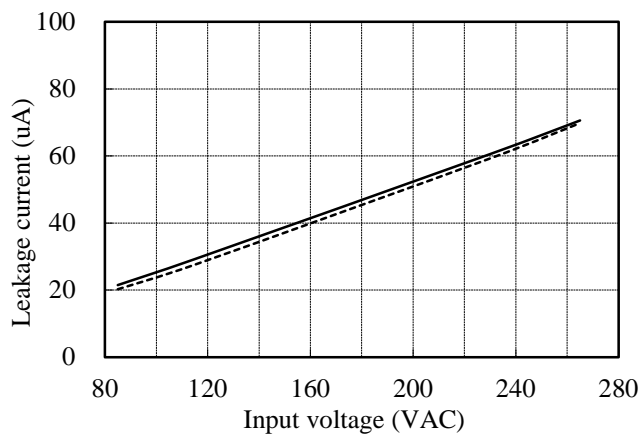

2.10 リーク電流特性  
Leakage current characteristics

CUS30M

Conditions Iout : 0 % -----  
                  100 % ——  
                  Ta : 25 °C  
Equipment used : SIQ16042

**12V**  
(CUS30M-12)

Patient leakage current of CLASS II equipment

f : 50 Hz

Normal condition

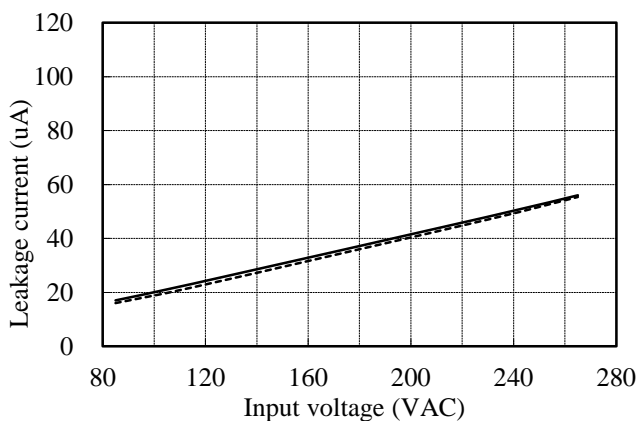

Single fault condition(Open L or N)

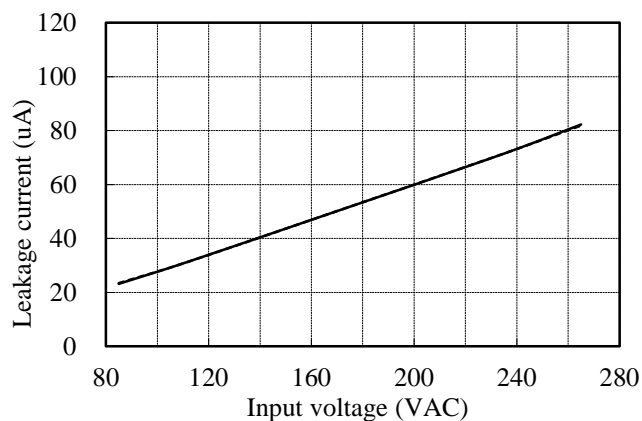

f : 60 Hz

Normal condition

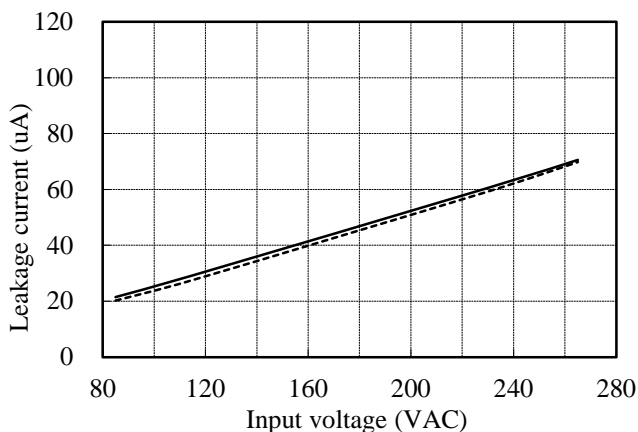

Single fault condition(Open L or N)

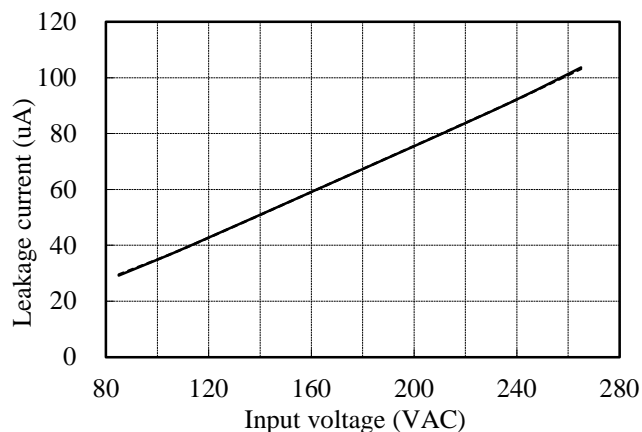

2.10 リーク電流特性  
Leakage current characteristics

CUS30M

Conditions Iout : 0 % -----  
100 % ———  
Ta : 25 °C  
Equipment used : SIMPSON228

**12V**  
(CUS30M-12)

Earth leakage current of CLASS I equipment

f : 50 Hz

Normal condition

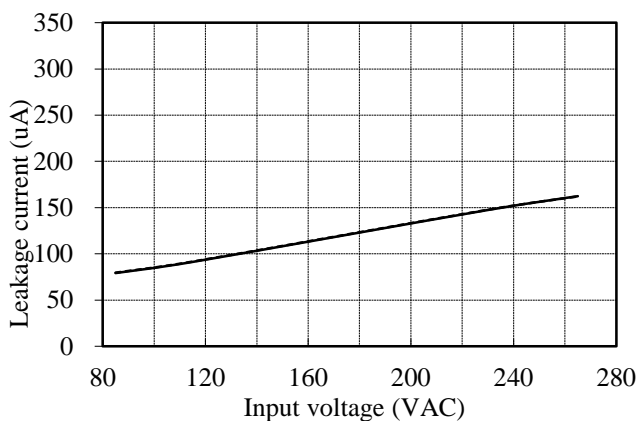

Single fault condition(Open L or N)

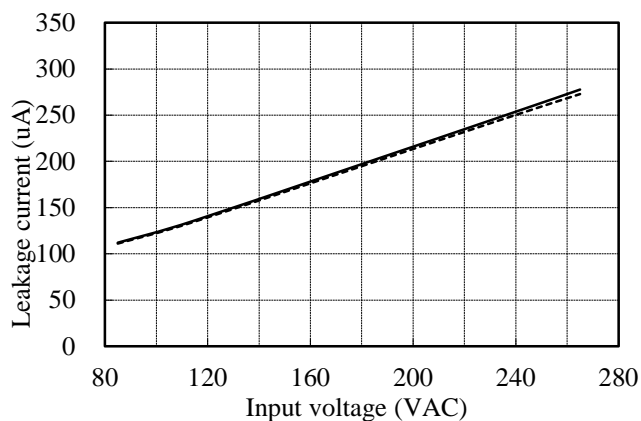

f : 60 Hz

Normal condition

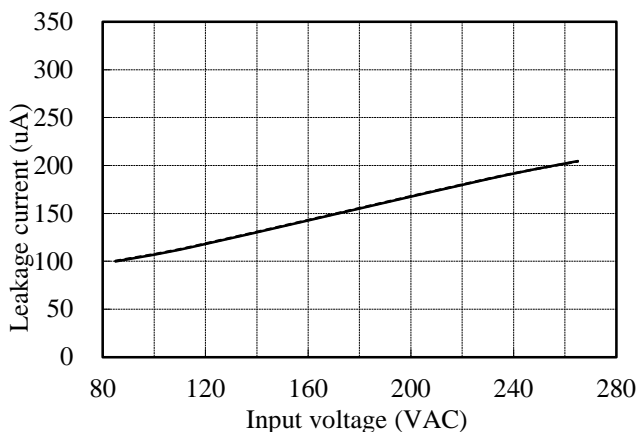

Single fault condition(Open L or N)

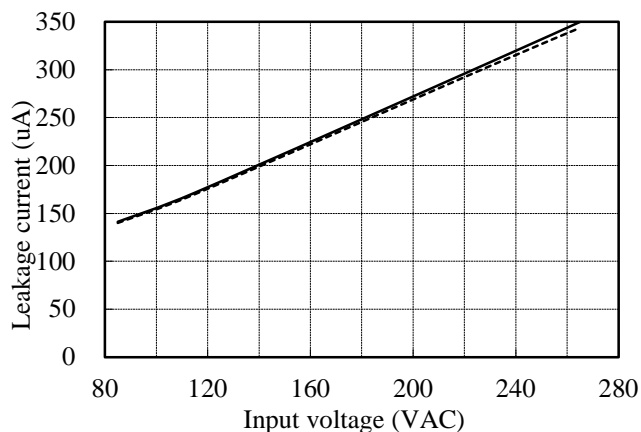

2.10 リーク電流特性  
Leakage current characteristics

CUS30M

Conditions Iout : 0 % -----  
100 % ————  
Ta : 25 °C  
Equipment used : SIQ16042

24V

  
(CUS30M-24)

Patient leakage current of CLASS I equipment

f : 50 Hz

Normal condition

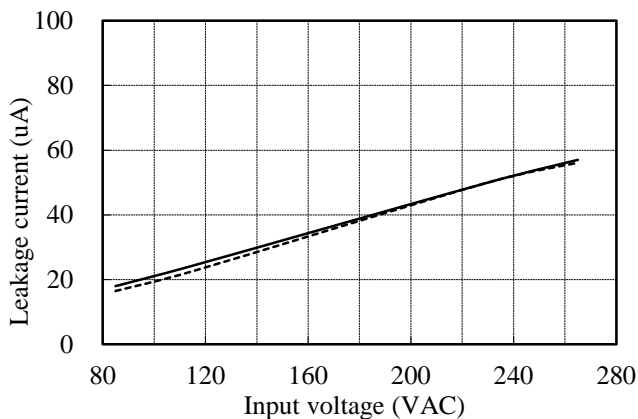

Single fault condition(Open FG)

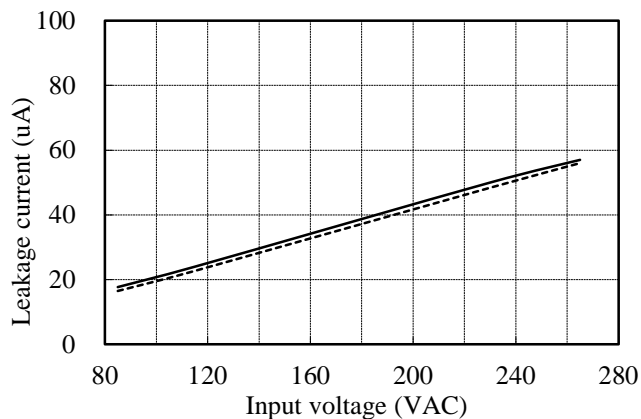

f : 60 Hz

Normal condition

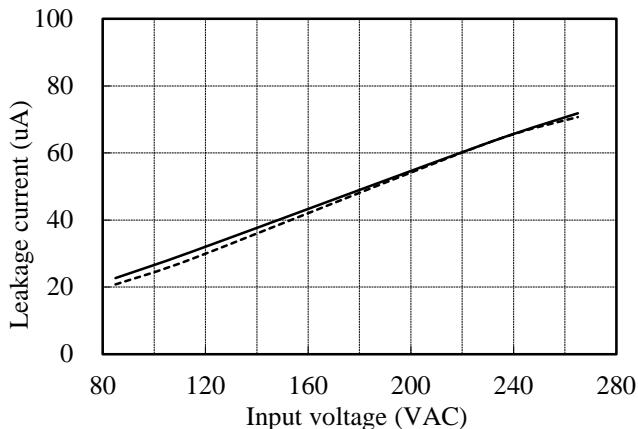

Single fault condition(Open FG)

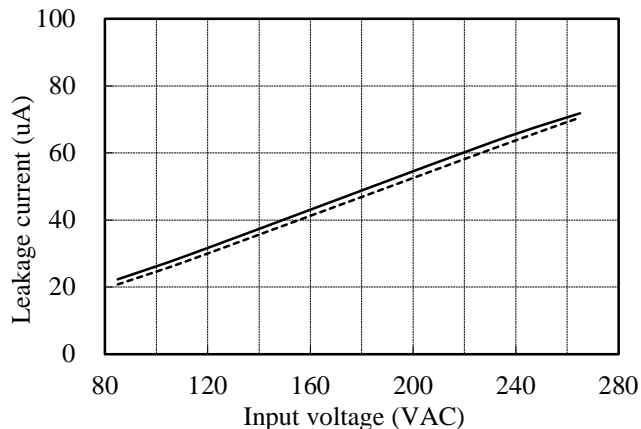



2.10 リーク電流特性  
Leakage current characteristics

CUS30M

Conditions Iout : 0 % -----  
100 % ——  
Ta : 25 °C  
Equipment used : SIQ16042

**24V**  
(CUS30M-24)

Patient leakage current of CLASS II equipment

f : 50 Hz

Normal condition

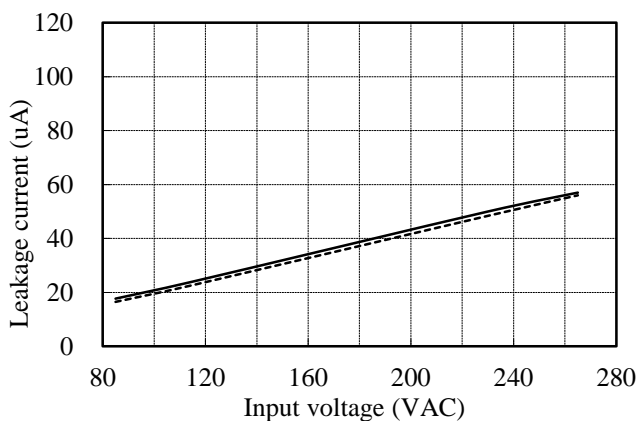

Single fault condition(Open L or N)

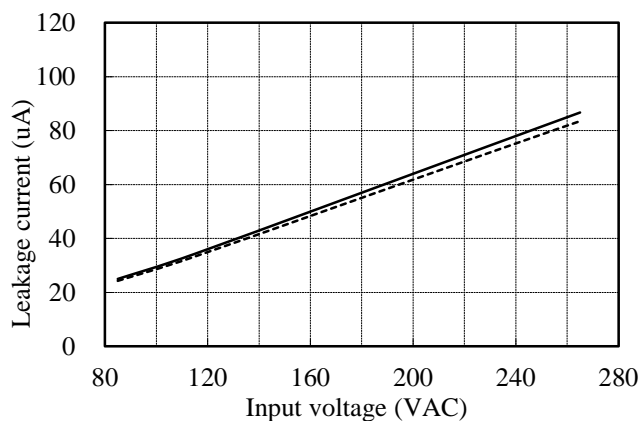

f : 60 Hz

Normal condition

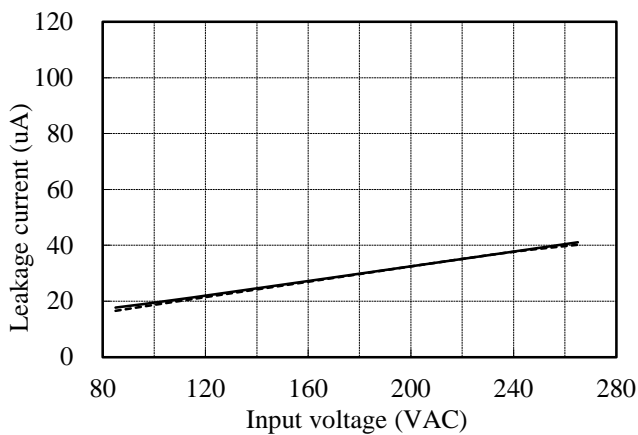

Single fault condition(Open L or N)

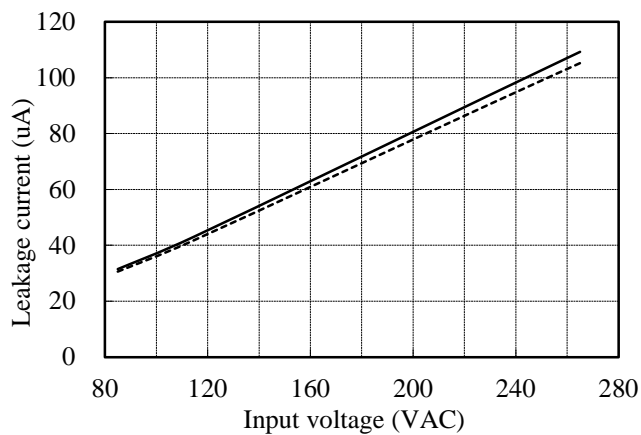

2.10 リーク電流特性  
Leakage current characteristics

CUS30M

Conditions Iout : 0 % -----  
100 % ——  
Ta : 25 °C  
Equipment used : SIMPSON228

**24V**  
(CUS30M-24)

Earth leakage current of CLASS I equipment

f : 50 Hz

Normal condition

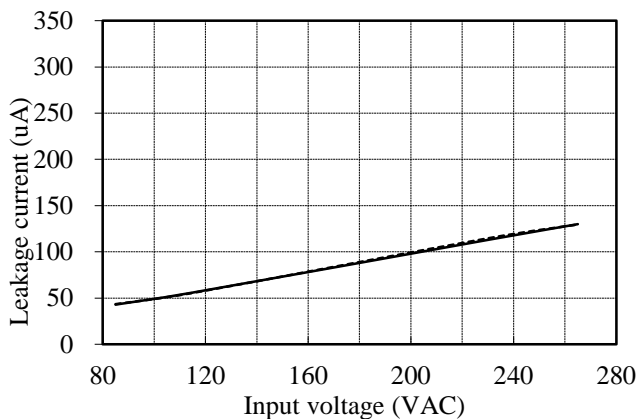

Single fault condition(Open L or N)

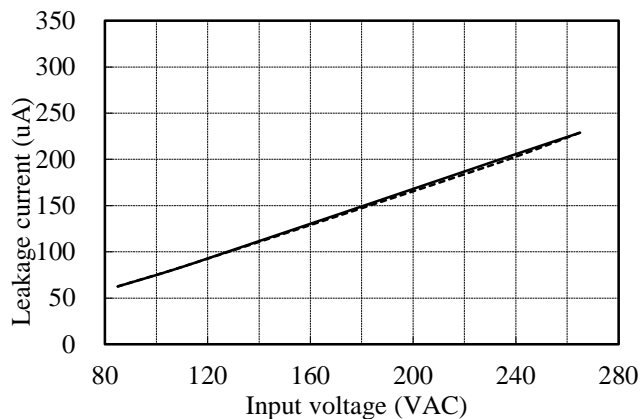

f : 60 Hz

Normal condition

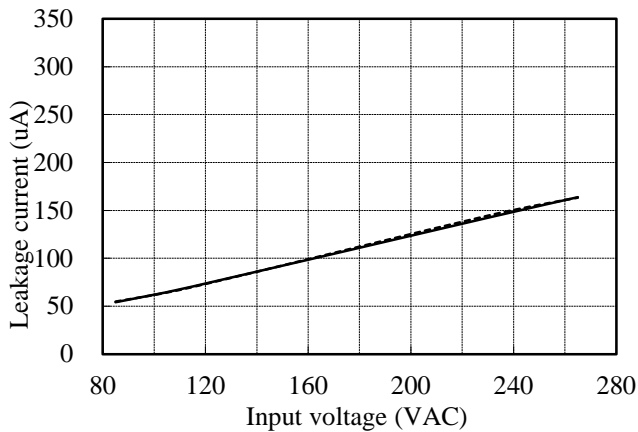

Single fault condition(Open L or N)

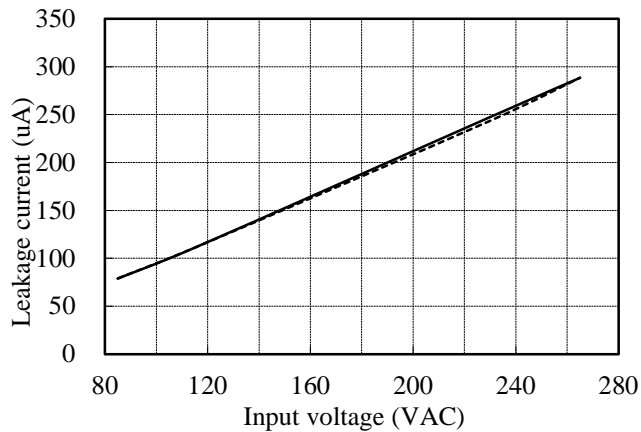

2.10 リーク電流特性  
Leakage current characteristics

CUS30M

Conditions Iout : 0 % -----  
100 % ——  
Ta : 25 °C  
Equipment used : SIQ16042

**48V**  
(CUS30M-48)

Patient leakage current of CLASS I equipment

f : 50 Hz

Normal condition

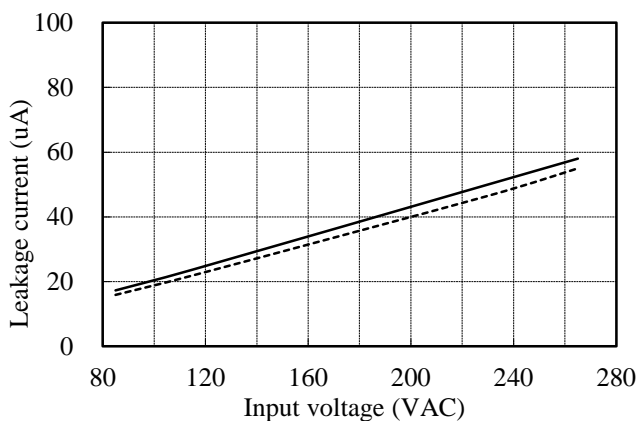

Single fault condition(Open FG)

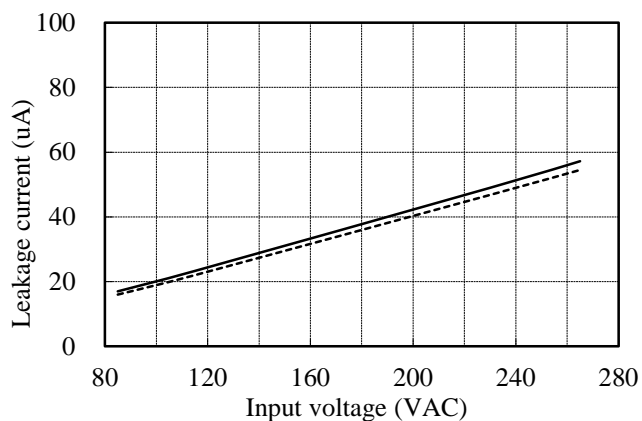

f : 60 Hz

Normal condition

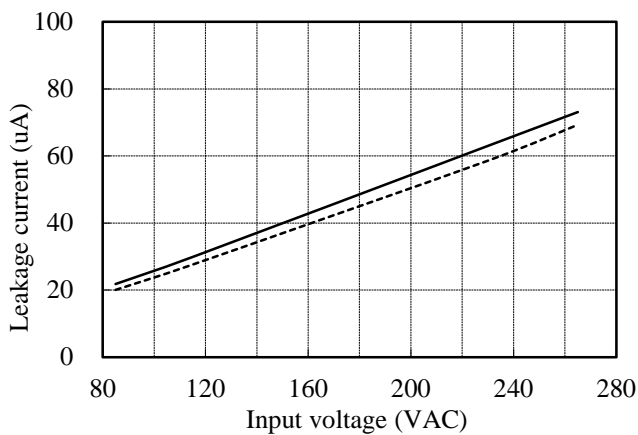

Single fault condition(Open FG)

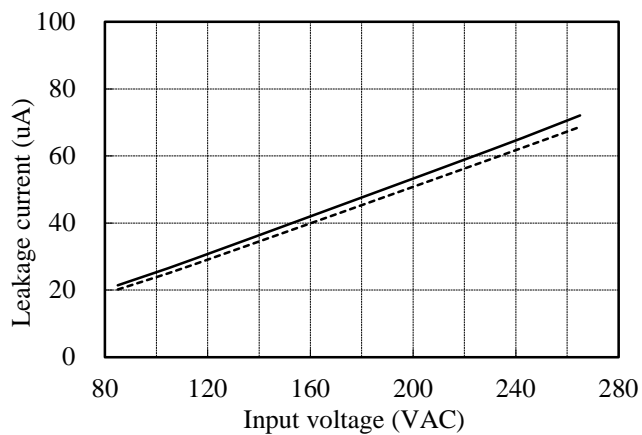

2.10 リーク電流特性  
Leakage current characteristics

CUS30M

Conditions Iout : 0 % -----  
100 % ——  
Ta : 25 °C  
Equipment used : SIQ16042

48V

  
(CUS30M-48)

Patient leakage current of CLASS II equipment

f : 50 Hz

Normal condition

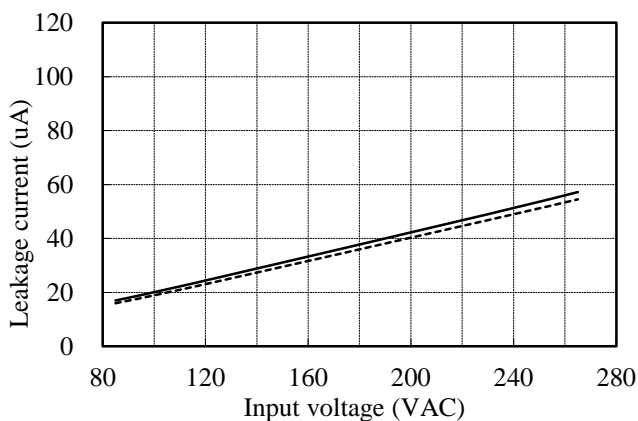

Single fault condition(Open L or N)

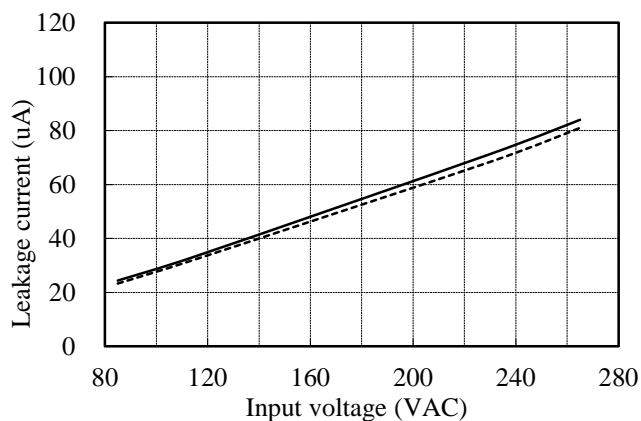

f : 60 Hz

Normal condition

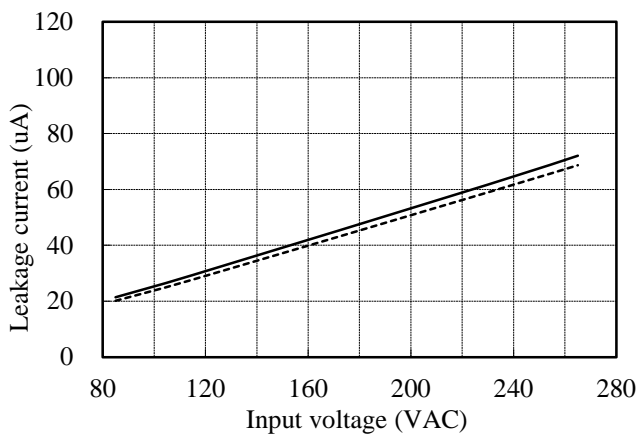

Single fault condition(Open L or N)

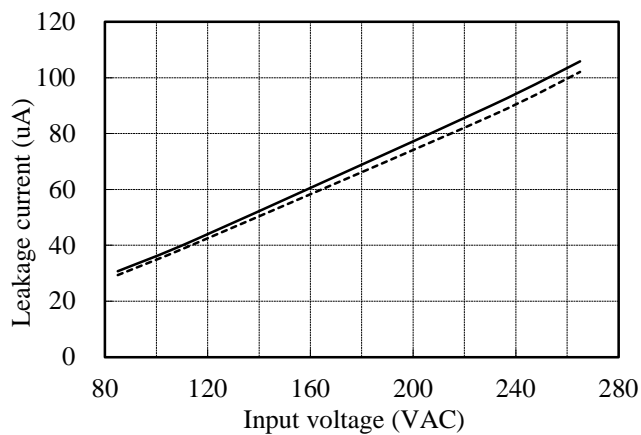

2.10 リーク電流特性  
Leakage current characteristics

CUS30M

Conditions Iout : 0 % -----  
                  100 % ————  
                  Ta : 25 °C  
Equipment used : SIMPSON228

**48V**  
(CUS30M-48)

Earth leakage current of CLASS I equipment

f : 50 Hz

Normal condition

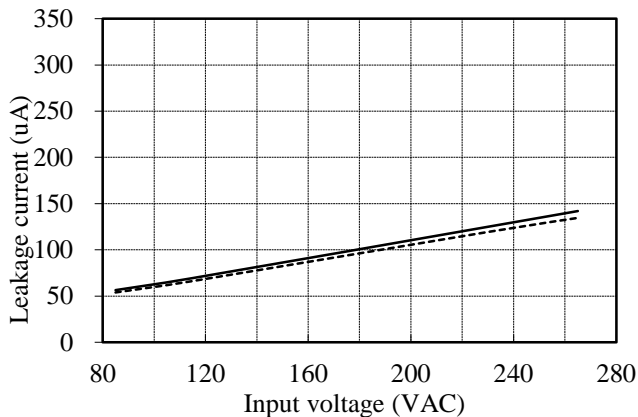

Single fault condition(Open L or N)

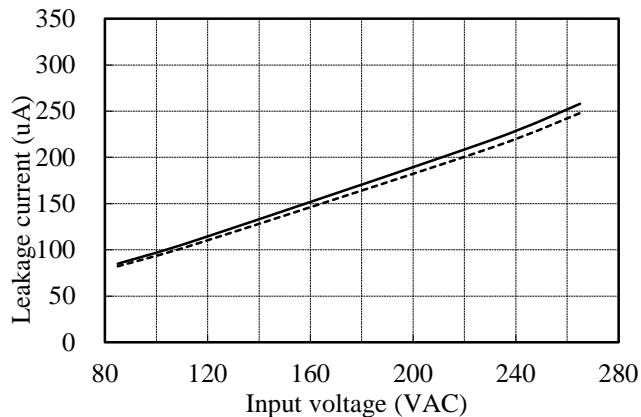

f : 60 Hz

Normal condition

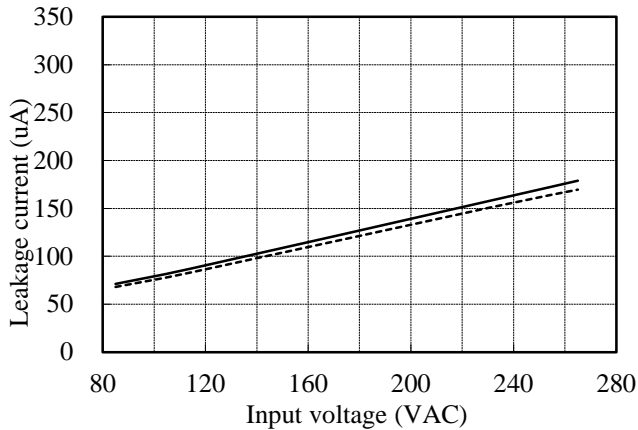

Single fault condition(Open L or N)

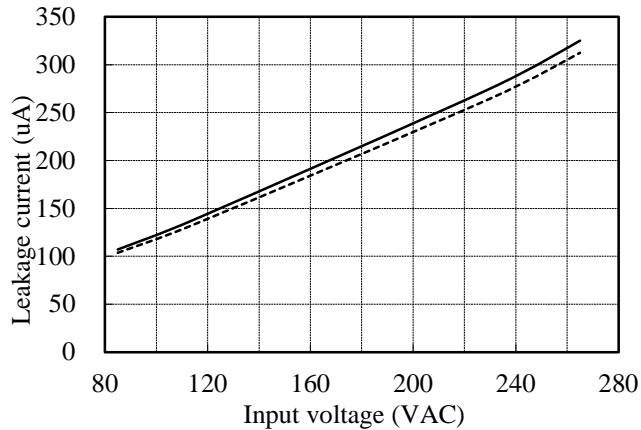

2.11 出力リップル、ノイズ波形  
Output ripple and noise waveform

CUS30M

Conditions

Vin : 115 VAC  
Ta : 25 °C

12V

(CUS30M-12)

Iout : 100%

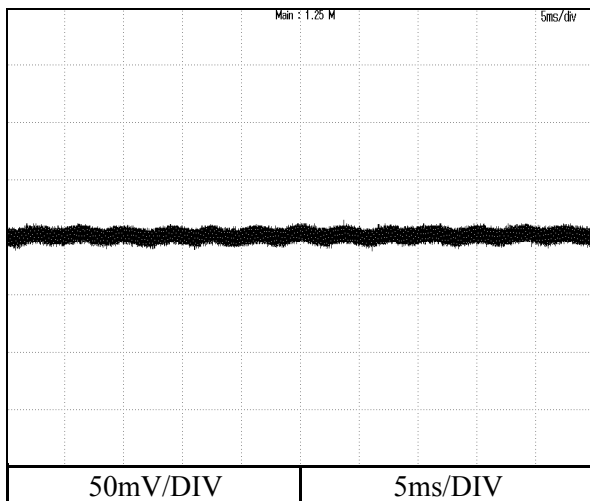

Iout : 100%

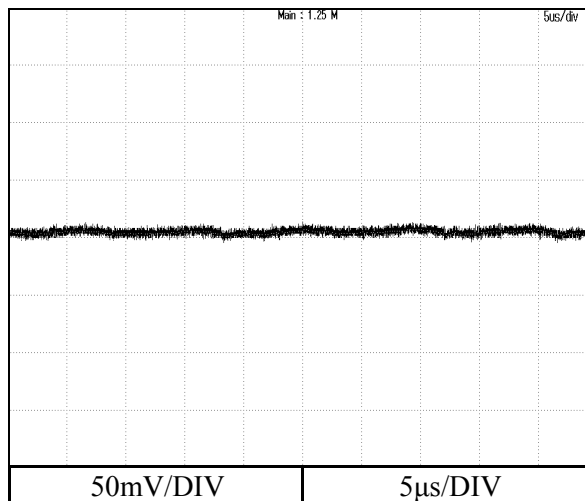

24V

(CUS30M-24)

Iout : 100%

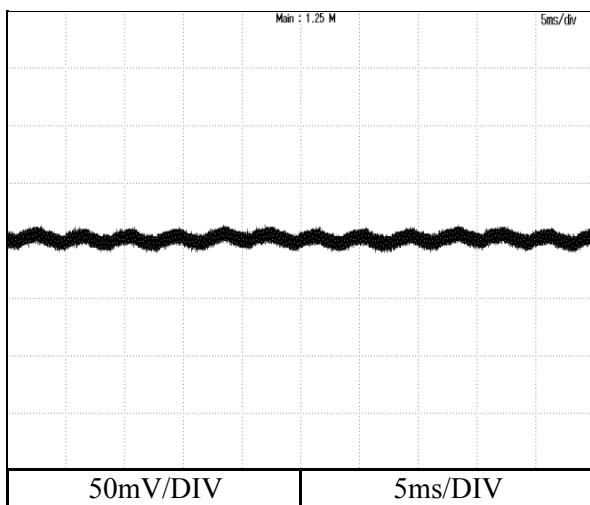

Iout : 100%

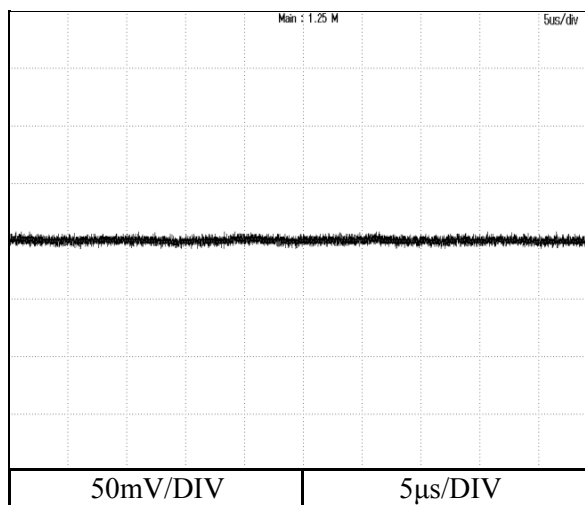

2.11 出力リップル、ノイズ波形  
Output ripple and noise waveform

CUS30M

Conditions

Vin : 115 VAC

Ta : 25 °C

48V

(CUS30M-48)

Iout : 100%

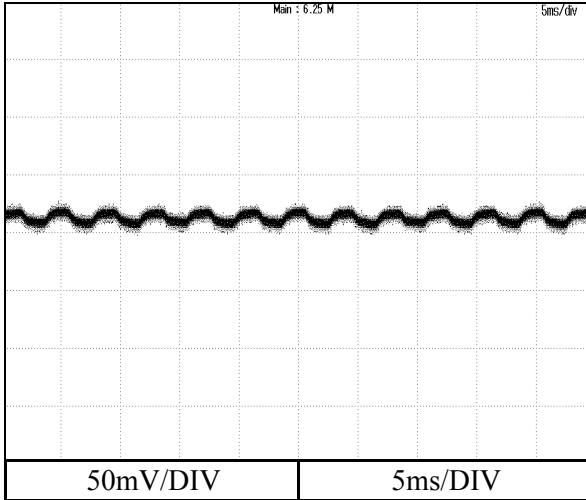

Iout : 100%

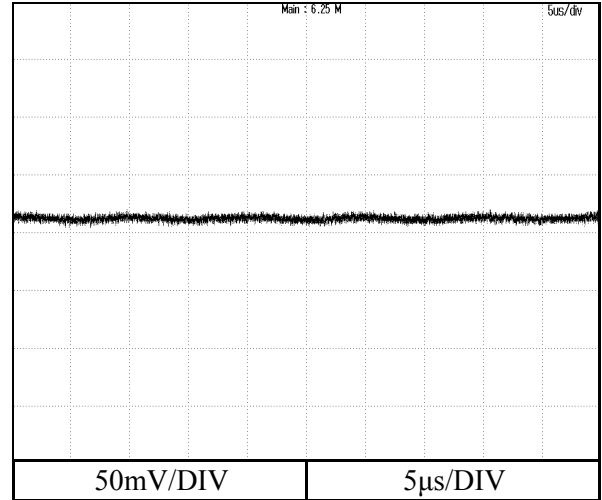

2.11 出力リップル、ノイズ波形  
Output ripple and noise waveform

CUS30M

Conditions

Vin : 230 VAC

Ta : 25 °C

12V

(CUS30M-12)

Iout : 100%

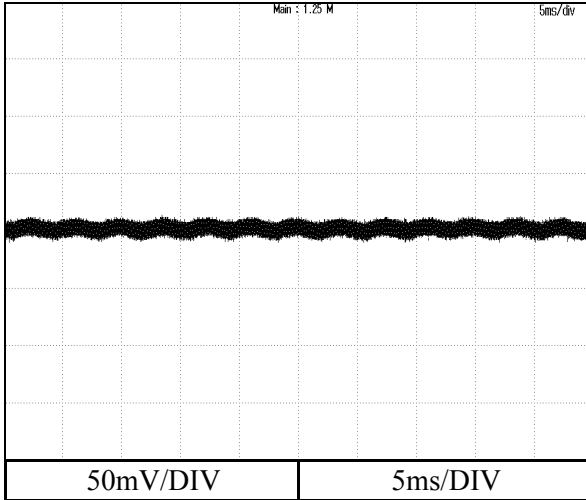

Iout : 100%

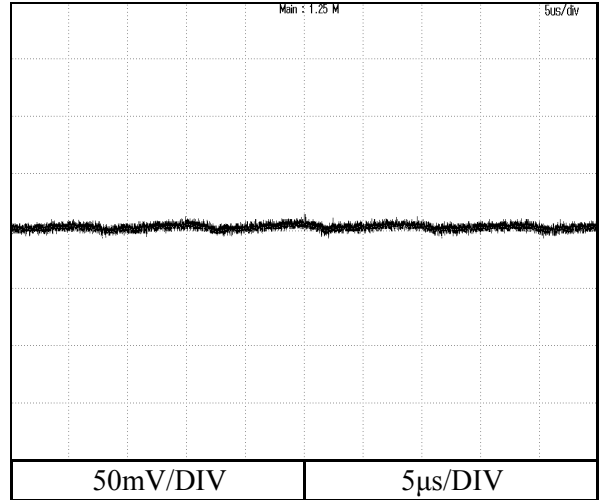

24V

(CUS30M-24)

Iout : 100%

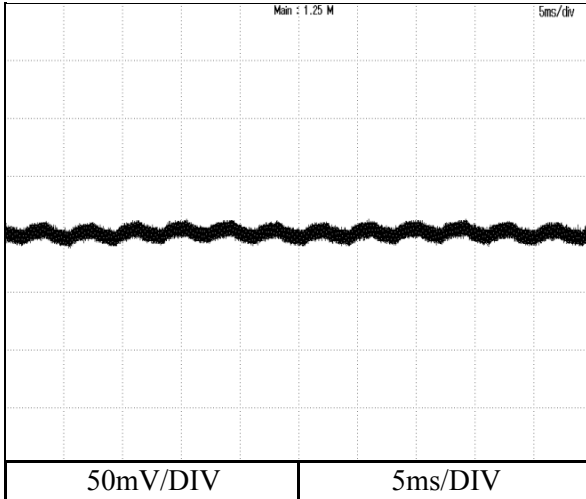

Iout : 100%

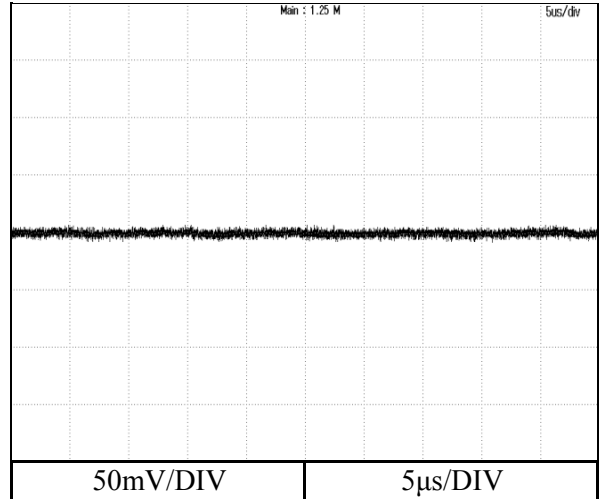



2.11 出力リップル、ノイズ波形  
Output ripple and noise waveform

CUS30M

Conditions

Vin : 230 VAC

Ta : 25 °C

48V

(CUS30M-48)

Iout : 100%

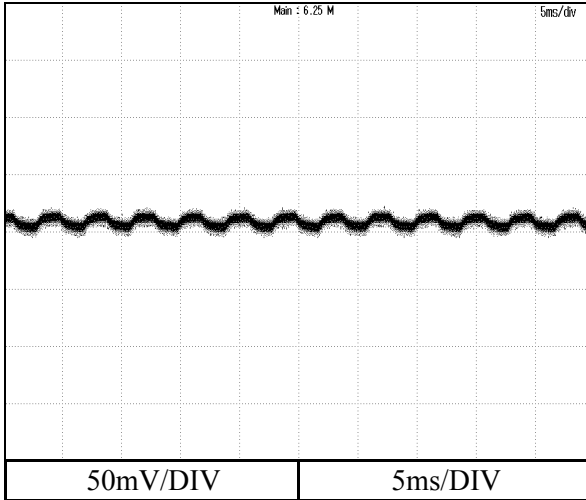

Iout : 100%

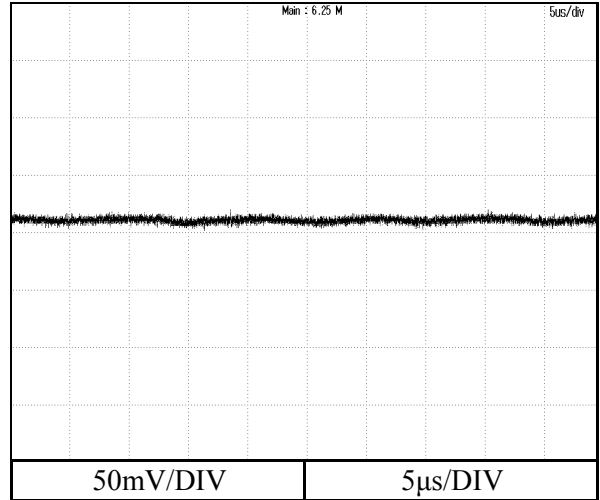

2.12 EMI 特性

Electro-Magnetic Interference characteristics

CUS30M

Conditions Vin : 115 VAC  
Iout : 100 %  
Ta : 25 °C

雑音端子電圧

Conducted Emission (CLASS I)

12V

(CUS30M-12)

Point A (0.195MHz)		
Ref. Data	Limit (dBuV)	Measure (dBuV)
QP	63.8	53.8
AV	53.6	38.2

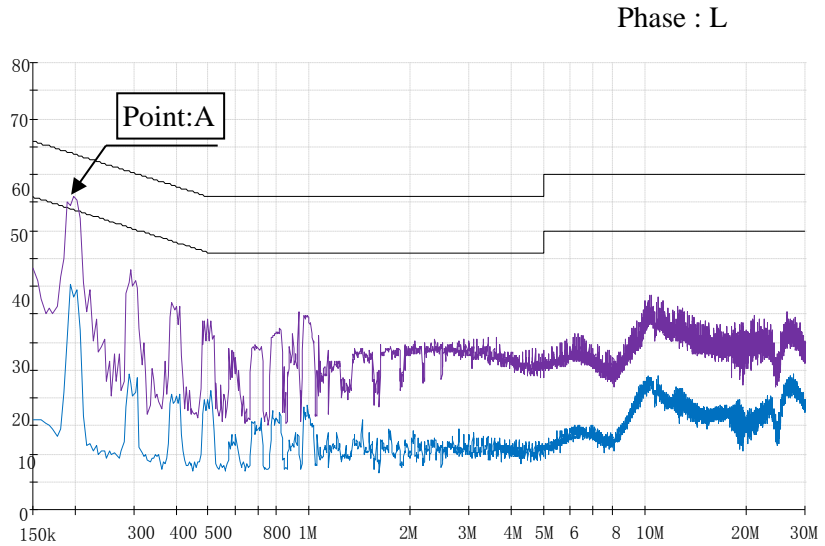

EN55032  
Class B  
QP Limit



EN55032  
Class B  
AV Limit

Point B (0.190MHz)		
Ref. Data	Limit (dBuV)	Measure (dBuV)
QP	64.0	51.3
AV	53.8	35.5

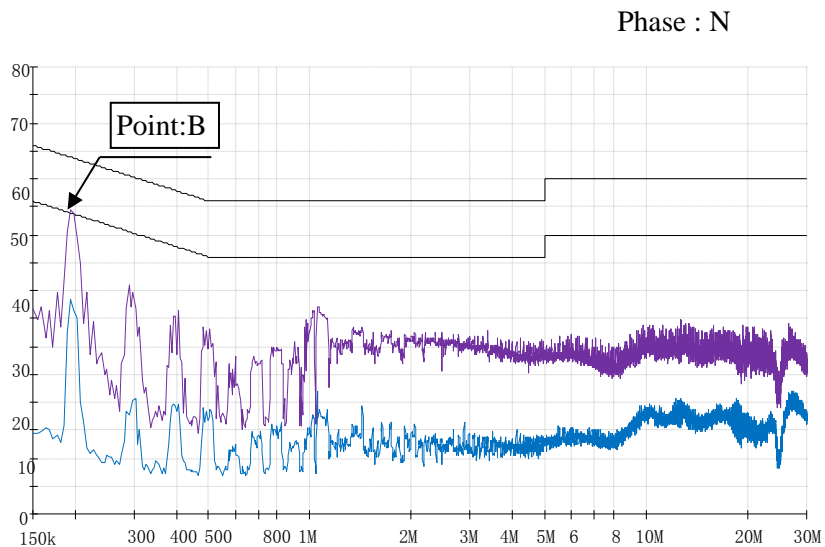

EN55032  
Class B  
QP Limit



EN55032  
Class B  
AV Limit

EN55011-B,VCCI-B,FCC-Bの限界値はEN55032 class Bの限界値と同じ

Limit of EN55011-B,VCCI-B,FCC-B are same as its EN55032 class B.

## 2.12 EMI 特性

Electro-Magnetic Interference characteristics

# CUS30M

Conditions Vin : 230 VAC  
Iout : 100 %  
Ta : 25 °C

雑音端子電圧

Conducted Emission (CLASS I)

12V  
(CUS30M-12)

Point A (0.195MHz)		
Ref. Data	Limit (dBuV)	Measure (dBuV)
QP	63.8	51.8
AV	53.4	33.7

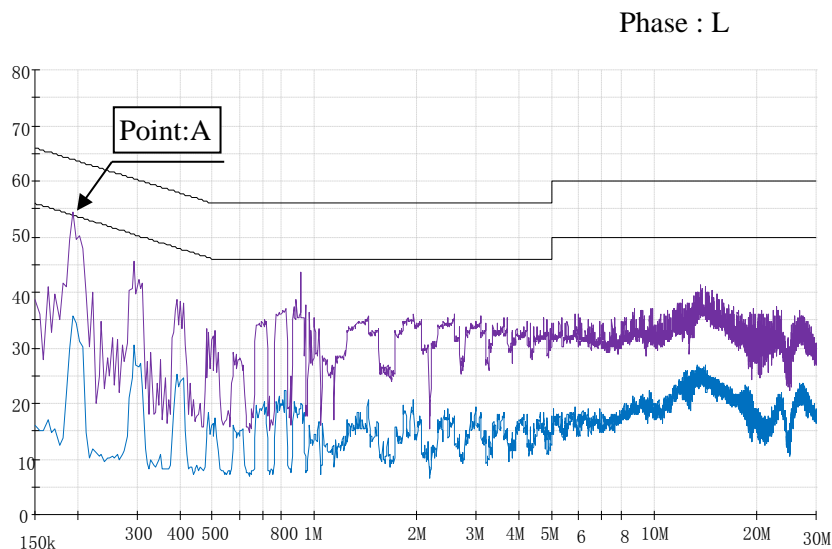

EN55032  
Class B  
QP Limit  
←  
←  
EN55032  
Class B  
AV Limit

Point B (0.20MHz)		
Ref. Data	Limit (dBuV)	Measure (dBuV)
QP	63.6	51.5
AV	53.4	32.1

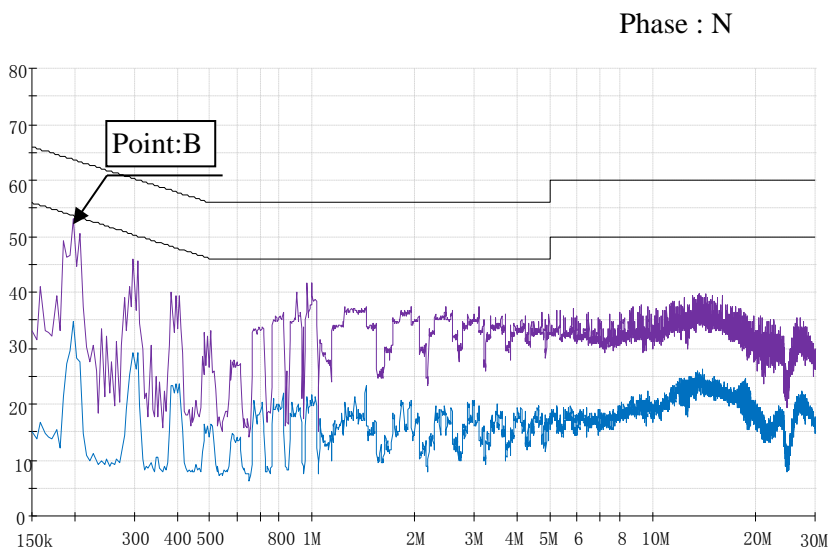

EN55032  
Class B  
QP Limit  
←  
←  
EN55032  
Class B  
AV Limit

EN55011-B,VCCI-B,FCC-Bの限界値はEN55032 class Bの限界値と同じ  
Limit of EN55011-B,VCCI-B,FCC-B are same as its EN55032 class B.

2.12 EMI 特性

Electro-Magnetic Interference characteristics

CUS30M

Conditions Vin : 115 VAC  
Iout : 100 %  
Ta : 25 °C

雑音端子電圧

Conducted Emission (CLASS II)

12V

(CUS30M-12)

Point A (0.195MHz)		
Ref. Data	Limit (dBuV)	Measure (dBuV)
QP	63.8	54.9
AV	53.8	42.1

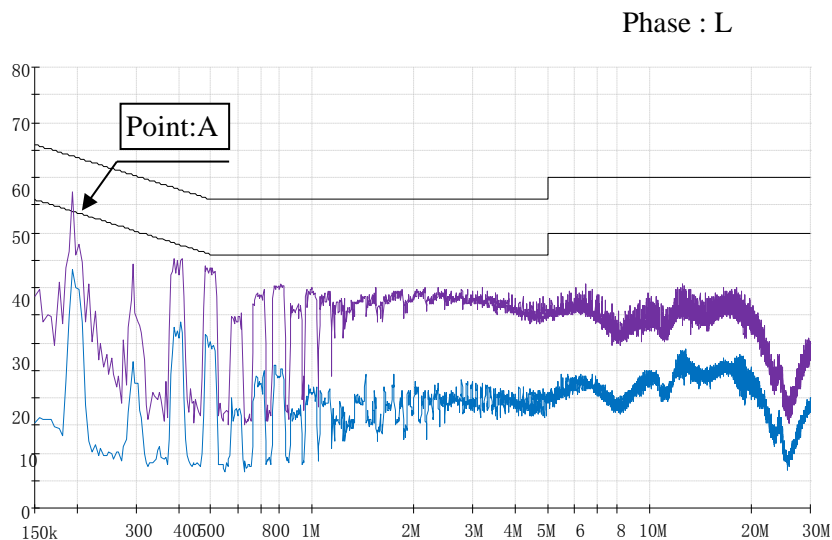

EN55032  
Class B  
QP Limit  
←  
←  
EN55032  
Class B  
AV Limit

Point B (0.204MHz)		
Ref. Data	Limit (dBuV)	Measure (dBuV)
QP	63.4	51.7
AV	53.8	41.1

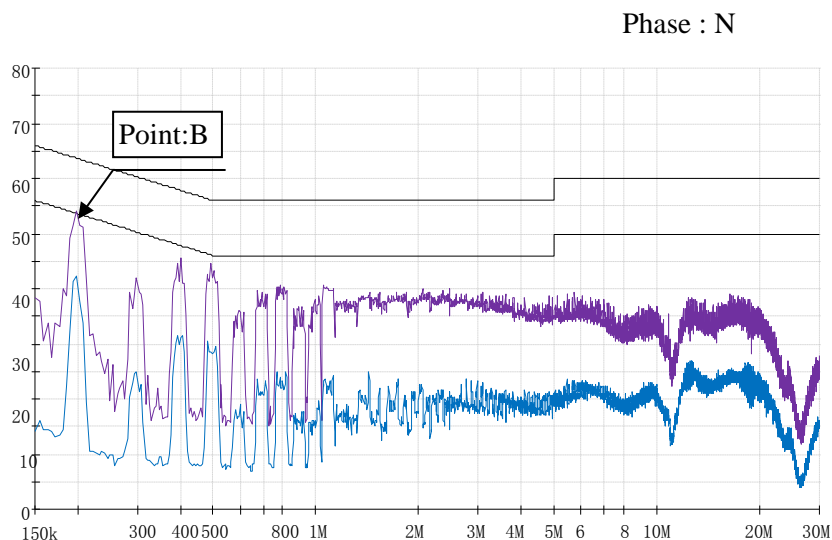

EN55032  
Class B  
QP Limit  
←  
←  
EN55032  
Class B  
AV Limit

EN55011-B,VCCI-B,FCC-Bの限界値はEN55032 class Bの限界値と同じ  
Limit of EN55011-B,VCCI-B,FCC-B are same as its EN55032 class B.

2.12 EMI 特性

Electro-Magnetic Interference characteristics

CUS30M

Conditions Vin : 230 VAC  
Iout : 100 %  
Ta : 25 °C

雑音端子電圧

Conducted Emission (CLASS II)

12V

(CUS30M-12)

Point A (0.195MHz)		
Ref. Data	Limit (dBuV)	Measure (dBuV)
QP	63.8	53.8
AV	53.4	42.6

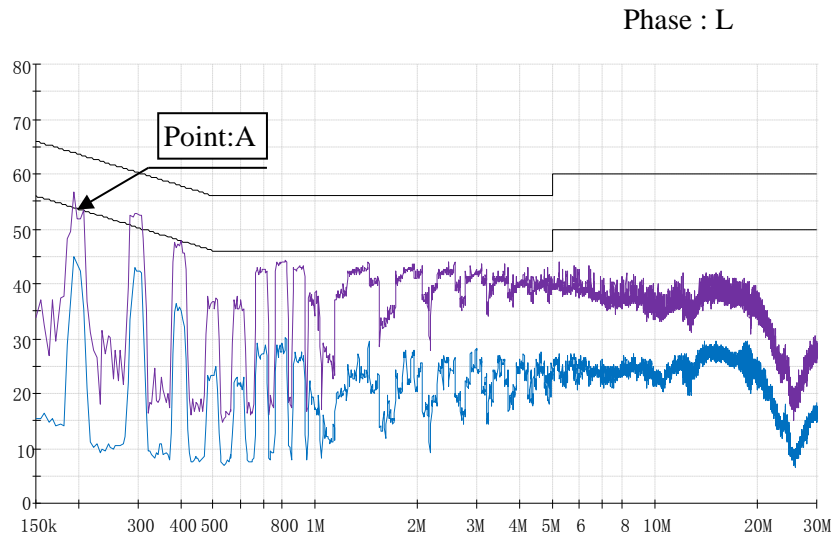

EN55032  
Class B  
QP Limit



EN55032  
Class B  
AV Limit

Point B (0.204MHz)		
Ref. Data	Limit (dBuV)	Measure (dBuV)
QP	63.4	54.2
AV	53.8	44.8

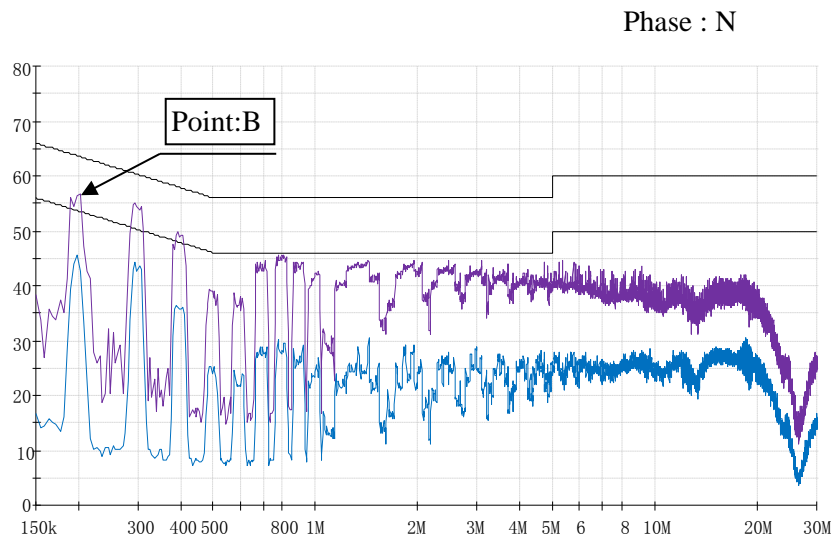

EN55032  
Class B  
QP Limit



EN55032  
Class B  
AV Limit

EN55011-B,VCCI-B,FCC-Bの限界値はEN55032 class Bの限界値と同じ

Limit of EN55011-B,VCCI-B,FCC-B are same as its EN55032 class B.

2.12 EMI 特性

Electro-Magnetic Interference characteristics

CUS30M

Conditions Vin : 115 VAC  
Iout : 100 %  
Ta : 25 °C

雑音端子電圧

Conducted Emission (CLASS I)

24V

(CUS30M-24)

Point A (0.21MHz)		
Ref. Data	Limit (dBuV)	Measure (dBuV)
QP	63.8	54.1
AV	53.8	34.7

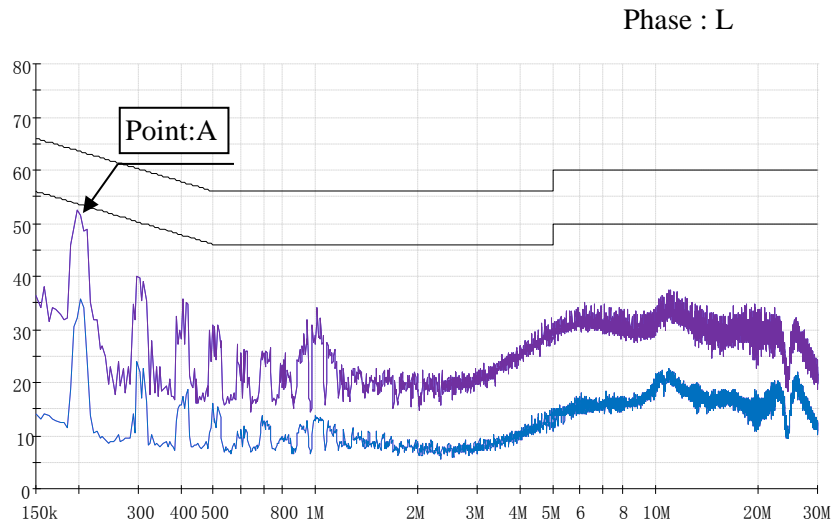

EN55032  
Class B  
QP Limit



EN55032  
Class B  
AV Limit

Point B (0.20MHz)		
Ref. Data	Limit (dBuV)	Measure (dBuV)
QP	63.8	53.2
AV	53.8	36.8

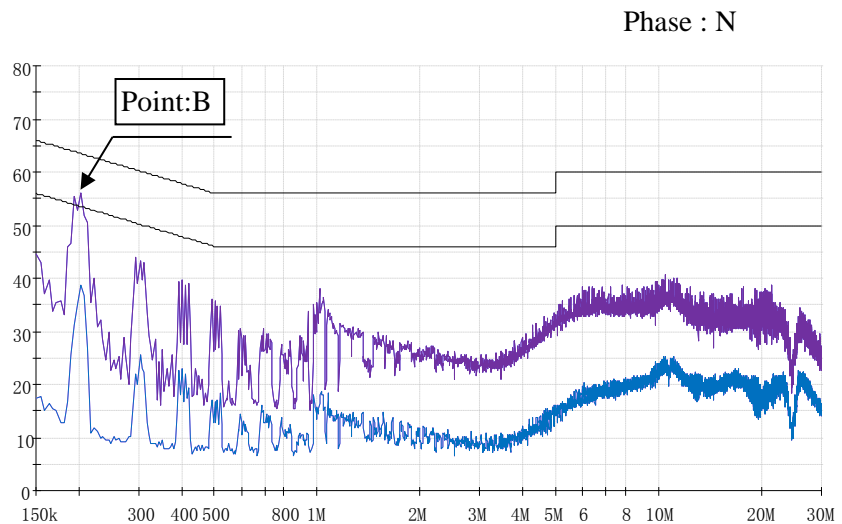

EN55032  
Class B  
QP Limit



EN55032  
Class B  
AV Limit

EN55011-B,VCCI-B,FCC-Bの限界値はEN55032 class Bの限界値と同じ

Limit of EN55011-B,VCCI-B,FCC-B are same as its EN55032 class B.

2.12 EMI 特性

Electro-Magnetic Interference characteristics

CUS30M

Conditions Vin : 230 VAC  
Iout : 100 %  
Ta : 25 °C

雑音端子電圧

Conducted Emission (CLASS I)

24V

(CUS30M-24)

Point A (0.19MHz)		
Ref. Data	Limit (dBuV)	Measure (dBuV)
QP	63.8	53.1
AV	53.8	31.0

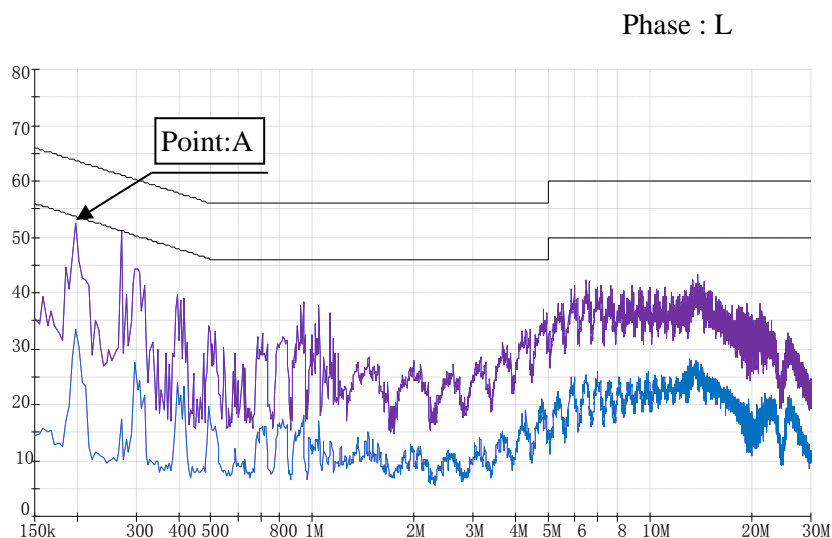

EN55032  
Class B  
QP Limit  
←  
←  
EN55032  
Class B  
AV Limit

Point B (0.19MHz)		
Ref. Data	Limit (dBuV)	Measure (dBuV)
QP	63.8	53.0
AV	53.8	32.2

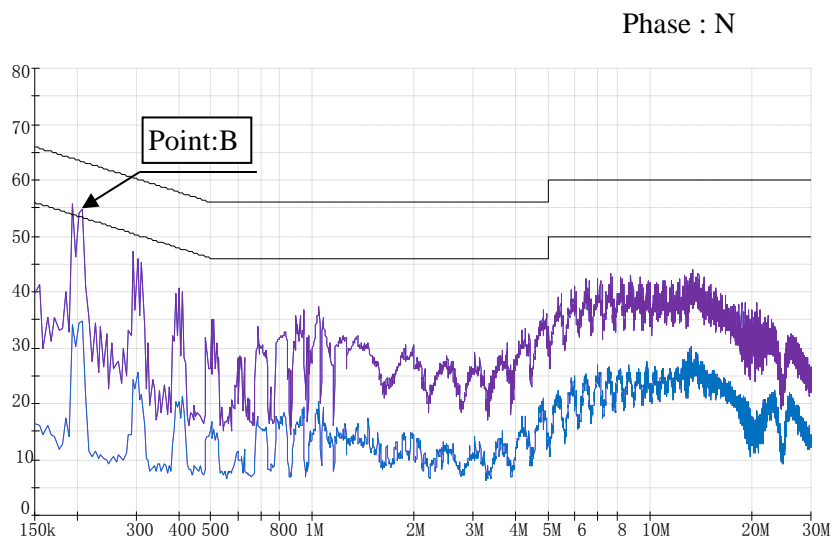

EN55032  
Class B  
QP Limit  
←  
←  
EN55032  
Class B  
AV Limit

EN55011-B,VCCI-B,FCC-Bの限界値はEN55032 class Bの限界値と同じ  
Limit of EN55011-B,VCCI-B,FCC-B are same as its EN55032 class B.

2.12 EMI 特性

Electro-Magnetic Interference characteristics

CUS30M

Conditions Vin : 115 VAC  
Iout : 100 %  
Ta : 25 °C

雑音端子電圧

Conducted Emission (CLASS II)

24V

(CUS30M-24)

Point A (1.88MHz)		
Ref. Data	Limit (dBuV)	Measure (dBuV)
QP	63.8	55.0
AV	53.8	44.1

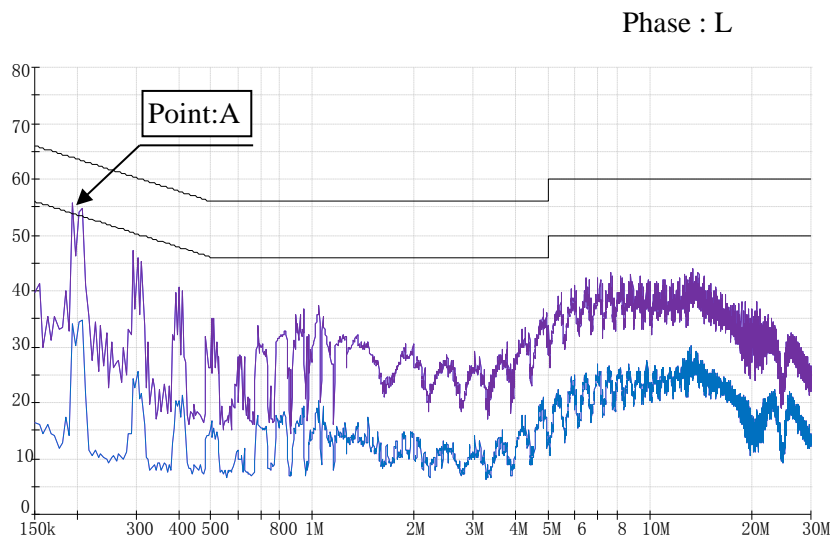

EN55032  
Class B  
QP Limit



EN55032  
Class B  
AV Limit

Point B (3.18MHz)		
Ref. Data	Limit (dBuV)	Measure (dBuV)
QP	63.8	55.9
AV	53.8	42.6

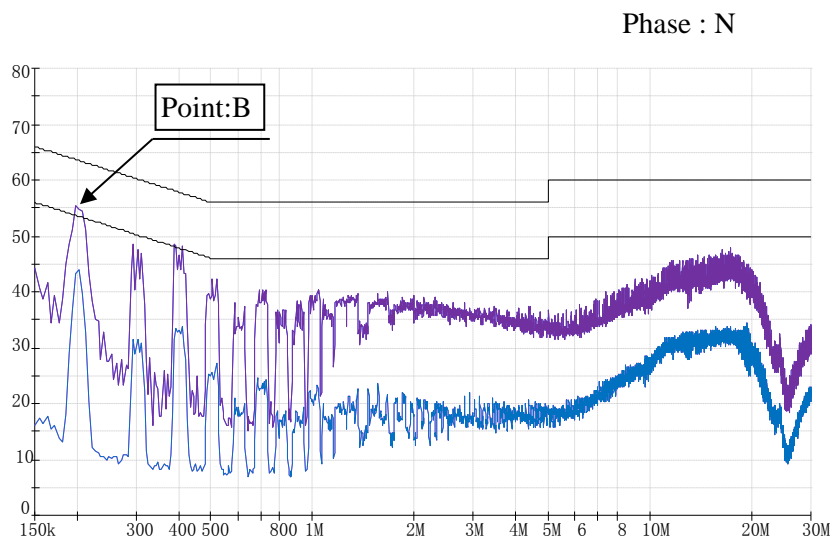

EN55032  
Class B  
QP Limit



EN55032  
Class B  
AV Limit

EN55011-B,VCCI-B,FCC-Bの限界値はEN55032 class Bの限界値と同じ

Limit of EN55011-B,VCCI-B,FCC-B are same as its EN55032 class B.



2.12 EMI 特性

Electro-Magnetic Interference characteristics

CUS30M

Conditions Vin : 230 VAC  
Iout : 100 %  
Ta : 25 °C

雑音端子電圧

Conducted Emission (CLASS II)

24V

(CUS30M-24)

Point A (0.20MHz)		
Ref. Data	Limit (dBuV)	Measure (dBuV)
QP	63.8	56.8
AV	53.8	44.0

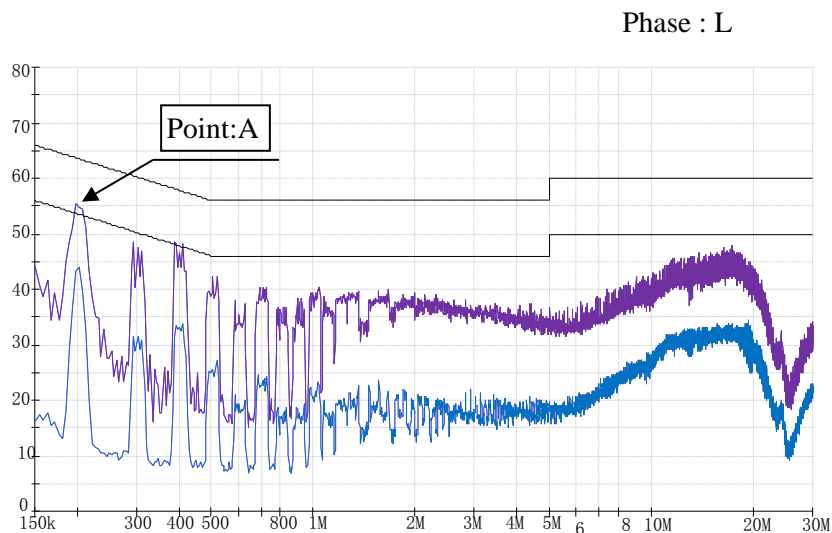

EN55032  
Class B  
QP Limit



EN55032  
Class B  
AV Limit

Point B (0.20MHz)		
Ref. Data	Limit (dBuV)	Measure (dBuV)
QP	63.8	57.4
AV	53.8	47.3

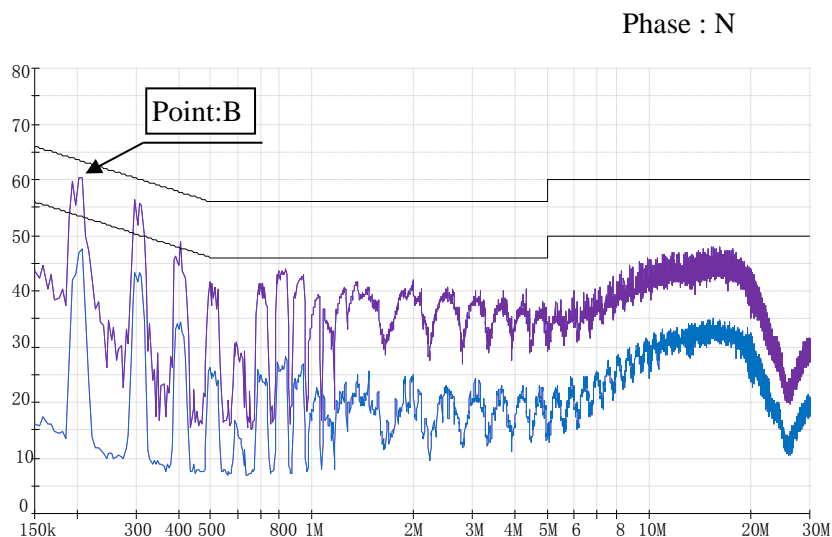

EN55032  
Class B  
QP Limit



EN55032  
Class B  
AV Limit

EN55011-B,VCCI-B,FCC-Bの限界値はEN55032 class Bの限界値と同じ  
Limit of EN55011-B,VCCI-B,FCC-B are same as its EN55032 class B.

2.12 EMI 特性

Electro-Magnetic Interference characteristics

CUS30M

Conditions Vin : 115 VAC  
Iout : 100 %  
Ta : 25 °C

雑音端子電圧

Conducted Emission (CLASS I)

48V

(CUS30M-48)

Point A (0.195MHz)		
Ref. Data	Limit (dBuV)	Measure (dBuV)
QP	63.8	52.0
AV	53.6	35.0

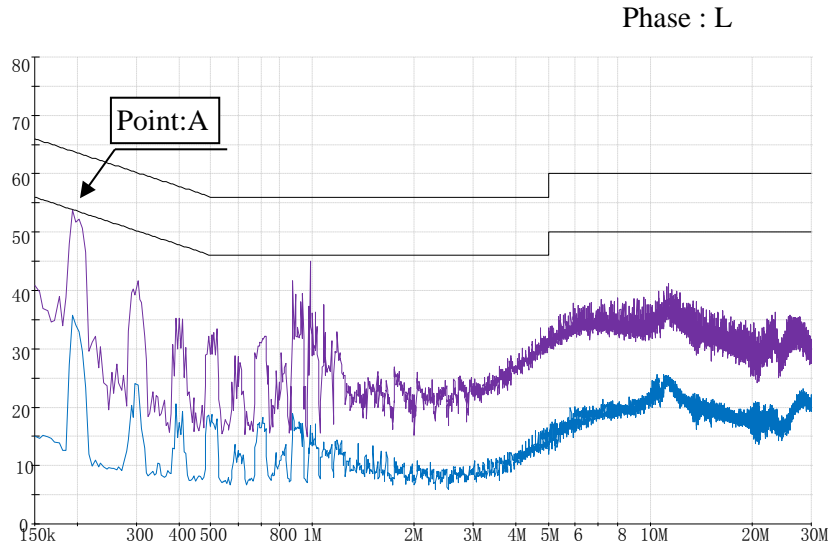

Point B (0.195MHz)		
Ref. Data	Limit (dBuV)	Measure (dBuV)
QP	63.8	48.6
AV	53.8	30.9

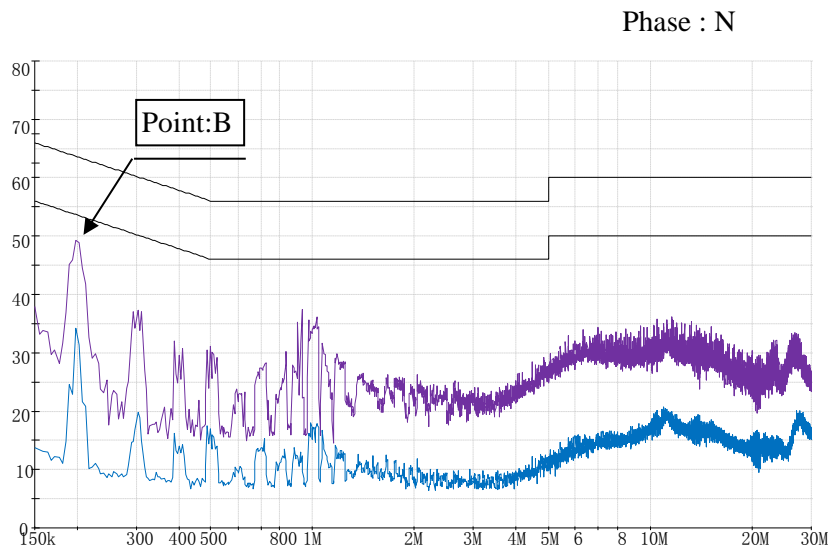

EN55011-B,VCCI-B,FCC-Bの限界値はEN55032 class Bの限界値と同じ  
Limit of EN55011-B,VCCI-B,FCC-B are same as its EN55032 class B.

2.12 EMI 特性

Electro-Magnetic Interference characteristics

CUS30M

Conditions Vin : 230 VAC  
Iout : 100 %  
Ta : 25 °C

雑音端子電圧

Conducted Emission (CLASS I)

48V

(CUS30M-48)

Point A (0.929MHz)		
Ref. Data	Limit (dBuV)	Measure (dBuV)
QP	56.0	39.6
AV	46.0	30.0

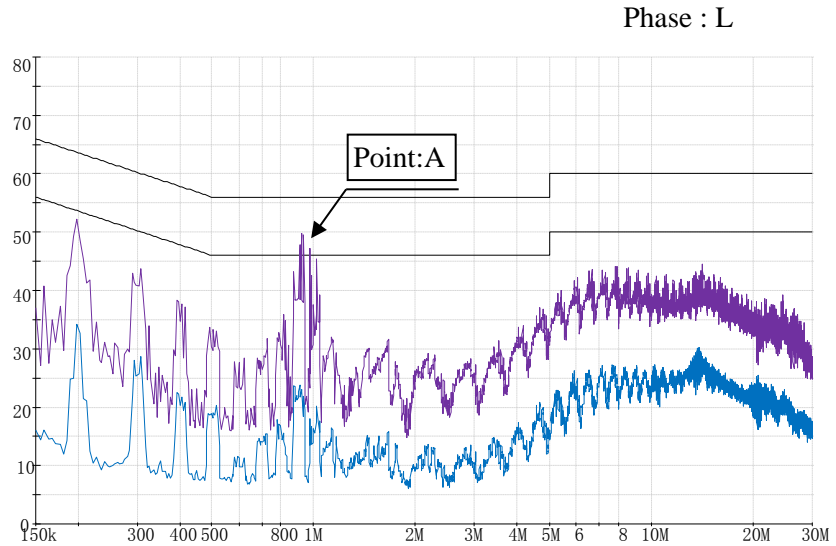

EN55032  
Class B  
QP Limit



EN55032  
Class B  
AV Limit

Point B (0.925MHz)		
Ref. Data	Limit (dBuV)	Measure (dBuV)
QP	56.0	39.3
AV	46.0	29.1

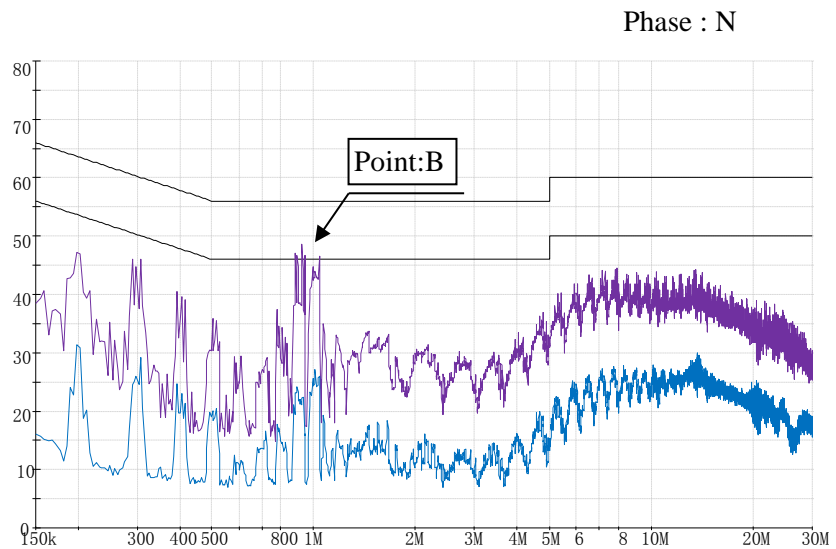

EN55032  
Class B  
QP Limit



EN55032  
Class B  
AV Limit

EN55011-B,VCCI-B,FCC-Bの限界値はEN55032 class Bの限界値と同じ

Limit of EN55011-B,VCCI-B,FCC-B are same as its EN55032 class B.

2.12 EMI 特性

Electro-Magnetic Interference characteristics

CUS30M

Conditions Vin : 115 VAC  
Iout : 100 %  
Ta : 25 °C

雑音端子電圧

Conducted Emission (CLASS II)

48V

(CUS30M-48)

Point A (0.195MHz)		
Ref. Data	Limit (dBuV)	Measure (dBuV)
QP	63.8	53.9
AV	53.8	39.8

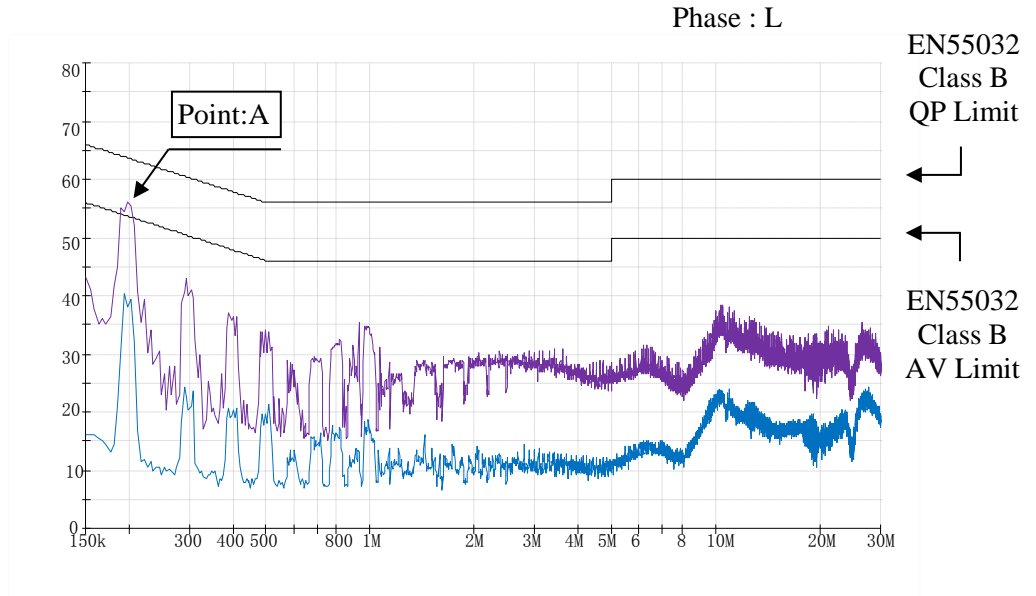

Point B (0.200MHz)		
Ref. Data	Limit (dBuV)	Measure (dBuV)
QP	63.6	49.2
AV	53.6	39.3

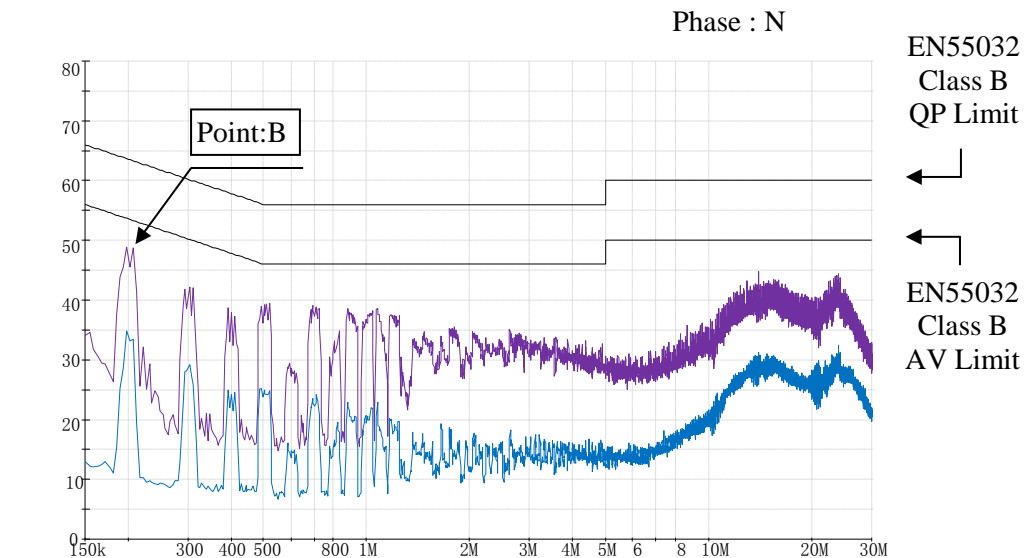

EN55011-B,VCCI-B,FCC-Bの限界値はEN55032 class Bの限界値と同じ  
Limit of EN55011-B,VCCI-B,FCC-B are same as its EN55032 class B.

2.12 EMI 特性

Electro-Magnetic Interference characteristics

CUS30M

Conditions Vin : 230 VAC  
Iout : 100 %  
Ta : 25 °C

雑音端子電圧

Conducted Emission (CLASS II)

48V

(CUS30M-48)

Point A (0.303MHz)		
Ref. Data	Limit (dBuV)	Measure (dBuV)
QP	60.2	53.9
AV	50.2	44.9

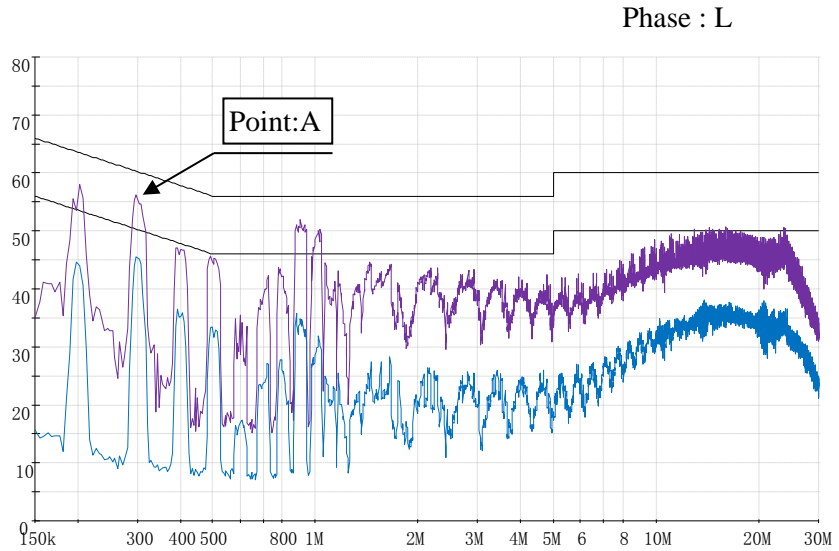

EN55032  
Class B  
QP Limit  
←  
←  
EN55032  
Class B  
AV Limit

Point B (0.299MHz)		
Ref. Data	Limit (dBuV)	Measure (dBuV)
QP	60.3	52.9
AV	50.3	43.8

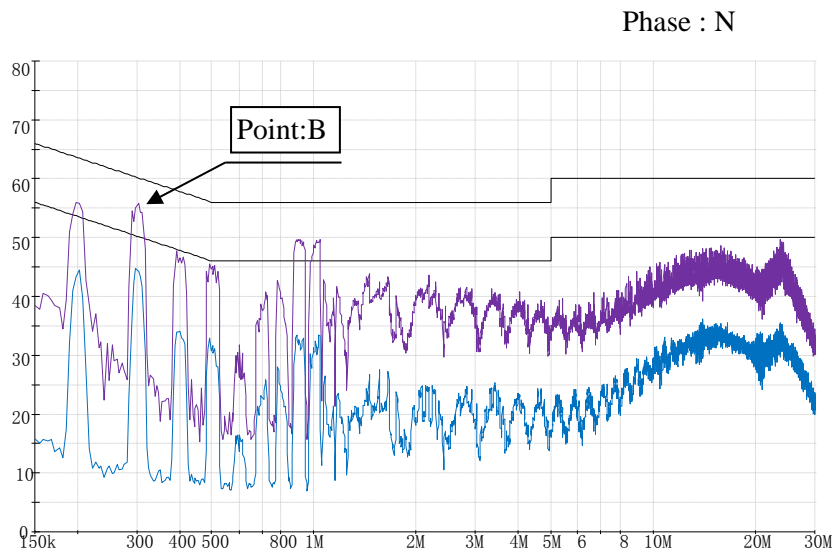

EN55032  
Class B  
QP Limit  
←  
←  
EN55032  
Class B  
AV Limit

EN55011-B,VCCI-B,FCC-Bの限界値はEN55032 class Bの限界値と同じ  
Limit of EN55011-B,VCCI-B,FCC-B are same as its EN55032 class B.

2.12 EMI 特性

Electro-Magnetic Interference characteristics

CUS30M

Conditions Vin : 115 VAC  
Iout : 100 %  
Ta : 25 °C

雑音電界強度

Radiated Emission (CLASS I)

12V

(CUS30M-12)

Point A (183.2MHz)		
Ref. Data	Limit (dBuV)	Measure (dBuV)
QP	40.0	20.2

HORIZONTAL

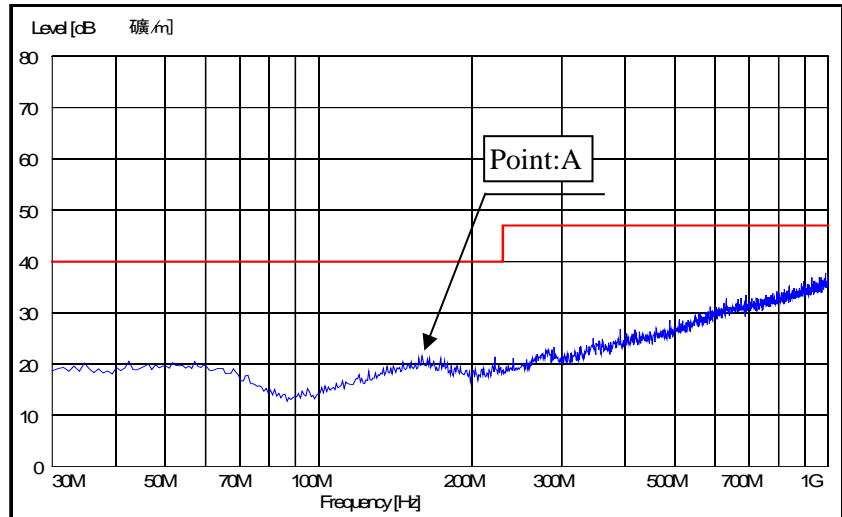

EN55032  
Class B  
QP Limit

Point B (34.7MHz)		
Ref. Data	Limit (dBuV)	Measure (dBuV)
QP	40.0	28.1

VERTICAL

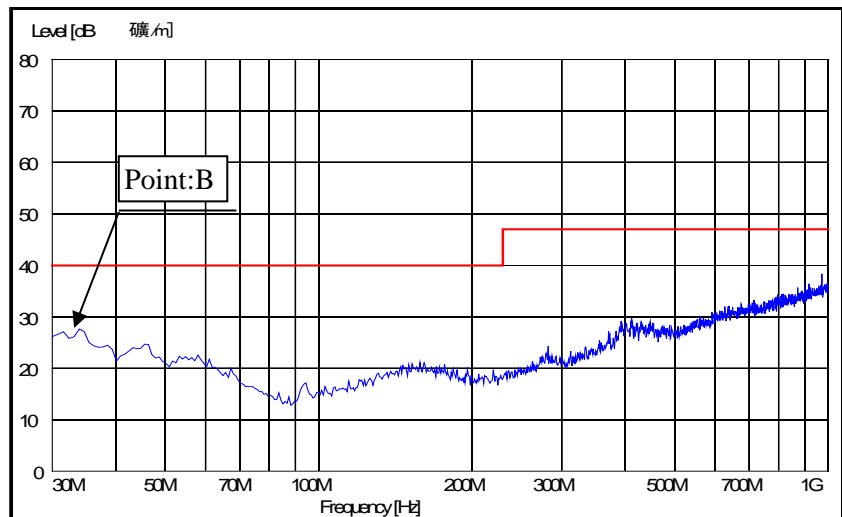

EN55032  
Class B  
QP Limit

2.12 EMI 特性

Electro-Magnetic Interference characteristics

CUS30M

Conditions Vin : 230 VAC  
Iout : 100 %  
Ta : 25 °C

雑音電界強度

Radiated Emission (CLASS I)

12V

(CUS30M-12)

Point A (182.4MHz)		
Ref. Data	Limit (dBuV)	Measure (dBuV)
QP	40.0	20.1

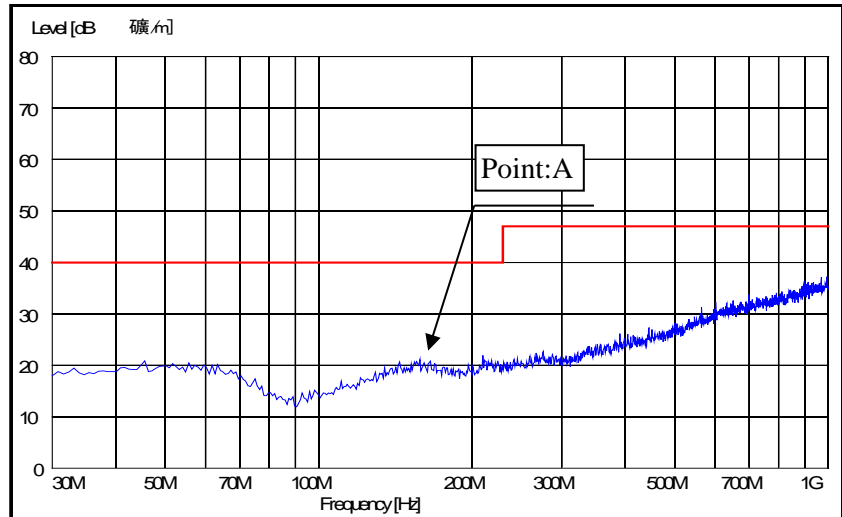

EN55032  
Class B  
QP Limit

Point B (30.6MHz)		
Ref. Data	Limit (dBuV)	Measure (dBuV)
QP	40.0	26.8

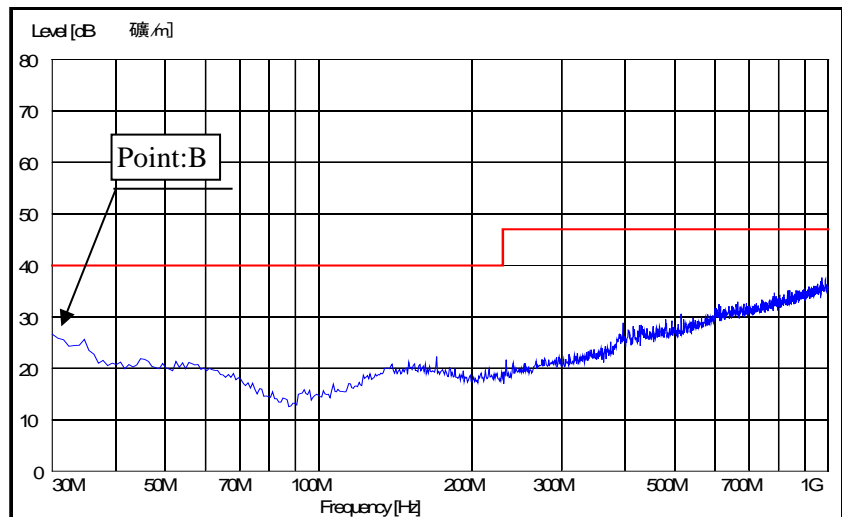

EN55032  
Class B  
QP Limit

2.12 EMI 特性

Electro-Magnetic Interference characteristics

CUS30M

Conditions Vin : 115 VAC  
Iout : 100 %  
Ta : 25 °C

雑音電界強度

Radiated Emission (CLASS II)

12V

(CUS30M-12)

Point A (183.3MHz)		
Ref. Data	Limit (dBuV)	Measure (dBuV)
QP	40.0	22.4

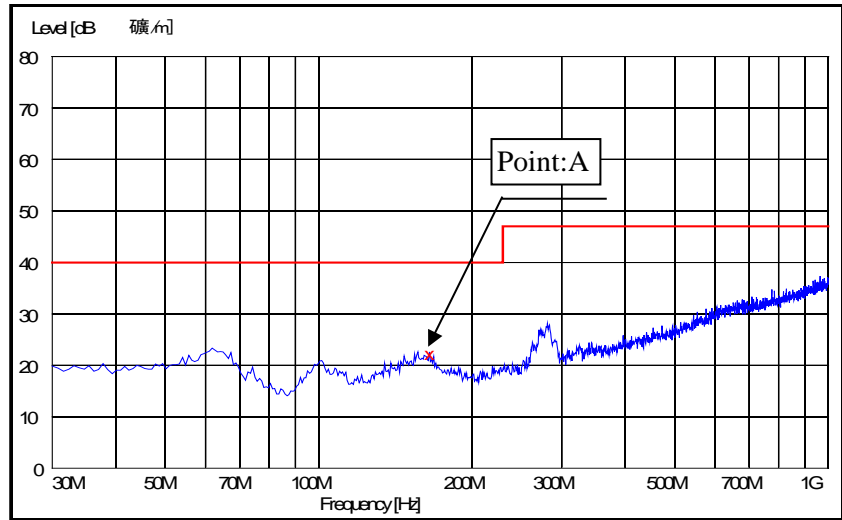

Point B (64.1MHz)		
Ref. Data	Limit (dBuV)	Measure (dBuV)
QP	40.0	32.0

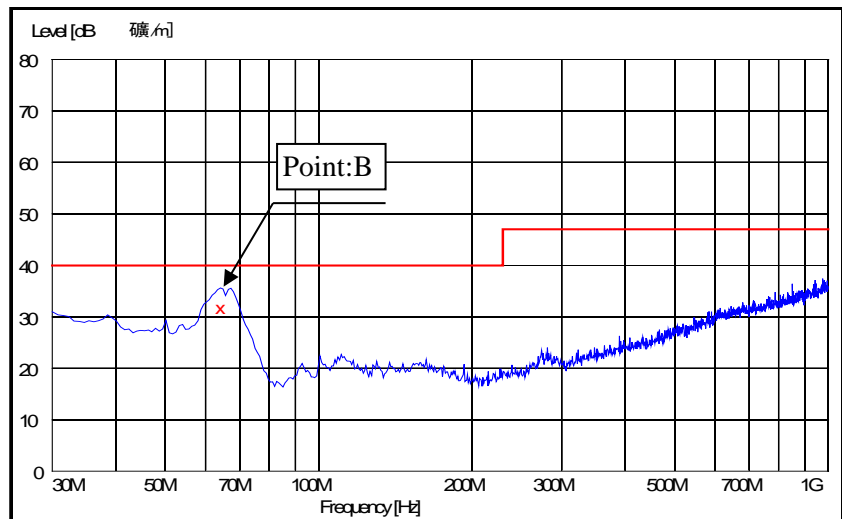



2.12 EMI 特性

Electro-Magnetic Interference characteristics

CUS30M

Conditions Vin : 230 VAC  
Iout : 100 %  
Ta : 25 °C

雑音電界強度

Radiated Emission (CLASS II)

12V

(CUS30M-12)

Point A (185.6MHz)		
Ref. Data	Limit (dBuV)	Measure (dBuV)
QP	40.0	22.9

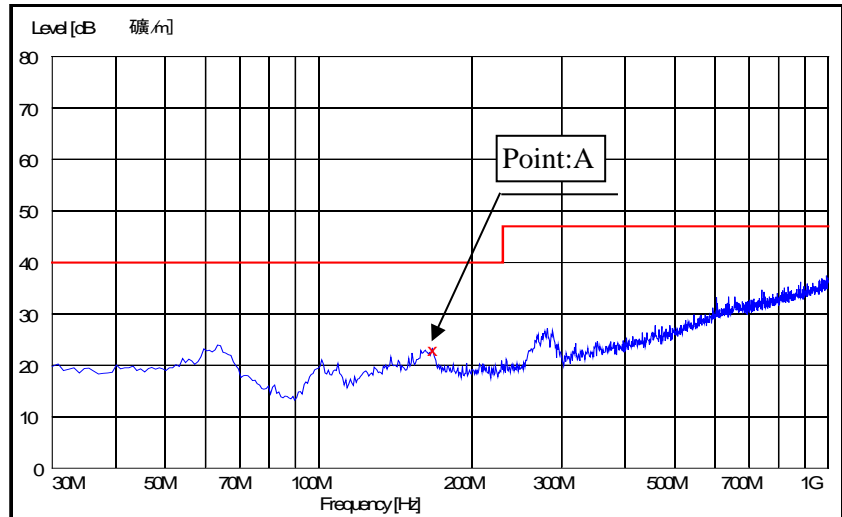

Point B (67.4MHz)		
Ref. Data	Limit (dBuV)	Measure (dBuV)
QP	40.0	33.2

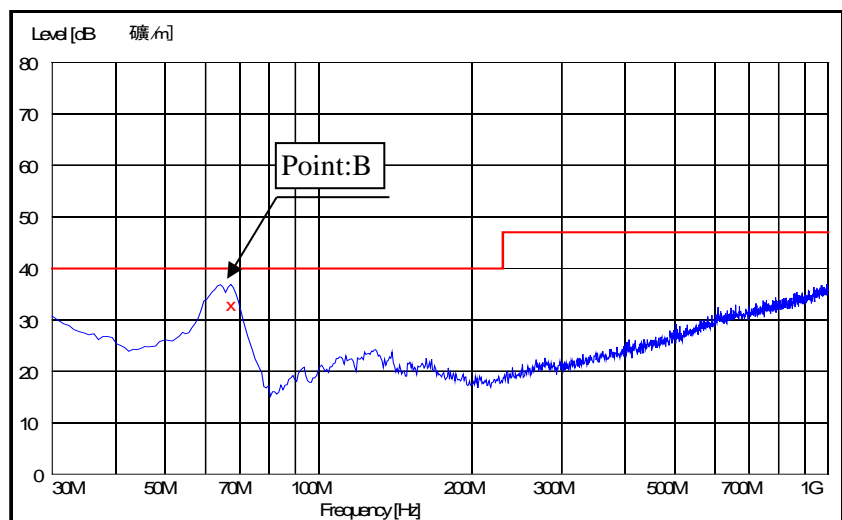

2.12 EMI 特性

Electro-Magnetic Interference characteristics

CUS30M

Conditions Vin : 115 VAC  
Iout : 100 %  
Ta : 25 °C

雑音電界強度

Radiated Emission (CLASS I)

24V

(CUS30M-24)

Point A (1000MHz)		
Ref. Data	Limit (dBuV)	Measure (dBuV)
QP	46.0	33.0

HORIZONTAL

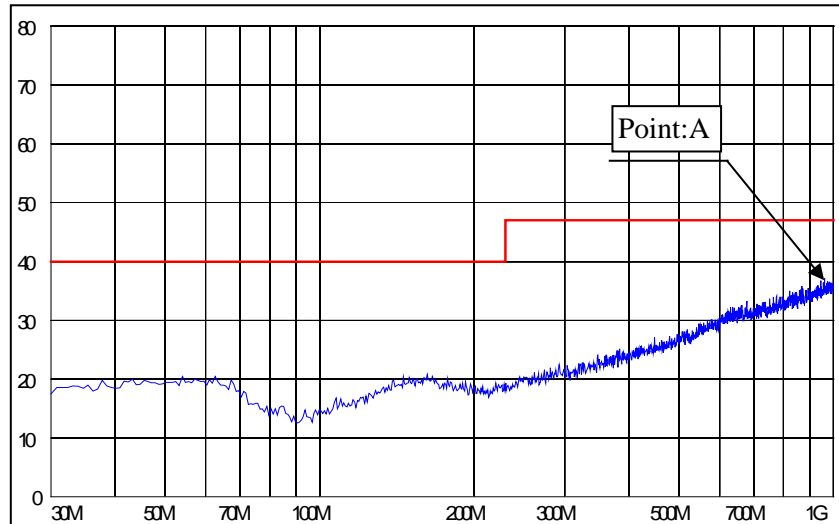

EN55032  
Class B  
QP Limit

Point B (1000MHz)		
Ref. Data	Limit (dBuV)	Measure (dBuV)
QP	46.0	33.0

VERTICAL

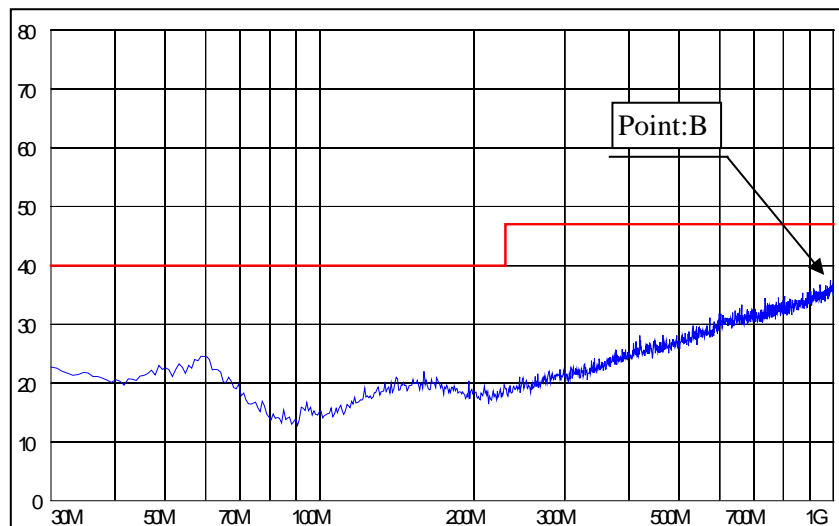

EN55032  
Class B  
QP Limit

2.12 EMI 特性

Electro-Magnetic Interference characteristics

CUS30M

Conditions Vin : 230 VAC  
Iout : 100 %  
Ta : 25 °C

雑音電界強度

Radiated Emission (CLASS I)

24V

(CUS30M-24)

		Point A (1000MHz)	
Ref.	Data	Limit (dBuV)	Measure (dBuV)
QP		46.0	33.0

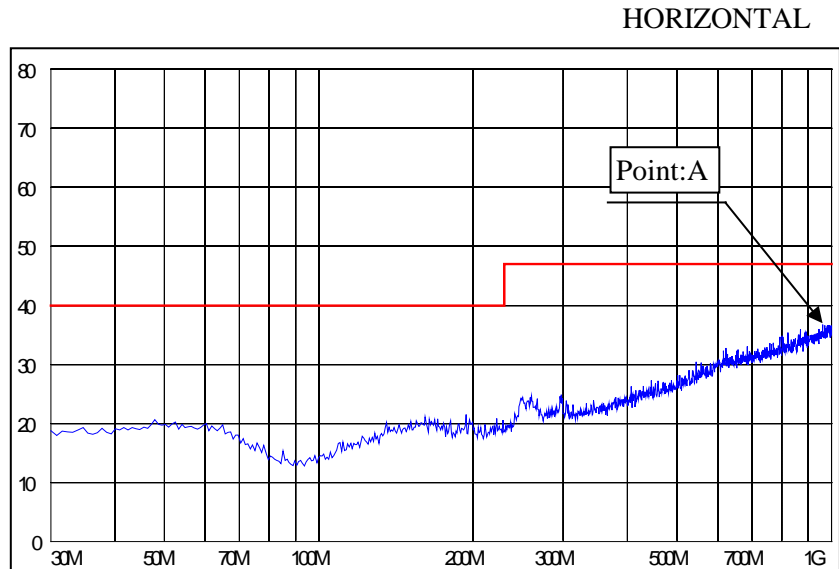

EN55032  
Class B  
QP Limit

		Point B (1000MHz)	
Ref.	Data	Limit (dBuV)	Measure (dBuV)
QP		46.0	33.0

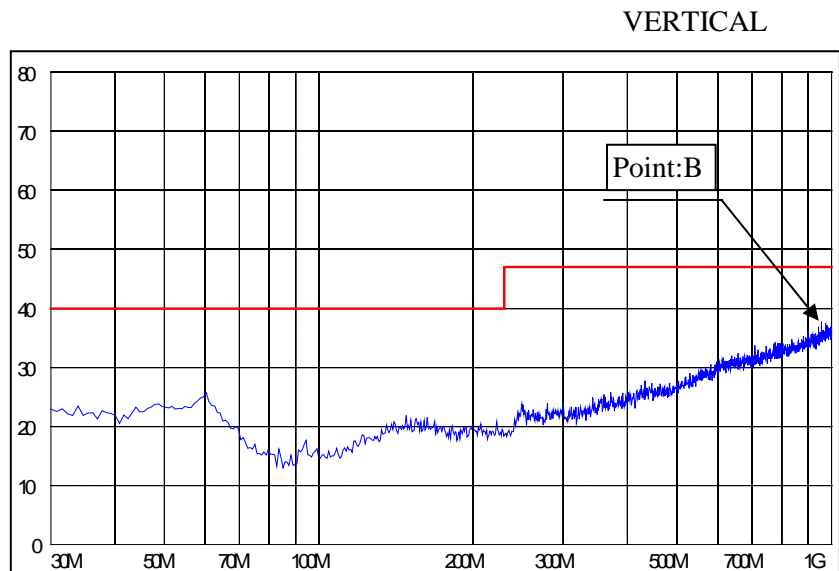

EN55032  
Class B  
QP Limit

2.12 EMI 特性

Electro-Magnetic Interference characteristics

CUS30M

Conditions Vin : 115 VAC  
Iout : 100 %  
Ta : 25 °C

雑音電界強度

Radiated Emission (CLASS II)

24V

(CUS30M-24)

Point A (200MHz)		
Ref. Data	Limit (dBuV)	Measure (dBuV)
QP	40.0	30.0

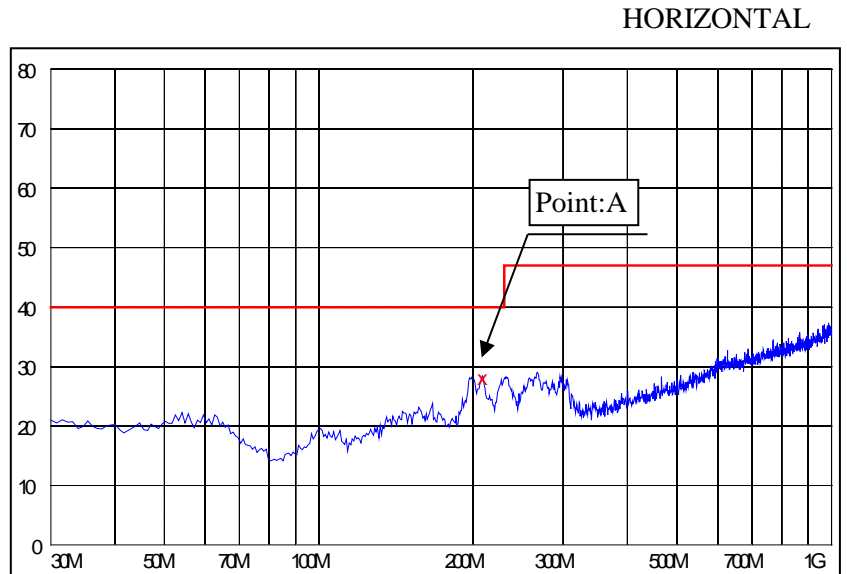

Point B (50MHz)		
Ref. Data	Limit (dBuV)	Measure (dBuV)
QP	40.0	34.0

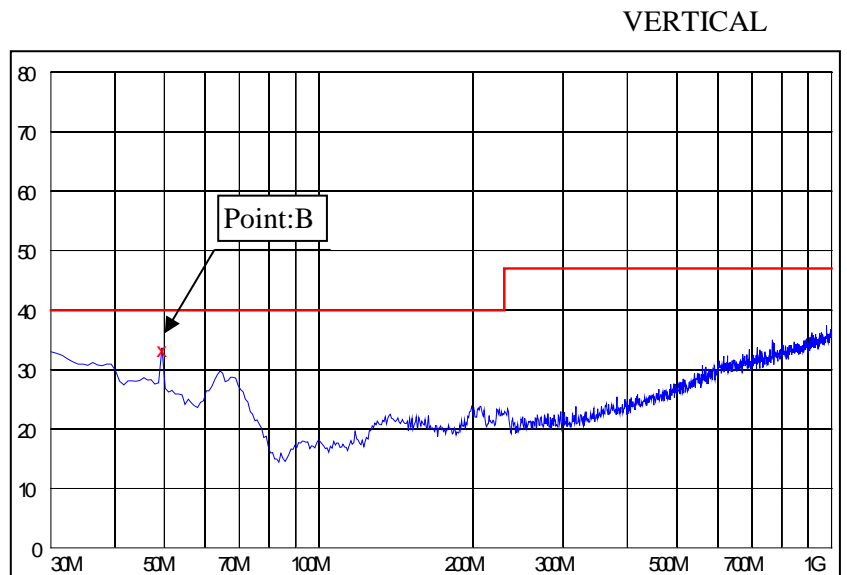

2.12 EMI 特性

Electro-Magnetic Interference characteristics

CUS30M

Conditions Vin : 230 VAC  
Iout : 100 %  
Ta : 25 °C

雑音電界強度

Radiated Emission (CLASS II)

24V

(CUS30M-24)

Point A (230MHz)		
Ref. Data	Limit (dBuV)	Measure (dBuV)
QP	40.0	27.0

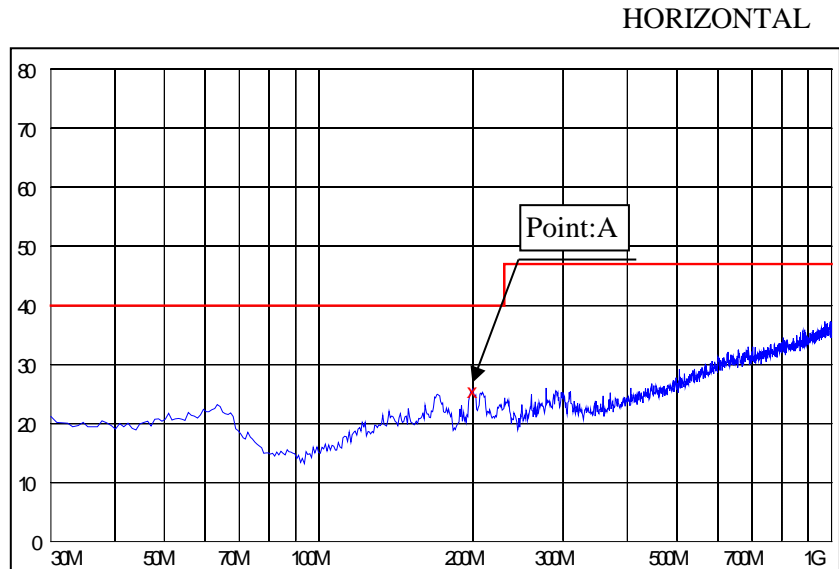

EN55032  
Class B  
QP Limit

Point B (60MHz)		
Ref. Data	Limit (dBuV)	Measure (dBuV)
QP	40.0	32.3

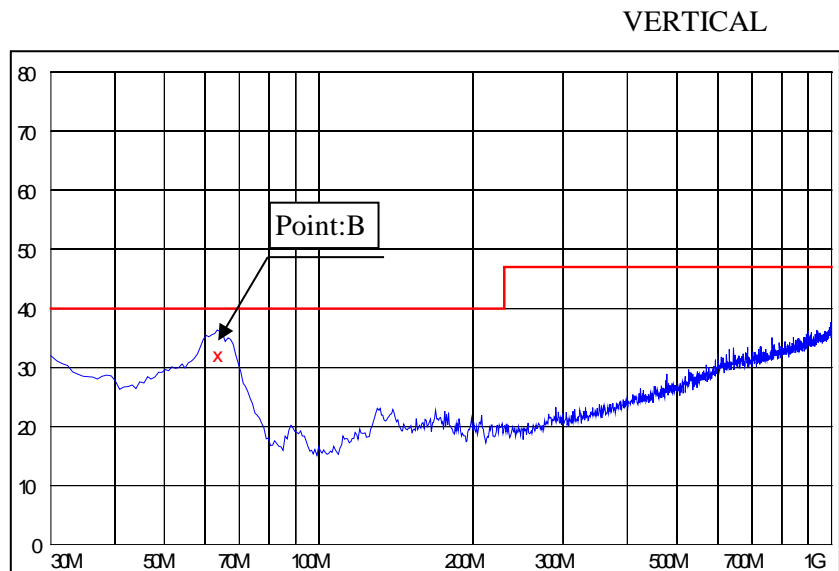

EN55032  
Class B  
QP Limit

2.12 EMI 特性

Electro-Magnetic Interference characteristics

CUS30M

Conditions Vin : 115 VAC  
Iout : 100 %  
Ta : 25 °C

雑音電界強度

Radiated Emission (CLASS I)

48V

(CUS30M-48)

Point A (1000MHz)		
Ref. Data	Limit (dBuV)	Measure (dBuV)
QP	47.0	35.5

HORIZONTAL

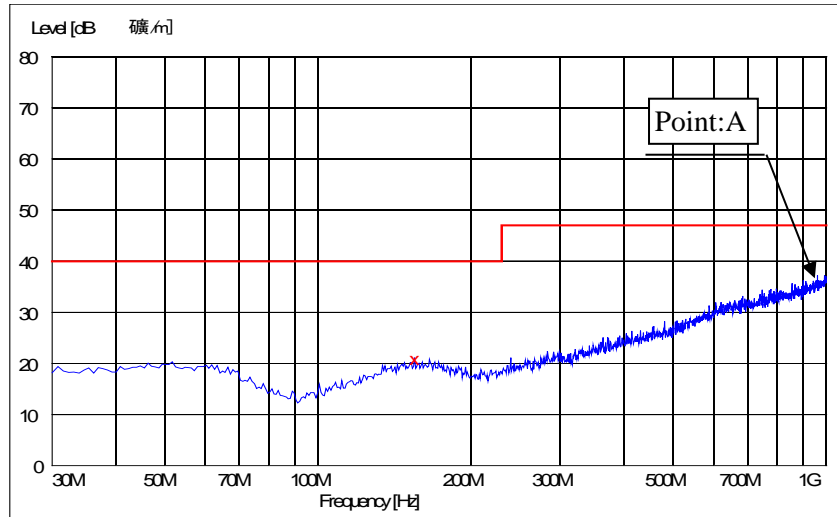

Point B (1000MHz)		
Ref. Data	Limit (dBuV)	Measure (dBuV)
QP	47.0	35.0

VERTICAL

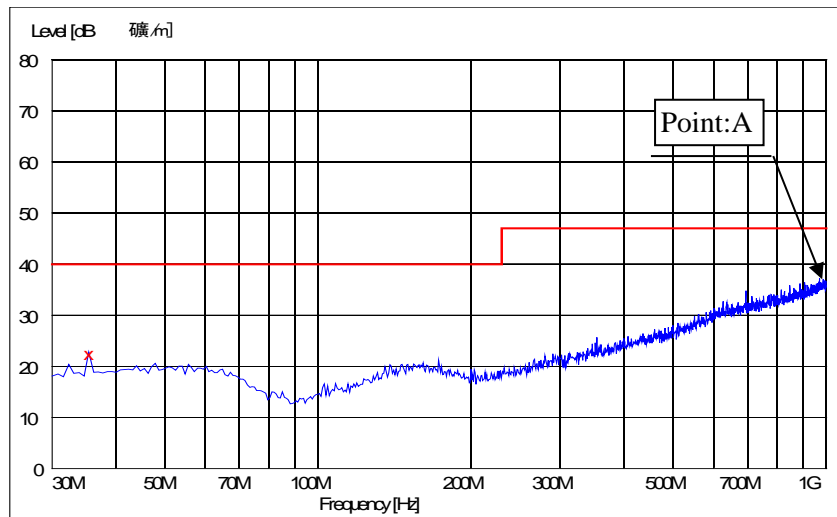

2.12 EMI 特性

Electro-Magnetic Interference characteristics

CUS30M

Conditions Vin : 230 VAC  
Iout : 100 %  
Ta : 25 °C

雑音電界強度

Radiated Emission (CLASS I)

48V

(CUS30M-48)

Point A (1000MHz)		
Ref. Data	Limit (dBuV)	Measure (dBuV)
QP	47.0	36.0

HORIZONTAL

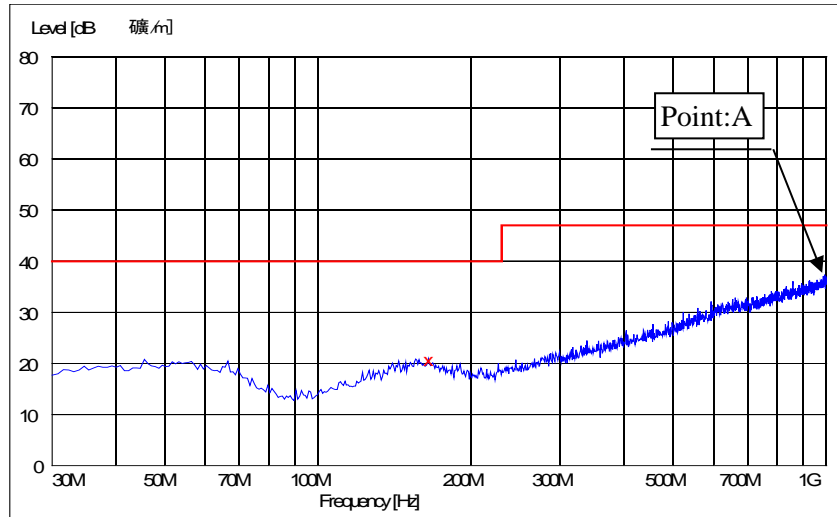

Point B (1000MHz)		
Ref. Data	Limit (dBuV)	Measure (dBuV)
QP	47.0	36.0

VERTICAL

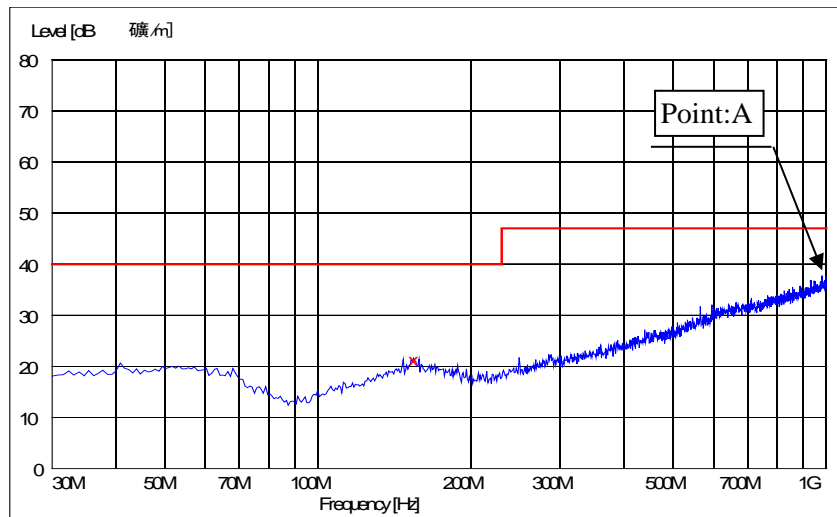

2.12 EMI 特性

Electro-Magnetic Interference characteristics

CUS30M

Conditions Vin : 115 VAC  
Iout : 100 %  
Ta : 25 °C

雑音電界強度

Radiated Emission (CLASS II)

48V

(CUS30M-48)

Point A (175MHz)		
Ref. Data	Limit (dBuV)	Measure (dBuV)
QP	40.0	35.0

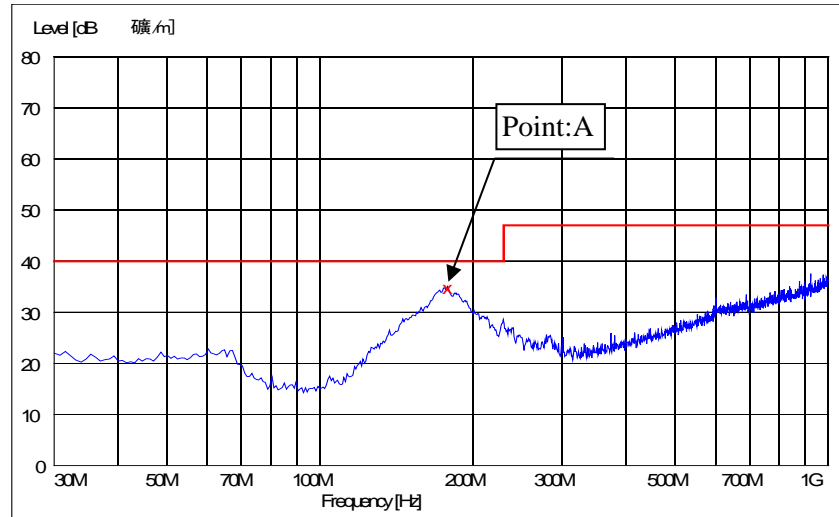

Point B (175MHz)		
Ref. Data	Limit (dBuV)	Measure (dBuV)
QP	40.0	35.4

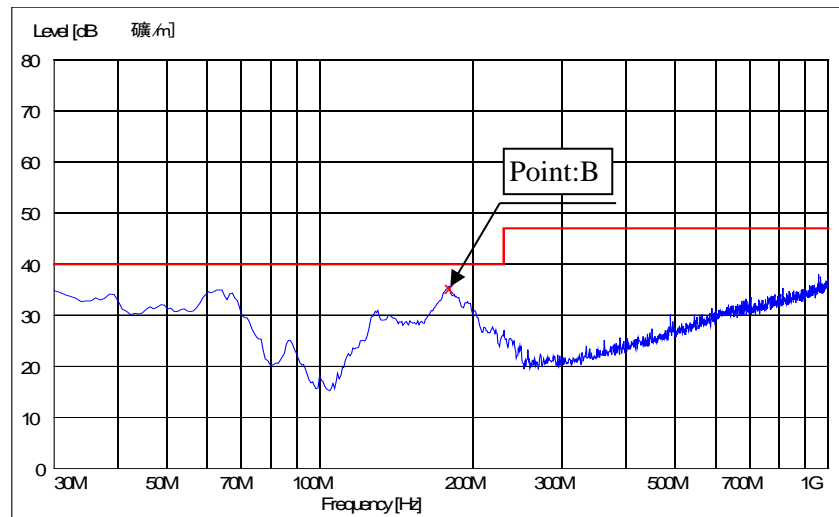



2.12 EMI 特性

Electro-Magnetic Interference characteristics

CUS30M

Conditions Vin : 230 VAC  
Iout : 100 %  
Ta : 25 °C

雑音電界強度

Radiated Emission (CLASS II)

48V

(CUS30M-48)

Point A (172MHz)		
Ref. Data	Limit (dBuV)	Measure (dBuV)
QP	40.0	31.2

HORIZONTAL

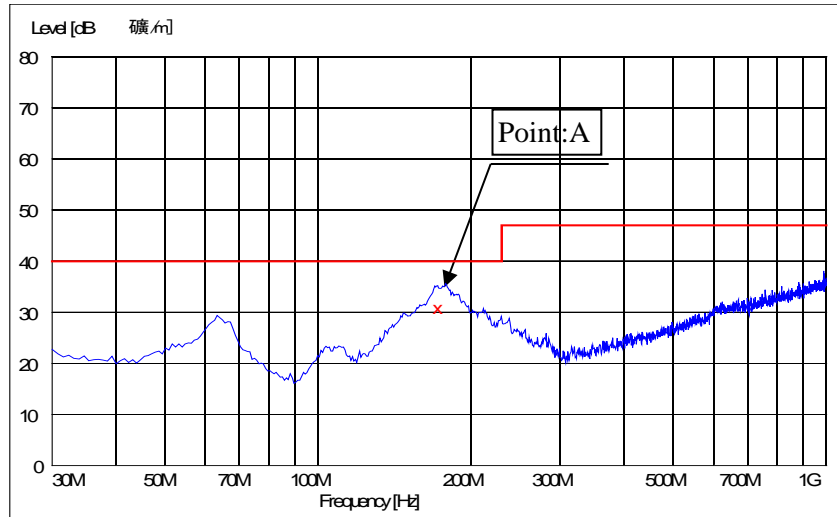

EN55032  
Class B  
QP Limit

Point B (63MHz)		
Ref. Data	Limit (dBuV)	Measure (dBuV)
QP	40.0	36.9

VERTICAL

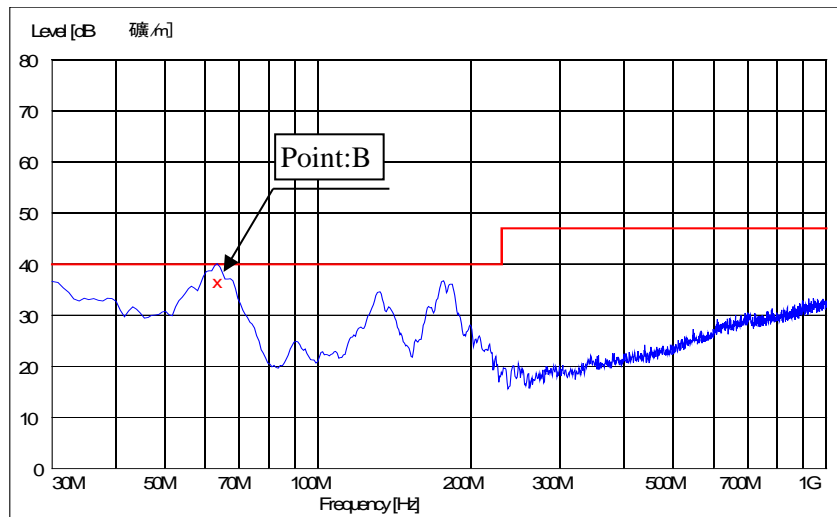

EN55032  
Class B  
QP Limit