

CUS800M

EVALUATION DATA

INDEX

1. Evaluation Method	PAGE
1-1. Circuit used for determination	
Circuit 1 used for determination	3
Steady state data	
Warm up voltage drift characteristics	
Hold up time characteristics	
Output rise characteristics	
Output fall characteristics	
Over current protection (OCP) characteristics	
Over voltage protection (OVP) characteristics	
Response to brown out characteristics	
Various signal	
Circuit 2 used for determination	3
Dynamic load response characteristics	
Circuit 3 used for determination	4
Inrush current waveform	
Circuit 4 used for determination	4
Earth leakage current characteristics	
Patient current characteristics	
Circuit 5 used for determination	5
Output ripple and noise waveform	
Configuration used for determination	5
Electro-Magnetic Interference characteristics	
(a) Conducted EMIssion	
(b) Radiated EMIssion	
1-2. List of equipment used	6
1-3. Load conditions	6

2. Characteristics	PAGE
2-1. Steady state data	
(1) Regulation - line and load, Temperature drift / Start up voltage and Drop out voltage	7~8
(2) Efficiency and Power factor vs. Output current	9
(3) Input power vs. Output current	10
(4) Input current vs. Output current	11
(5) Input power vs. Output current @ Remote OFF	12
2-2. Warm up voltage drift characteristics	13
2-3. Hold up time characteristics	13
2-4. Output rise characteristics	14~15
2-5. Output fall characteristics	16~17
2-6. Various signal	18
2-7. Over current protection (OCP) characteristics	19
2-8. Over voltage protection (OVP) characteristics	20
2-9. Dynamic load response characteristics	21~22
2-10. Response to brown out characteristics	23~24
2-11. Inrush current waveform	25
2-12. Input current harmonics	26
2-13. Leakage current characteristics	27~28
2-14. Output ripple and noise waveform	29
2-15. Electro-Magnetic Interference characteristics	30~45
2-16. Audible Noise of FAN	46

Terminology used

	Definition
V_{in}	Input voltage
V_{out}	Output voltage
I_{in}	Input current
I_{out}	Output current
T_a	Ambient temperature
f	Frequency
PG	Power good signal
V_{stb}	Output voltage of standby
I_{stb}	Output current of standby

※ Test results are reference data based on our measurement condition.

1. Evaluation Method

1-1. Circuit used for determination

Circuit 1 used for determination

- Steady state data
- Warm up voltage drift characteristics
- Hold up time characteristics
- Output rise characteristics
- Output fall characteristics
- Over current protection (OCP) characteristics
- Over voltage protection (OVP) characteristics
- Response to brown out characteristics
- Various signal

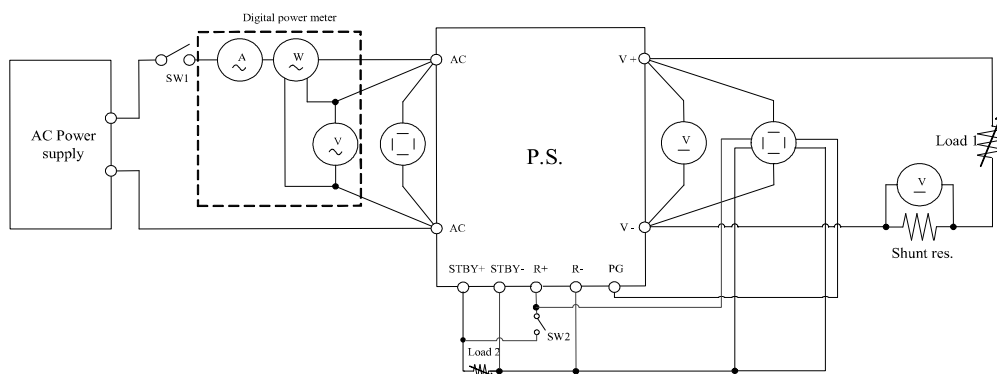

Circuit 2 used for determination

- Dynamic load response characteristics

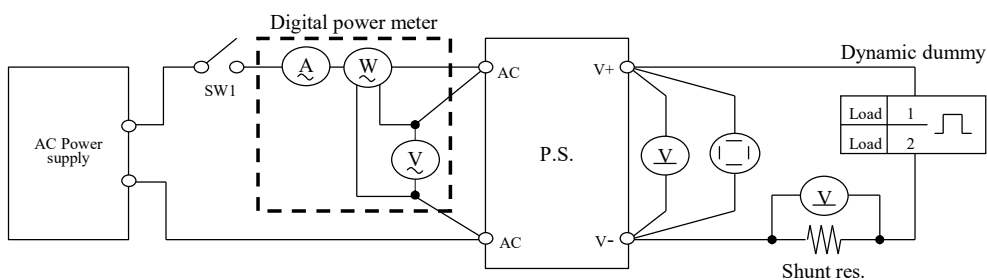

Output current waveform
I_{out} 50% \rightleftharpoons 100%

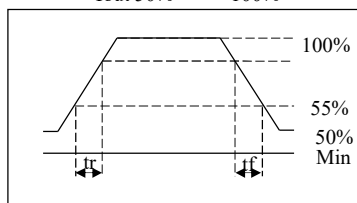

Circuit 3 used for determination

- Inrush current waveform

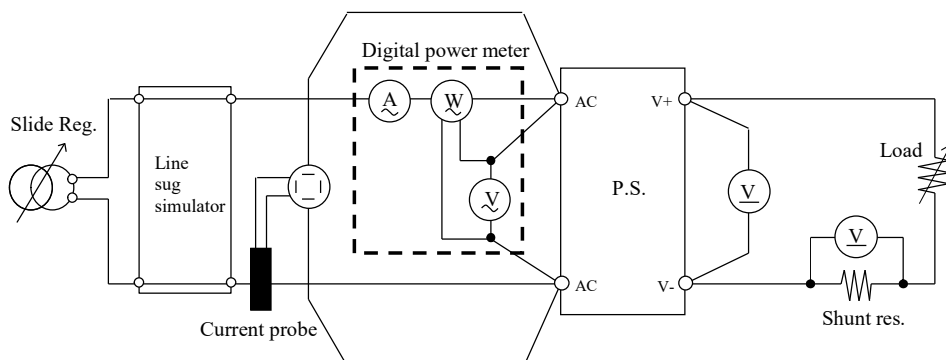

Circuit 4 used for determination

- Earth leakage current characteristics

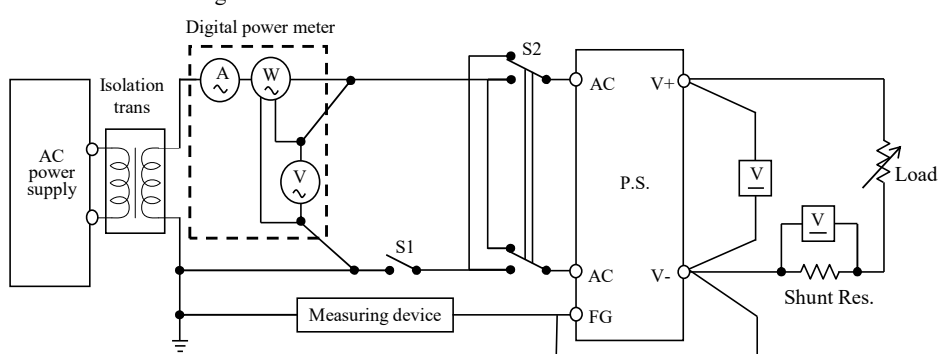

Measure in all possible combination of position of S2 with :
S1 closed (normal condition), and S1 open (single fault condition).

- Patient leakage current

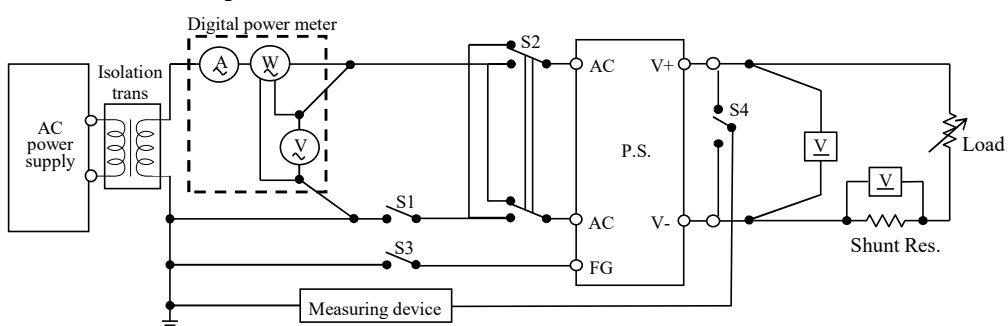

CLASS I equipment:

S1, S3 closed, measure under all possible position of S2 & S4.

Single fault condition: S1 open with S3 close or S1 close with S3 open.

Circuit 5 used for determination

- Output ripple and noise waveform

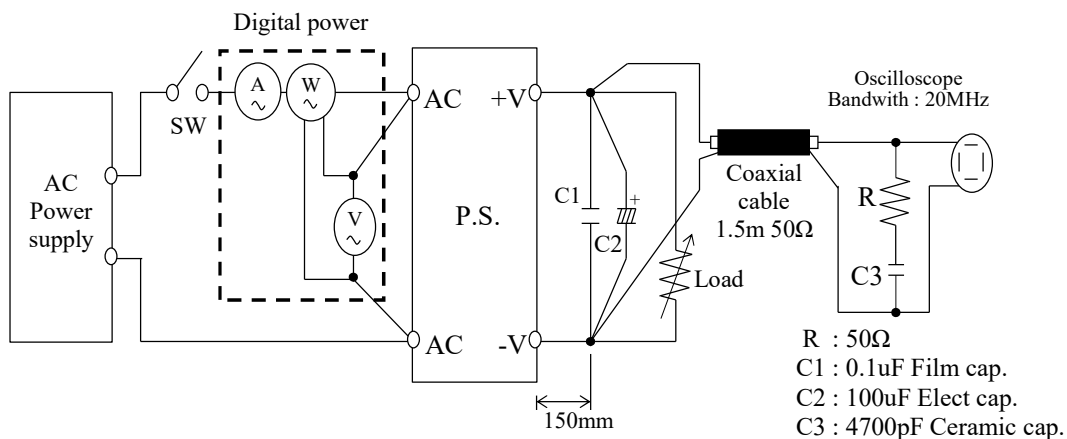

Configuration used for determination

- Electro-Magnetic Interference characteristics

(a) Conducted Emission

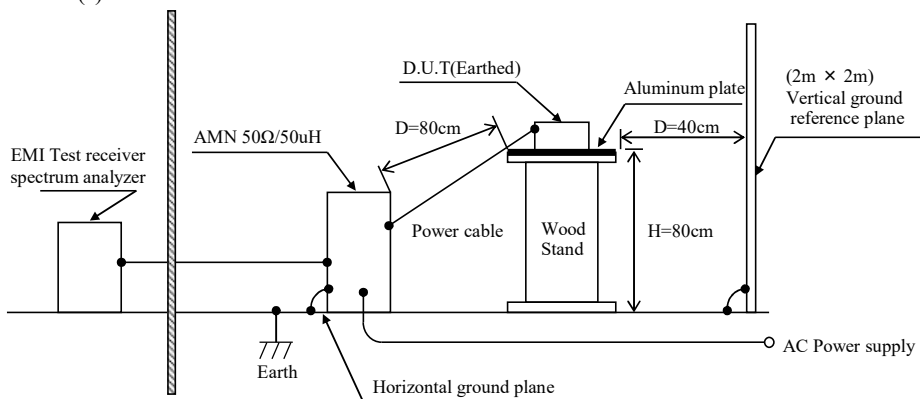

(b) Radiated Emission

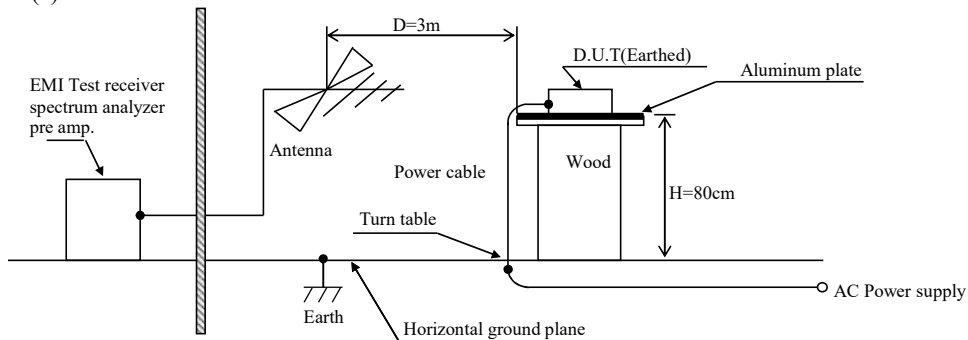

1-2. List of equipment used

	EQUIPMENT USED	MANUFACTURER	MODEL NO.
1	DIGITAL STORAGE OSCILLOSCOPE	YOKOGAWA ELECT.	DLM2054
2	DIGITAL MULTIMETER	KEYSIGHT	34970A
3	DIGITAL POWER METER	YOKOGAWA ELECT.	WT310
4	CURRENT PROBE	YOKOGAWA ELECT.	701930
5	POWER SUPPLY	YOKOGAWA ELECT.	701934
6	DYNAMIC DUMMY LOAD	CHROMA	63030/63203A/63640
7	AC SOURCE	KIKUSUI	PCR4000LE
8	EARTH LEAKAGE CURRENT METER	SIMPSON	228
9	PATIENT LEAKAGE CURRENT METER	SIQ	SIQ16042
10	CONTROLLED TEMP. CHAMBER	TABAI-ESPEC	SH-662
11	EMI TEST RECEIVER	ROHDE & SCHWARZ	ESR3
12	LISN	ROHDE & SCHWARZ	ENV216
13	BROADBAND ANTENNA	SCHWARZBECK	VULB9163
14	LINE SUG SIMULATOR	TAKAMISAWA	PSA-210
15	SOUND CALIBRATOR	BRUEL AND KJAER	TYPE 4231
16	AUDIO ANALYZER	BRUEL AND KJAER	TYPE 3560-C

1-3. Load conditions

Vin	Iout	12V	24V	36V	48V
85 - 265VAC	50%	28.35A	16.7A	11.1A	8.35A
85VAC	90%	51.03A	30.06A	19.98A	15.03A
90 - 265VAC	100%	56.7A	33.4A	22.2A	16.7A
85 - 265VAC	50%Peak	33.35A	16.7A	11.1A	8.35A
85 - 265VAC	Peak	66.7A	33.4A	22.2A	16.7A

*Vstb=5V, Istb=2A(100%)

2. Characteristics

2-1. Steady state data

(1) Regulation - line and load, Temperature drift / Start up voltage and Drop out voltage

12V 1. Regulation - line and load

Condition Ta : 25 °C
Iout : 100 % (56.7A)
Istb : 0 %

Iout \ Vin	85VAC	115VAC	230VAC	265VAC	Line regulation	
0%	12.028V	12.025V	12.025V	12.024V	4mV	0.033%
50%	12.010V	12.010V	12.010V	12.009V	1mV	0.008%
100%	-	11.996V	11.996V	11.996V	0mV	0.000%
Peak	-	11.976V	11.976V	11.976V	0mV	0.000%
Load	18mV	29mV	29mV	28mV		
regulation	0.150%	0.242%	0.242%	0.233%		

2. Temperature drift

Condition Vin : 115 VAC
Iout : 100 % (56.7A)
Istb : 0 %

Ta	-20°C	+25°C	+55°C	Temperature stability	
Vout	11.987V	11.996V	11.996V	9mV	0.075%

3. Start up voltage and Drop out voltage

Condition Ta : 25 °C
Iout : Peak (66.7A)
Istb : 0 %

Start up voltage (Vin)	79.2VAC
Drop out voltage (Vin)	77.8VAC

24V 1. Regulation - line and load

Condition Ta : 25 °C
Iout : 100 % (33.4A)
Istb : 0 %

Iout \ Vin	85VAC	115VAC	230VAC	265VAC	Line regulation	
0%	24.048V	24.045V	24.046V	24.044V	4mV	0.017%
50%	24.025V	24.024V	24.025V	24.024V	1mV	0.004%
100%	-	24.017V	24.017V	24.016V	1mV	0.004%
Load	23mV	28mV	29mV	28mV		
regulation	0.096%	0.117%	0.121%	0.117%		

2. Temperature drift

Condition Vin : 115 VAC
Iout : 100 % (33.4A)
Istb : 0 %

Ta	-20°C	+25°C	+55°C	Temperature stability	
Vout	23.985V	24.017V	24.022V	37mV	0.154%

3. Start up voltage and Drop out voltage

Condition Ta : 25 °C
Iout : 100 % (33.4A)
Istb : 0 %

Start up voltage (Vin)	79.1VAC
Drop out voltage (Vin)	78.0VAC

(1) Regulation - line and load, Temperature drift / Start up voltage and Drop out voltage

36V 1. Regulation - line and load

Condition Ta : 25 °C
Iout : 100 % (22.2A)
Istb : 0 %

Iout \ Vin	85VAC	115VAC	230VAC	265VAC	Line regulation	
0%	36.084V	36.085V	36.052V	36.080V	33mV	0.092%
50%	36.045V	36.045V	36.045V	36.045V	0mV	0.000%
100%	-	36.037V	36.037V	36.037V	0mV	0.000%
Load regulation	39mV	48mV	15mV	43mV		
	0.108%	0.133%	0.042%	0.119%		

2. Temperature drift

Condition Vin : 115 VAC
Iout : 100 % (22.2A)
Istb : 0 %

Ta	-20°C	+25°C	+55°C	Temperature stability	
Vout	36.002V	36.037V	36.036V	35mV	0.097%

3. Start up voltage and Drop out voltage

Conc Ta : 25 °C
Iout : 100 % (22.2A)
Istb : 0 %

Start up voltage (Vin)	78.7VAC
Drop out voltage (Vin)	77.8VAC

48V 1. Regulation - line and load

Condition Ta : 25 °C
Iout : 100 % (16.7A)
Istb : 0 %

Iout \ Vin	85VAC	115VAC	230VAC	265VAC	Line regulation	
0%	48.081V	48.094V	48.094V	48.082V	13mV	0.027%
50%	48.039V	48.039V	48.039V	48.038V	1mV	0.002%
100%	-	48.032V	48.032V	48.032V	0mV	0.000%
Load regulation	42mV	62mV	62mV	50mV		
	0.088%	0.129%	0.129%	0.104%		

2. Temperature drift

Condition Vin : 115 VAC
Iout : 100 % (16.7A)
Istb : 0 %

Ta	-20°C	+25°C	+55°C	Temperature stability	
Vout	47.976V	48.032V	48.044V	68mV	0.142%

3. Start up voltage and Drop out voltage

Condition Ta : 25 °C
Iout : 100 % (16.7A)
Istb : 0 %

Start up voltage (Vin)	79.4VAC
Drop out voltage (Vin)	78.3VAC

(2) Efficiency and Power factor vs. Output current

Conditions Vin : 85 VAC ---
 115 VAC - - -
 230 VAC ---
 265 VAC - - -
 Ta : 25 °C
 Istb : 0 %

12V

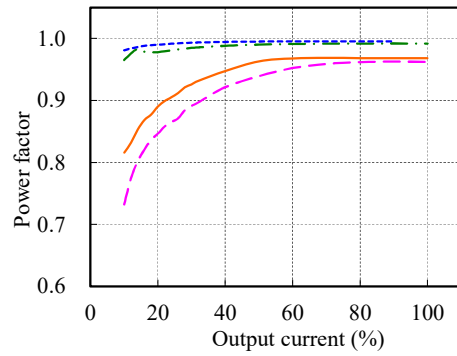
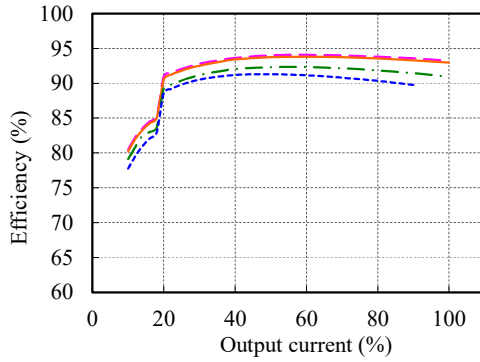

24V

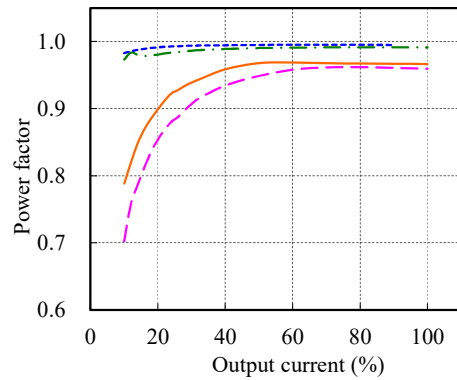
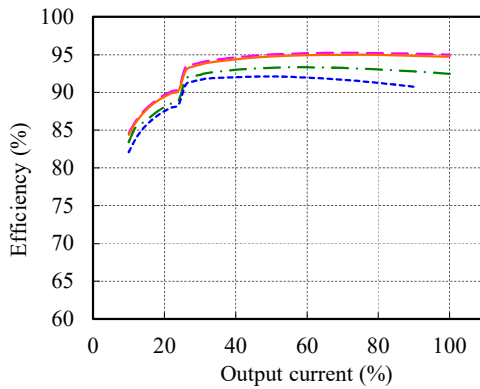

36V

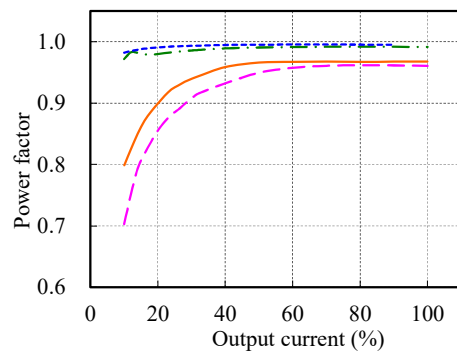
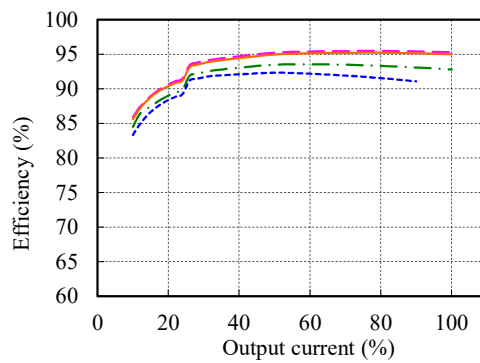

48V

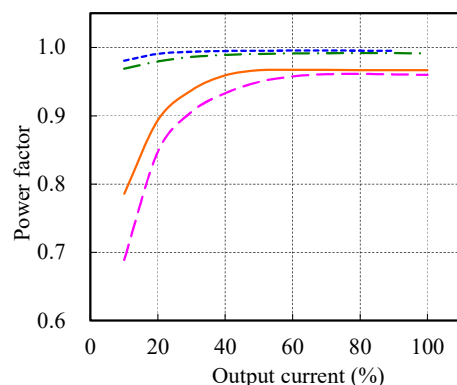
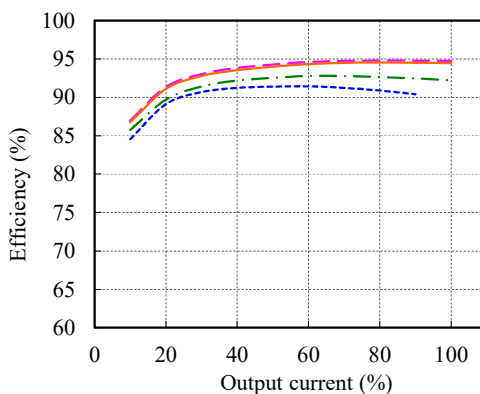

(3) Input power vs. Output current

Conditions Vin : 85 VAC ---
 115 VAC -.-
 230 VAC ---
 265 VAC -.-
 Ta : 25 °C
 Istb : 0 %

12V

Vin	Input power	
	Iout : 0%	Remote OFF
85VAC	4.4W	0.30W
115VAC	4.4W	0.34W
230VAC	3.2W	0.60W
265VAC	3.5W	0.72W

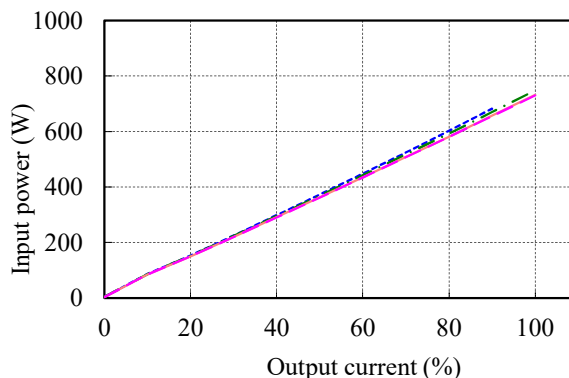

24V

Vin	Input power	
	Iout : 0%	Remote OFF
85VAC	4.7W	0.30W
115VAC	5.0W	0.34W
230VAC	3.9W	0.60W
265VAC	3.9W	0.72W

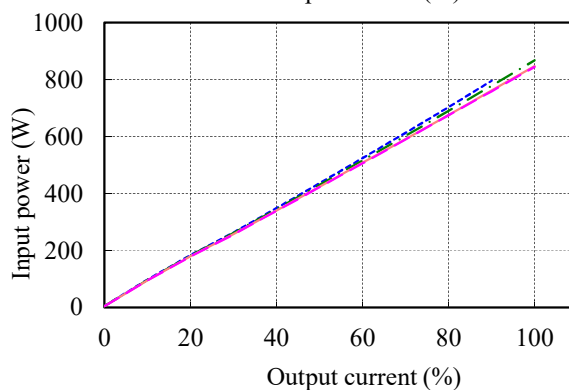

36V

Vin	Input power	
	Iout : 0%	Remote OFF
85VAC	5.0W	0.31W
115VAC	5.4W	0.34W
230VAC	4.0W	0.61W
265VAC	4.0W	0.73W

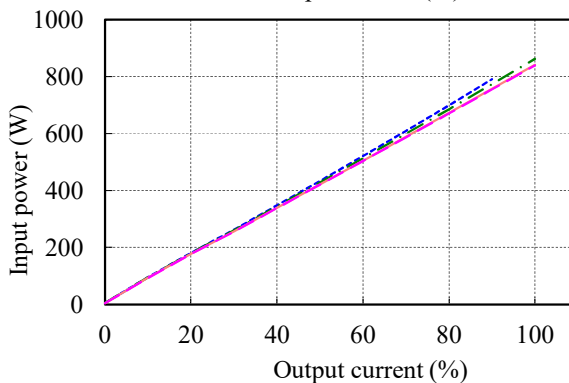

48V

Vin	Input power	
	Iout : 0%	Remote OFF
85VAC	5.6W	0.30W
115VAC	5.8W	0.34W
230VAC	4.4W	0.60W
265VAC	4.4W	0.72W

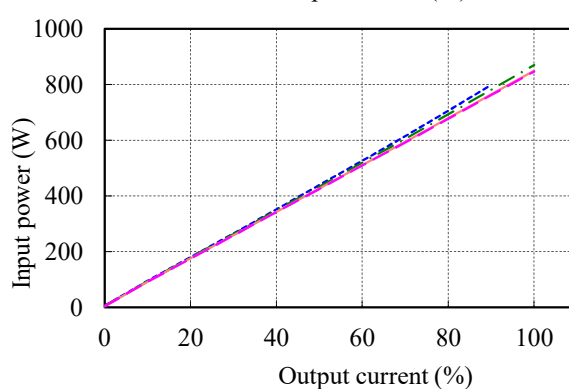

(4) Input current vs. Output current

Conditions Vin : 85 VAC ---
 115 VAC -.-
 230 VAC —
 265 VAC -.-
 Ta : 25 °C
 Istb : 0 %

12V

Vin	Input current	
	Iout : 0%	Remote OFF
85VAC	0.09A	0.04A
115VAC	0.09A	0.05A
230VAC	0.12A	0.11A
265VAC	0.14A	0.12A

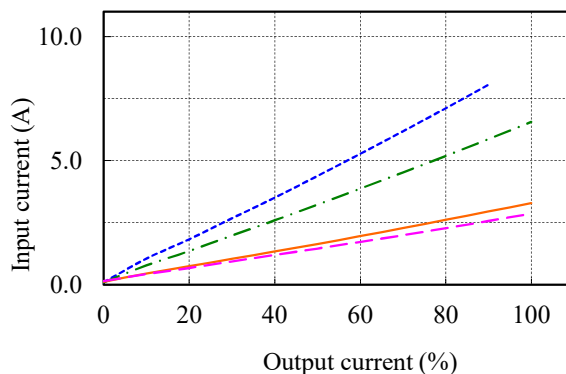

24V

Vin	Input current	
	Iout : 0%	Remote OFF
85VAC	0.10A	0.04A
115VAC	0.10A	0.05A
230VAC	0.12A	0.11A
265VAC	0.15A	0.12A

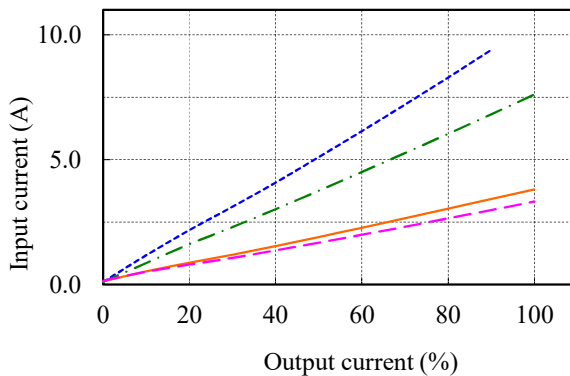

36V

Vin	Input current	
	Iout : 0%	Remote OFF
85VAC	0.10A	0.04A
115VAC	0.10A	0.05A
230VAC	0.12A	0.11A
265VAC	0.15A	0.12A

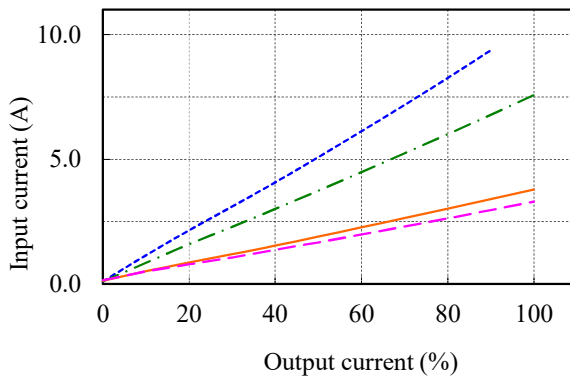

48V

Vin	Input current	
	Iout : 0%	Remote OFF
85VAC	0.11A	0.04A
115VAC	0.11A	0.05A
230VAC	0.13A	0.11A
265VAC	0.15A	0.12A

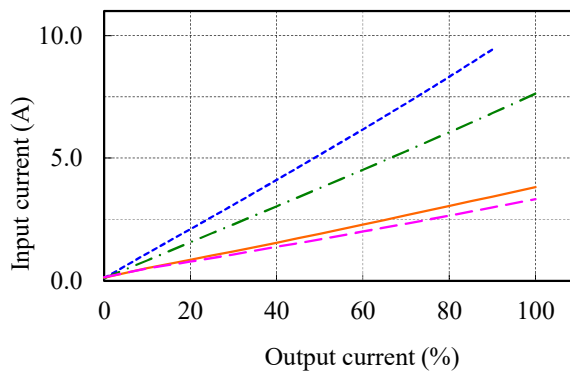

(5) Input power vs. Output current @ Remote OFF

Condition : Remote OFF

Istb Vs Pin @ 115VAC

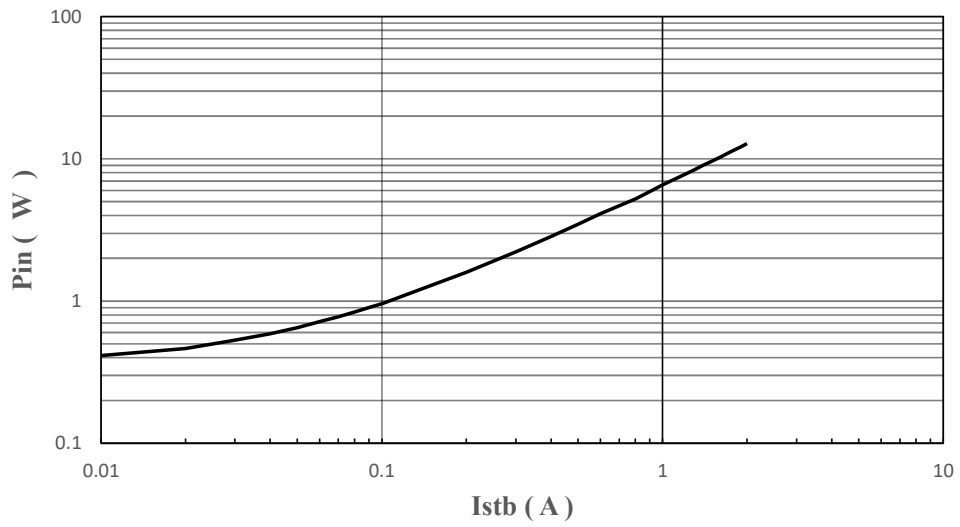

Istb Vs Pin @ 230VAC

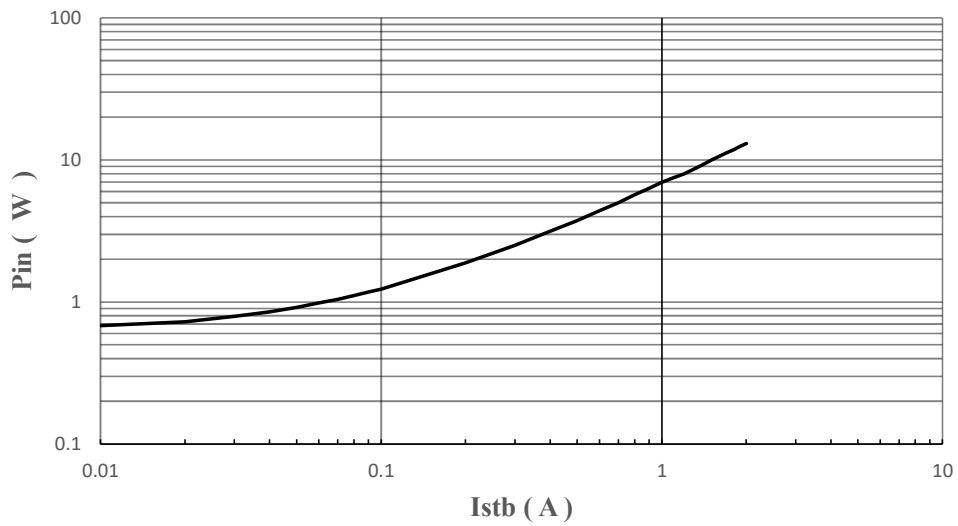

2-2. Warm up voltage drift characteristics

Conditions V_{in} : 115 VAC
 I_{out} : 100 %
 T_a : 25 °C
 I_{stb} : 100%

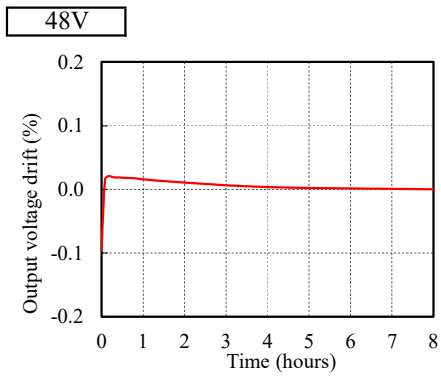
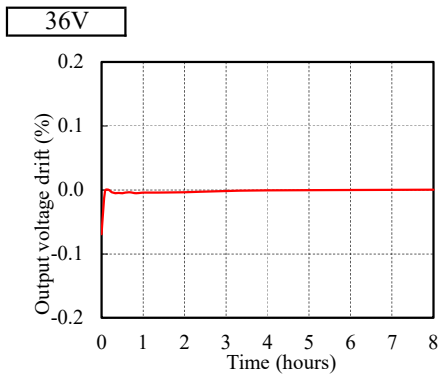
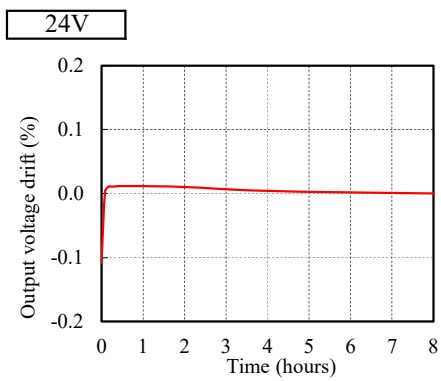
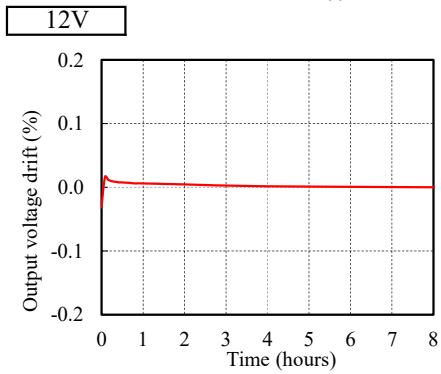

2-3. Hold up time characteristics

Conditions V_{in} : 115 VAC ———
 230 VAC - - - -
 T_a : 25 °C
 I_{stb} : 100%

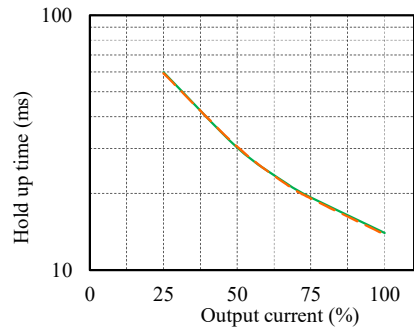
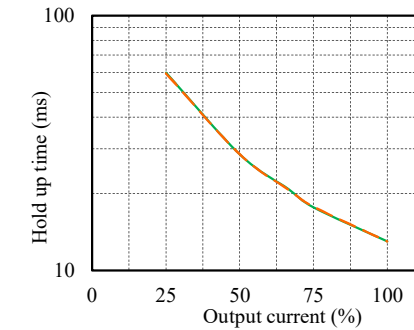
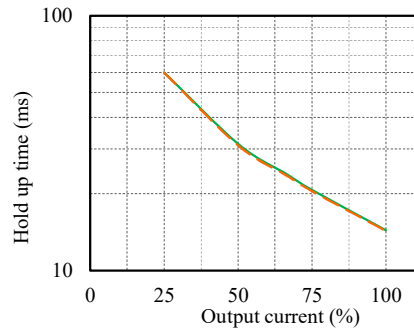
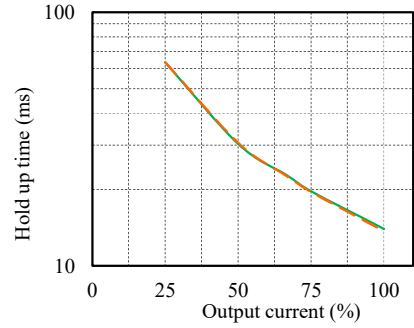

2-4. Output rise characteristics

Conditions Vin : 85 VAC (A)
 115 VAC (B)
 230 VAC (C)
 265 VAC (D)
 Istb : 100 %
 Ta : 25 °C

12V

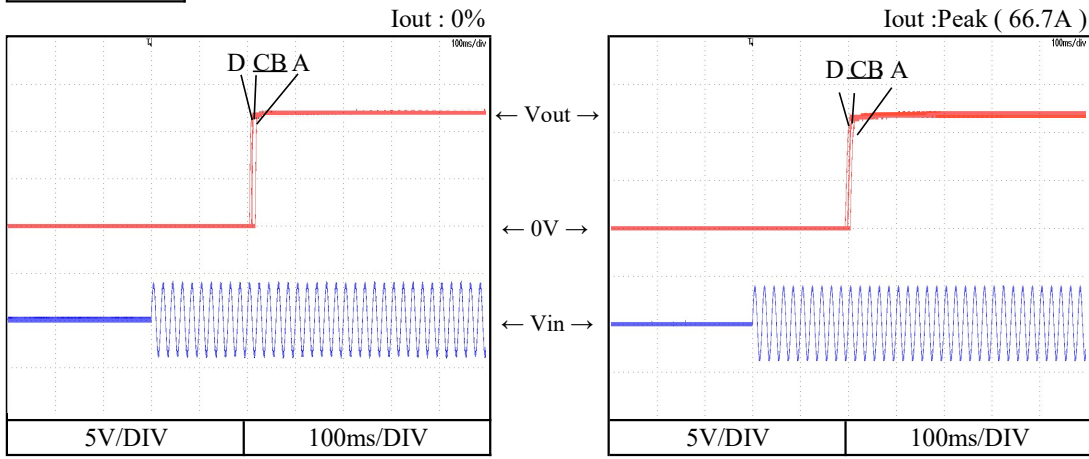

24V

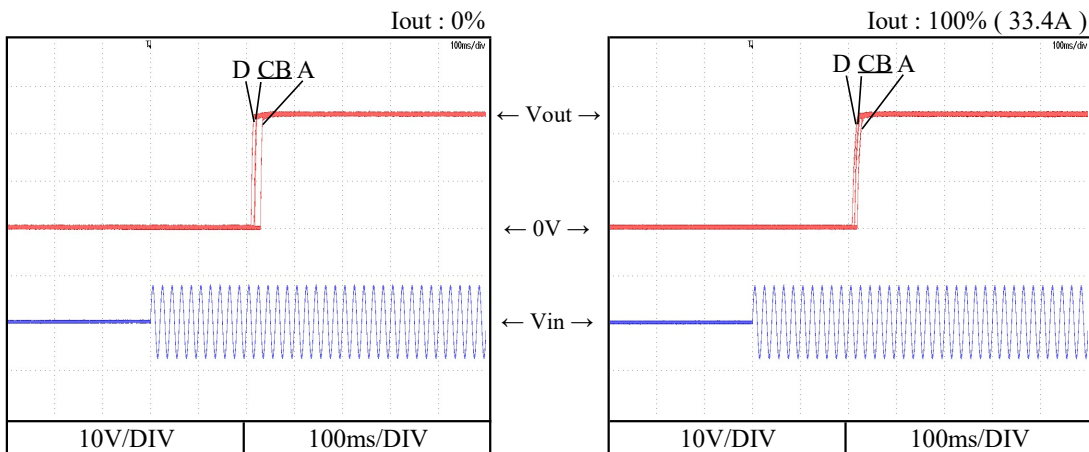

2-4. Output rise characteristics

Conditions Vin : 85 VAC (A)
 115 VAC (B)
 230 VAC (C)
 265 VAC (D)
 Istb : 100 %
 Ta : 25 °C

36V

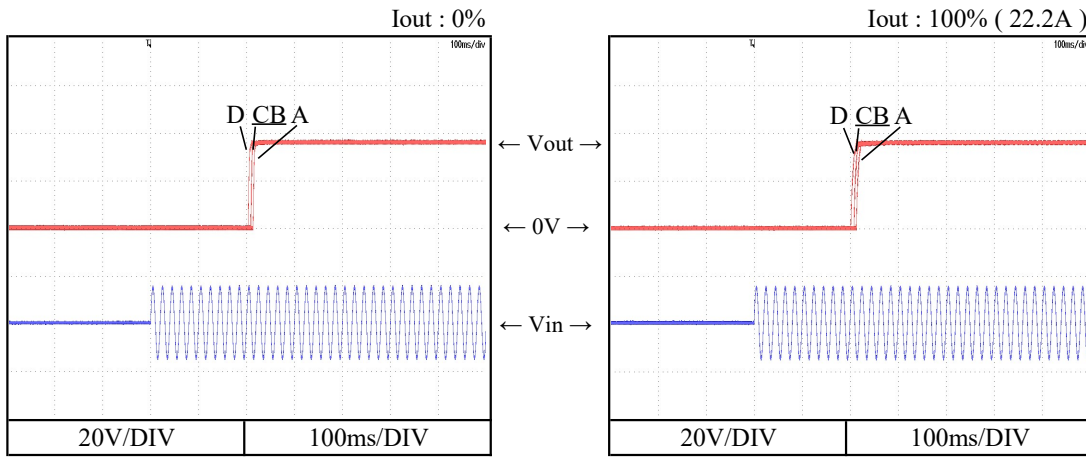

48V

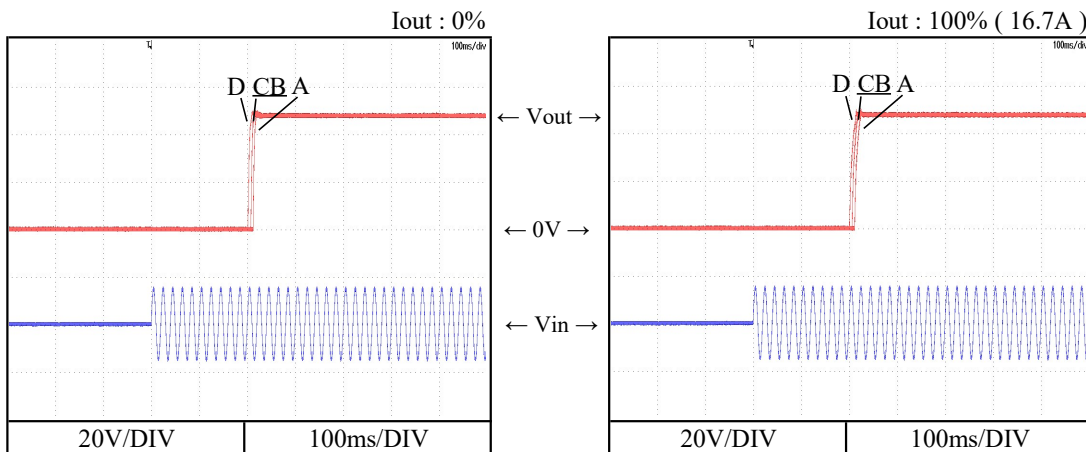

2-5. Output fall characteristics

Conditions Vin : 85 VAC (A)
 115 VAC (B)
 230 VAC (C)
 265 VAC (D)
 Istb : 100 %
 Ta : 25 °C

12V

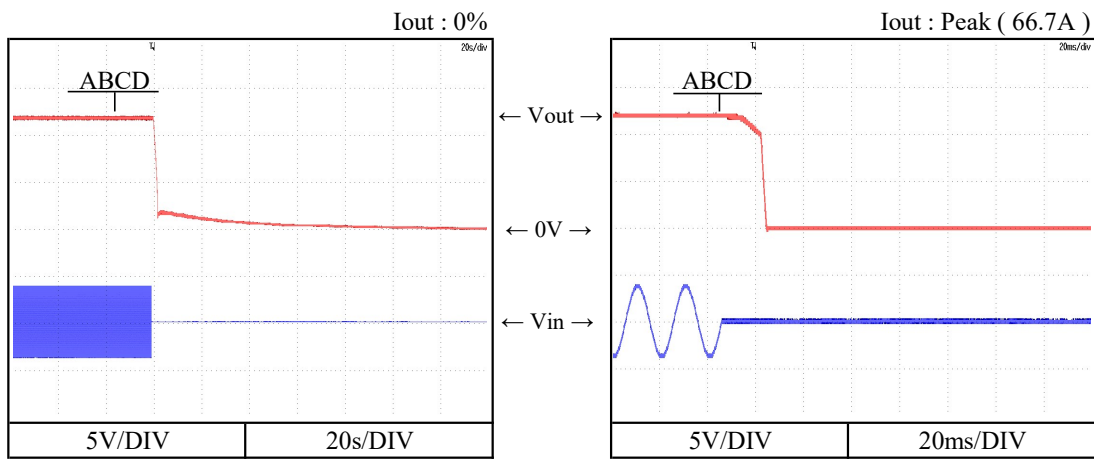

24V

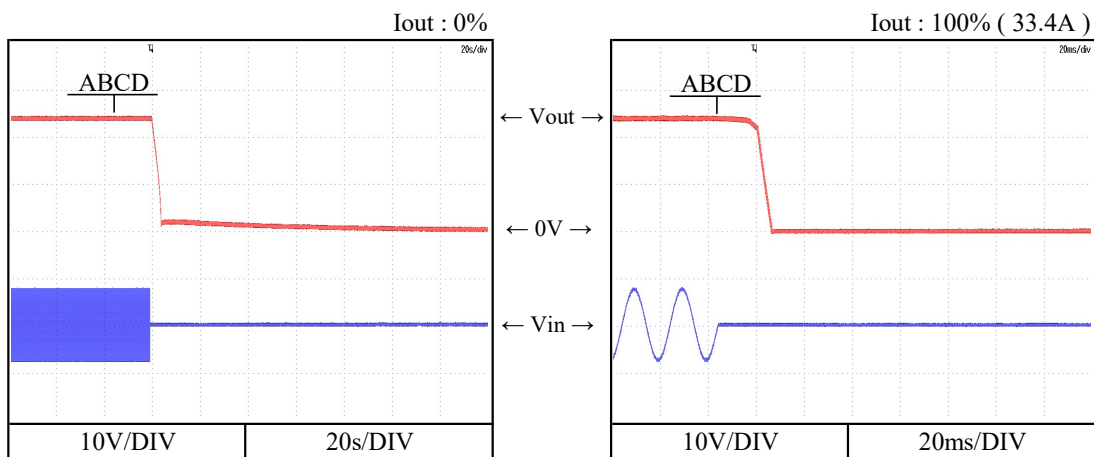

2-5. Output fall characteristics

Conditions Vin : 85 VAC (A)
 115 VAC (B)
 230 VAC (C)
 265 VAC (D)
 Istb : 100 %
 Ta : 25 °C

36V

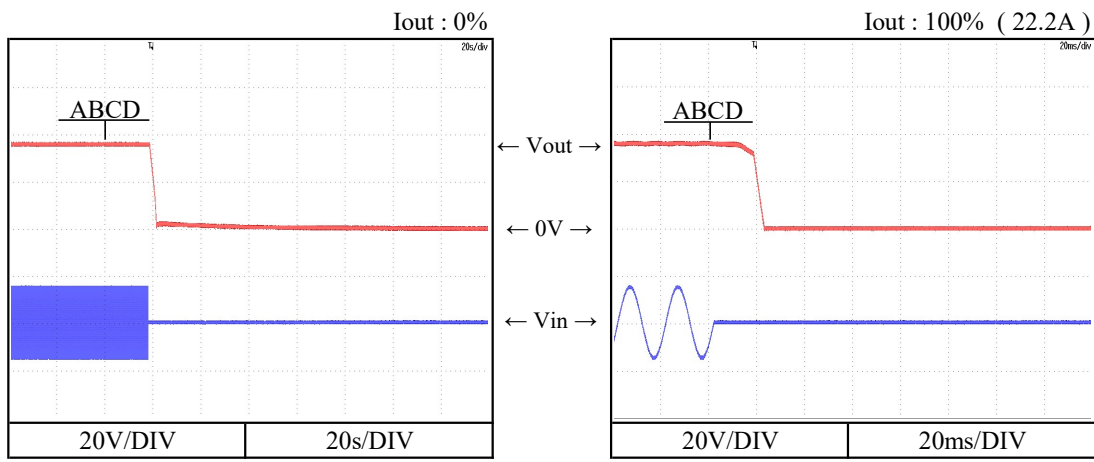

48V

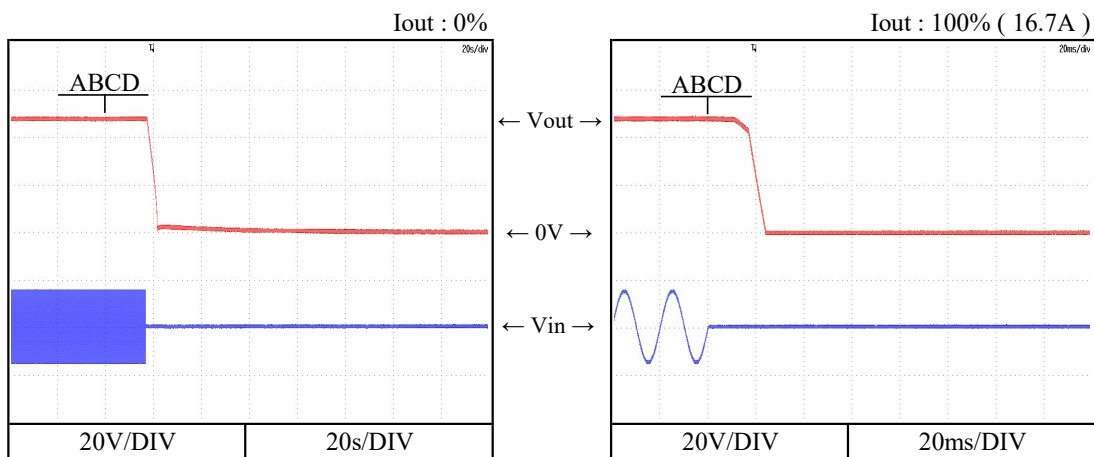

2-6. Various signal

Conditions Vin : 115 VAC
 Iout : 100 %
 Istb : 100 %
 Ta : 25 °C

Output rise, fall characteristics with Remote ON/OFF Control

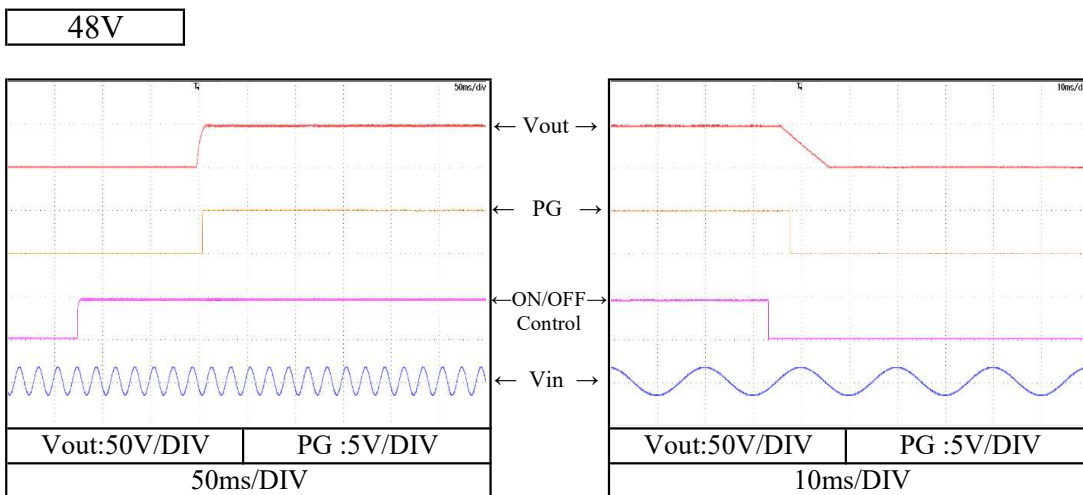

Output rise, fall characteristics with Input voltage ON/OFF

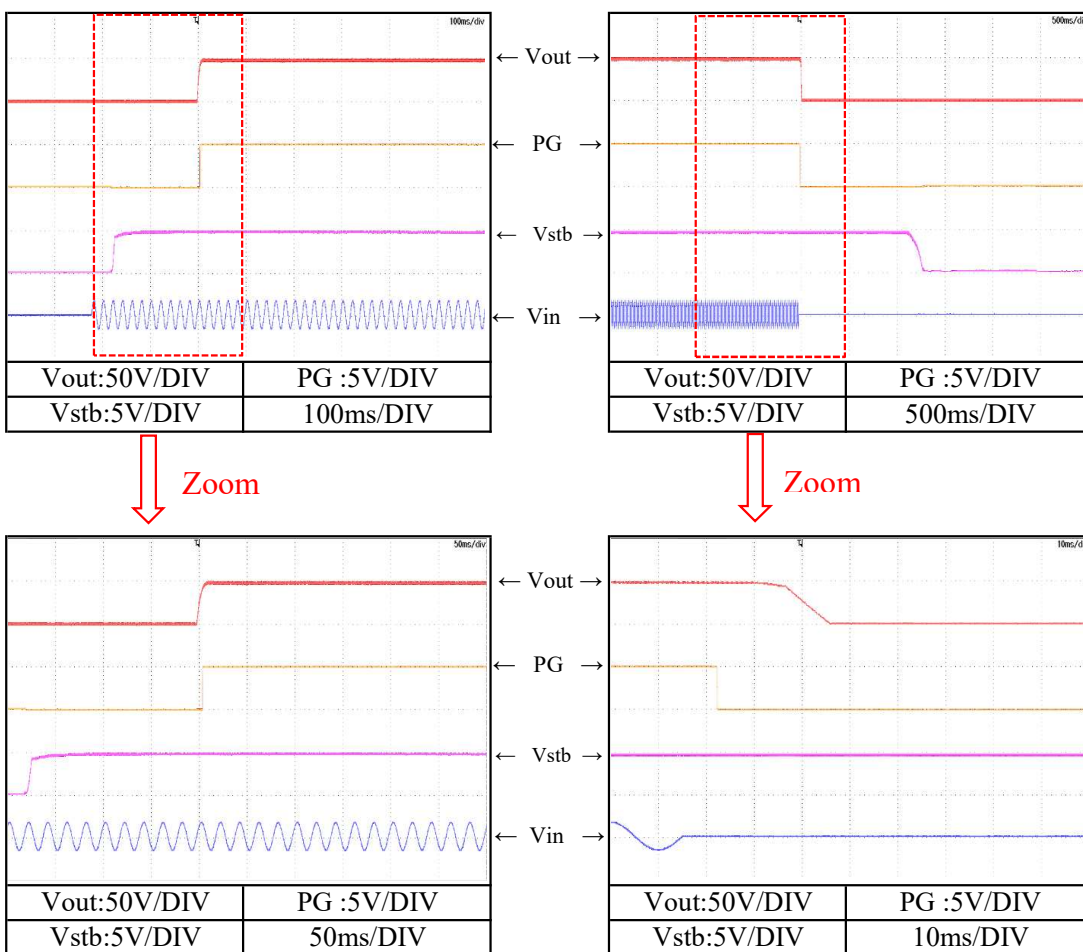

2-7. Over current protection (OCP) characteristics

Conditions V_{in} : 115 VAC
 I_{stb} : 100 %
 T_a : 25 °C

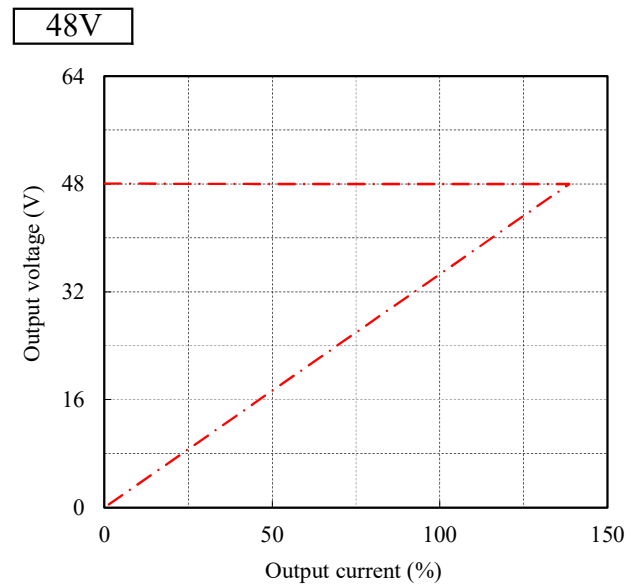
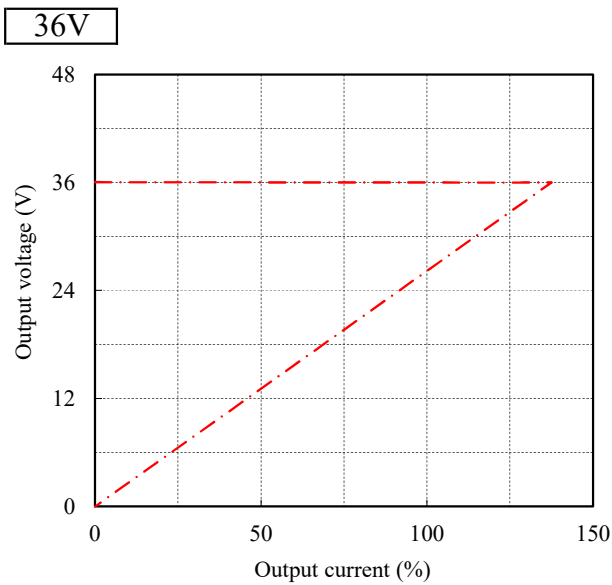
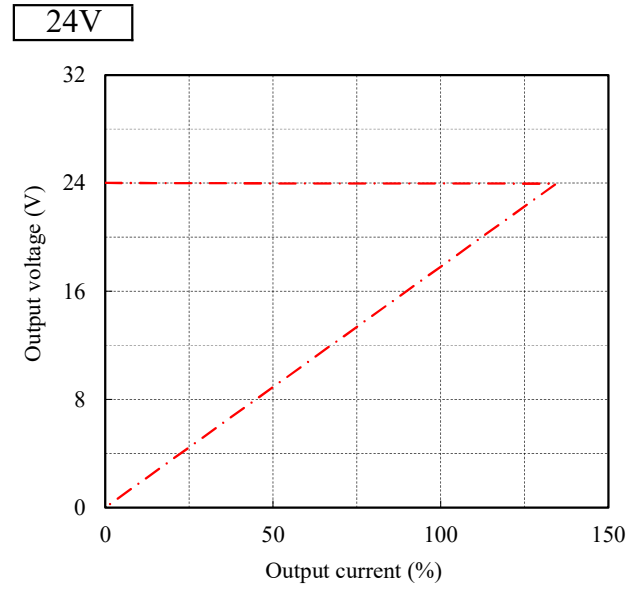
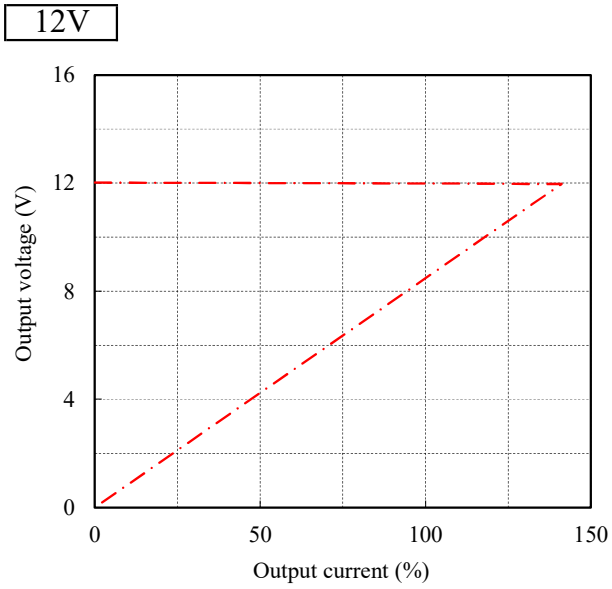

2-8. Over voltage protection (OVP) characteristics

Conditions Vin : 115 VAC

Iout : 0 %

Istb : 0 %

Ta : 25 °C

12V

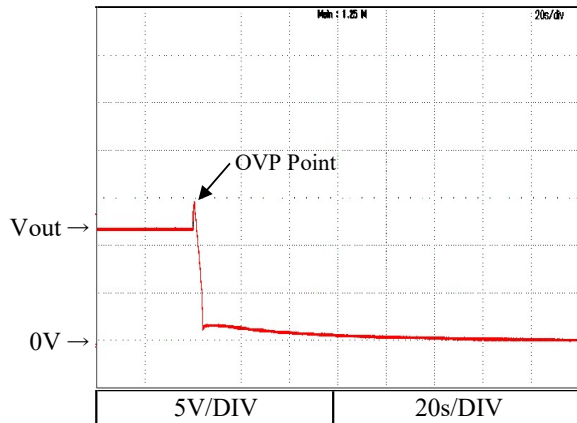

24V

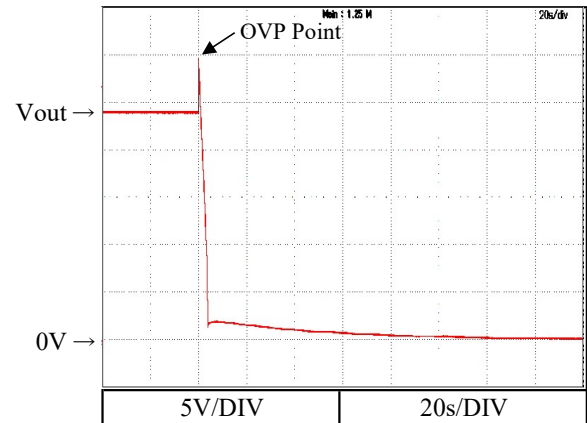

36V

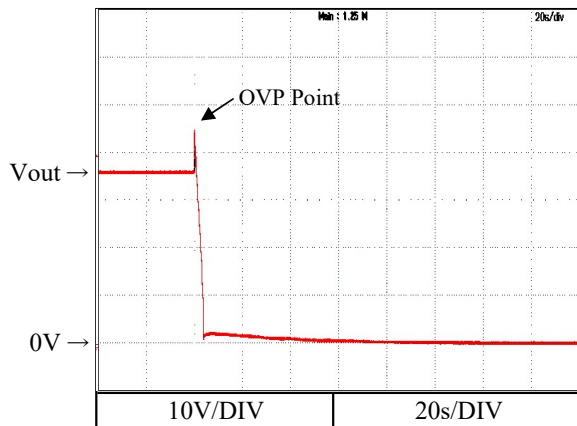

48V

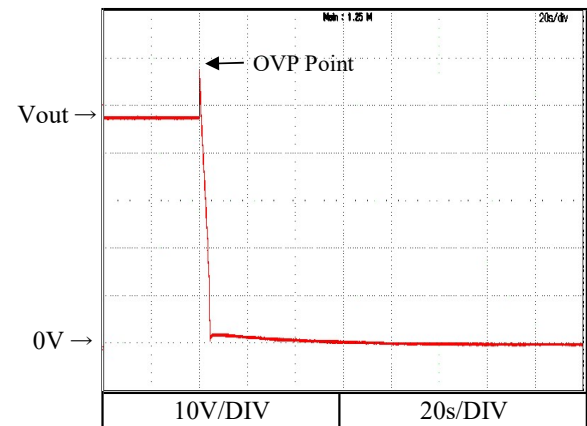

2-9. Dynamic load response characteristics

Conditions V_{in} : 115 VAC
 I_{out} : 50 % \leftrightarrow 100 % (Peak)
 ($t_r = t_f = 50\mu s$)
 I_{stb} : 100 %
 T_a : 25 °C

12V

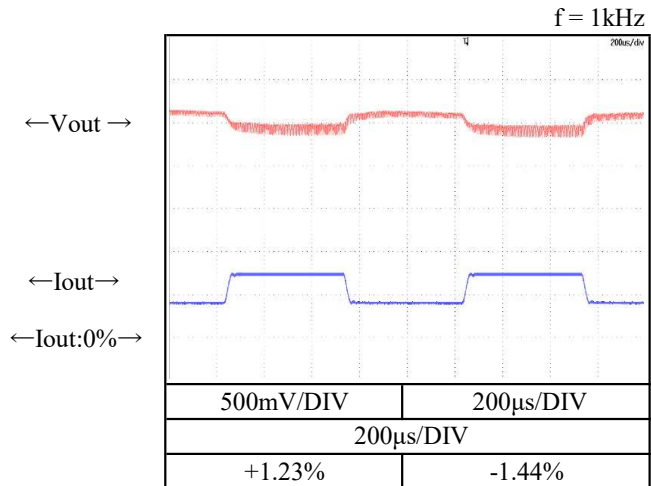
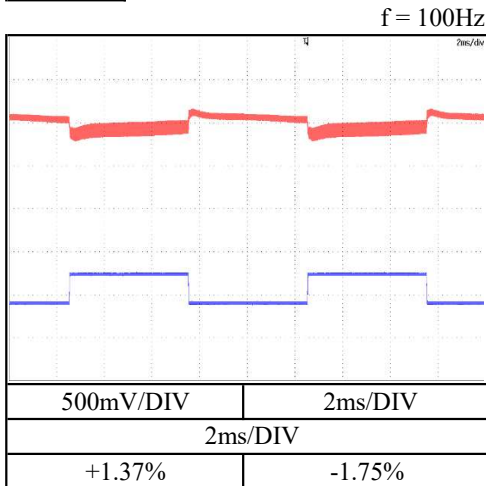

24V

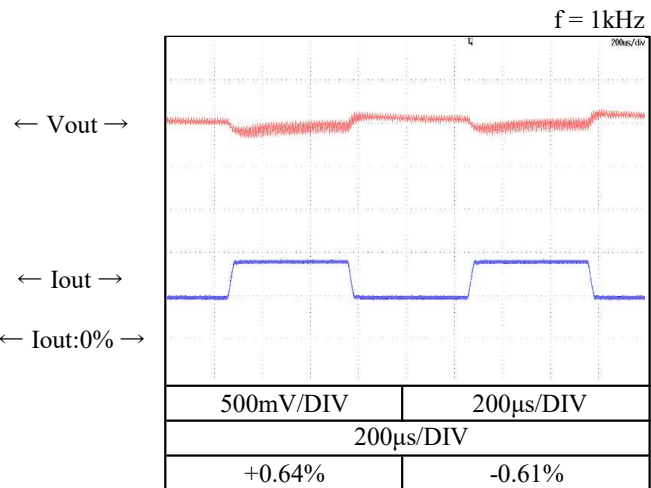
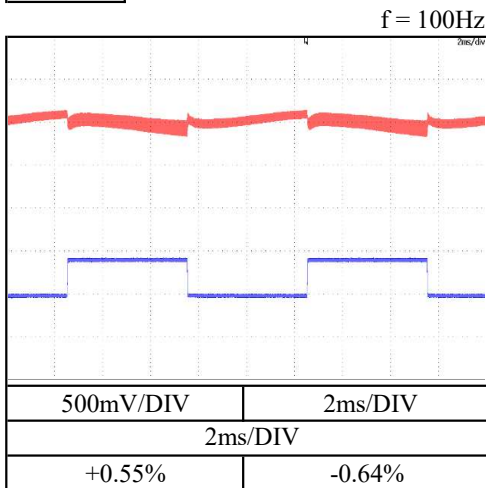

2-9. Dynamic load response characteristics

Conditions Vin : 115 VAC
 Iout : 50 % ↔ 100 % (Peak)
 (tr = tf = 50us)
 Istb : 100 %
 Ta : 25 °C

36V

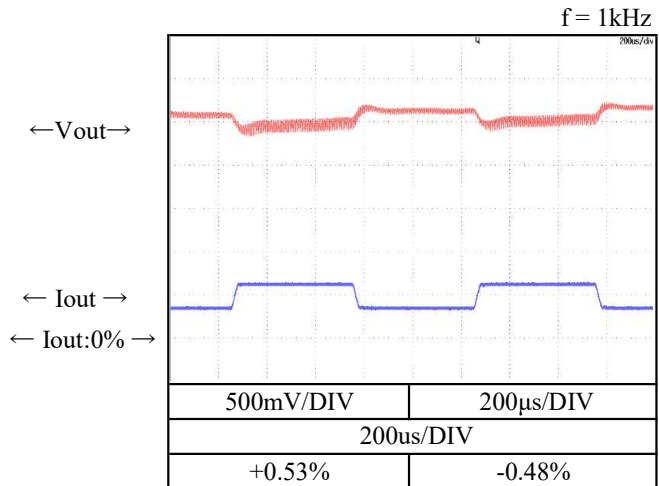
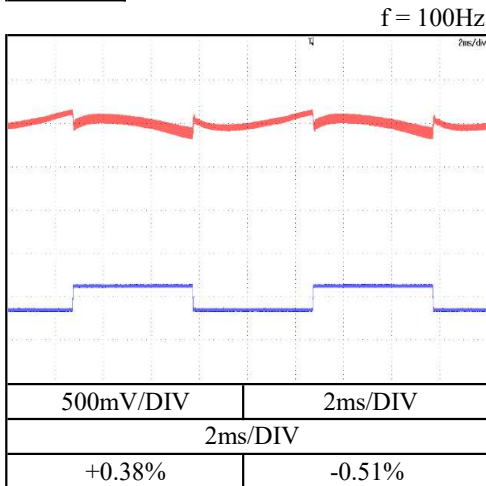

48V

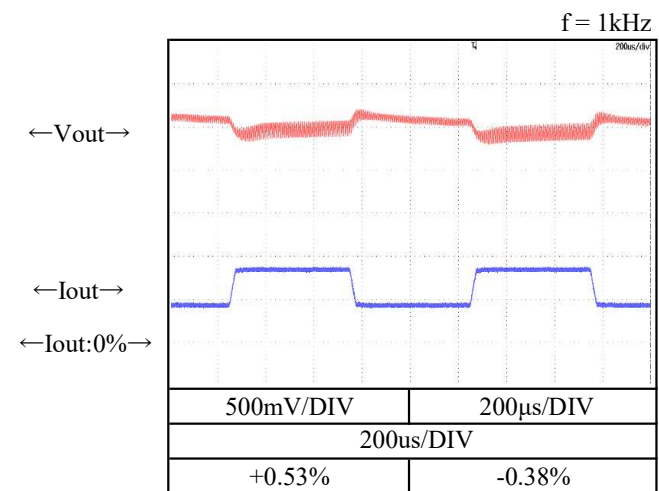
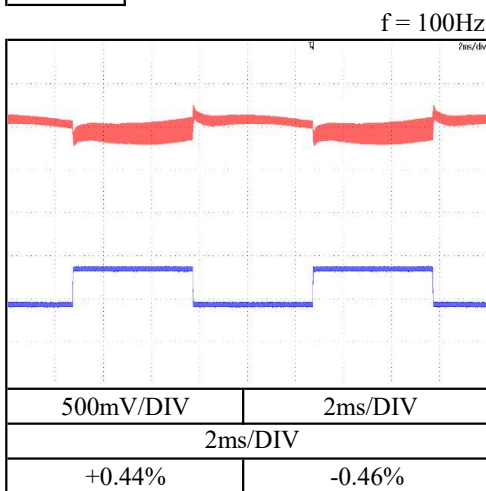

2-10. Response to brown out characteristics

Conditions Iout : 100 %
 Istb : 100 %
 Ta : 25 °C

Interruption time

- A : Output voltage does not drop.
- B : Output voltage drop down to 20~40% of the nominal output voltage.
- C : Output voltage drops until 0V.

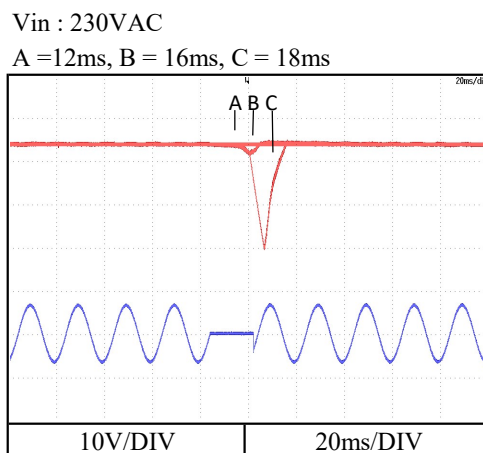
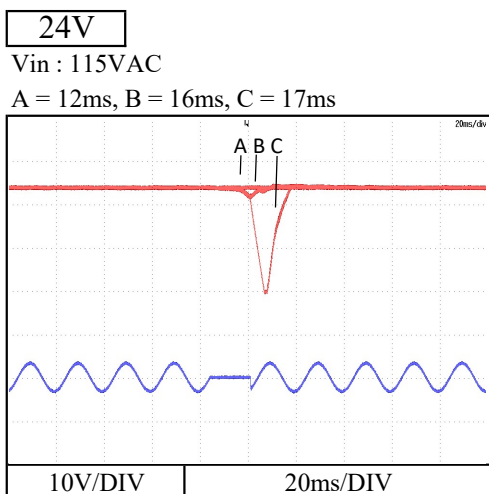
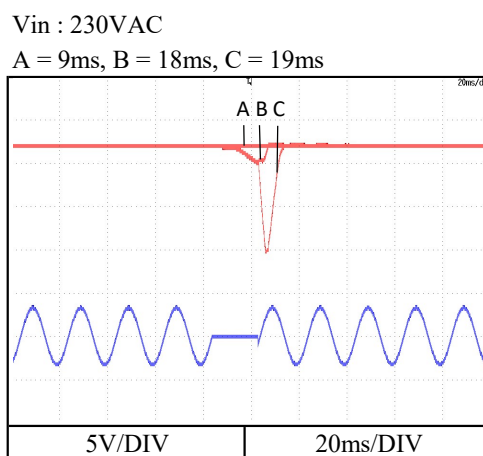
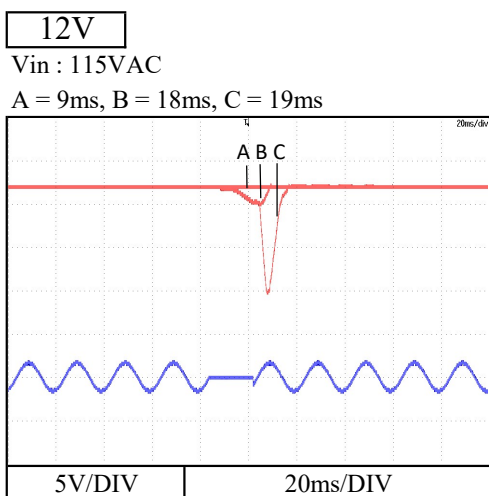

2-10. Response to brown out characteristics

Conditions Iout : 100 %
 Istb : 100 %
 Ta : 25 °C

Interruption time

- A : Output voltage does not drop.
- B : Output voltage drop down to 20~40% of the nominal output voltage.
- C : Output voltage drops until 0V.

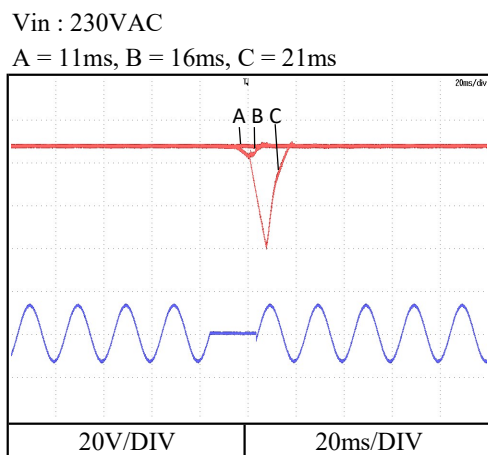
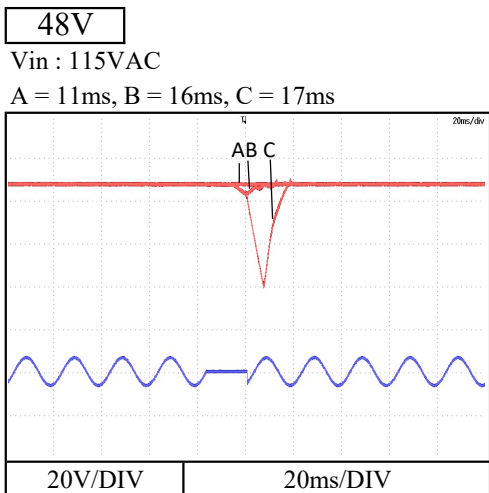
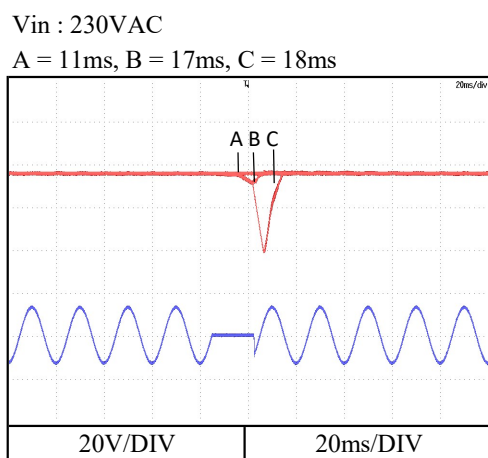
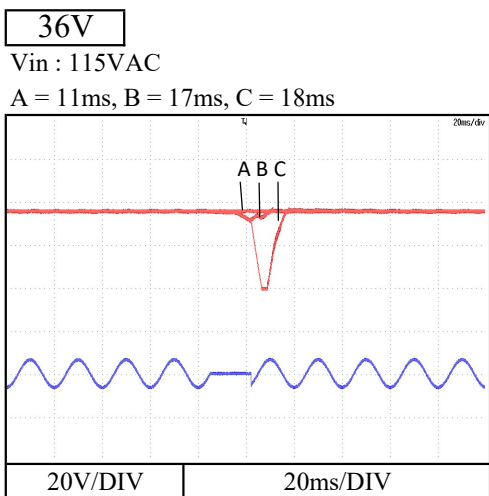

2-11. Inrush current waveform

Conditions Vin : 115 VAC
 Iout : 100 % (16.7A)
 Istb : 100 %
 Ta : 25 °C

48V

Switch on phase angle of input AC voltage
 $\phi = 0^\circ$

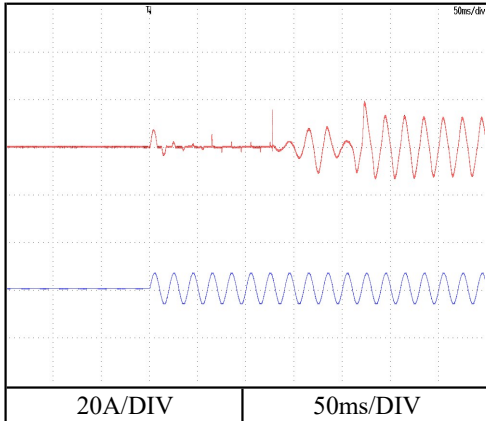

← Iin →

← Vin →

Switch on phase angle of input AC voltage
 $\phi = 90^\circ$

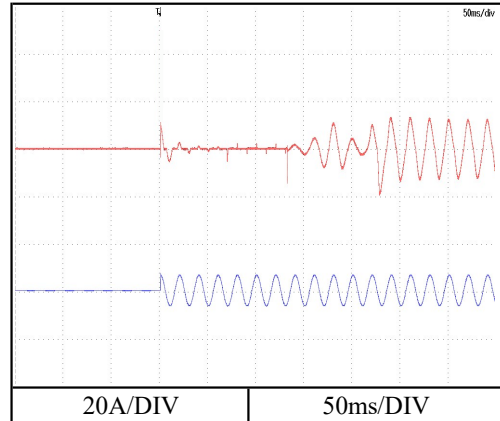

Conditions Vin : 230 VAC
 Iout : 100 % (16.7A)
 Istb : 100 %
 Ta : 25 °C

Switch on phase angle of input AC voltage
 $\phi = 0^\circ$

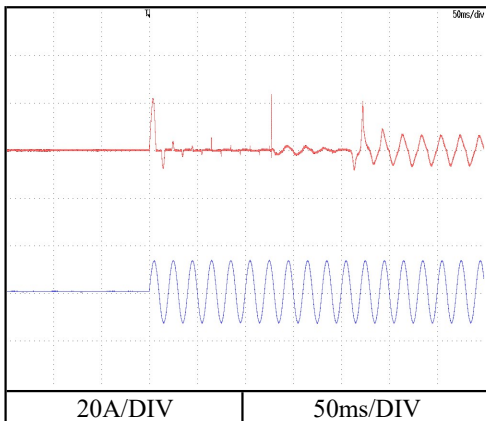

← Iin →

← Vin →

Switch on phase angle of input AC voltage
 $\phi = 90^\circ$

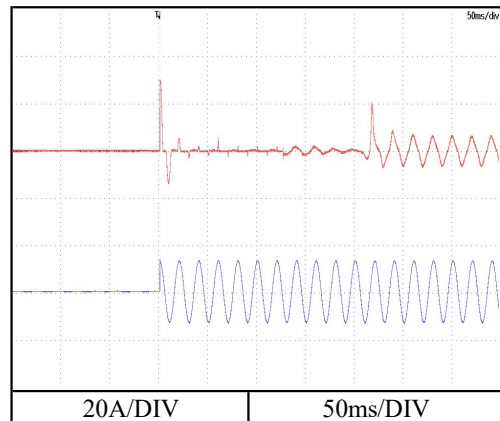

2-12. Input current harmonics

Conditions Vin : 100 VAC
 Iout : 16.7 A (100%)
 Istb : 100 %
 Ta : 25 °C

48V

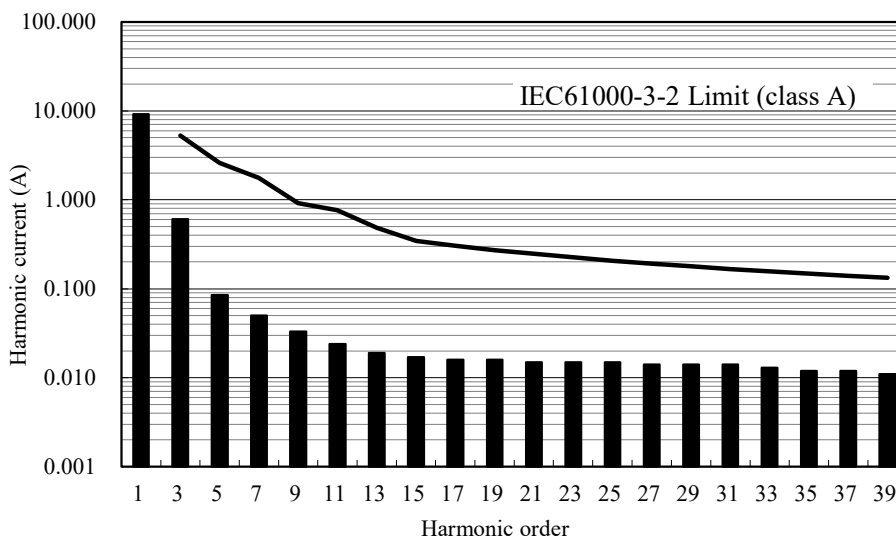

Conditions Vin : 230 VAC
 Iout : 16.7 A (100%)
 Istb : 100 %
 Ta : 25 °C

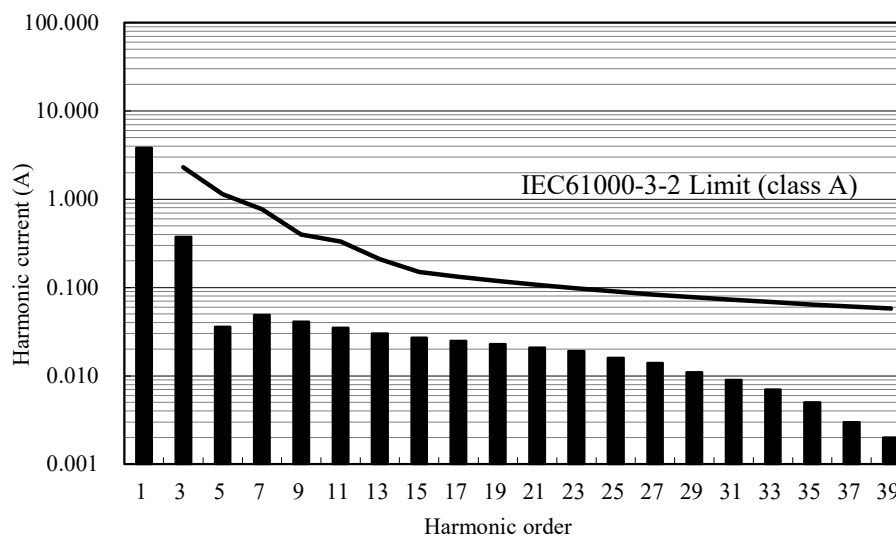

2-13. Leakage current characteristics

Earth leakage current of CLASS I equipment

Conditions Iout : 0 % ———
 100 % - - - -
 Ta : 25 °C
 Istb : 100 %
 f : 60 Hz

48V

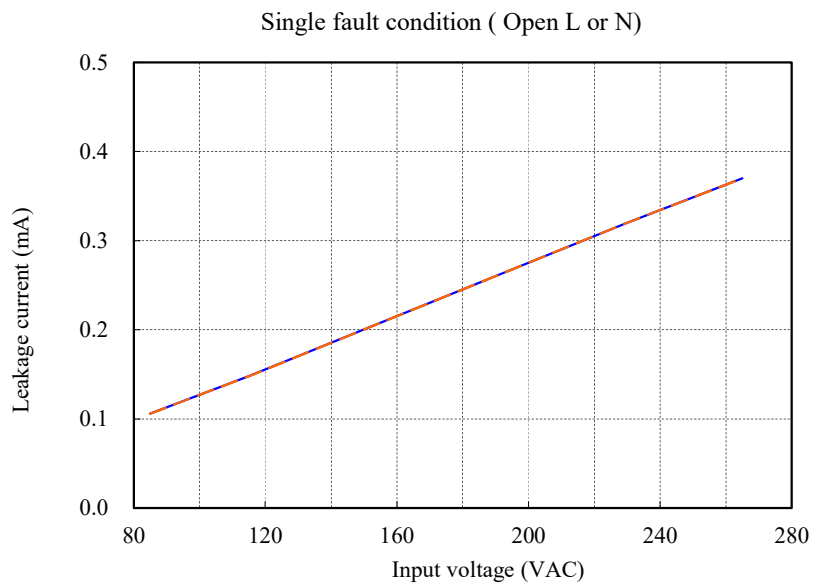
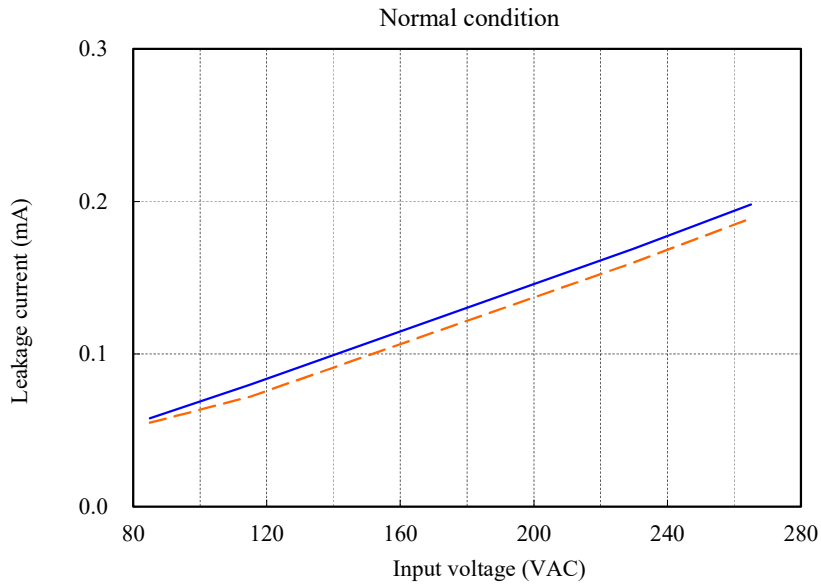

2-13. Leakage current characteristics

Patient leakage current of CLASS I equipment

Conditions Iout : 0 % ———
 100 % - - - -
 Ta : 25 °C
 Istb : 100 %
 f : 60 Hz

48V

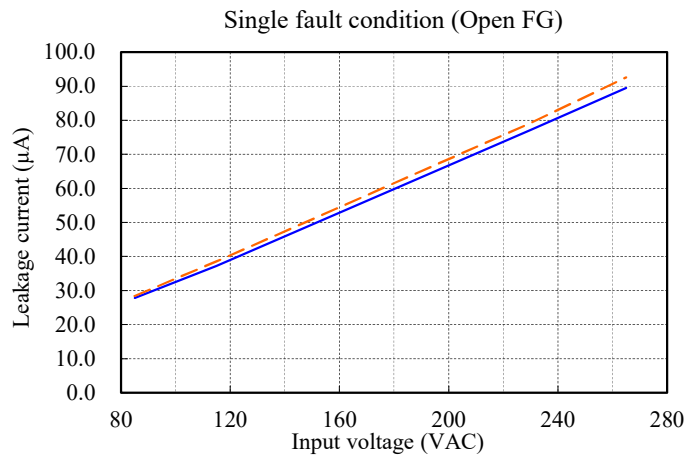
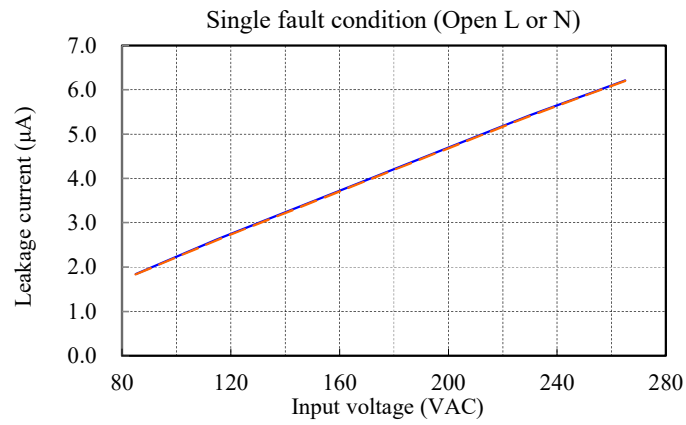
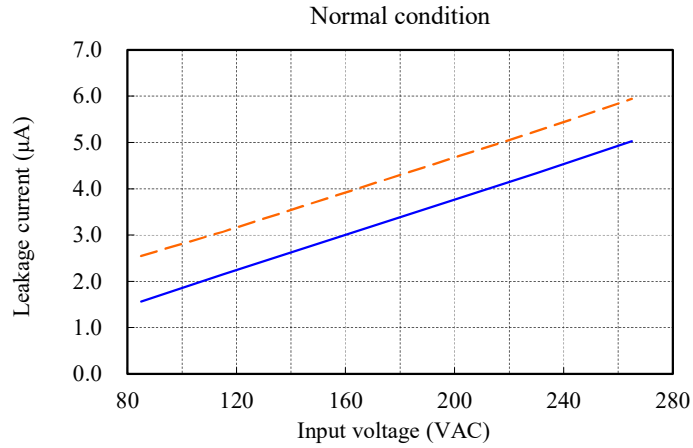

2-14. Output ripple and noise waveform

Conditions Vin : 115 VAC
 Istb : 100 %
 Ta : 25 °C
 Iout : 100 %

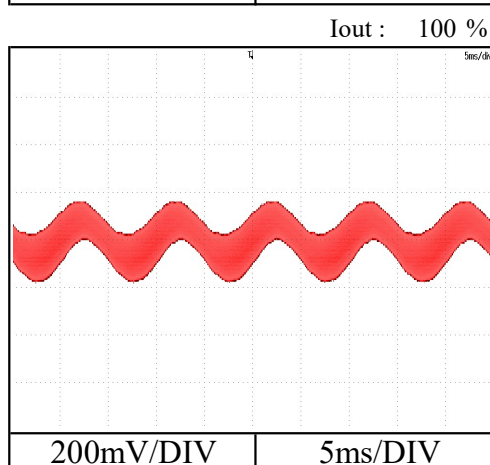
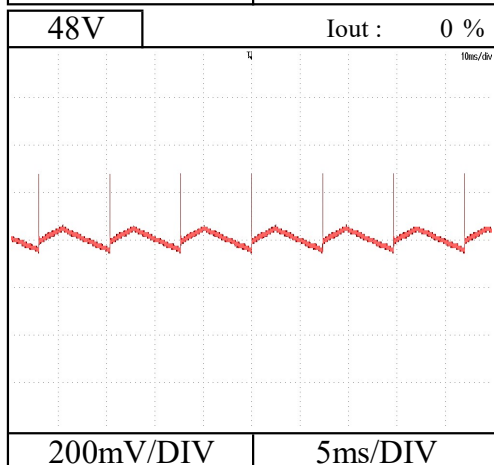
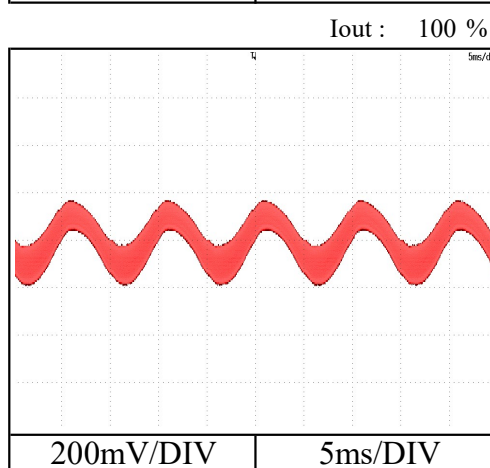
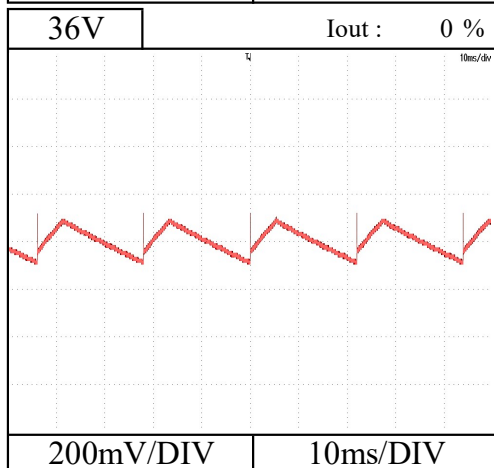
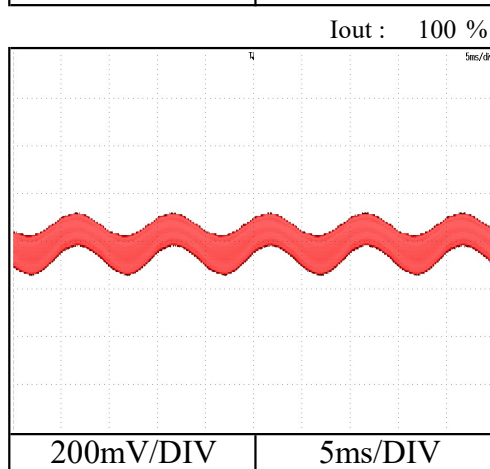
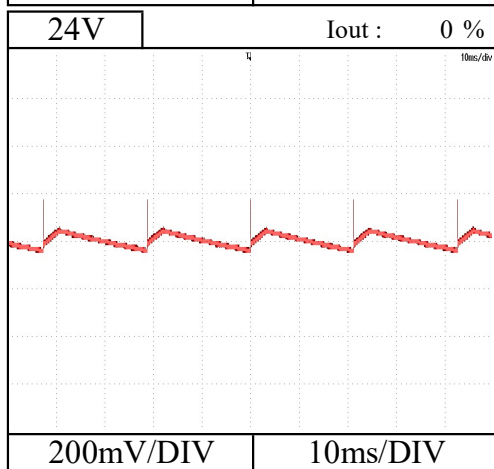
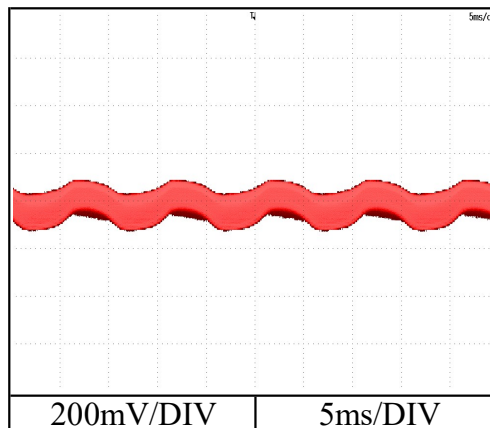
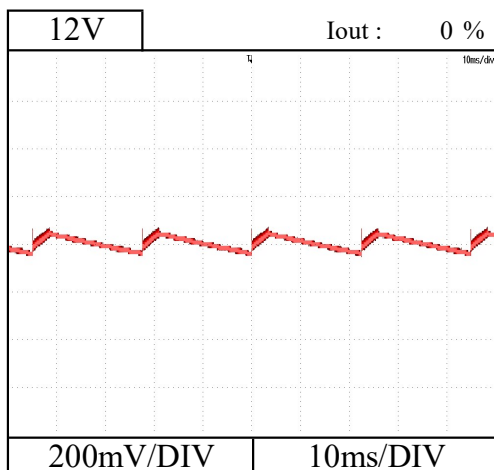

2-15. Electro-Magnetic Interference characteristics

Conditions Vin : 115 VAC
 Iout : 56.7 A (100%)
 Istb : 100 %
 Ta : 25 °C

Conducted Emission

12V

Ref. Data	Point A (150kHz)	
	Limit (dB)	Measure (dB)
QP	66.0	57.9
AV	56.0	48.7

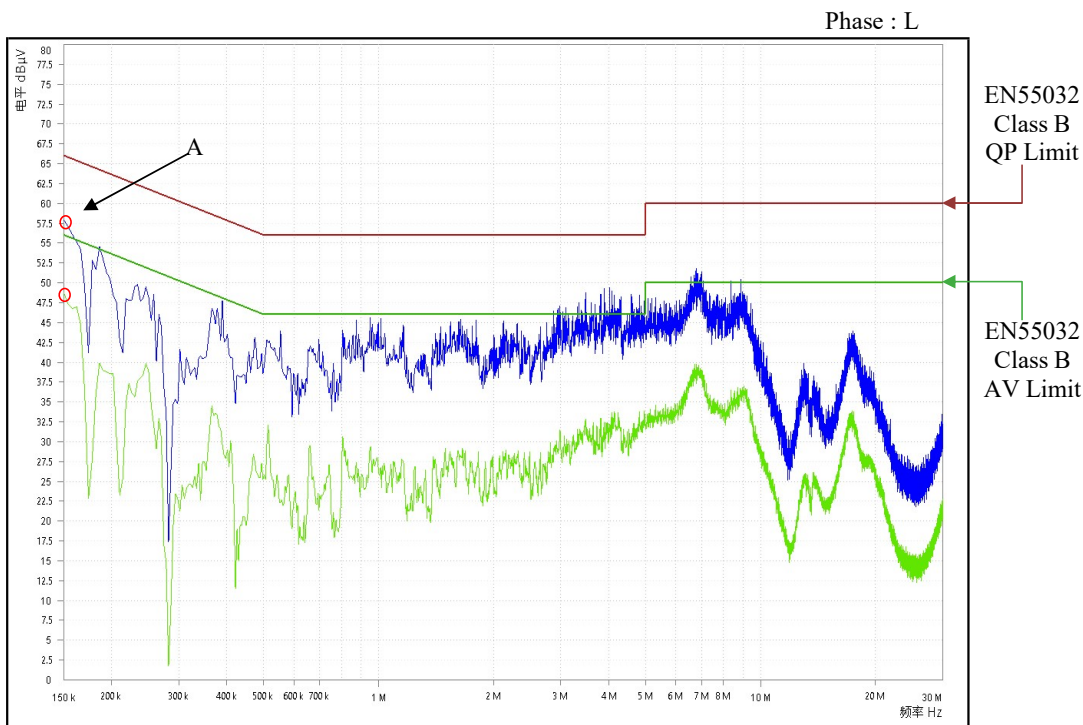

Ref. Data	Point B (150kHz)	
	Limit (dB)	Measure (dB)
QP	66.0	58.0
AV	56.0	48.4

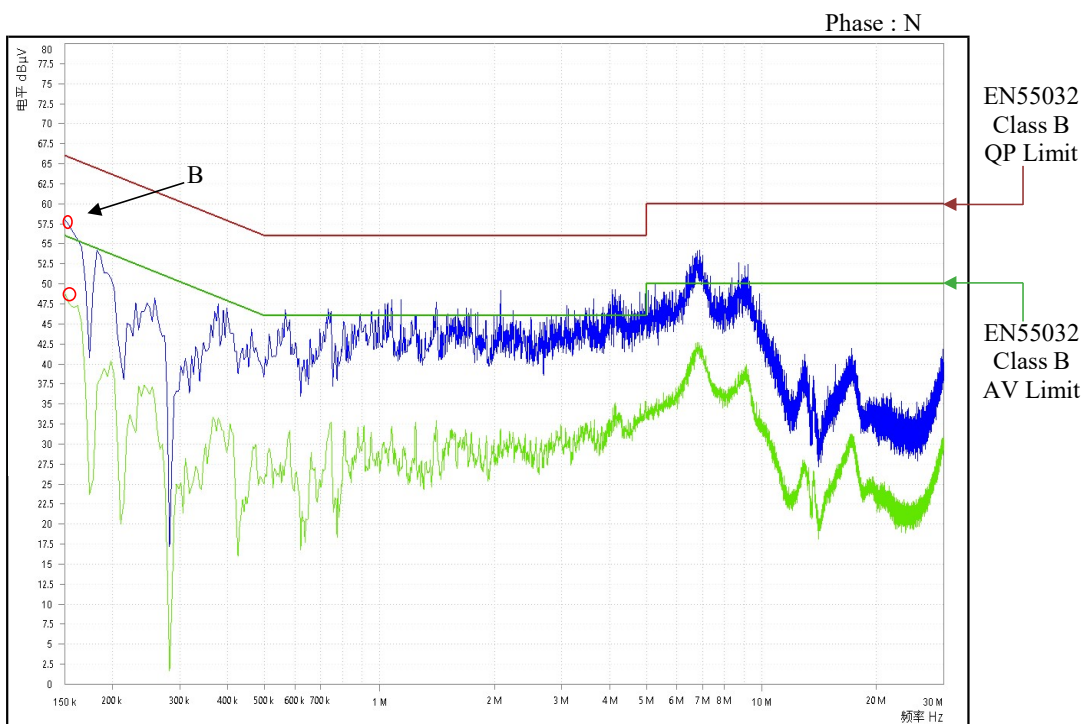

Limit of EN55011-B,FCC-Class B are same as its EN55032-B.

2-15. Electro-Magnetic Interference characteristics

Conditions Vin : 230 VAC
 Iout : 56.7 A (100%)
 Istb : 100 %
 Ta : 25 °C

Conducted Emission

12V

Ref. Data	Point A (154kHz)	
	Limit (dB)	Measure (dB)
QP	65.8	60.2
AV	56.0	48.3

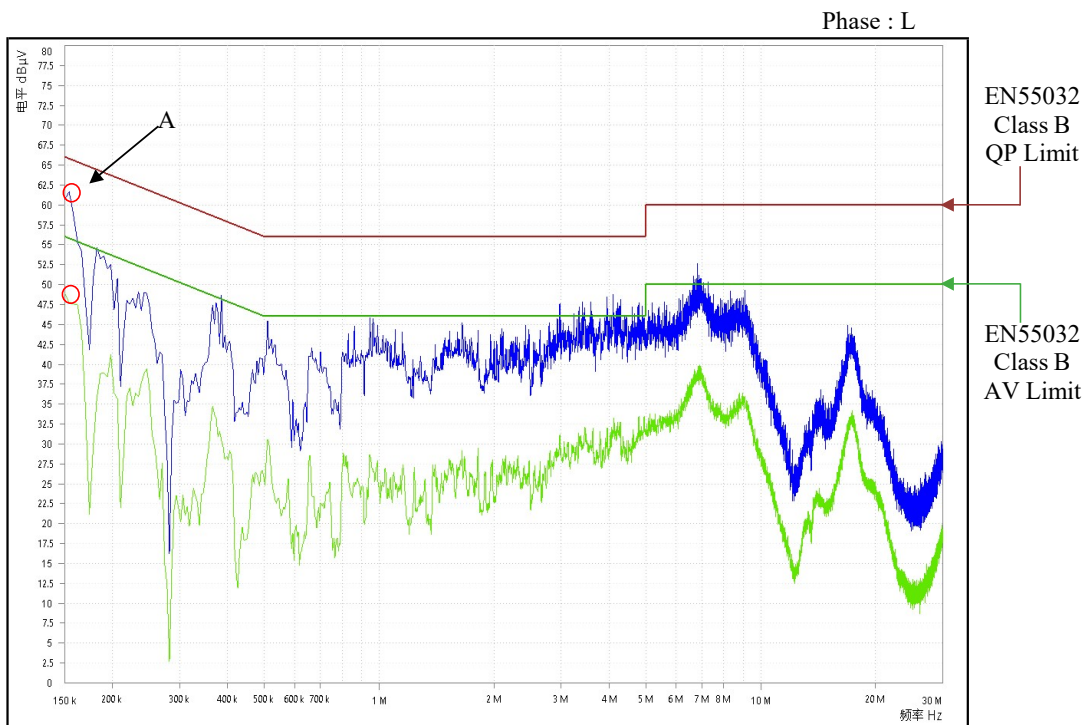

Ref. Data	Point B (154kHz)	
	Limit (dB)	Measure (dB)
QP	65.8	60.4
AV	56.0	48.5



Limit of EN55011-B,FCC-Class B are same as its EN55032-B.

2-15. Electro-Magnetic Interference characteristics

Conditions Vin : 115 VAC
 Iout : 33.4 A (100%)
 Istb : 100 %
 Ta : 25 °C

Conducted Emission

24V

Point A (3.934MHz)		
Ref. Data	Limit (dB)	Measure (dB)
QP	56.0	48.1
AV	46.0	36.3

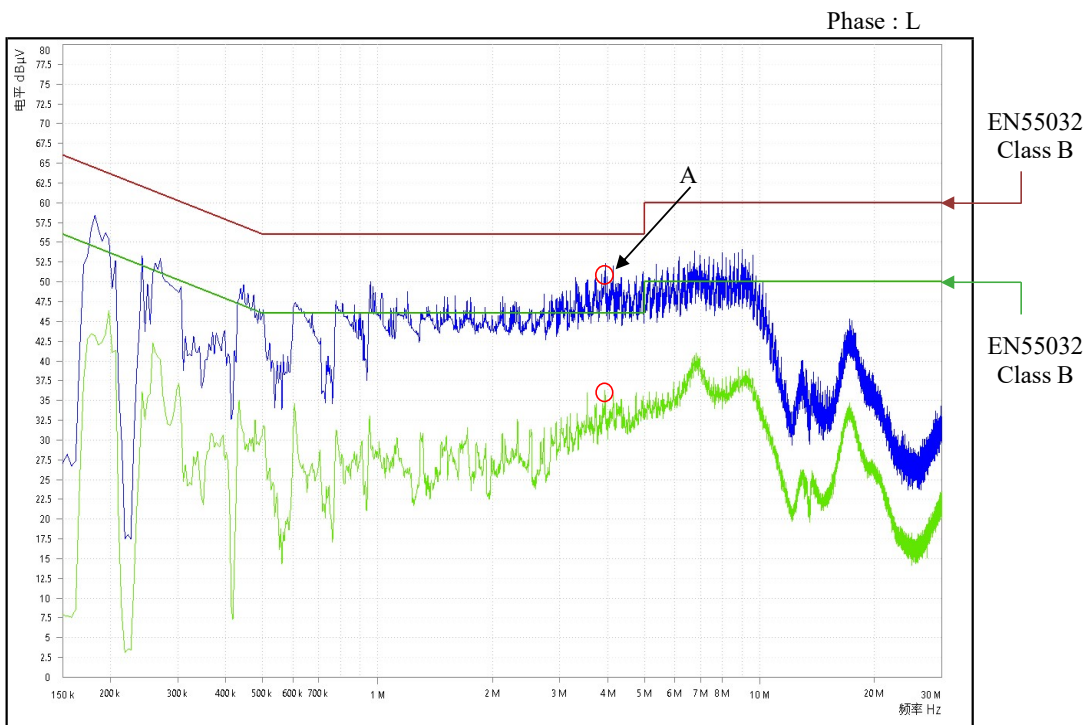

Point B (6.966MHz)		
Ref. Data	Limit (dB)	Measure (dB)
QP	60.0	51.8
AV	50.0	42.4

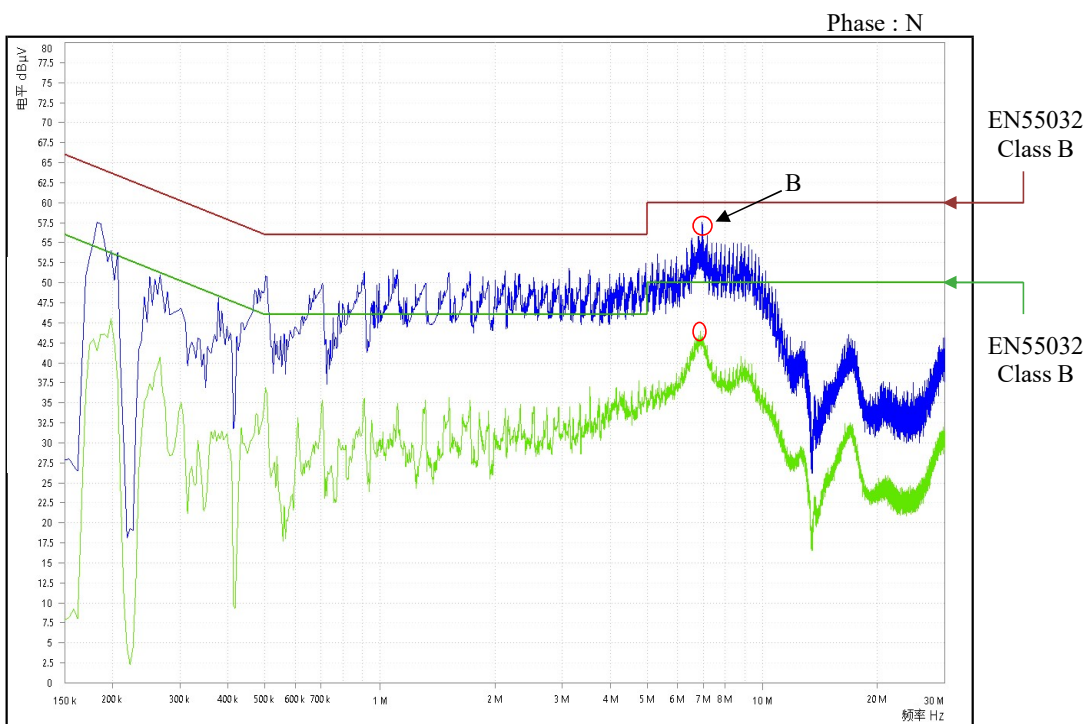

Limit of EN55011-B,FCC-Class B are same as its EN55032-B.

2-15. Electro-Magnetic Interference characteristics

Conditions Vin : 230 VAC
 Iout : 33.4 A (100%)
 Istb : 100 %
 Ta : 25 °C

Conducted Emission

24V

Ref. Data	Point A (4.93MHz)	
	Limit (dB)	Measure (dB)
QP	56.0	48.2
AV	46.0	35.5

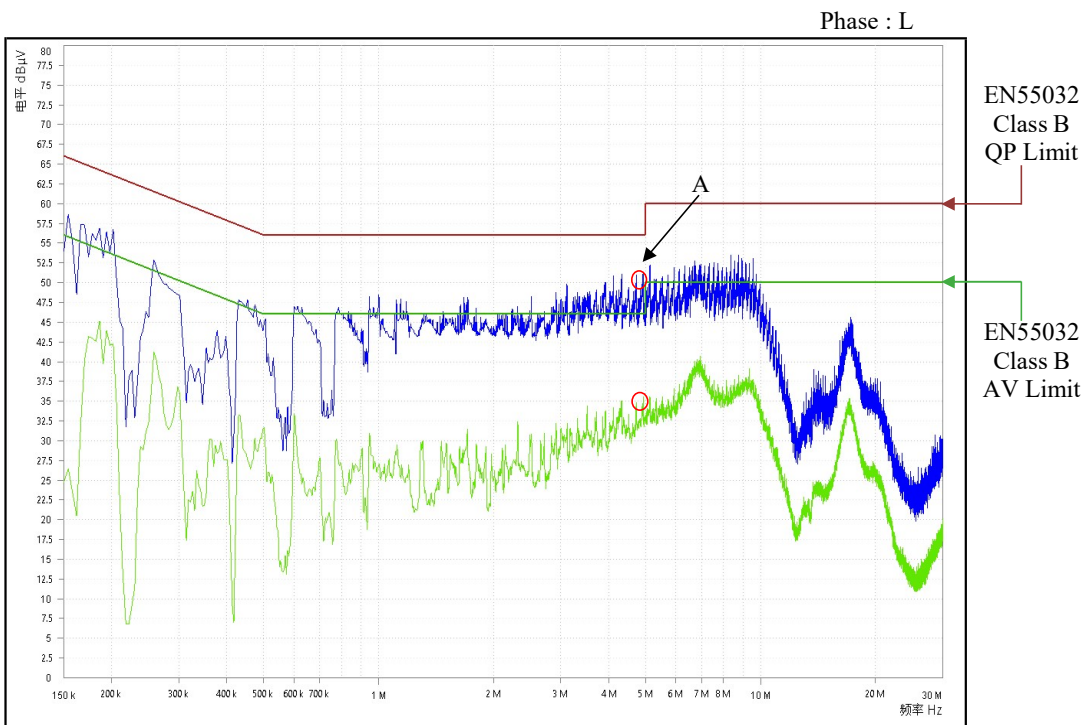

Ref. Data	Point B (6.962MHz)	
	Limit (dB)	Measure (dB)
QP	60.0	52.5
AV	50.0	42.5

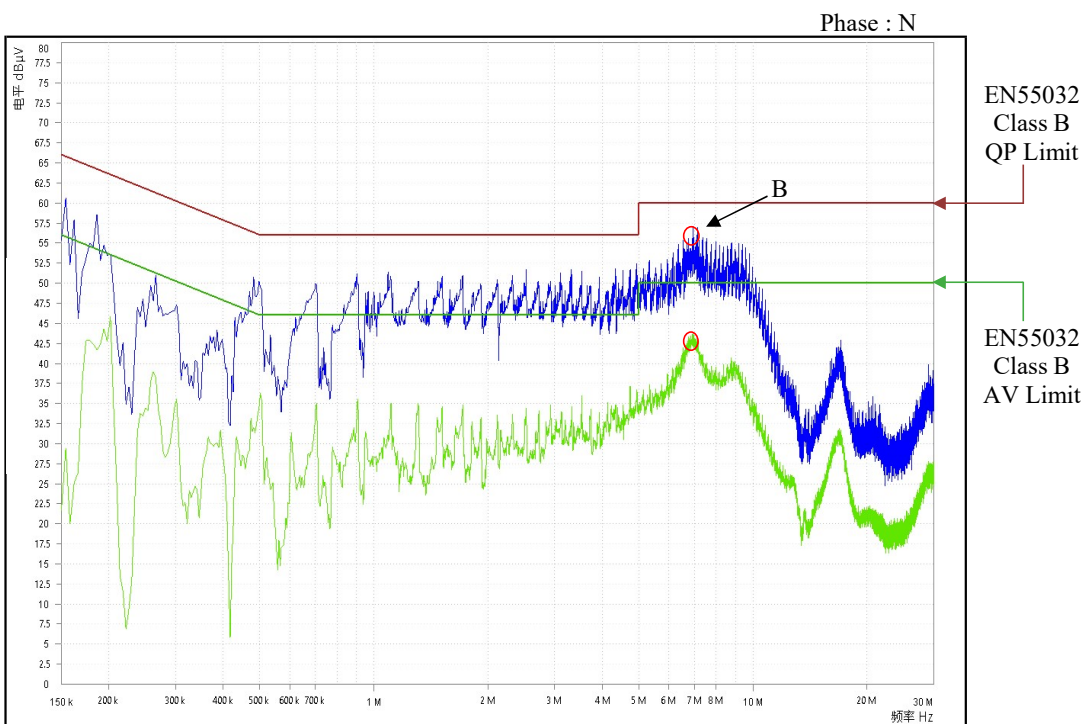

Limit of EN55011-B,FCC-Class B are same as its EN55032-B.

2-15. Electro-Magnetic Interference characteristics

Conditions Vin : 115 VAC
 Iout : 22.2 A (100%)
 Istb : 100 %
 Ta : 25 °C

Conducted Emission

36V

Ref. Data	Point A (3.902MHz)	
	Limit (dB)	Measure (dB)
QP	56.0	47.1
AV	46.0	35.1

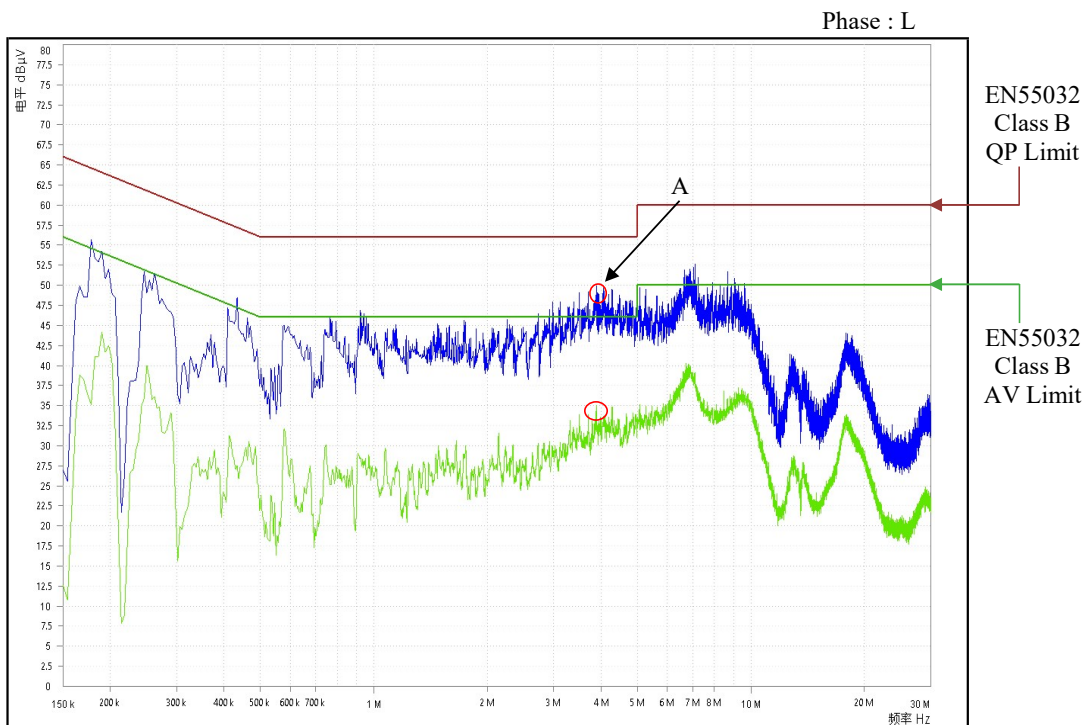

Ref. Data	Point B (6.922MHz)	
	Limit (dB)	Measure (dB)
QP	60.0	50.1
AV	50.0	42.7

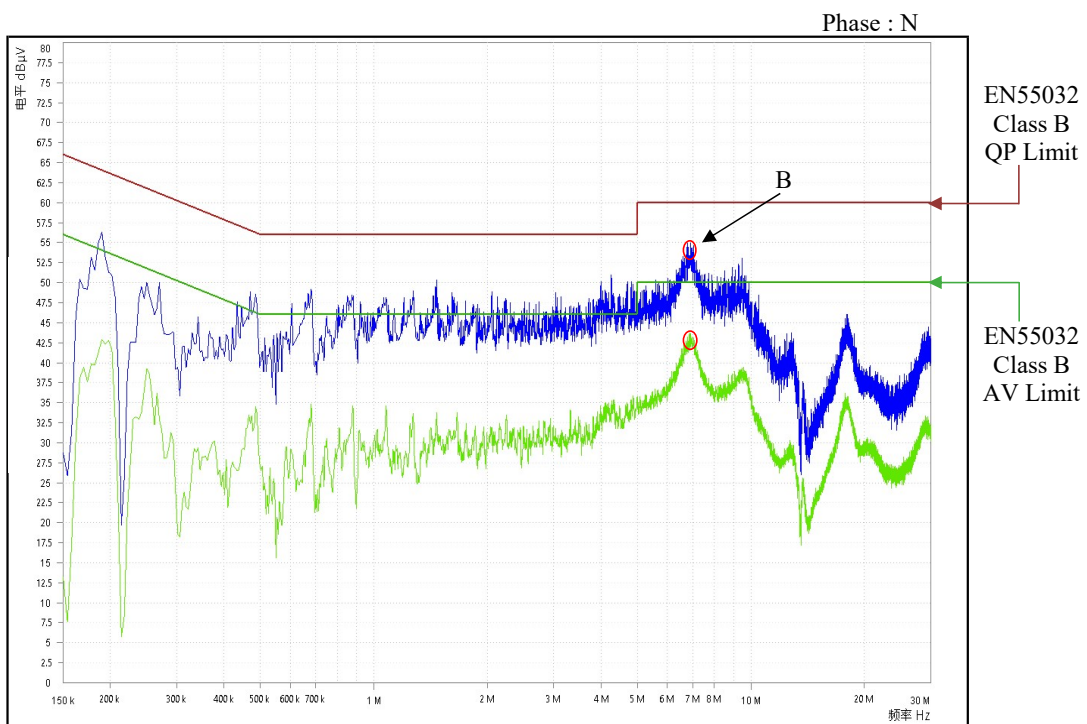

Limit of EN55011-B,FCC-Class B are same as its EN55032-B.

2-15. Electro-Magnetic Interference characteristics

Conditions Vin : 230 VAC
 Iout : 22.2 A (100%)
 Istb : 100 %
 Ta : 25 °C

Conducted Emission

36V

Ref. Data	Point A (6.894MHz)	
	Limit (dB)	Measure (dB)
QP	60.0	51.0
AV	50.0	40.2

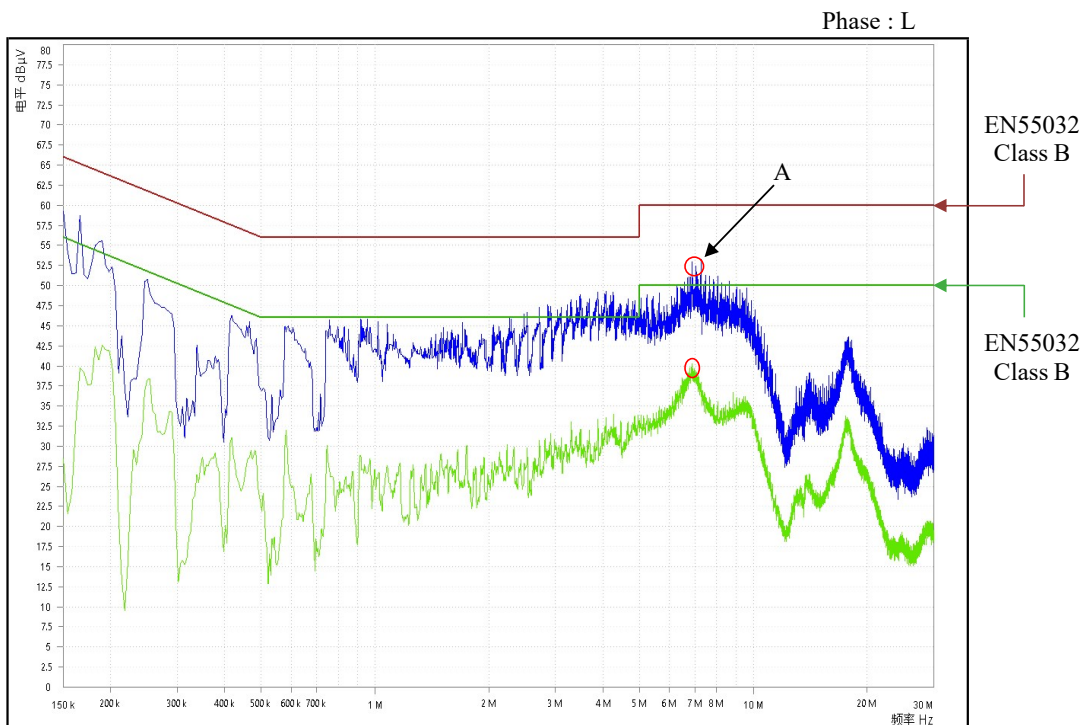

Ref. Data	Point B (6.982MHz)	
	Limit (dB)	Measure (dB)
QP	60.0	51.6
AV	50.0	42.7

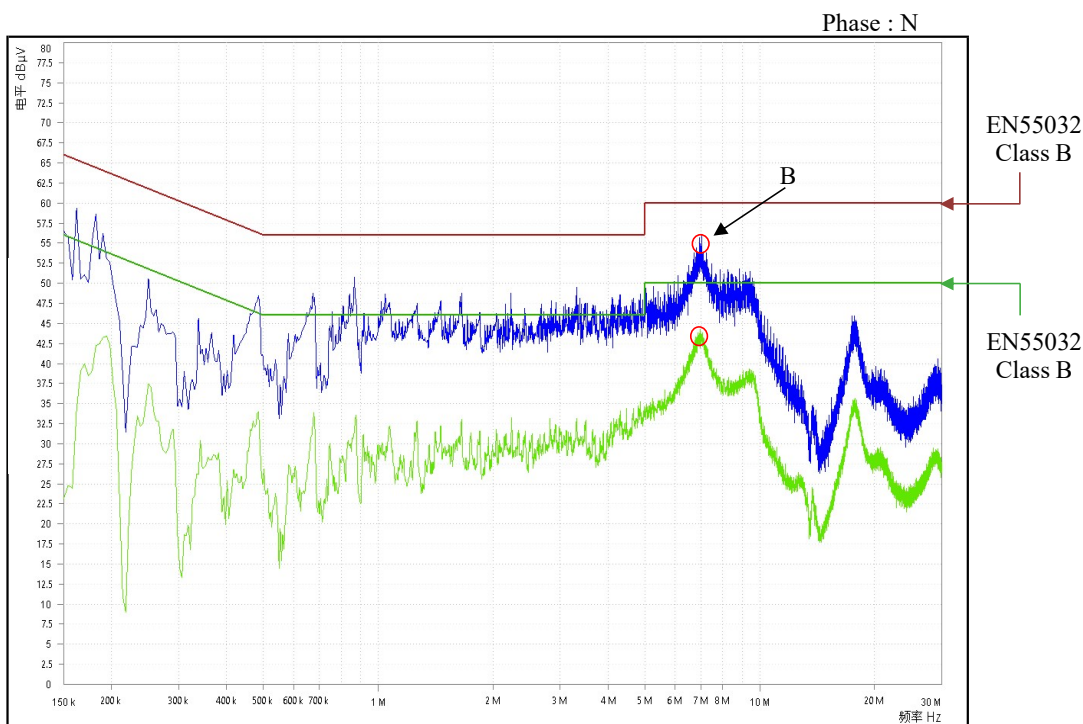

Limit of EN55011-B,FCC-Class B are same as its EN55032-B.

2-15. Electro-Magnetic Interference characteristics

Conditions Vin : 115 VAC
 Iout : 16.7 A (100%)
 Istb : 100 %
 Ta : 25 °C

Conducted Emission

48V

Point A (6.974MHz)		
Ref. Data	Limit (dB)	Measure (dB)
QP	60.0	52.2
AV	50.0	39.3

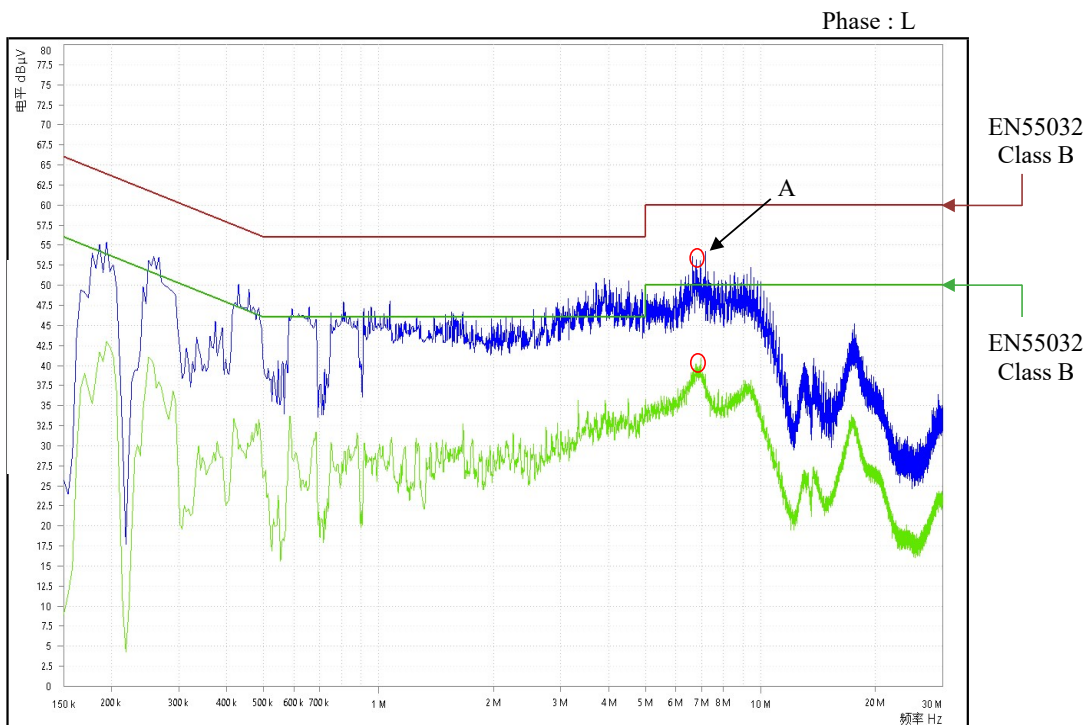

Point B (6.79MHz)		
Ref. Data	Limit (dB)	Measure (dB)
QP	60.0	52.3
AV	50.0	41.8

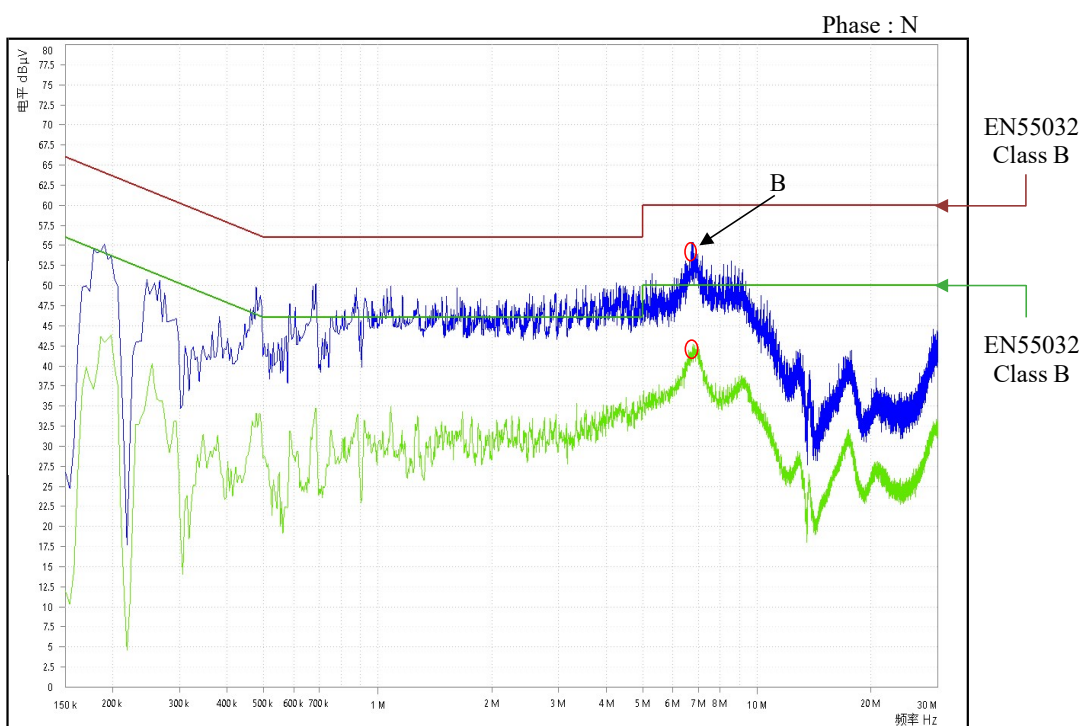

Limit of EN55011-B,FCC-Class B are same as its EN55032-B.

2-15. Electro-Magnetic Interference characteristics

Conditions Vin : 230 VAC
 Iout : 16.7 A (100%)
 Istb : 100 %
 Ta : 25 °C

Conducted Emission

48V

Point A (6.998MHz)		
Ref. Data	Limit (dB)	Measure (dB)
QP	60.0	51.6
AV	50.0	39.5

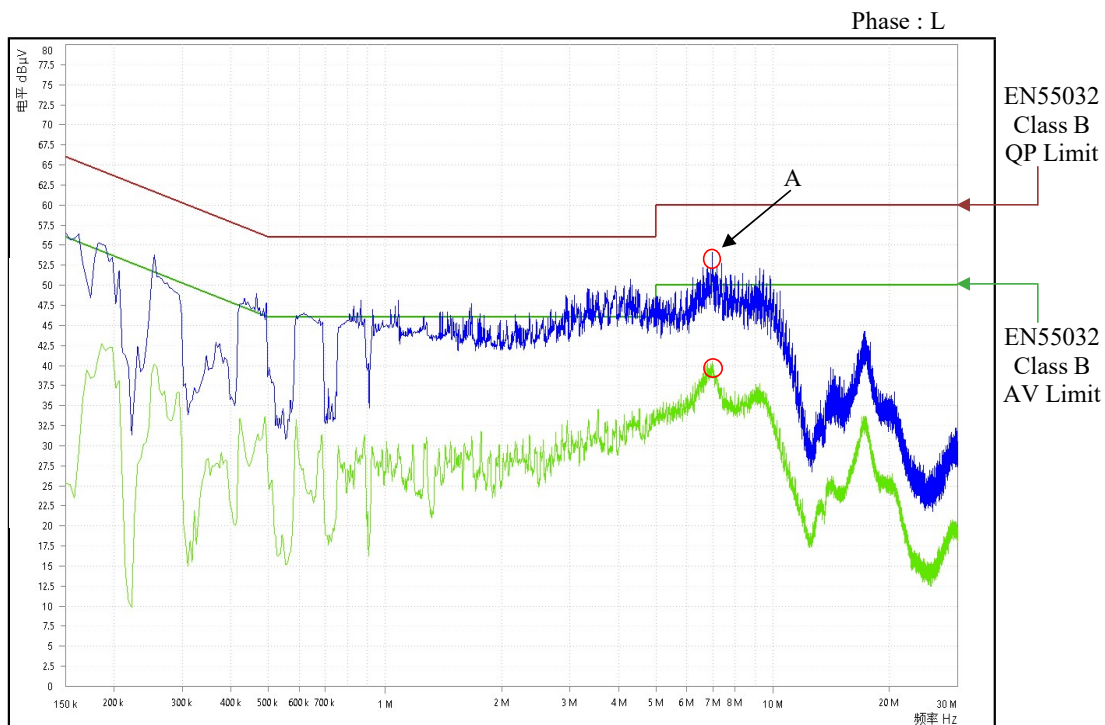

Point B (6.814MHz)		
Ref. Data	Limit (dB)	Measure (dB)
QP	60.0	50.0
AV	50.0	42.3

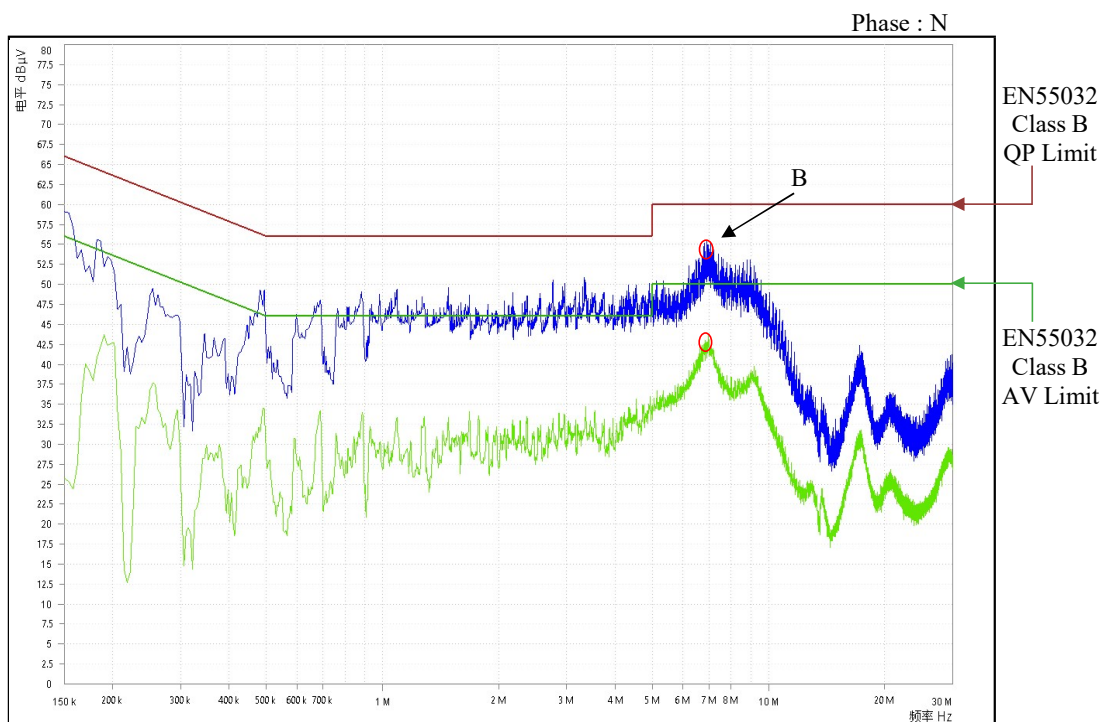

Limit of EN55011-B,FCC-Class B are same as its EN55032-B.

2-15. Electro-Magnetic Interference characteristics

Conditions Vin : 115 VAC
 Iout : 56.7 A (100%)
 Istb : 100 %
 Ta : 25 °C

Radiated Emission

12V

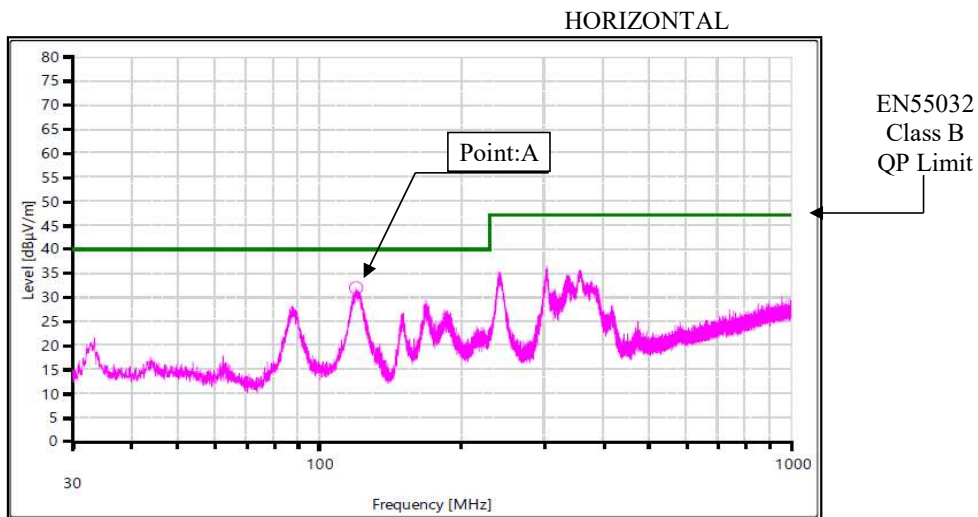

Point A (120MHz)		
Ref.	Data	Measure
QP	40.0	32.0

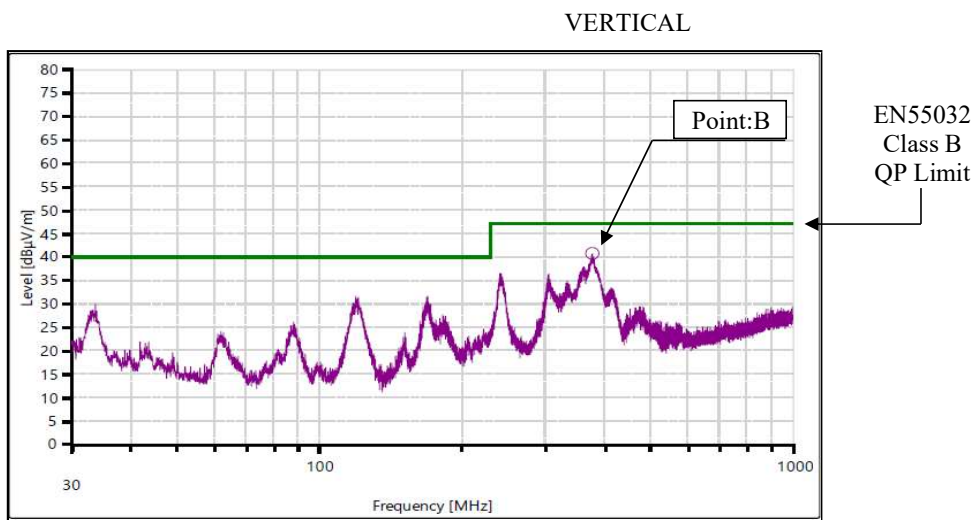

Point B (378MHz)		
Ref.	Data	Measure
QP	47.0	40.7

Limit of EN55011-B,FCC-Class B are same as its EN55032-B.

Indication is peak values.

2-15. Electro-Magnetic Interference characteristics

Conditions Vin : 230 VAC
 Iout : 56.7 A (100%)
 Istb : 100 %
 Ta : 25 °C

Radiated Emission

12V

HORIZONTAL

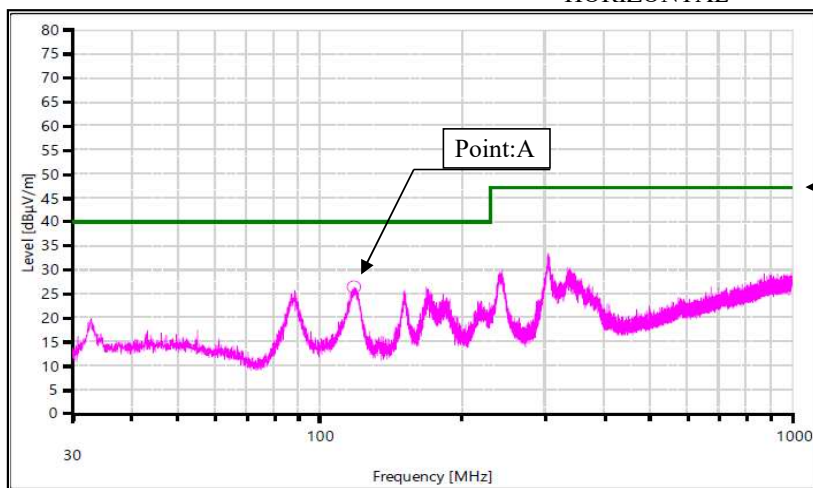

EN55032
 Class B
 QP Limit

Point A (118MHz)		
Ref.	Data	
QP	Limit (dBuV)	Measure (dBuV)
	47.0	26.5

VERTICAL

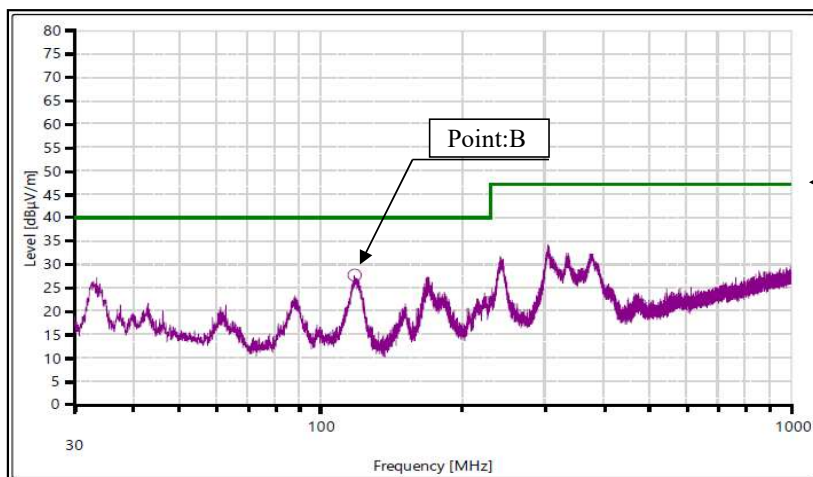

EN55032
 Class B
 QP Limit

Point B (118MHz)		
Ref.	Data	
QP	Limit (dBuV)	Measure (dBuV)
	40.0	27.7

Limit of EN55011-B,FCC-Class B are same as its EN55032-B.

Indication is peak values.

2-15. Electro-Magnetic Interference characteristics

Conditions Vin : 115 VAC
 Iout : 33.4 A (100%)
 Istb : 100 %
 Ta : 25 °C

Radiated Emission

24V

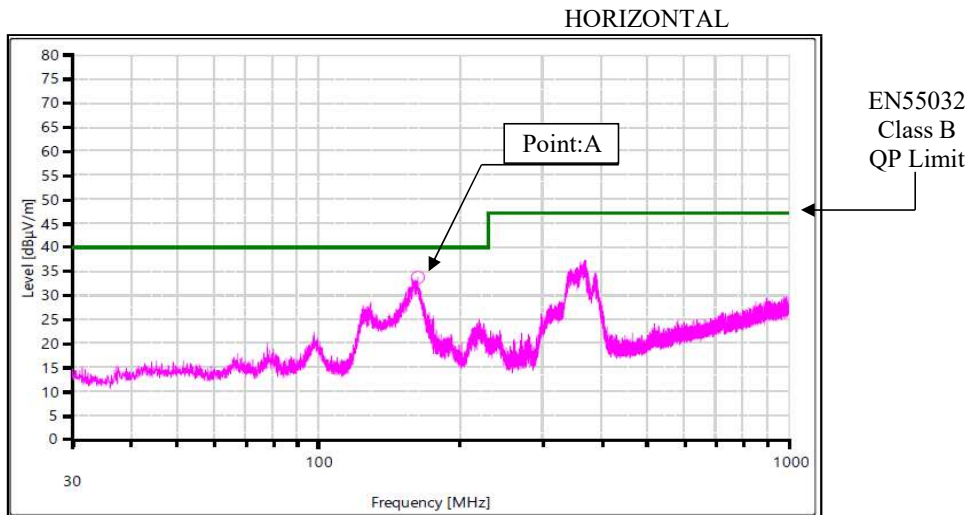

Point A (163MHz)		
Ref.	Data	Measure
QP	40.0	33.7

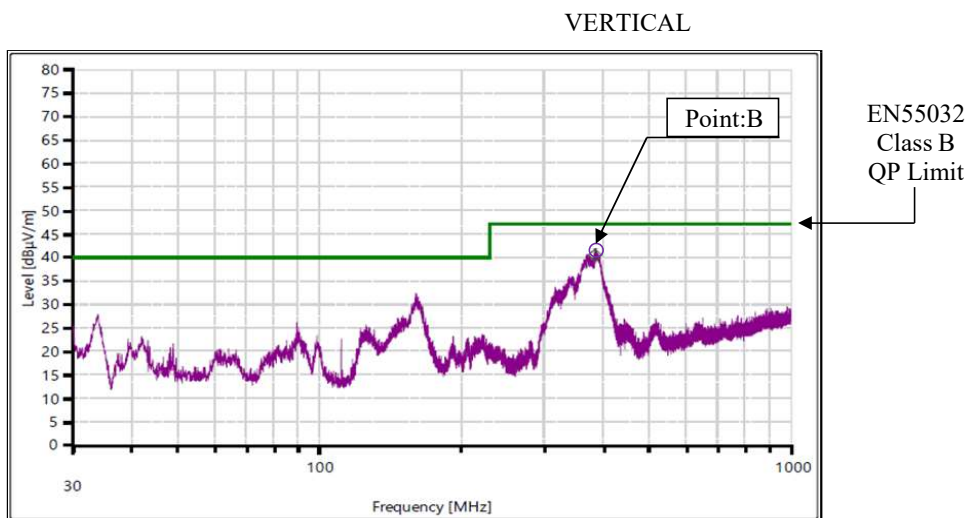

Point B (386MHz)		
Ref.	Data	Measure
QP	47.0	40.4

Limit of EN55011-B,FCC-Class B are same as its EN55032-B.

Indication is peak values.

2-15. Electro-Magnetic Interference characteristics

Conditions Vin : 230 VAC
 Iout : 33.4 A (100%)
 Istb : 100 %
 Ta : 25 °C

Radiated Emission

24V

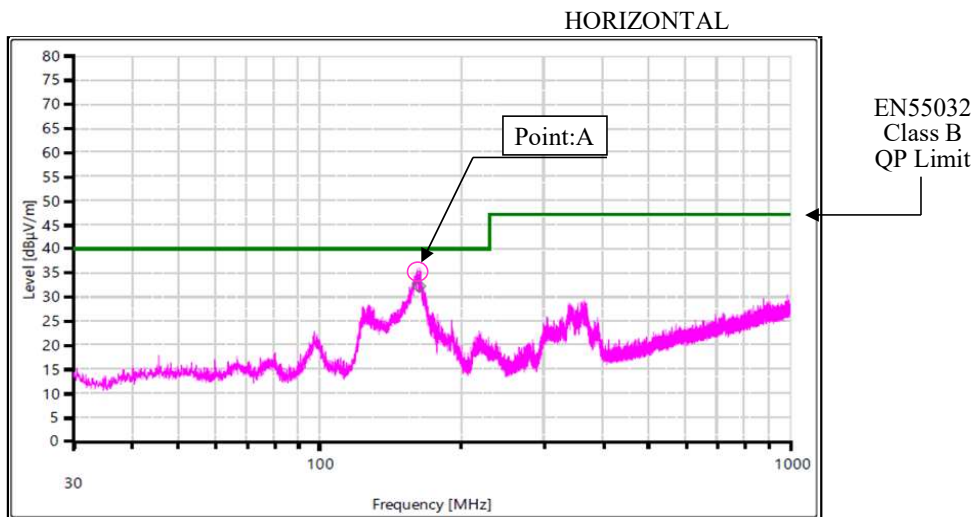

Point A (163MHz)		
Ref.	Data	
QP	Limit (dBµV)	Measure (dBµV)
	40.0	32.3

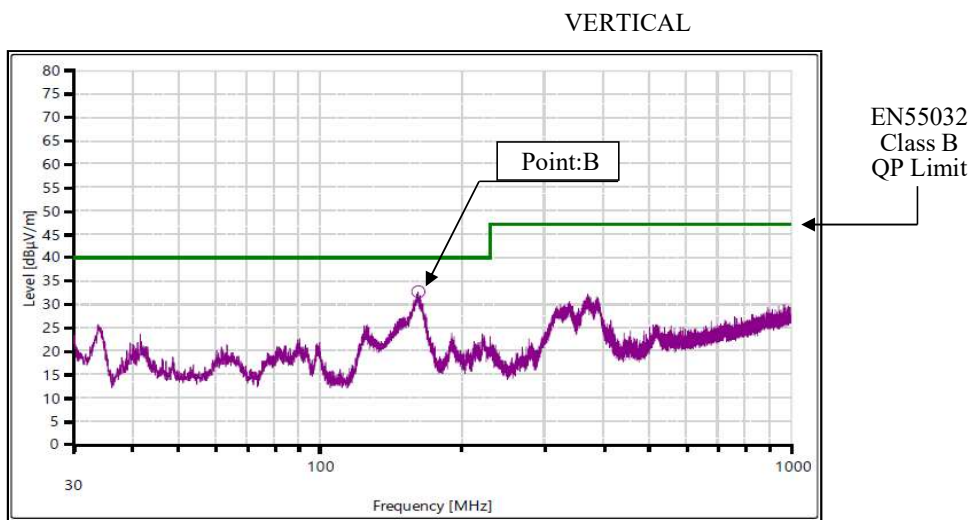

Point B (162MHz)		
Ref.	Data	
QP	Limit (dBµV)	Measure (dBµV)
	40.0	32.8

Limit of EN55011-B,FCC-Class B are same as its EN55032-B.

Indication is peak values.

2-15. Electro-Magnetic Interference characteristics

Conditions Vin : 115 VAC
 Iout : 22.2 A (100%)
 Istb : 100 %
 Ta : 25 °C

Radiated Emission

36V

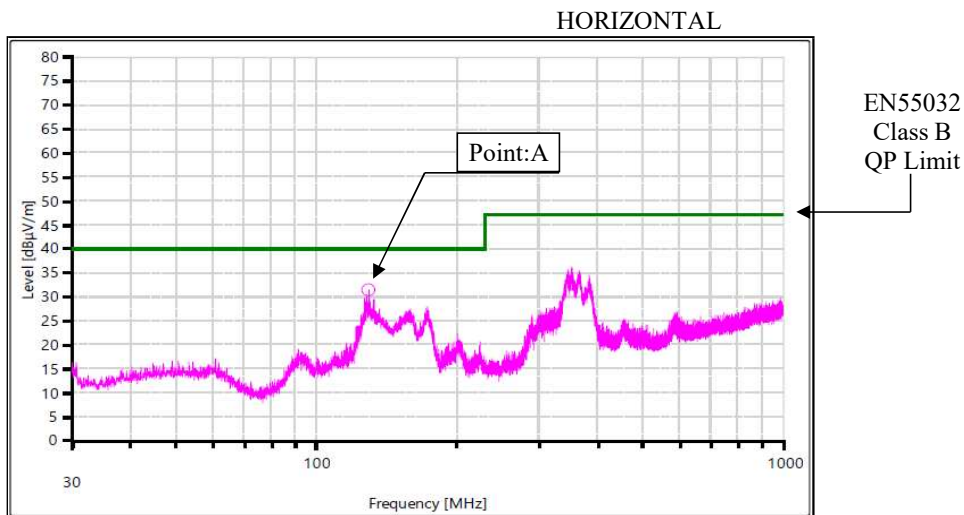

Point A (130MHz)		
Ref.	Data	Limit
QP	40.0	31.4

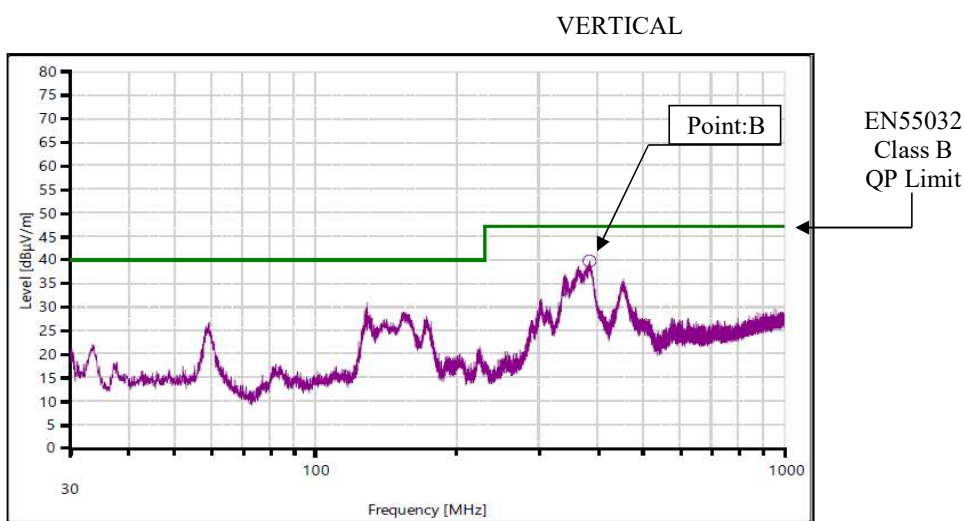

Point B (386MHz)		
Ref.	Data	Limit
QP	47.0	39.7

Limit of EN55011-B,FCC-Class B are same as its EN55032-B.

Indication is peak values.

2-15. Electro-Magnetic Interference characteristics

Conditions Vin : 230 VAC
 Iout : 22.2 A (100%)
 Istb : 100 %
 Ta : 25 °C

Radiated Emission

36V

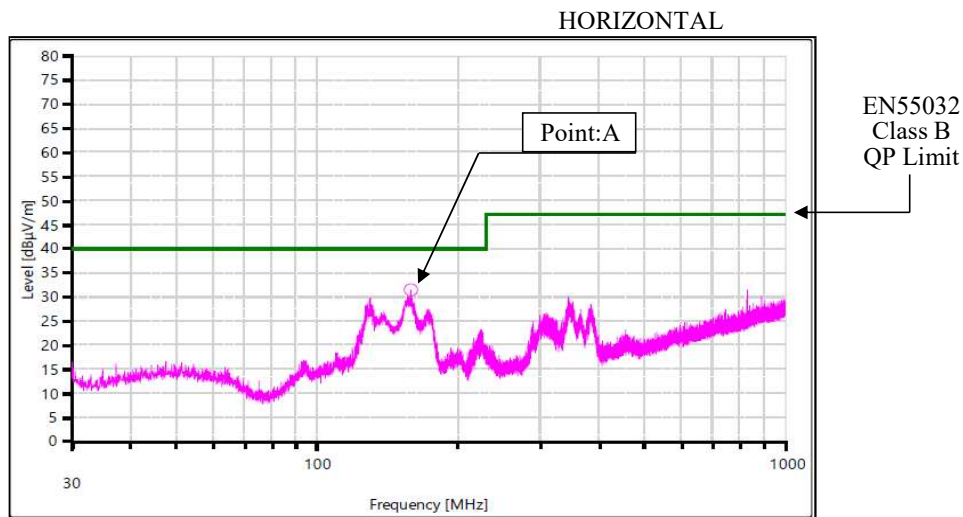

Point A (159MHz)		
Ref.	Limit	Measure
Data	(dBuV)	(dBuV)
QP	40.0	31.6

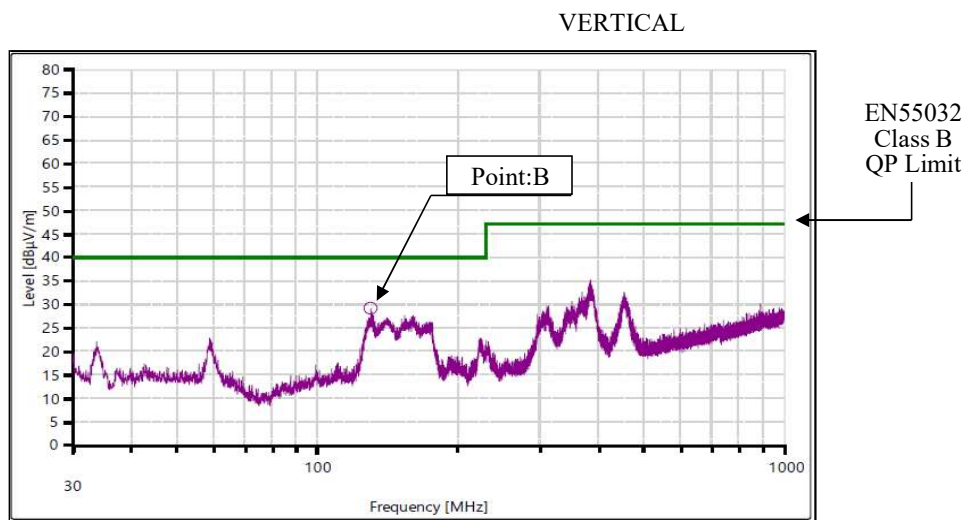

Point B (130MHz)		
Ref.	Limit	Measure
Data	(dBuV)	(dBuV)
QP	40.0	29.2

Limit of EN55011-B,FCC-Class B are same as its EN55032-B.

Indication is peak values.

2-15. Electro-Magnetic Interference characteristics

Conditions Vin : 115 VAC
 Iout : 16.7 A (100%)
 Istb : 100 %
 Ta : 25 °C

Radiated Emission

48V

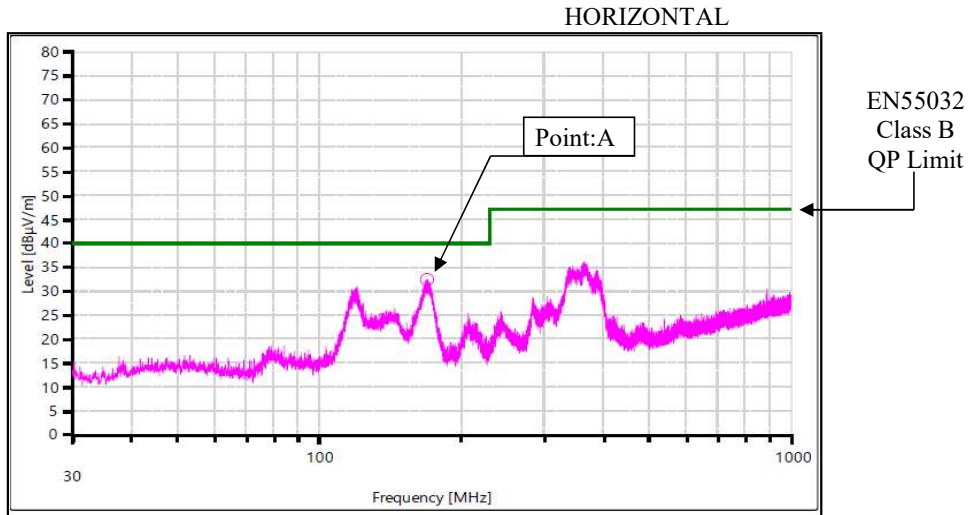

Point A (169MHz)		
Ref.	Data	Limit
QP	40.0	32.5

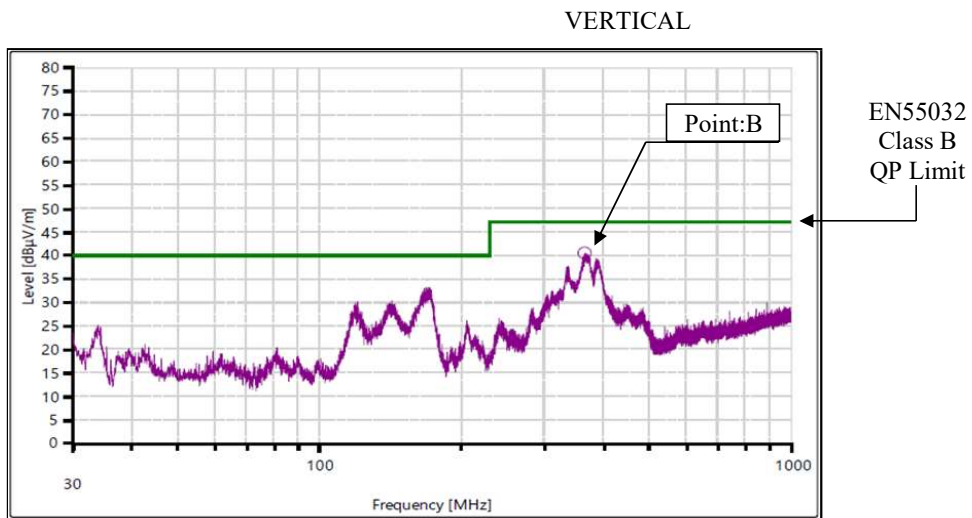

Point B (367MHz)		
Ref.	Data	Limit
QP	47.0	40.4

Limit of EN55011-B,FCC-Class B are same as its EN55032-B.

Indication is peak values.

2-15. Electro-Magnetic Interference characteristics

Conditions Vin : 230 VAC
 Iout : 16.7 A (100%)
 Istb : 100 %
 Ta : 25 °C

Radiated Emission

48V

HORIZONTAL

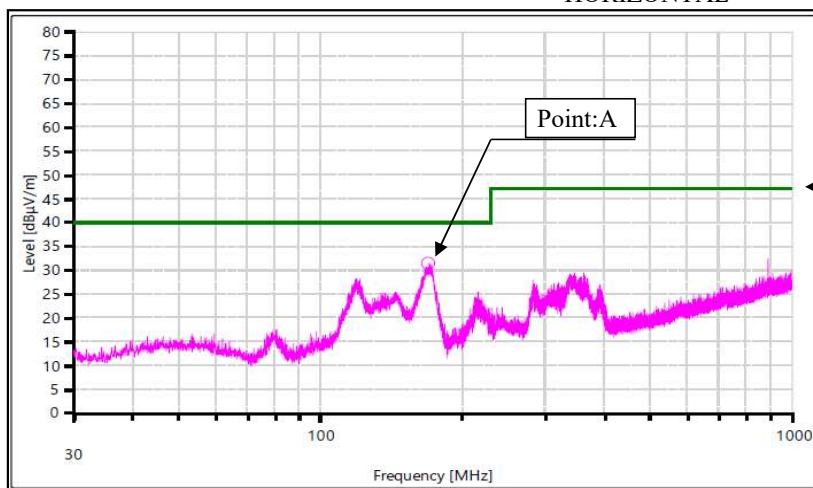

Point A (170MHz)		
Ref.	Data	Limit
QP	40.0	31.5

VERTICAL

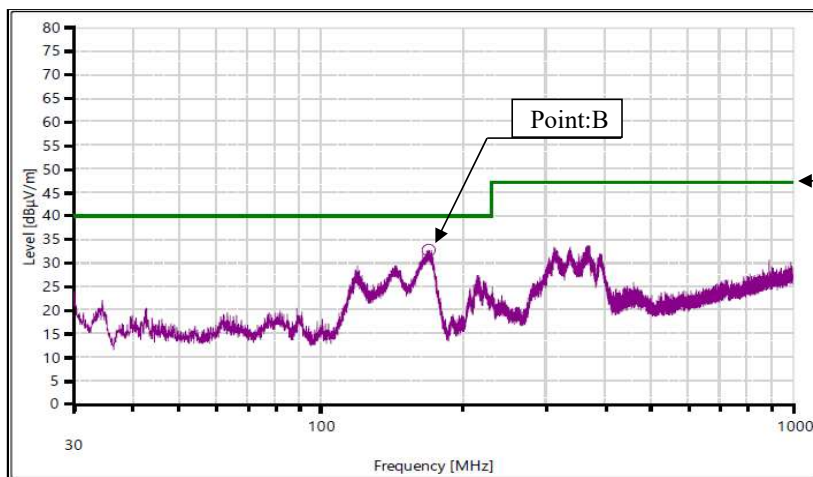

Point B (169MHz)		
Ref.	Data	Limit
QP	40.0	32.8

Limit of EN55011-B,FCC-Class B are same as its EN55032-B.

Indication is peak values.

2-16.Audible Noise of FAN

Test condition: Background noise: 23 [dB(A)]
 Test duration: 60 [s]
 Vin: 115VAC @ 60Hz ————
 230VAC @ 50Hz - - - - -
 Iout: 100% (33.4A)
 Istb: 100% (2A)
 Ta: 25°C

Test equipment :

Sound Calibrator: Type 4231 (B&K)

Audio Analyzer: Type 3560-C (B&K)

Test Method :

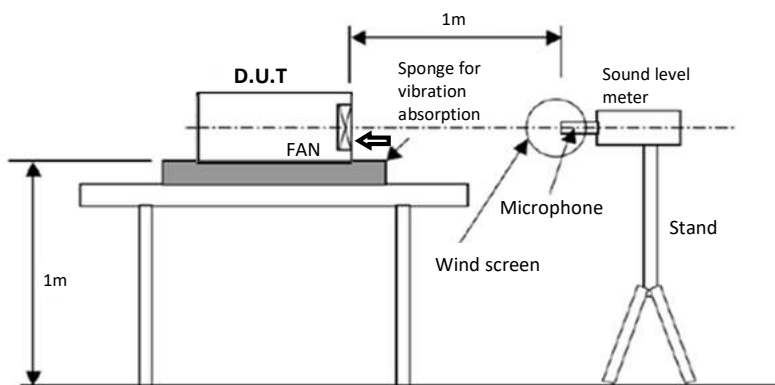

Basic setting of sound measurements

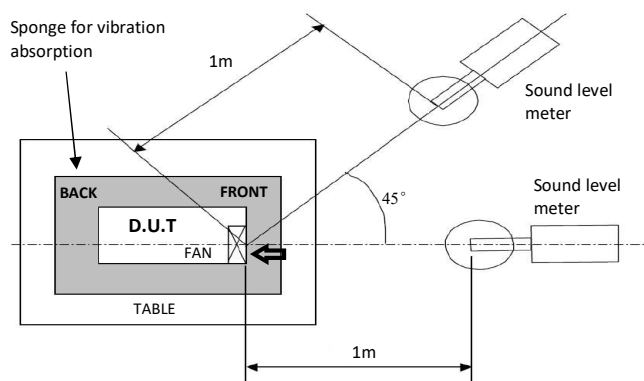

Position of a sound meter intake surface (air inlet)

Audible Noise Curve of FAN:

