

DLP240-24-1

EVALUATION DATA

INDEX

	PAGE
1. Evaluation Method	
1.1 Circuit used for determination	T-1~5
(1) Steady state data	
(2) Warm up voltage drift characteristics	
(3) Over current protection (OCP) characteristics	
(4) Over voltage protection (OVP) characteristics	
(5) Output rise characteristics	
(6) Output fall characteristics	
(7) Dynamic line response characteristics	
(8) Input voltage dip test	
(9) Dynamic load response characteristics	
(10) Inrush current characteristics	
(11) Leakage current characteristics	
(12) Output ripple and noise waveform	
(13) Stand-by current	
(14) Electro Magnetic Interference characteristics	
1.2 List of equipment used	T-6
2. Characteristics	
2.1 Steady state data	
(1) Regulation - line and load, temperature drift	T-7
(2) Output voltage and ripple voltage vs. input voltage	T-8
(3) Efficiency and input current vs. output current	T-9
(4) Power factor and input current vs.output current	T-10
2.2 Warm up voltage drift characteristics	T-11
2.3 Over current protection (OCP) characteristics	T-12
2.4 Over voltage protection (OVP) characteristics	T-13
2.5 Output rise characteristics	T-14~15
2.6 Output fall characteristics	T-16~17

2.7 Dynamic line response characteristics	T-18
2.8 Input voltage dip test	T-19
2.9 Dynamic load response characteristics	T-20
2.10 Response to brown out characteristics	T-21
2.11 Inrush current waveform	T-22~23
2.12 Input current waveform	T-24
2.13 Input current harmonics	T-25
2.14 Leakage current characteristics	T-26
2.15 Output ripple and noise waveform	T-27~28
2.16 Stand-by current	T-29
2.17 Hold up time characteristics	T-30
2.18 Electro Magnetic Interference characteristics	T-31~34

Terminology used

	Definition
V_{in}	Input voltage
V_{out}	Output voltage
I_{in}	Input current
I_{out}	Output current
T_a	Ambient temperature

1.1 Circuit used for determination

(1) Steady state data

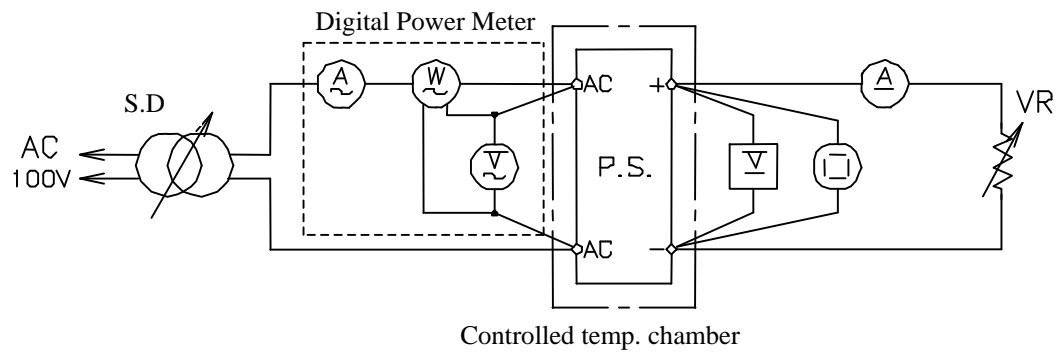

(2) Warm up voltage drift characteristics

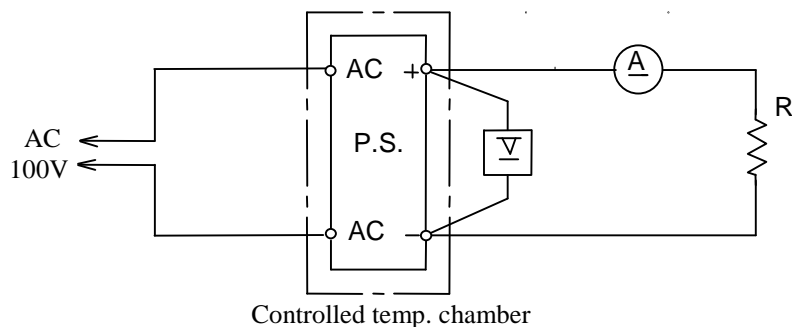

(3) Over current protection (O.C.P) characteristics

Same as steady state data.

(4) Over voltage protection (O.V.P) characteristics

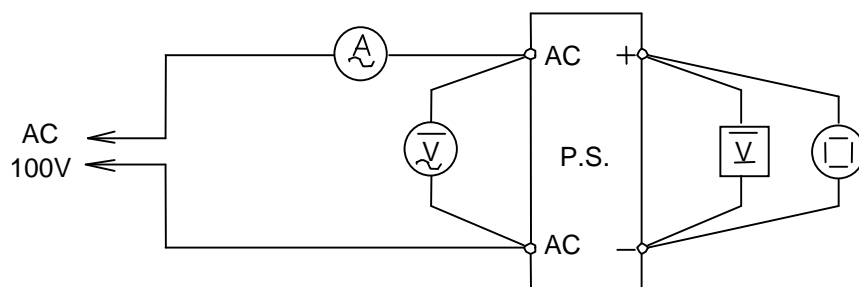

(5) Output rise characteristics

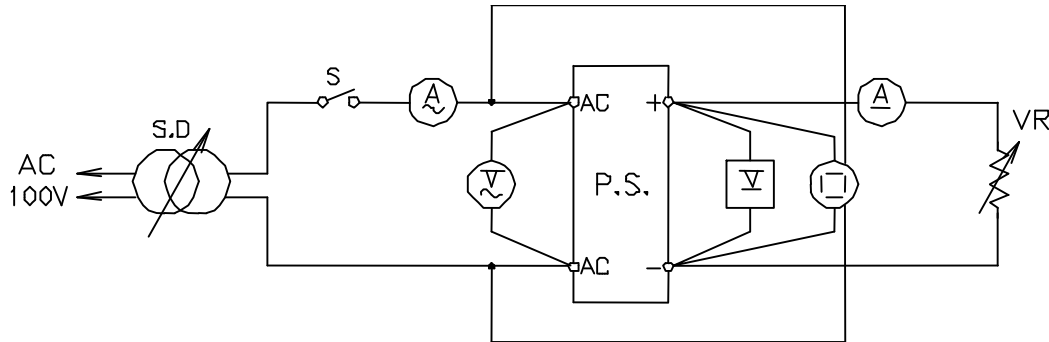

(6) Output fall characteristics

Same as output rise characteristics.

(7) Dynamic line response characteristics

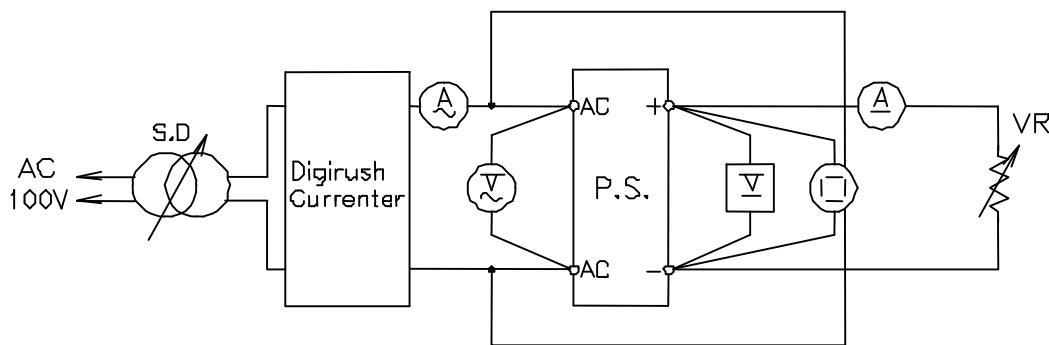

(8) Input voltage dip test

Same as Dynamic line response characteristics.

(9) Dynamic load response characteristics

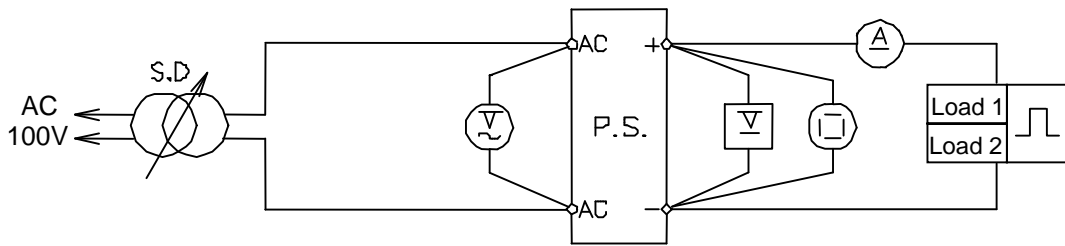

Output current waveform :
Iout 0% ↔ Full load

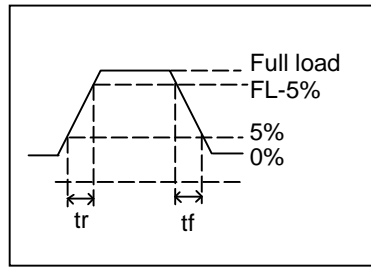

Output current waveform :
Iout 50% ↔ Full load

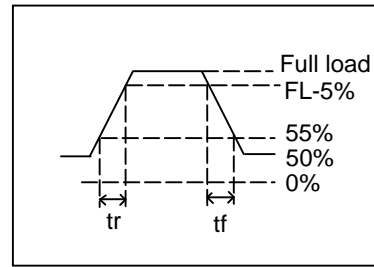

(10) Inrush current characteristics

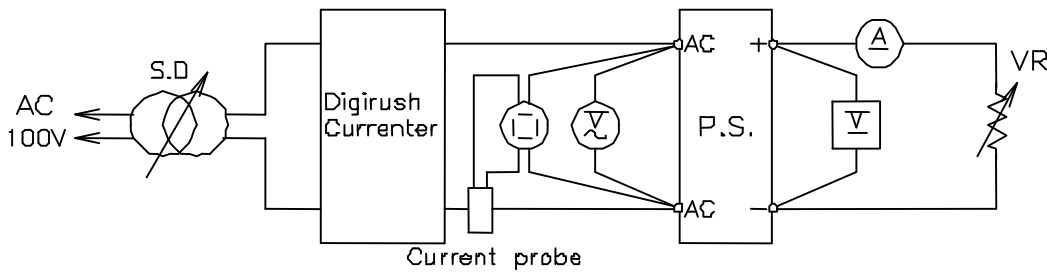

(11) Leakage current characteristics

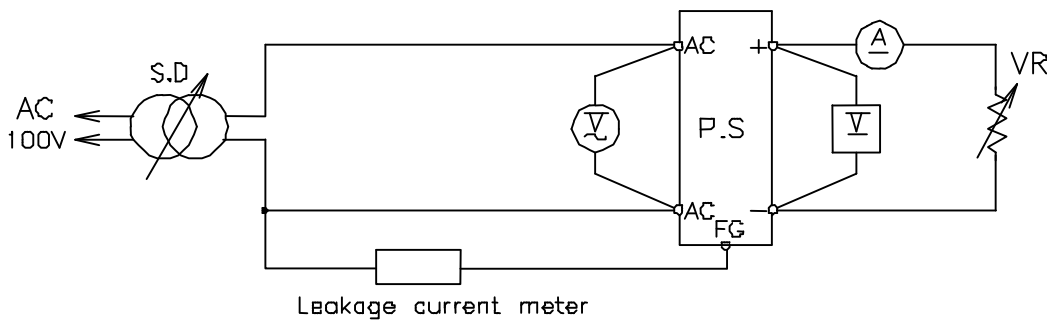

Note : Leakage current measured through a 1k ohm resistor.
Range used : AC + DC
For SIMPSON MODEL 228 and YOKOGAWA TYPE 3226

(12) Output - ripple, noise waveform

(a) Normal Mode (JEITA Standard RC-9131)

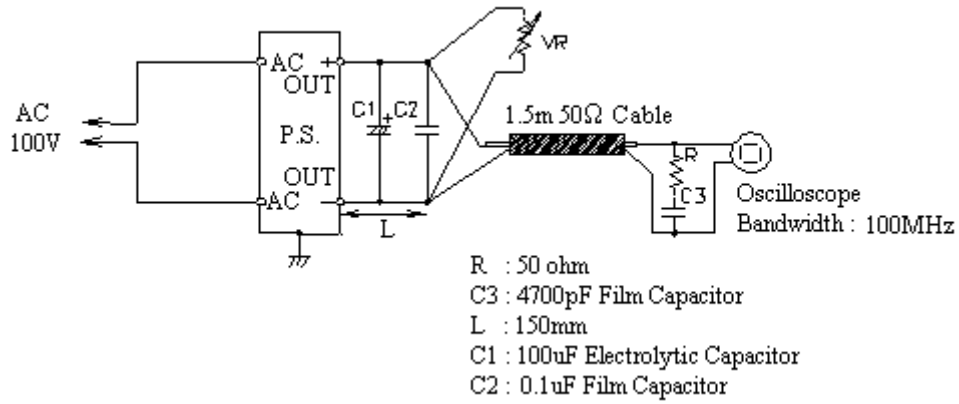

(b) Normal + Common Mode

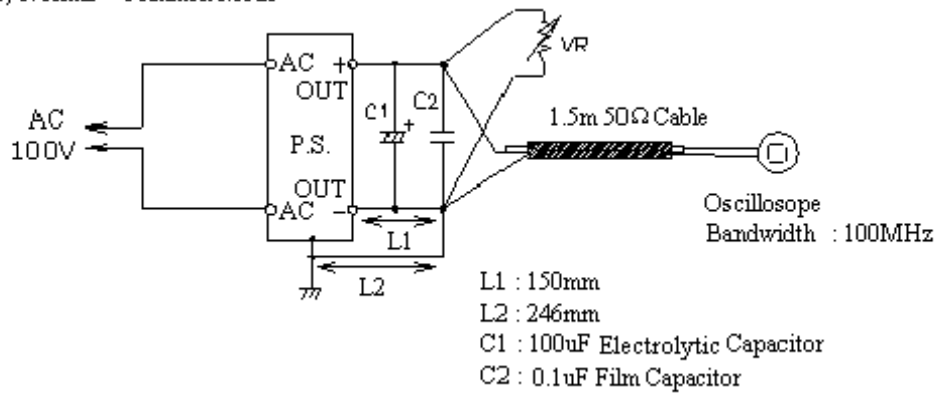

(13) Stand-by current

Same as steady state data

(14) Electro-Magnetic Interference characteristics

(a) Conducted Emission Noise

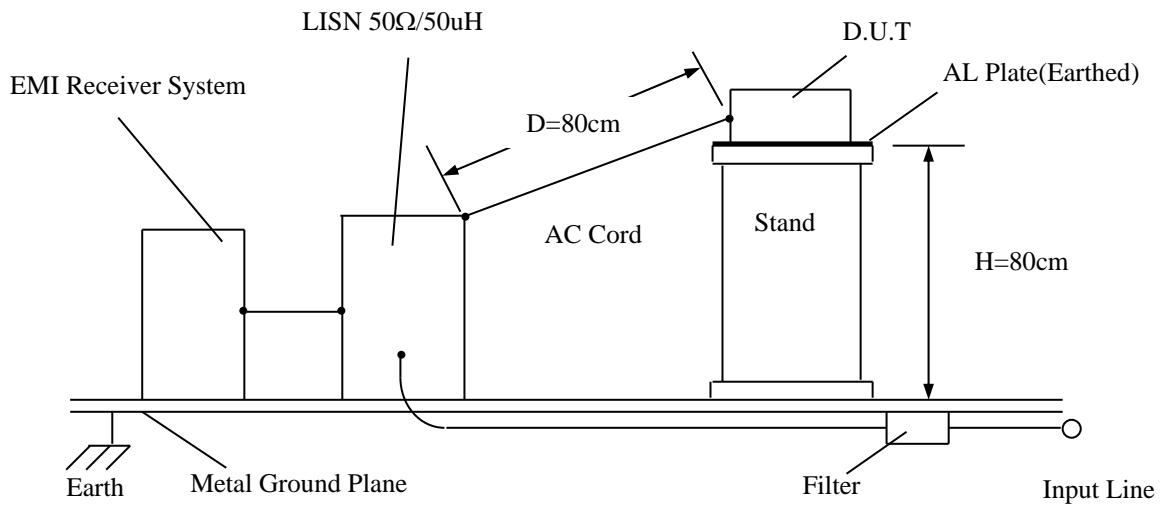

(b) Radiated Emission Noise

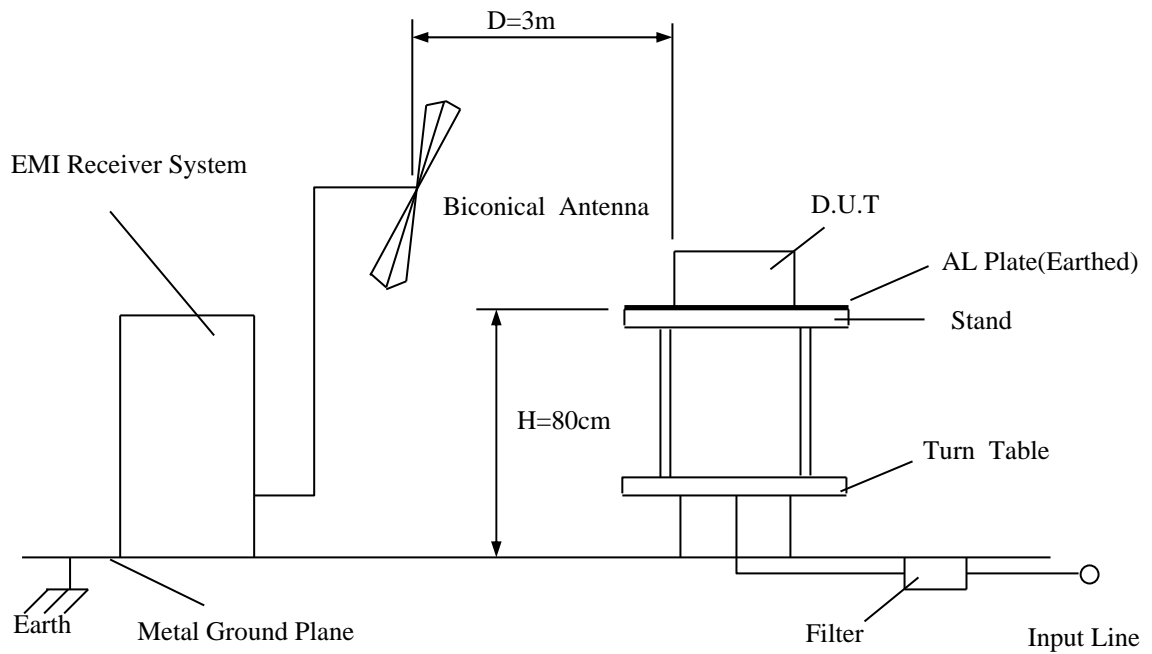

1.2 LIST OF EQUIPMENT USED

	EQUIPMENT USED	MANUFACTURER	MODEL NO.
1	Oscilloscope	HITACHI	V-1050F
2	Digital storage oscilloscope	TEKTRONIX	TDS 714L
3	Digital volt meter	LEADER	856
4	Digital power meter	YOKOGAWA	2533
5	DC ampere meter	YOKOGAWA	2051
6	Dynamic dummy load	KIKUSUI	PLZ152W
7	Current probe/amplifier	TEKTRONIX	A6303/AM503B
8	Controlled temperature chamber	TABAI-ESPEC	SU-240
9	Leakage current meter	SIMPSON	228
10	Digirush currenter	TAKAMIZAWA CYBERNETICS	PSA-200
11	EMI receiver	HEWLETT PACKARD	HP8546A
12	LISN	EMCO	3825/2
13	Biconical antenna	EMCO	3110B

2. Characteristics

2.1 Steady state data

(1) Regulation - line and load, temperature drift

24V

1. Regulation-line and load

condition Ta : 25°C

Iout \ Vin	85VAC	100VAC	230VAC	265VAC	line regulation	
0%	24.031V	24.030V	24.031V	24.031V	0.001V	0.004%
50%	24.015V	24.013V	24.016V	24.013V	0.003V	0.013%
100%	23.995V	23.992V	23.995V	23.990V	0.005V	0.021%
load regulation	0.036V	0.038V	0.036V	0.041V		
	0.150%	0.158%	0.150%	0.171%		

2. Temperature drift

conditions Vin = 100VAC

Iout = 100%

Ta	-10°C	+25°C	+50°C	temperature stability	
Vout	24.007	23.992	23.9	0.107V	0.446%

2.1 (2) Output voltage and Ripple voltage v.s. Input voltage

Conditions Iout : 100%
Ta : -10°C-----
: 25°C- - - - -
: 50°C—————

24V

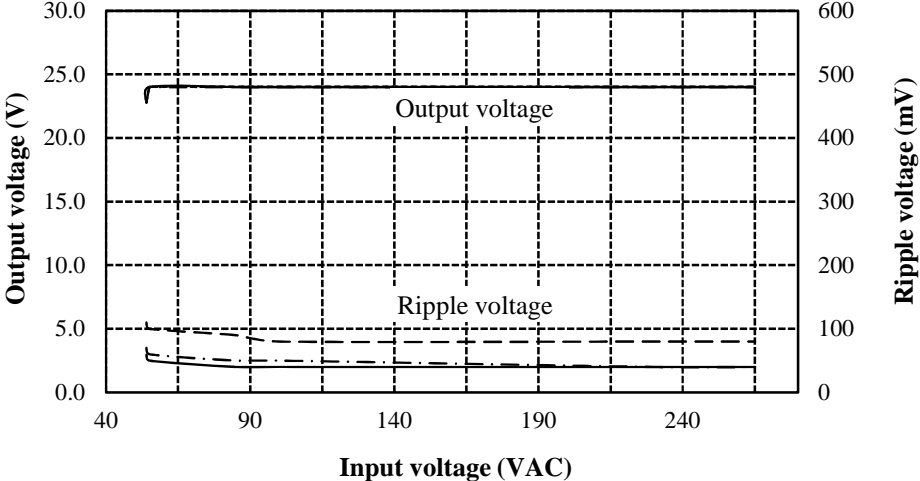

2.1 (3) Efficiency and input current v.s. Output current

Conditions V_{in} : 85VAC -----
 : 100VAC - - - - -
 : 230VAC ————
 : 265VAC ······
 T_a : 25°C

24V

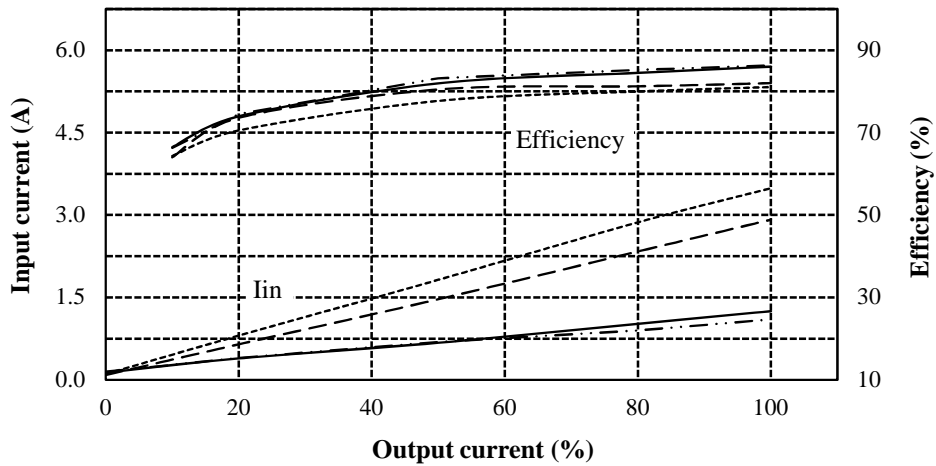

2.1 (4) Power factor and Input current v.s Output current

Conditions V_{in} : 85VAC -----
 : 100VAC -----
 : 230VAC -----
 : 265VAC -----
 T_a : 25°C

24V

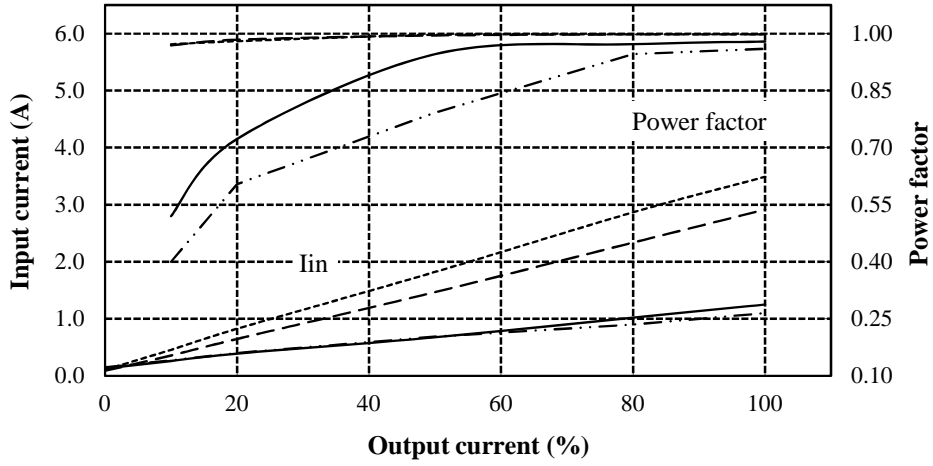

2.2 Warm up voltage drift characteristics

Condition: Vin : 100VAC
Iout : 100%
Ta : 25°C

24V

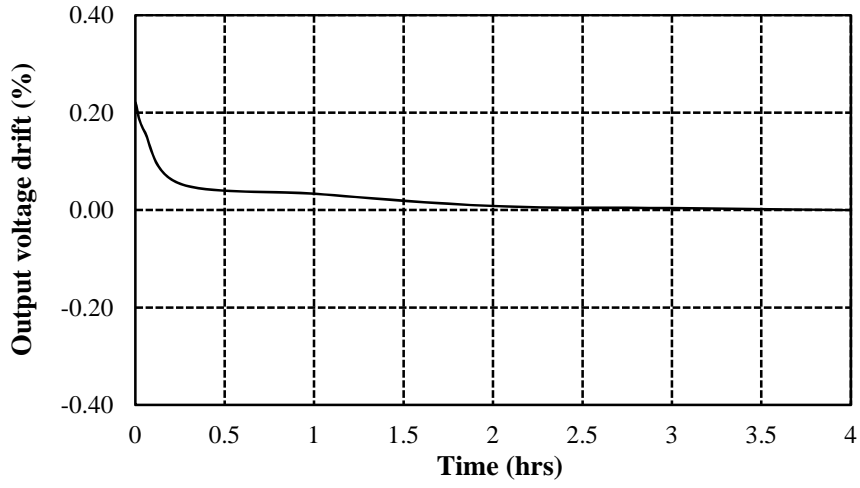

2.3 Over current protection (OCP) characteristics

Conditions Vin : 85VAC (A) Ta : -10°C -----
: 100VAC (B) : 25°C
: 200VAC (C) : 50°C -----
: 265VAC (D)

24V

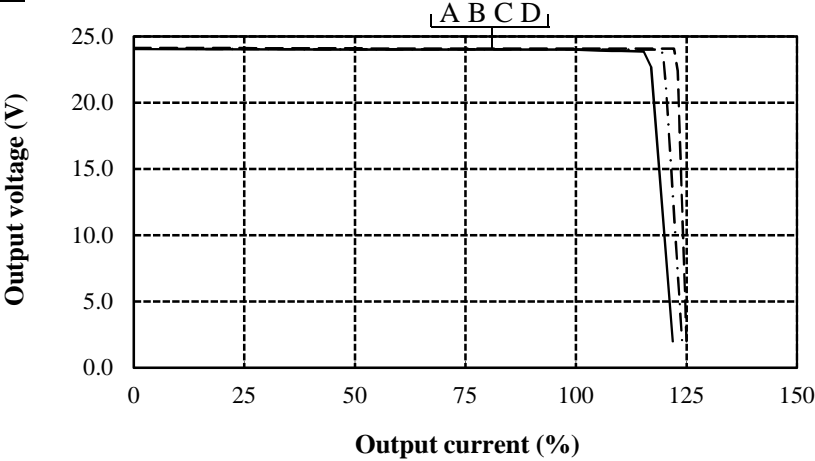

2.4 Over voltage protection (OVP) characteristics

Conditions Vin : 100VAC
Iout : 0%
Ta : 25°C

24V

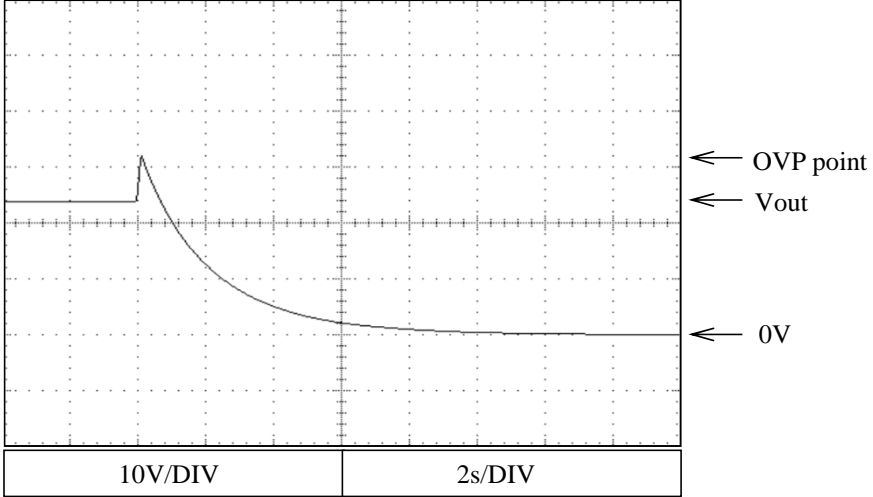

DLP240-24-1

2.5 Output rise characteristics

Conditions Vin : 85VAC (A)
: 100VAC (B)
: 230VAC (C)
: 265VAC (D)
Iout : 0%

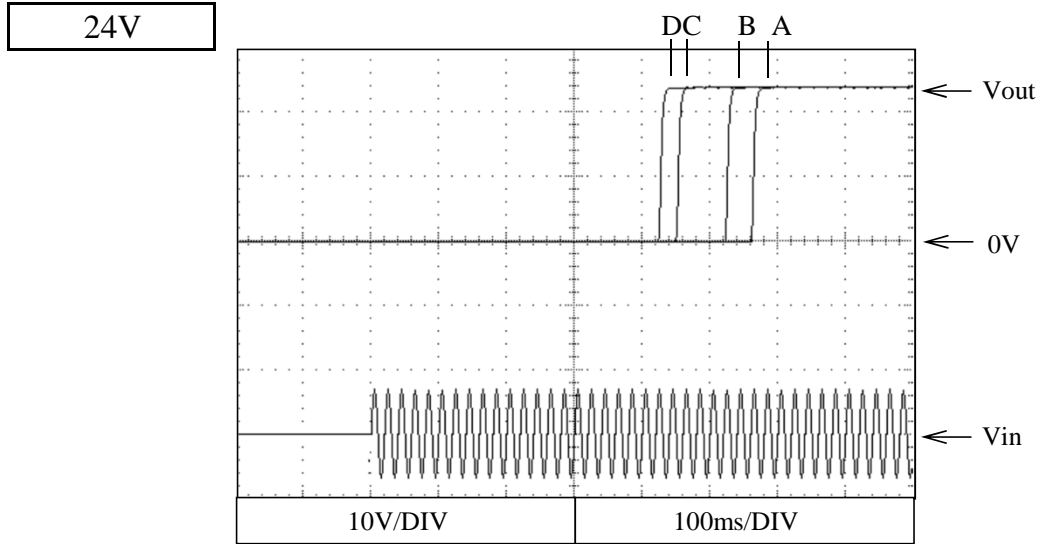

DLP240-24-1

2.5 Output rise characteristics

Conditions Vin : 85VAC (A)
: 100VAC (B)
: 230VAC (C)
: 265VAC (D)
Iout : 100%

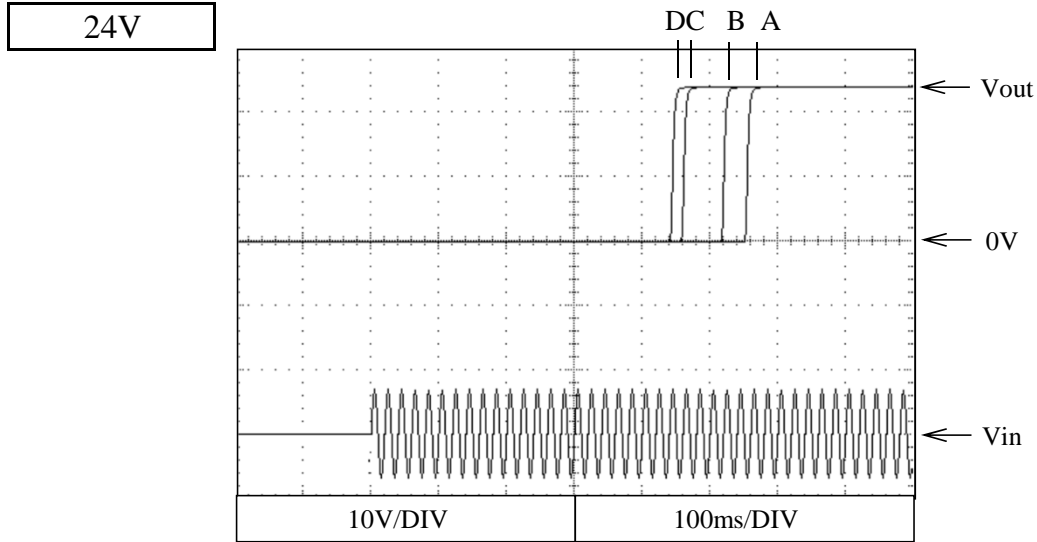

DLP240-24-1

2.6 Output fall characteristics

Conditions Vin : 85VAC (A)
: 100VAC (B)
: 230VAC (C)
: 265VAC (D)
Iout : 0%

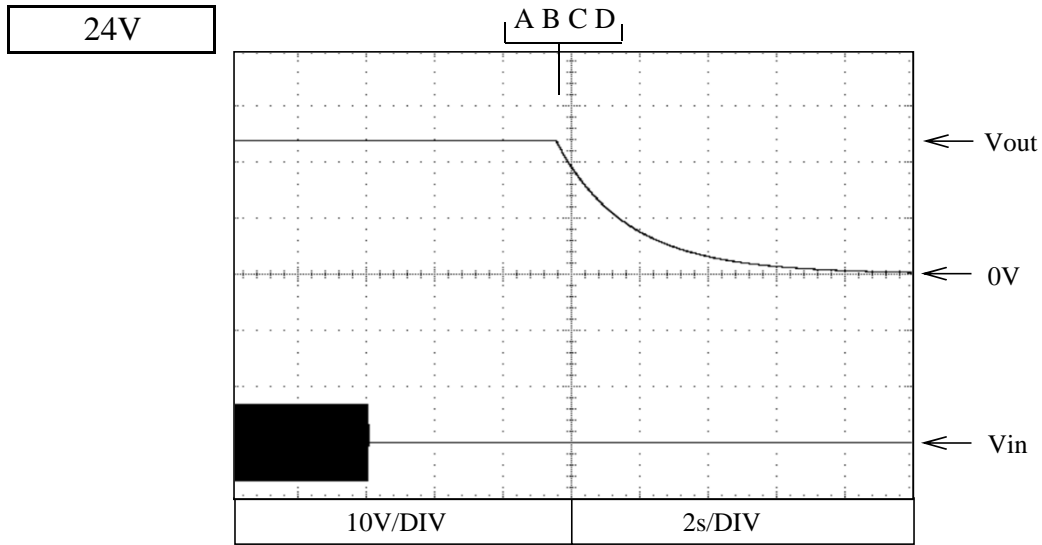

DLP240-24-1

2.6 Output fall characteristics

Conditions V_{in} : 85VAC (A)
 : 100VAC (B)
 : 230VAC (C)
 : 265VAC (D)
 I_{out} : 100%

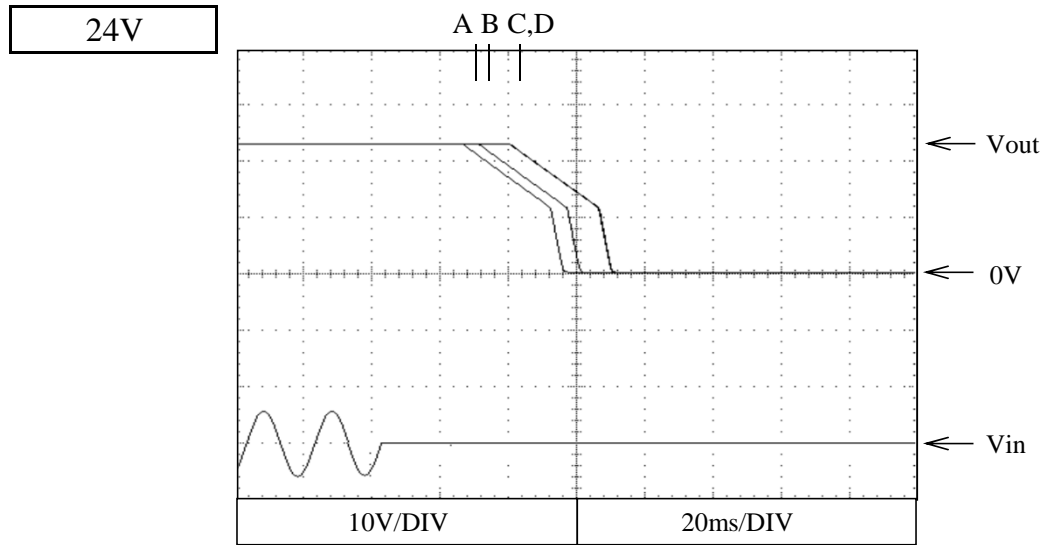

DLP240-24-1

2.7 Dynamic line response characteristics

Conditions Vin : 85VAC ↔ 132VAC(A)
170VAC ↔ 265VAC(B)
Iout : 100%
Ta : 25°C

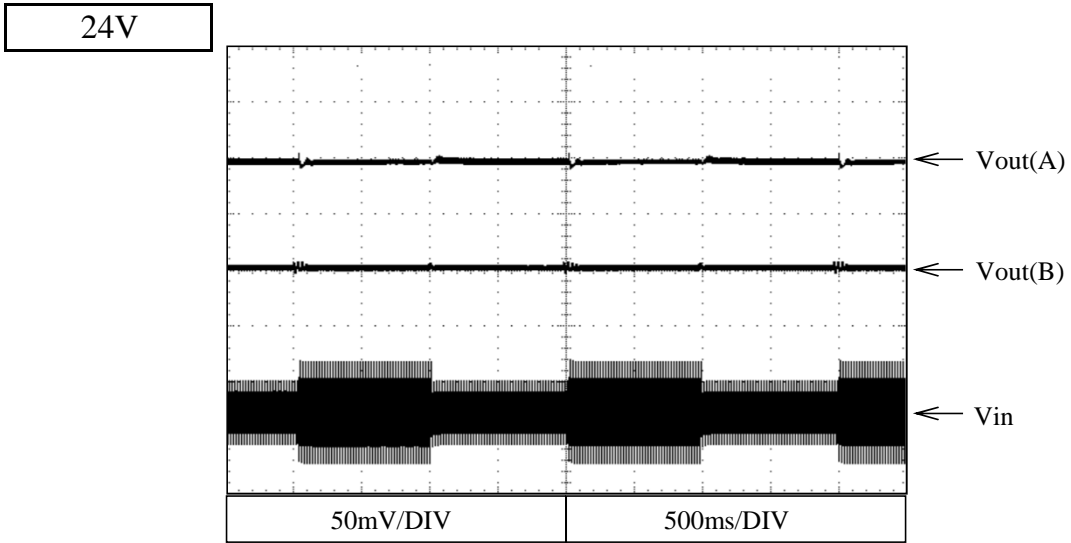

2.8 Input voltage dip test

Conditions Ta : 25°C
Iout : 100%

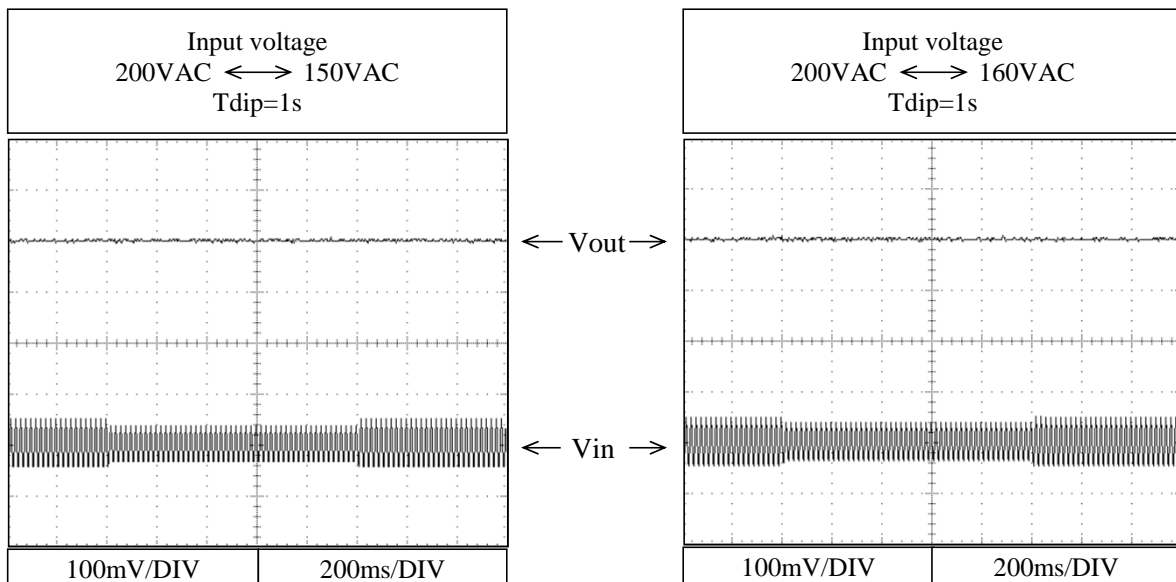
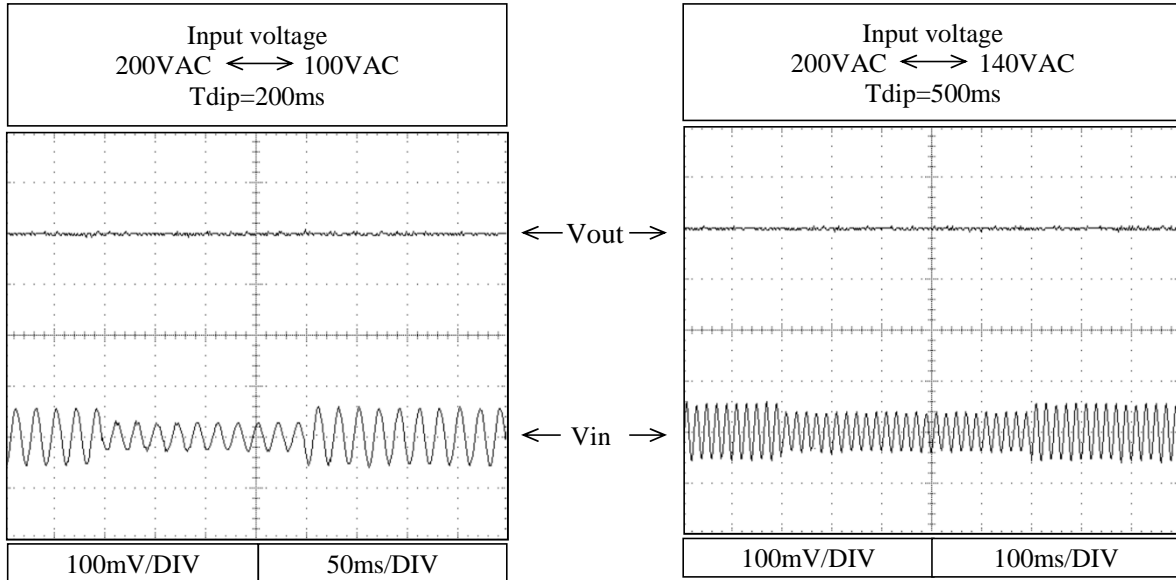

2.9 Dynamic load response characteristics

Conditions Vin : 100VAC
Ta : 25°C

24V

f=100Hz

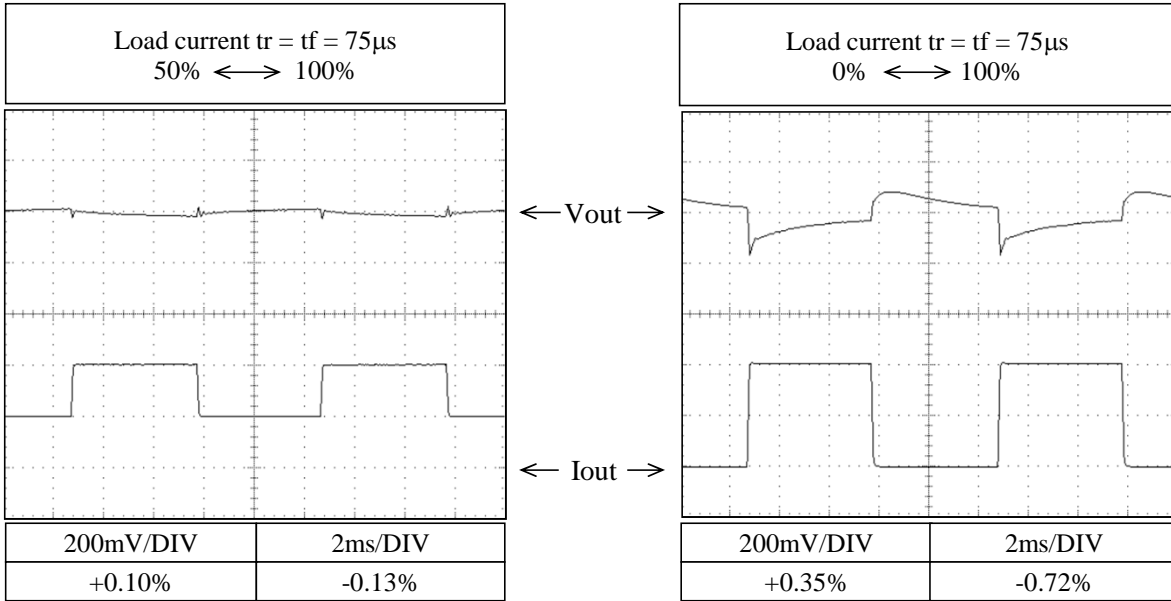

f=1kHz

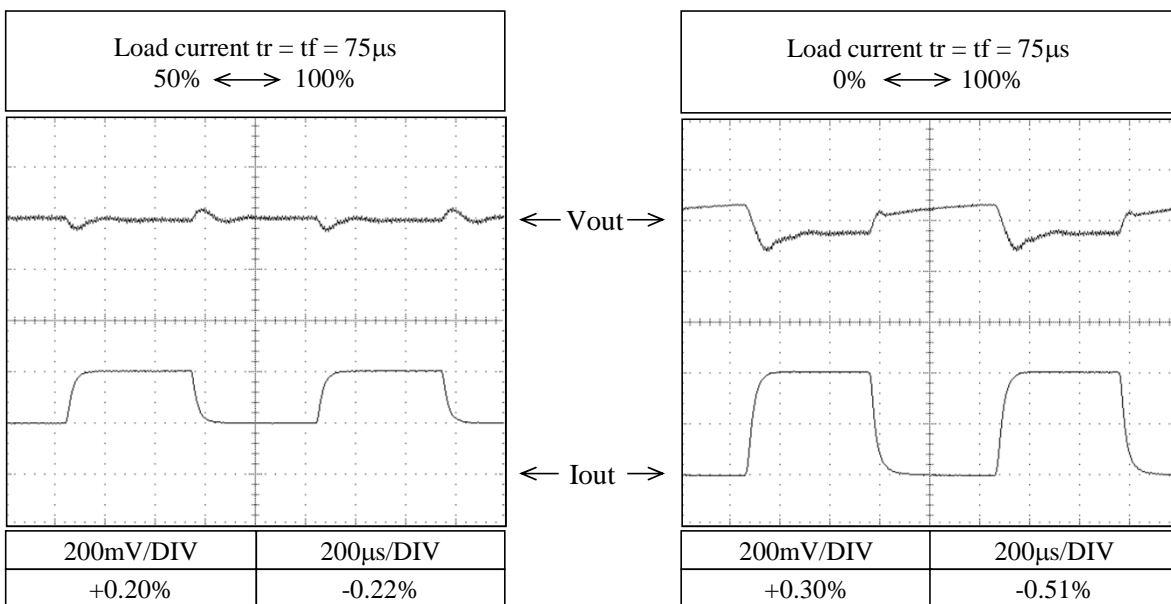

2.10 Response to brown out characteristics

Conditions Vin : 100VAC
Iout : 100%
Ta : 25°C

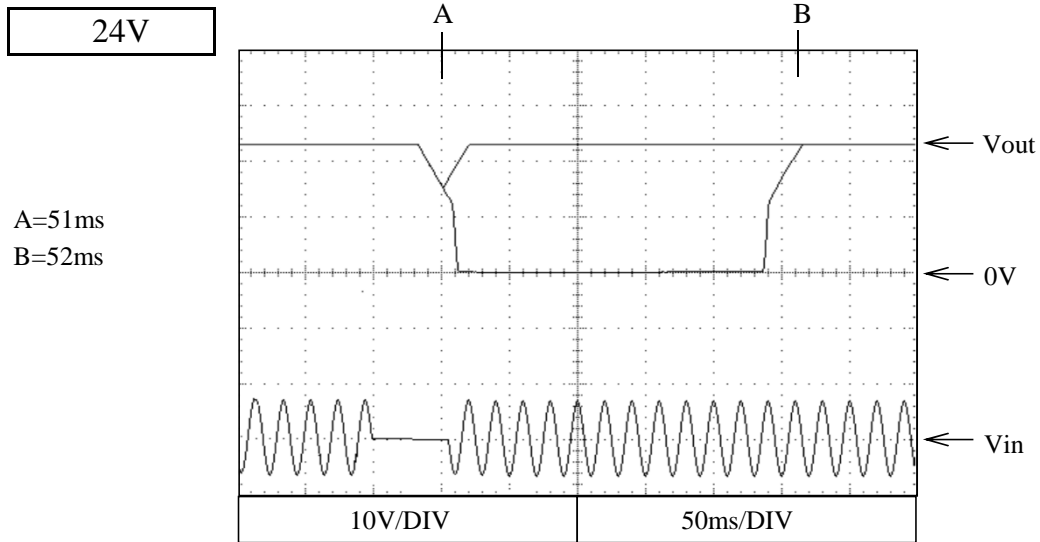

Conditions Vin : 230VAC
Iout : 100%
Ta : 25°C

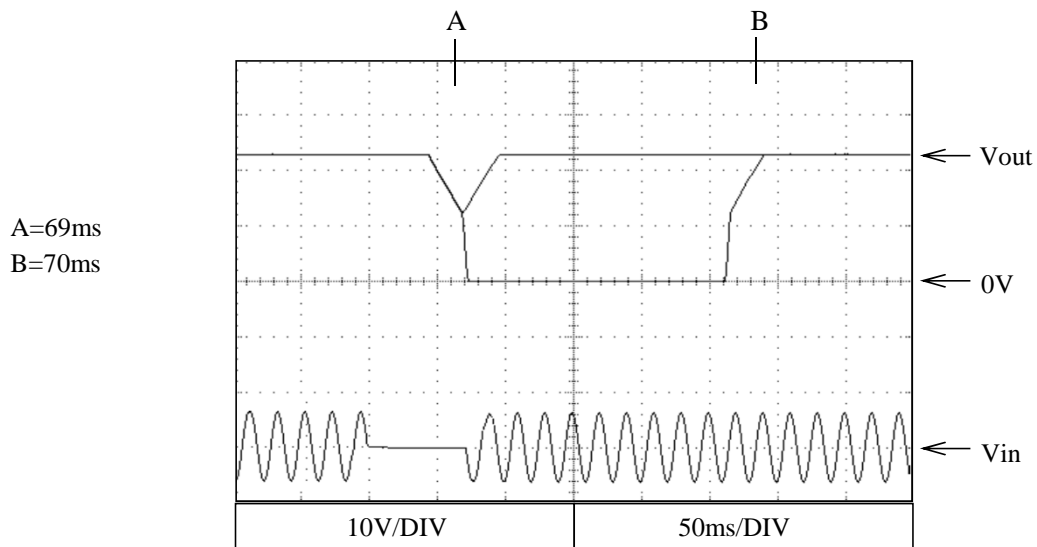

2.11 Inrush current waveform

Conditions Vin : 100VAC
Iout : 100%
Ta : 25°C

24V

Switch on phase angle
of input AC voltage
 $\phi = 0^\circ$

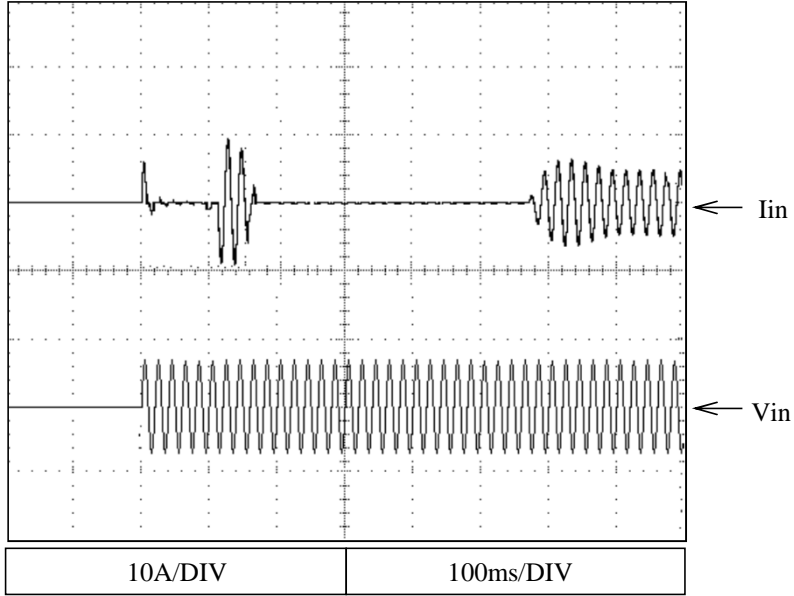

Switch on phase angle
of input AC voltage
 $\phi = 90^\circ$

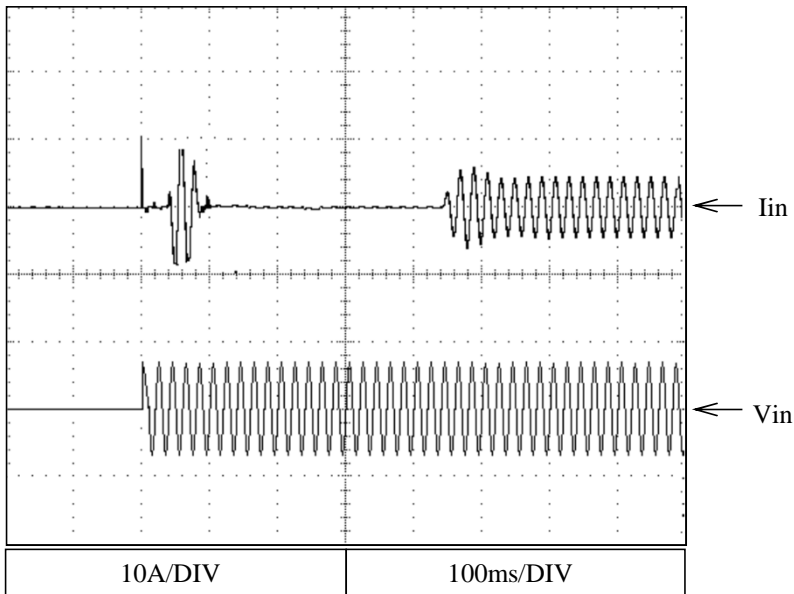

2.11 Inrush current waveform

Conditions Vin : 230VAC
Iout : 100%
Ta : 25°C

24V

Switch on phase angle
of input AC voltage
 $\phi = 0^\circ$

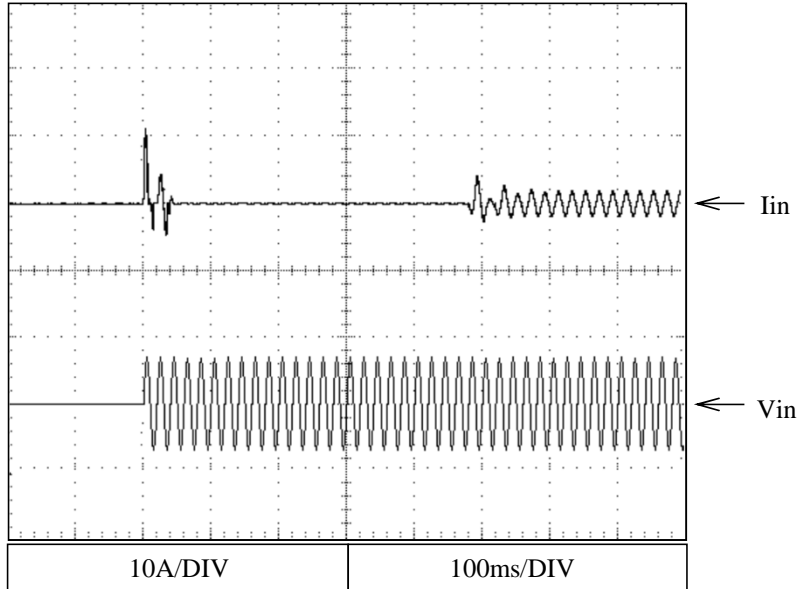

Switch on phase angle
of input AC voltage
 $\phi = 90^\circ$

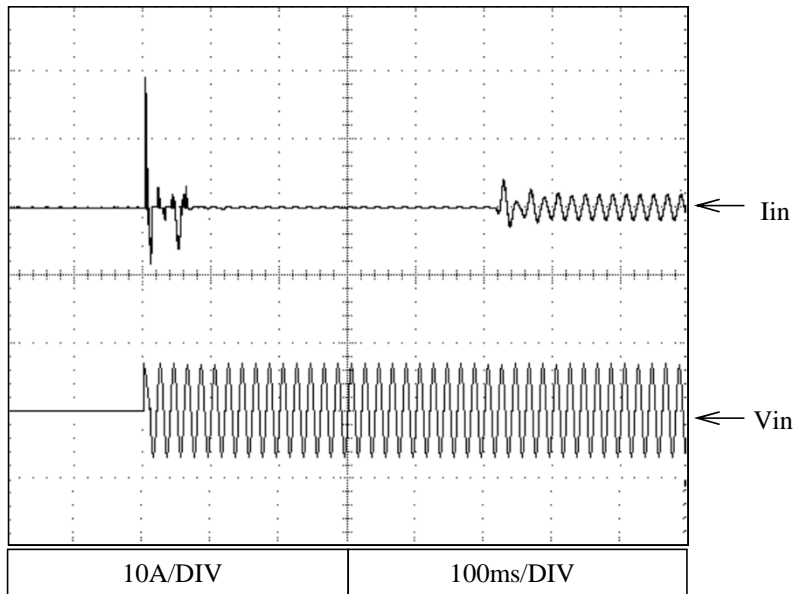

2.12 Input current waveform

24V

Conditions Vin : 100VAC
Iout : 100%
Ta : 25°C

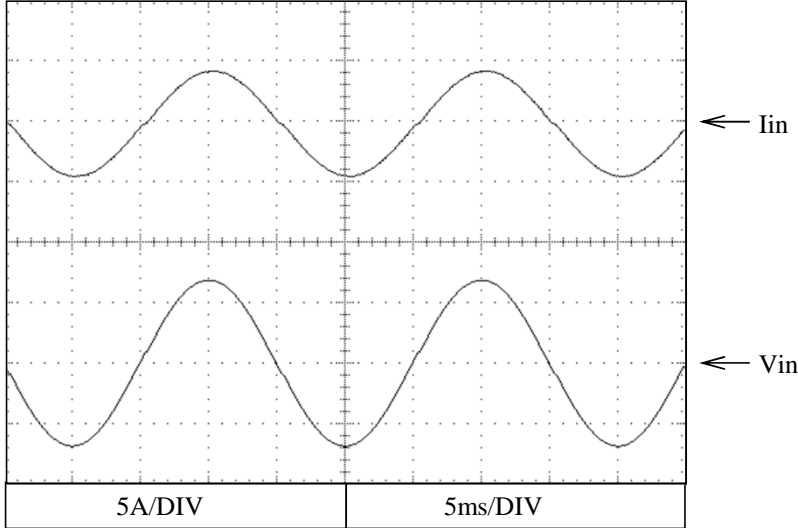

Conditions Vin : 230VAC
Iout : 100%
Ta : 25°C

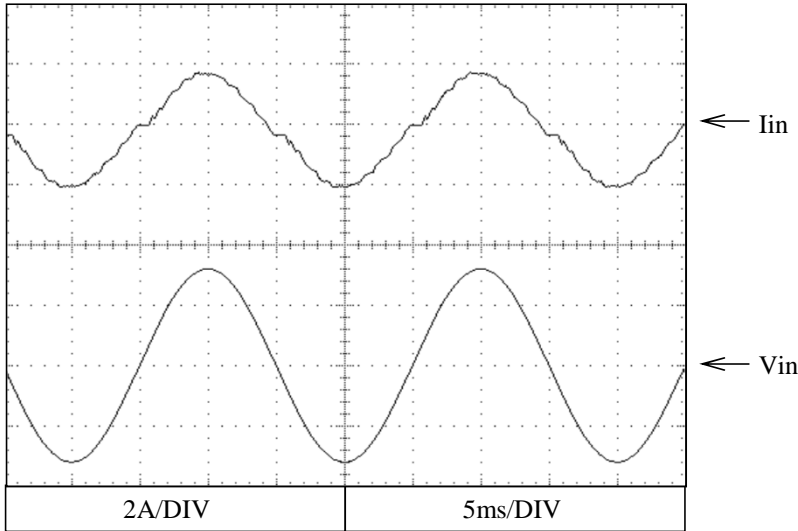

2.13 Input current harmonics

24V

Conditions Vin : 100VAC
Iout : 100%
Ta : 25°C

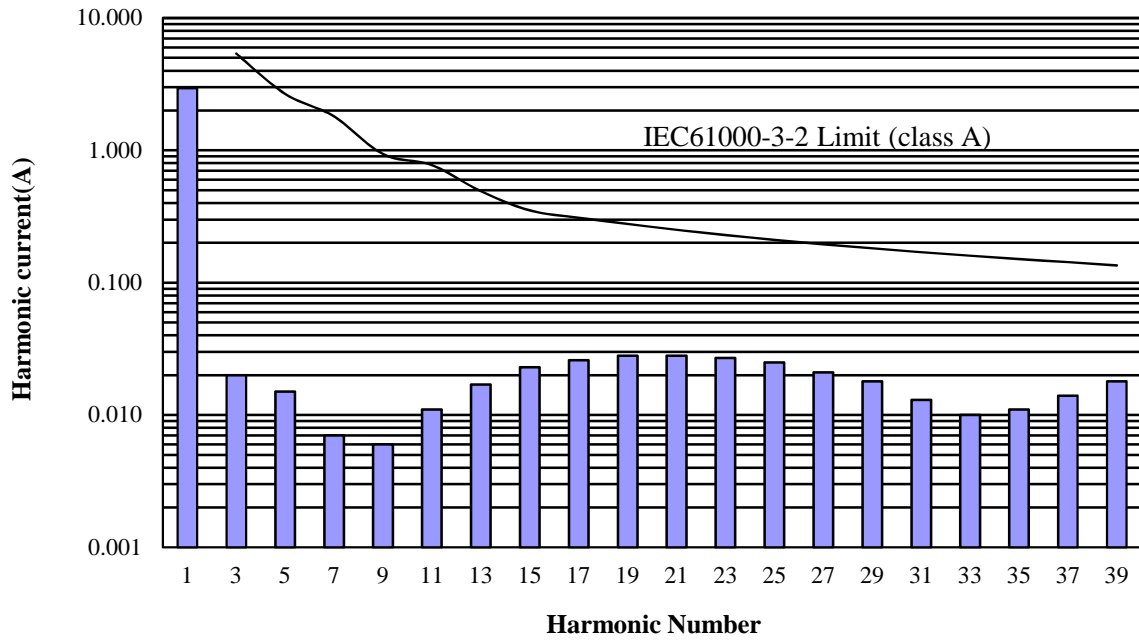

Conditions Vin : 230VAC
Iout : 100%
Ta : 25°C

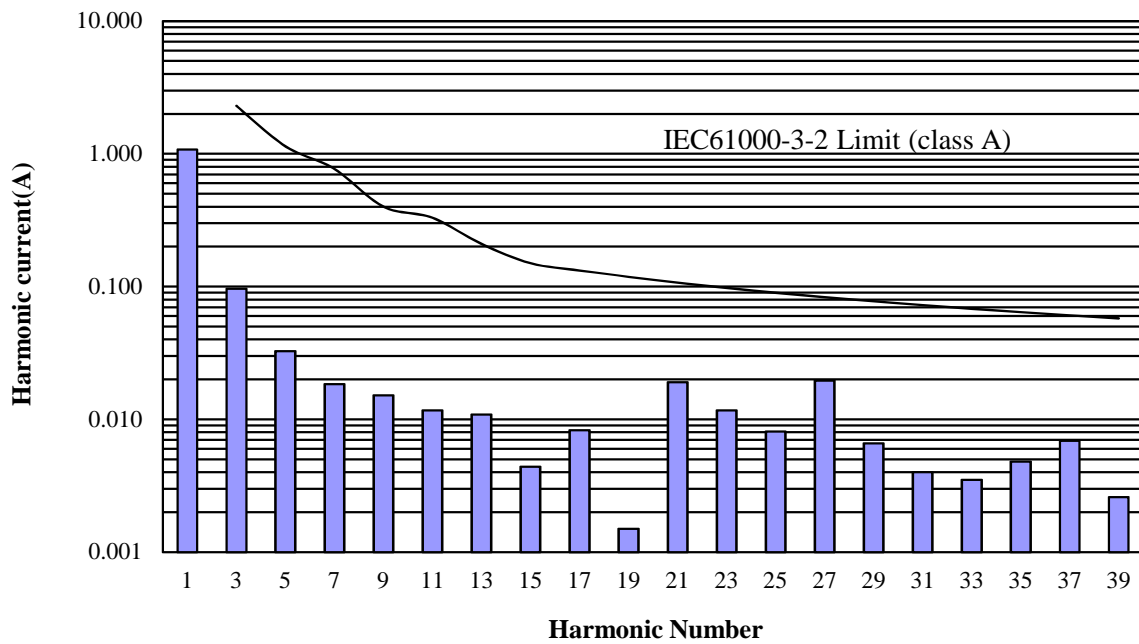

2.14 Leakage current characteristics

Conditions Iout : 0% -----
 : 100% —————
 Ta : 25°C
 f : 50Hz

24V

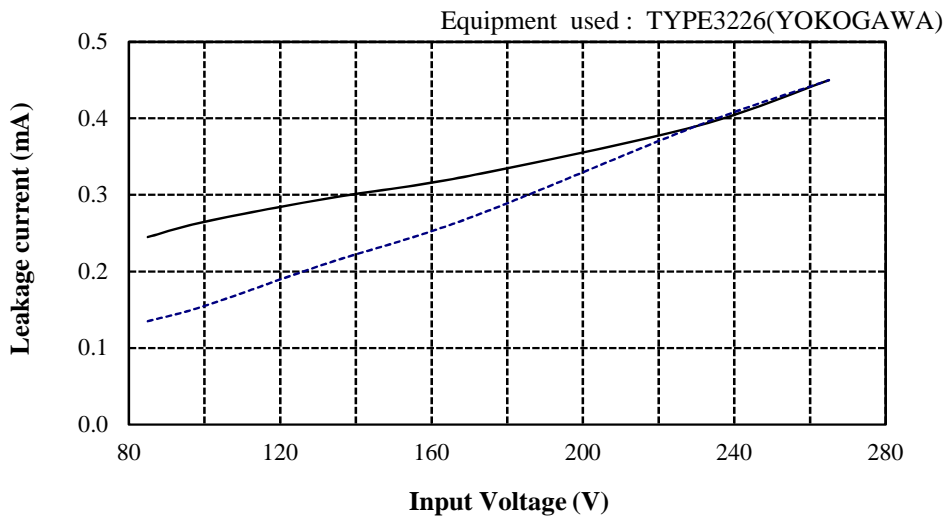
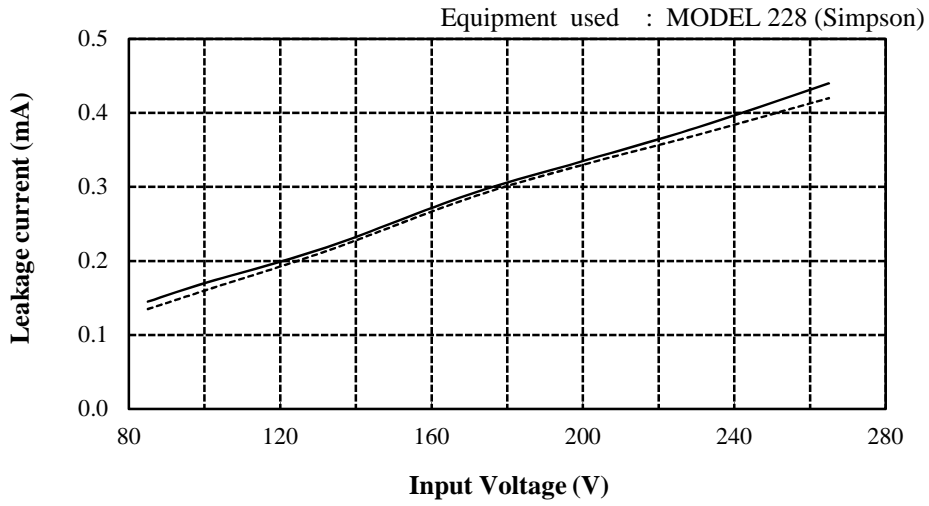

2.14 Output ripple and noise waveform

Conditions Vin : 100VAC
Iout : 100%
Ta : 25°C

NORMAL MODE

24V

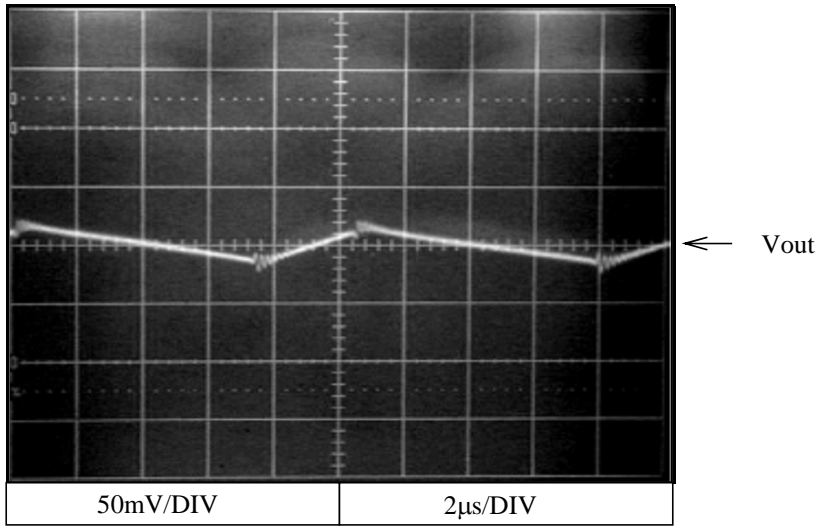

2.14 Output ripple and noise waveform

Conditions Vin : 100VAC
Iout : 100%
Ta : 25°C

NORMAL + COMMON MODE

24V

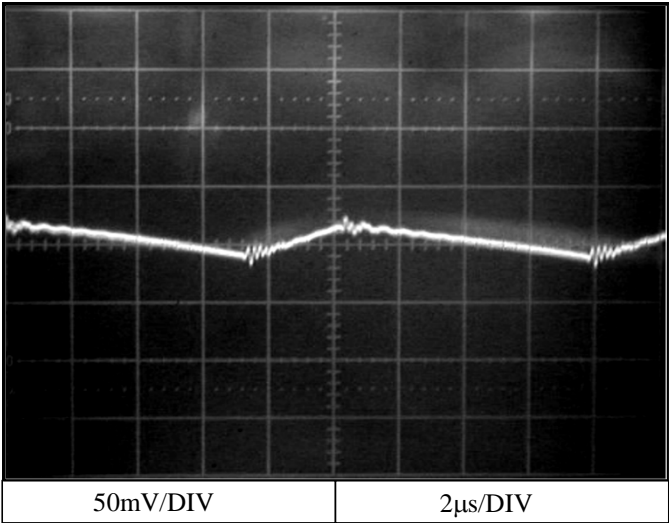

2.16 Stand-by current

Conditions Ta : 25°C

24V

Iout = 0%

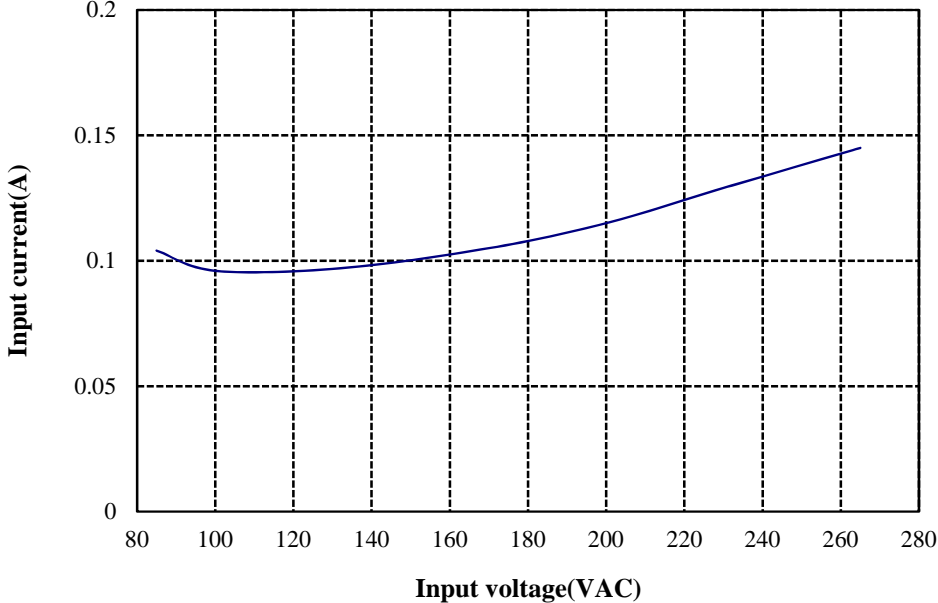

2.17 Hold up time characteristics

Conditions Vin : 100VAC -----
: 230VAC -----
Ta : 25°C

24V

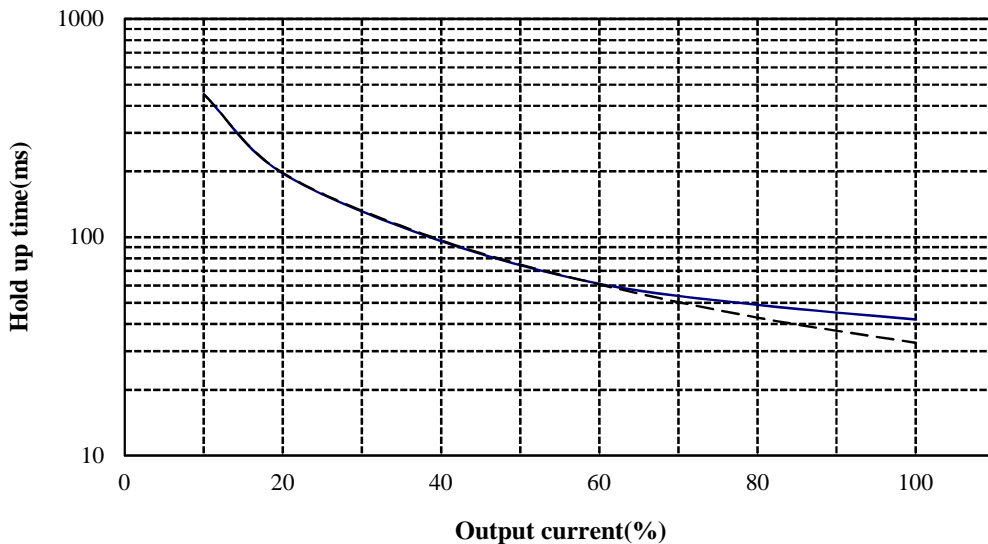

2.18 Electro-Magnetic Interference characteristics

Conducted Emission

24V

Conditions

Vin : 100VAC

Iout : 100%

Ref.	Point A (16.64MHz)	
	Data	Measure (dBuV)
QP	60.0	48.5
AV	50.0	41.3

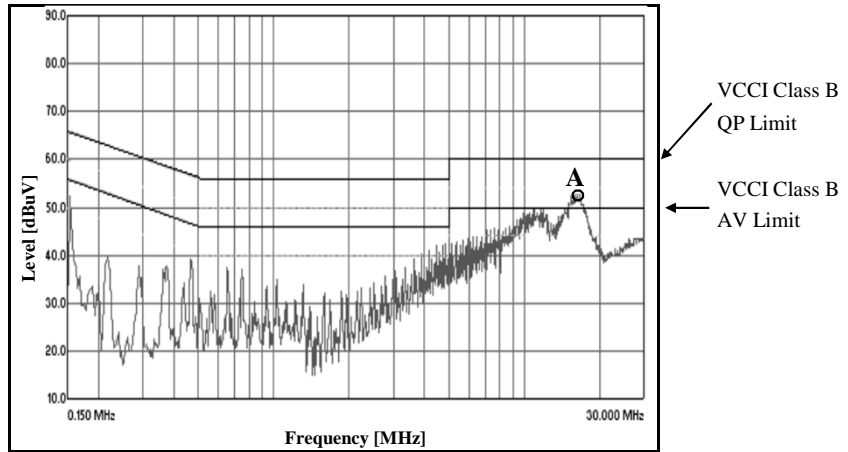

Phase : L

Ref.	Point B (16.67MHz)	
	Data	Measure (dBuV)
QP	60.0	43.2
AV	50.0	36.4

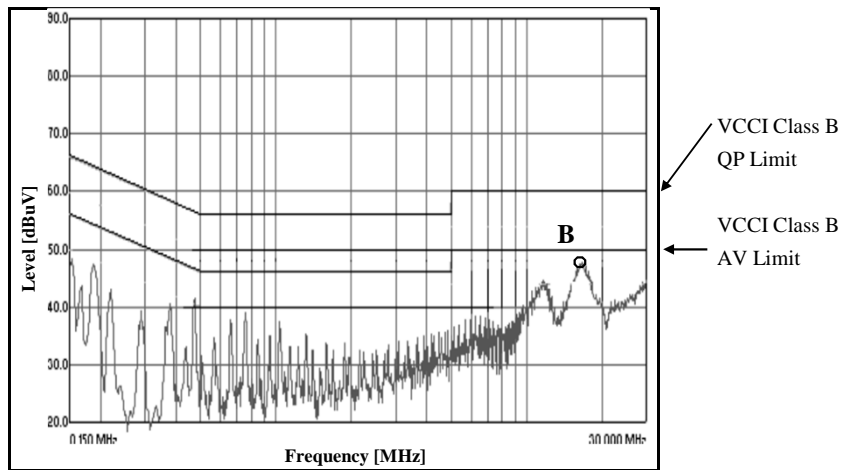

Phase : N

Limits of EN55032-B,FCC Class B are same as its VCCI class B.

2.18 Electro-Magnetic Interference characteristics

Conducted Emission

24V

Conditions

Vin : 230VAC

Iout : 100%

Ref.	Point A (16.45MHz)	
	Limit (dBuV)	Measure (dBuV)
QP	60.0	46.9
AV	50.0	40.9

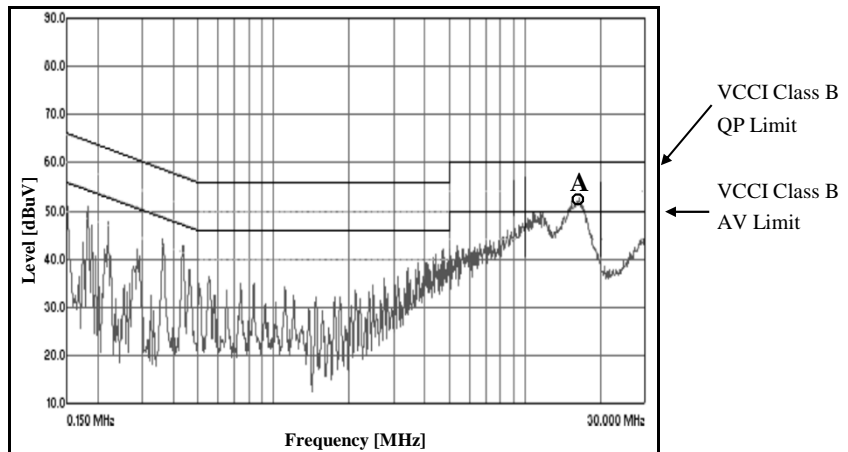

Phase : L

Ref.	Point B (16.24MHz)	
	Limit (dBuV)	Measure (dBuV)
QP	60.0	41.8
AV	50.0	36.1

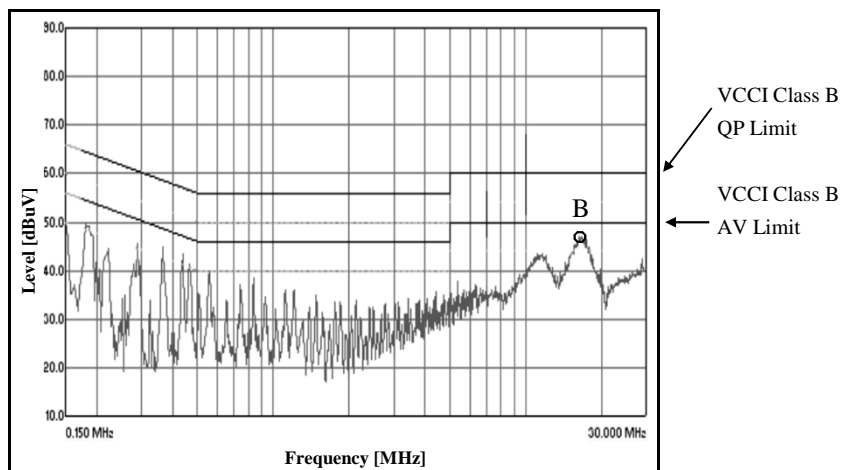

Phase : N

Limits of EN55032-B,FCC Class B are same as its VCCI class B.

2.18 Electro-Magnetic Interference characteristics

Radiated Emission

Conditions

Vin : 100VAC

Iout : 100%

24V
HORIZONTAL:

Point A (211.7MHz)	
Limit (dBuV/m)	Measure (dBuV/m)
40.0	37.8

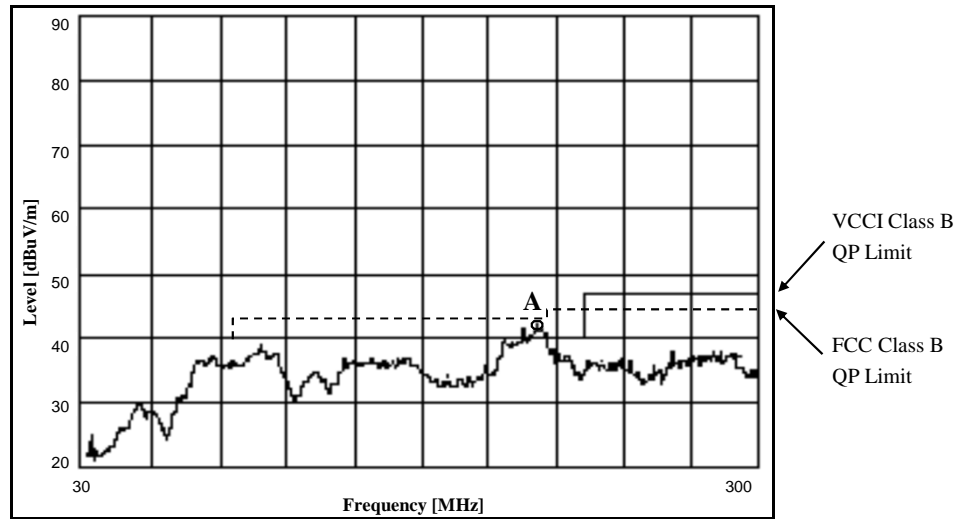

VERTICAL:

Point B (98.9MHz)	
Limit (dBuV/m)	Measure (dBuV/m)
40.0	38.6

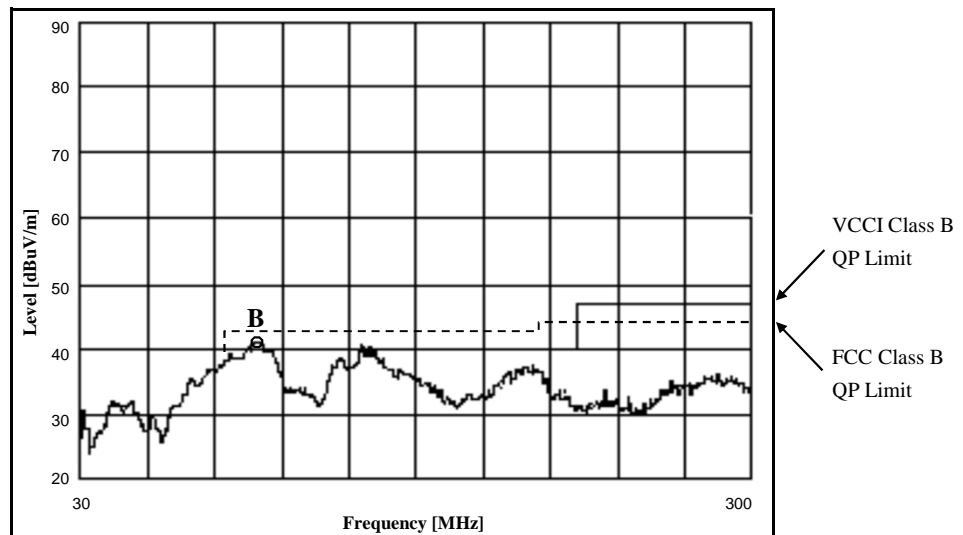

Limits of EN55032-B are same as its VCCI class B.

2.18 Electro-Magnetic Interference characteristics

Radiated Emission

Conditions

V_{in} : 230VAC

I_{out} : 100%

24V
HORIZONTAL:

Point A (208.3MHz)	
Limit (dBuV/m)	Measure (dBuV/m)
40.0	35.1

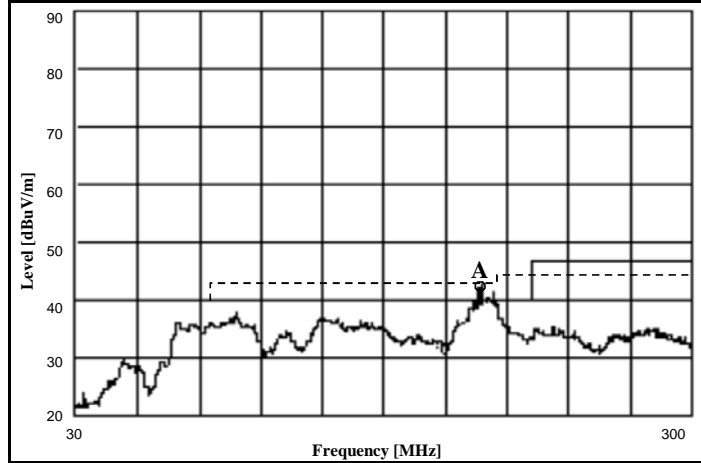

VERTICAL:

Point B (146.4MHz)	
Limit (dBuV/m)	Measure (dBuV/m)
40.0	34.7

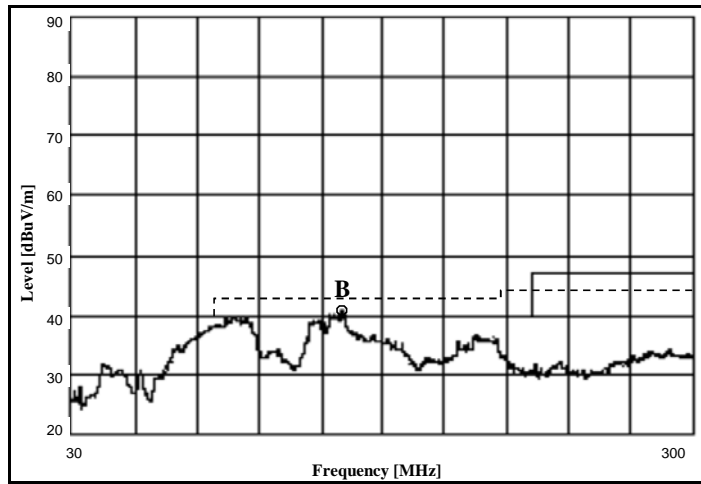

Limits of EN55032-B are same as its VCCI class B.