

DRB240-24-1

EVALUATION DATA

INDEX

1. Evaluation Method	PAGE
1.1 Circuit used for determination	
Circuit 1 used for determination	T-1
Steady state data	
Over current protection (OCP) characteristics	
Over voltage protection (OVP) characteristics	
Output rise characteristics	
Output fall characteristics	
Hold up time characteristics	
Response to brown out characteristics	
Input current harmonics	
Input current waveform	
Circuit 2 used for determination	T-1
Dynamic load response characteristics	
Circuit 3 used for determination	T-2
Inrush current waveform	
Circuit 4 used for determination.....	T-2
Leakage current characteristics	
Circuit 5 used for determination	T-2
Output ripple and noise waveform	
Configuration used for determination	T-3
Electro-Magnetic Interference characteristics	
(a) Conducted Emission	
(b) Radiated Emission	
1.2 List of equipment used	T-4

2. Characteristics

2.1	Steady state data	
(1)	Regulation - line and load, Temperature drift	
	/ Start up voltage and Drop out voltage	T-5
(2)	Efficiency vs. Output current	T-6
(3)	Input current vs. Output current	T-7
(4)	Input power vs. Output current	T-8
2.2	Over current protection (OCP) characteristics	T-9
2.3	Over voltage protection (OVP) characteristics	T-9
2.4	Output rise characteristics	T-10
2.5	Output fall characteristics	T-11
2.6	Hold up time characteristics	T-12
2.7	Dynamic load response characteristics	T-13
2.8	Response to brown out characteristics	T-14~15
2.9	Inrush current waveform	T-16
2.10	Input current harmonics	T-17
2.11	Input current waveform	T-17
2.12	Leakage current characteristics	T-18
2.13	Output ripple and noise waveform	T-19
2.14	Electro-Magnetic Interference characteristics	T-20~21

Terminology used

	Definition
V_{in} Input voltage
V_{out} Output voltage
I_{in} Input current
I_{out} Output current
T_a Ambient temperature
f Frequency

1. Evaluation Method

1.1 Circuit used for determination

Circuit 1 used for determination

- Steady state data
- Over current protection (OCP) characteristics
- Over voltage protection (OVP) characteristics
- Output rise characteristics
- Output fall characteristics
- Hold up time characteristics
- Response to brown out characteristics
- Input Current Harmonics
- Input current

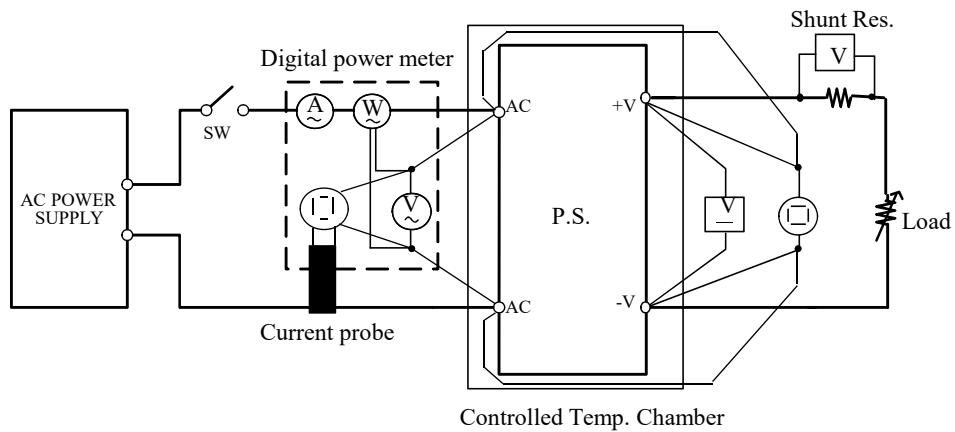

Circuit 2 used for determination

- Dynamic load response characteristics

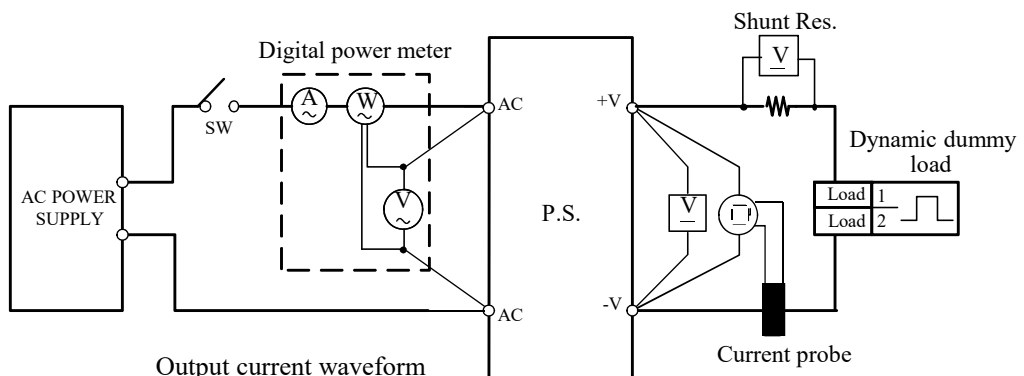

Output current waveform
I_{out} 25% <=> 75%

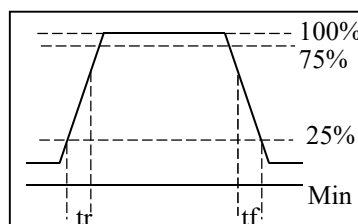

Circuit 3 used for determination

• Inrush current waveform

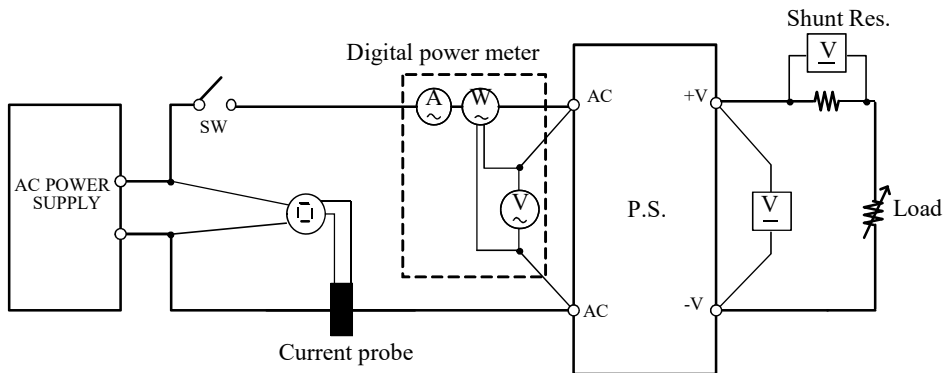

Circuit 4 used for determination

• Leakage current characteristics

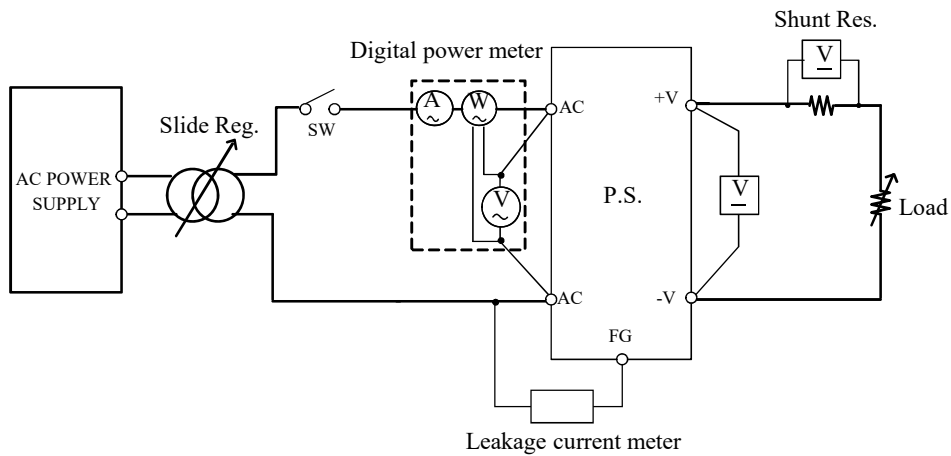

Circuit 5 used for determination

• Output ripple and noise waveform

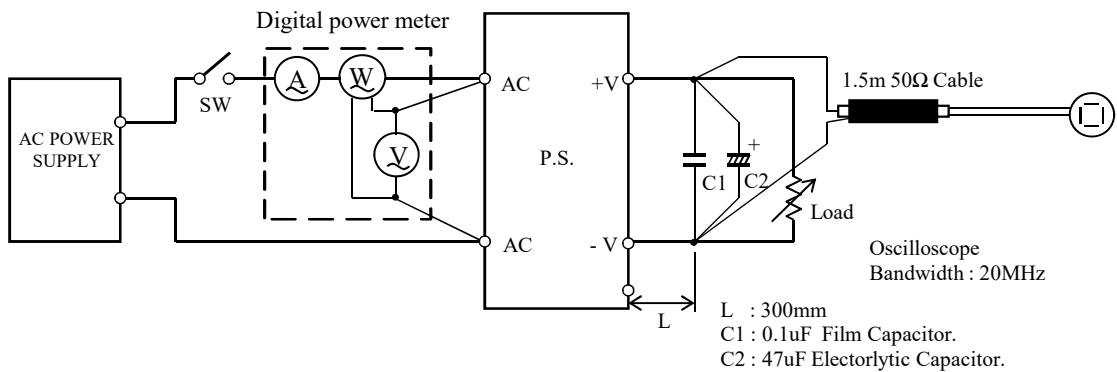

Configuration used for determination

- Electro-Magnetic Interference characteristics

(a) Conducted Emission

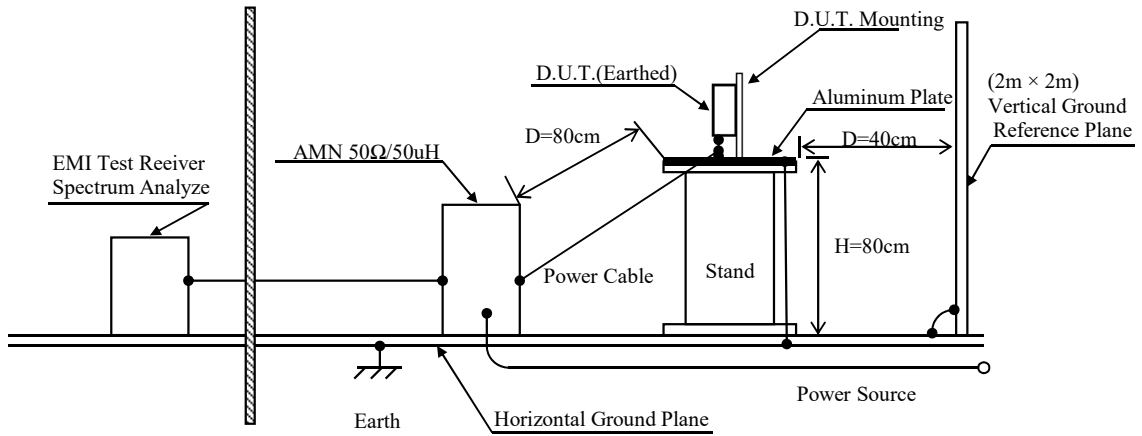

(b) Radiated Emission

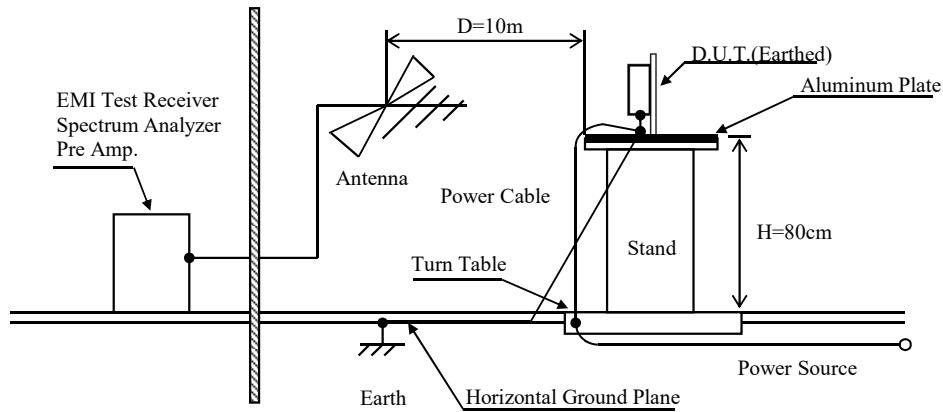

1.2 List of equipment used

	EQUIPMENT USED	MANUFACTURER	MODEL NO.
1	DIGITAL STORAGE OSCILLOSCOPE	YOKOGAWA	DL1740/DL1740E
2	DIGITAL MULTIMETER	AGILENT	34970A
3	DIGITAL POWER METER	HIOKI	3333
4	CURRENT PROBE/AMPLIFIER	YOKOGAWA	701931
5	DATA ACQUISITION UNIT	AGILENT	34970A
6	ELECTRONIC LOAD	CHROMA	63112A
7	CONTROLLED TEMP. CHAMBER	ESPEC	SH-641
8	LEAKAGE CURRENT METER	SIMPSON	228
9	AC SOURCE	CHROMA	61505
10	AC SOURCE (CE-UL Lab)	KEYSIGHT TECHNOLOGIES	6813B
11	EMI TEST RECEIVER (CE-UL Lab)	ROHDE & SCHWARZ	ES17
12	LISN (CE-UL Lab)	SCHAFFNER LISN	NNB 41
13	LISN (CE-UL Lab)	EMCO LISN (AE)	3825/2
14	EMI TEST RECEIVER (RE-UL Lab)	ROHDE & SCHWARZ 100Hz-26.5Ghz	ESU26
15	ANTENNA (BILOG) (RE-UL Lab)	TESEQ	CBL6112B
16	ANTENNA (HORN) (RE-UL Lab)	EMCO	3115
17	PRE AMP (RE-UL Lab)	HP	8447D
18	PRE AMP (RE-UL Lab)	TOYO	TPA0108-40

2 Characteristics

2.1 Steady state data

(1) Regulation - line and load, Temperature drift / Start up voltage and Drop out voltage

24V

1. Regulation - line and load

Condition Ta : 25°C

Iout \ Vin	85VAC	115VAC	230VAC	264VAC	line regulation	
0%	24.101	24.101	24.101	24.101	0mV	0.000%
50%	24.065	24.065	24.065	24.064	1mV	0.004%
100%	24.032	24.032	24.031	24.031	1mV	0.004%
load regulation	69mV	69mV	70mV	70mV		
	0.287%	0.287%	0.292%	0.292%		

2. Temperature drift

Condition Vin : 115VAC
Iout : 100%

Ta	-25°C	25°C	55°C	temperature stability	
Vout	23.951V	24.032V	24.042V	91mV	0.379%

3. Start up voltage and Drop out voltage

Condition Ta : 25°C
Iout : 100%

Start up voltage (Vin)	80VAC
Drop out voltage (Vin)	61VAC

(2) Efficiency vs. Output current

Conditions Vin : 85VAC -----
: 115VAC -.-.-.-
: 230VAC ————
: 264VAC - - - -
Ta : 25°C

24V

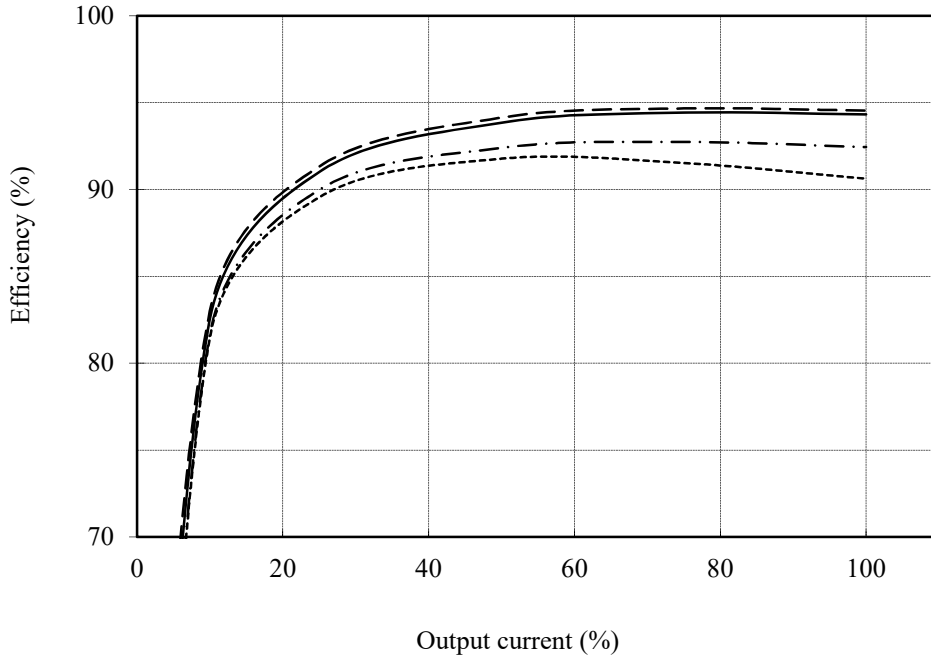

(3) Input current vs. Output current

Conditions Vin : 85VAC -----
 : 115VAC -.-.-.-
 : 230VAC ————
 : 264VAC - - - -
 Ta : 25°C

24V

Vin	Input current
	Iout : 0%
85VAC	0.071A
115VAC	0.081A
230VAC	0.014A
264VAC	0.016A

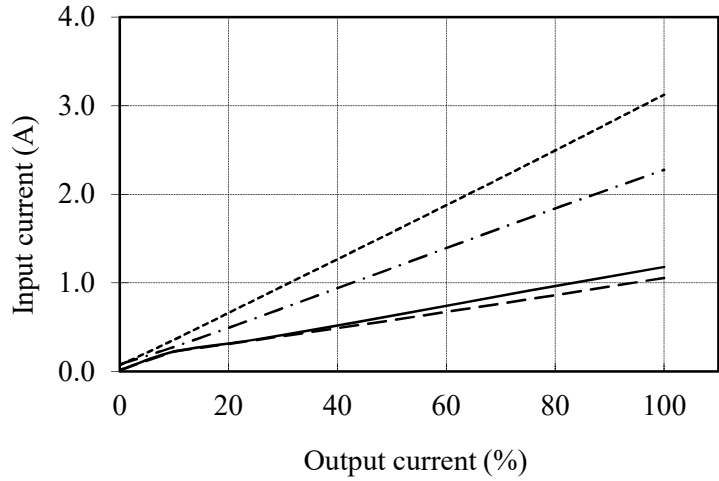

DRB240-24-1

(4) Input power vs. Output current

Conditions Vin: 85VAC -----
: 115VAC -.-.-.-
: 230VAC ————
: 264VAC - - - -
Ta: 25°C

24V

Vin	Input power
	Iout : 0%
85VAC	1.68W
115VAC	1.64W
230VAC	1.60W
264VAC	1.58W

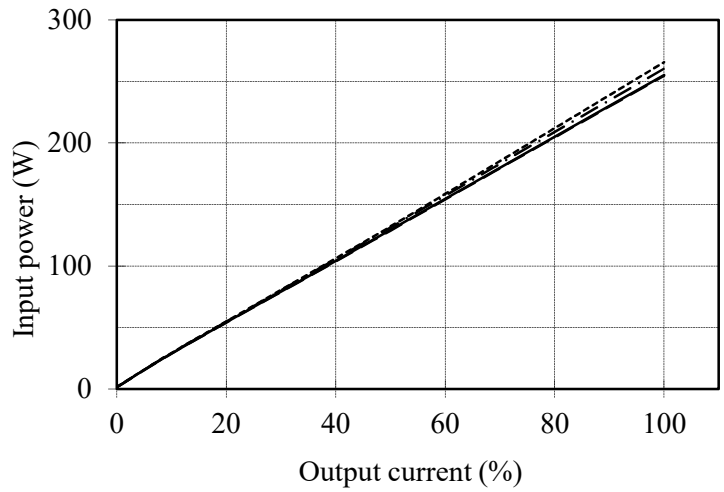

2.2 Over current protection (OCP) characteristics 2.3 Over voltage protection (OVP) characteristics

Conditions Vin : 115VAC
 Ta : -25°C -----
 25°C -.-.-.-
 55°C _____

Conditions Vin : 115VAC
 Iout : 0%
 Ta : 25°C

24V

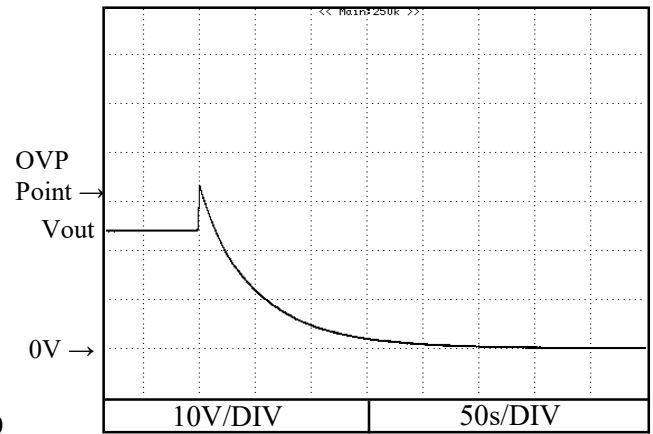
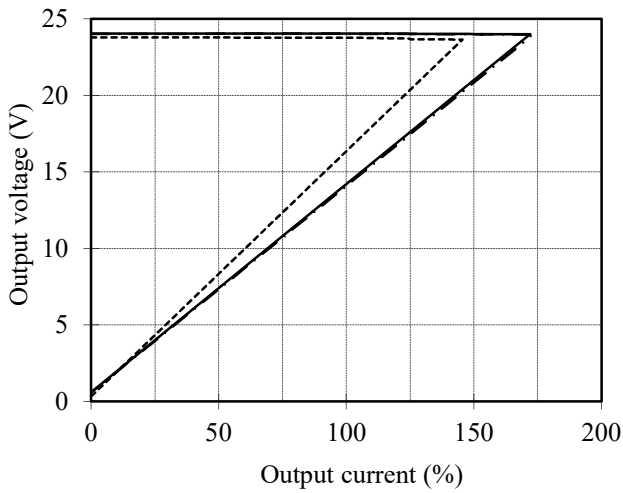

2.4 Output rise characteristics

Conditions Vin: 85VAC (A)
: 115VAC (B)
: 230VAC (C)
: 264VAC (D)
Ta: 25°C

24V

Iout : 0%

Iout : 100%

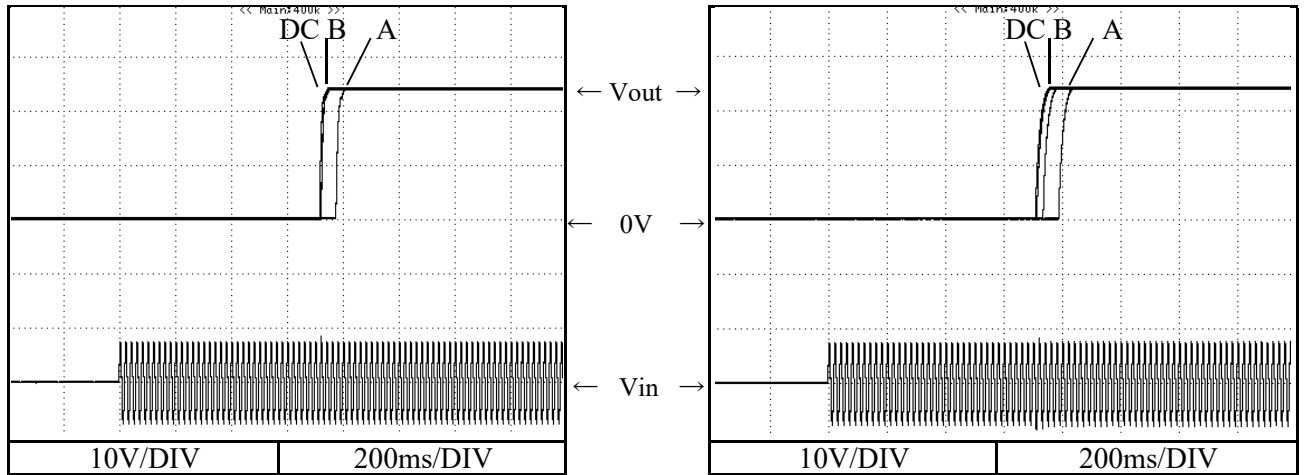

2.5 Output fall characteristics

Conditions Vin: 85VAC (A)
 : 115VAC (B)
 : 230VAC (C)
 : 264VAC (D)
 Ta: 25°C

24V

Iout : 0%

Iout : 100%

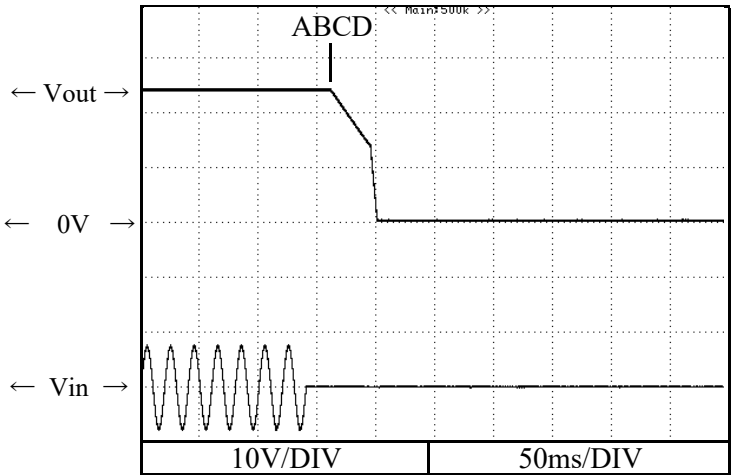
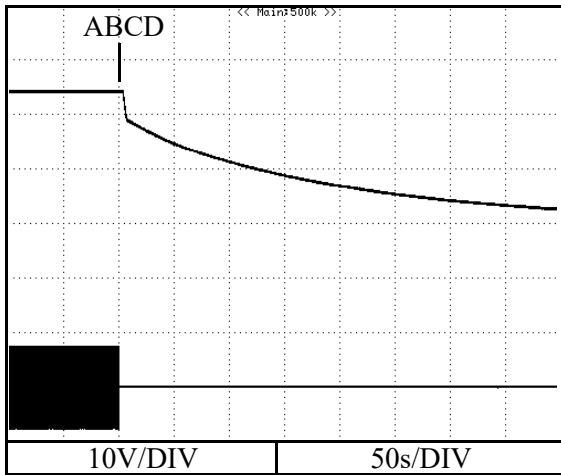

2.6 Hold up time characteristics

Conditions Vin : 115VAC -----
 230VAC —
 Ta : 25°C

24V

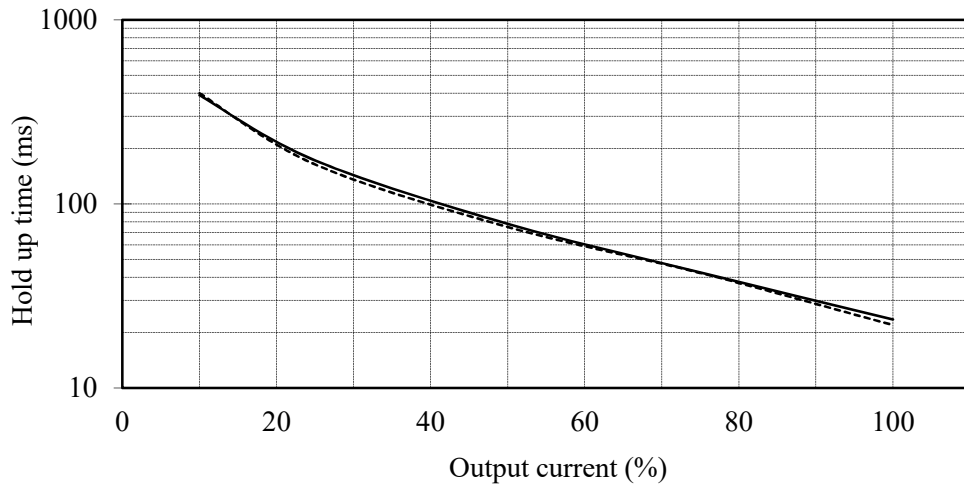

2.7 Dynamic load response characteristics

Conditions Vin : 115VAC
 Iout : 25% ↔ 75%
 (tr = tf = 50us)
 Ta : 25°C

24V

f = 100Hz

f = 1kHz

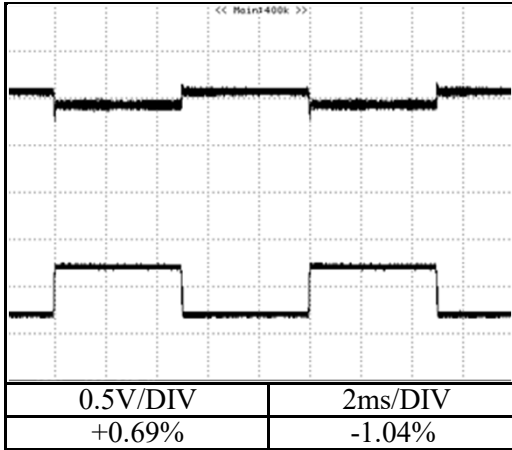

← Vout →
 ← Iout →
 ← Iout:0% →

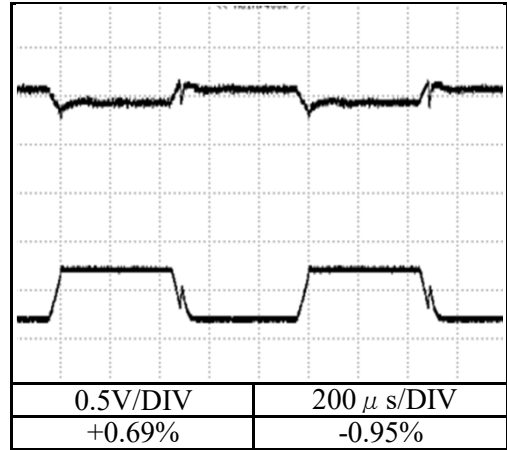

2.8 Response to brown out characteristics

Conditions Vin : 115VAC
Iout : 100%
Ta : 25°C

24V

A = 23ms
B = 34ms
C = 35ms

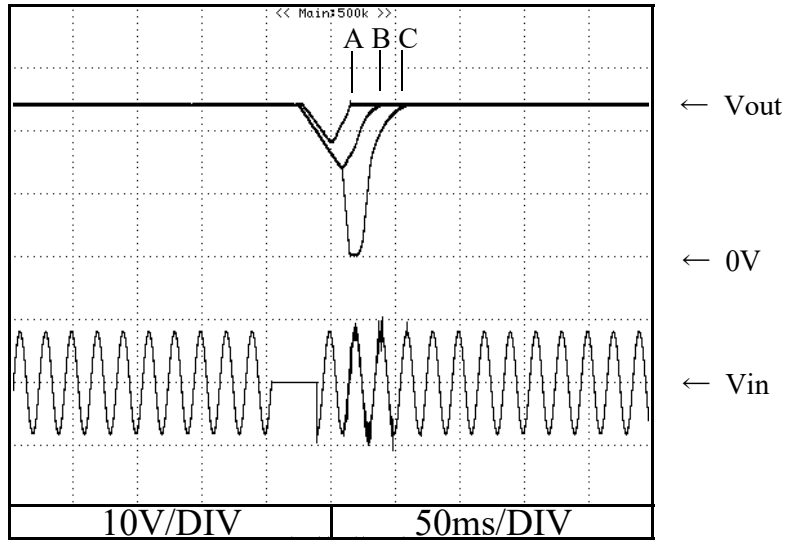

2.8 Response to brown out characteristics

Conditions Vin : 230VAC
Iout : 100%
Ta : 25°C

24V

A = 27ms
B = 54ms
C = 55ms

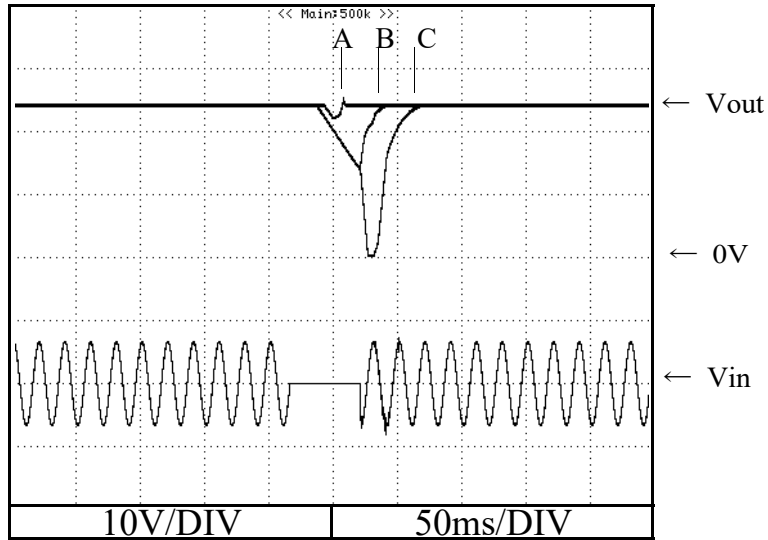

2.9 Inrush current waveform

24V

Conditions V_{in} : 115VAC
 I_{out} : 100%
 T_a : 25°C

Switch on phase angle of input AC voltage
 $\phi = 0^\circ$

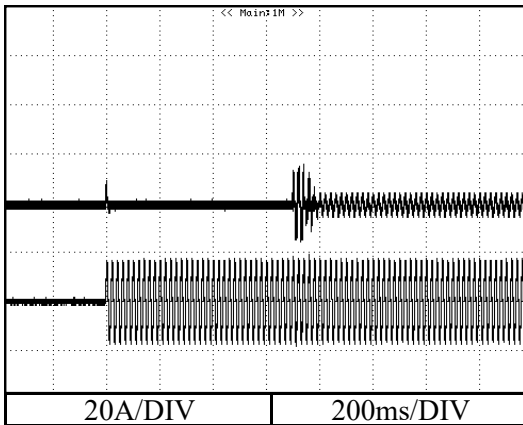

Switch on phase angle of input AC voltage
 $\phi = 90^\circ$

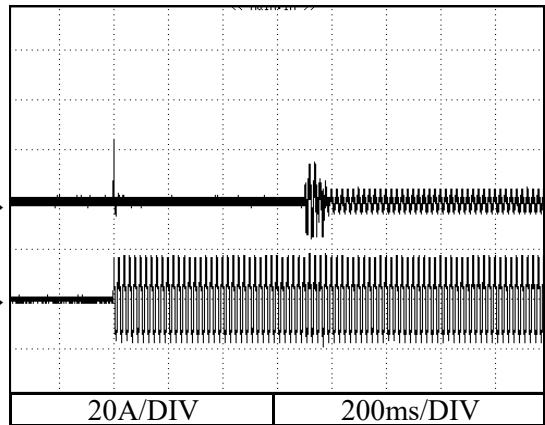

Conditions V_{in} : 230VAC
 I_{out} : 100%
 T_a : 25°C

Switch on phase angle of input AC voltage
 $\phi = 0^\circ$

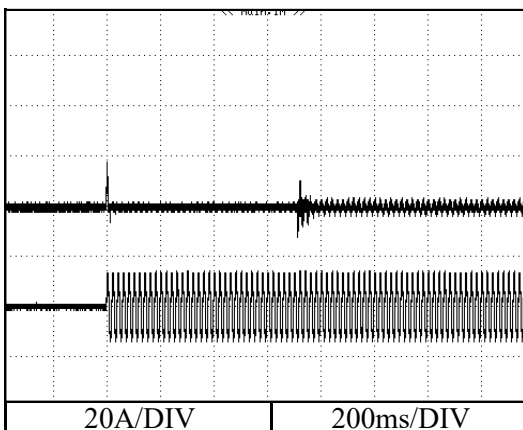

Switch on phase angle of input AC voltage
 $\phi = 90^\circ$

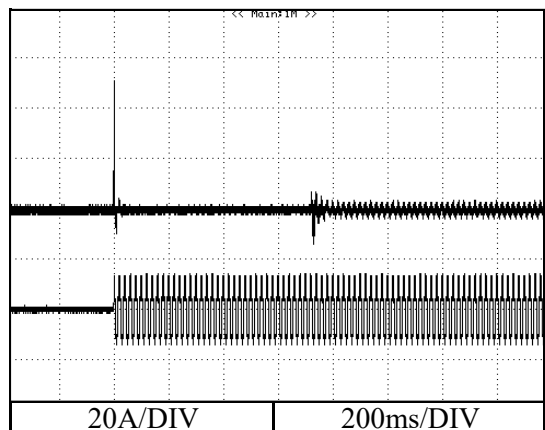

2.10 Input current harmonics

Conditions Iout : 100%
Ta : 25°C

24V

Vin : 115VAC

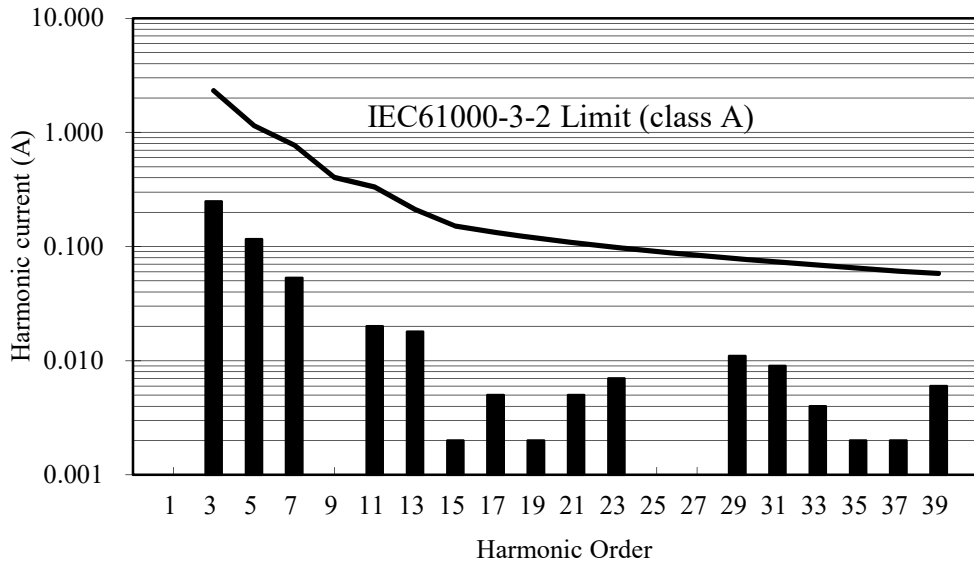

2.11 Input current waveform

Conditions Iout : 100%
Ta : 25°C

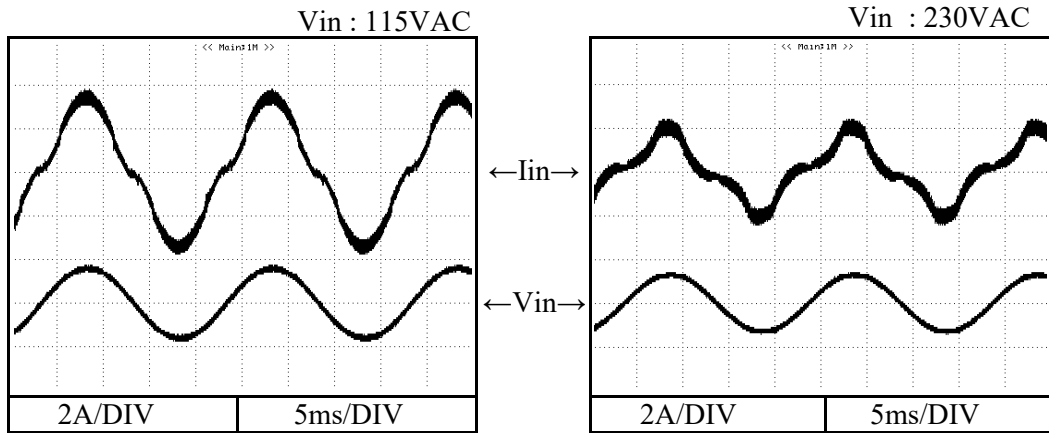

2.12 Leakage current characteristics

Conditions Iout : 0% -----
100% ———
Ta : 25°C

24V

f : 50Hz

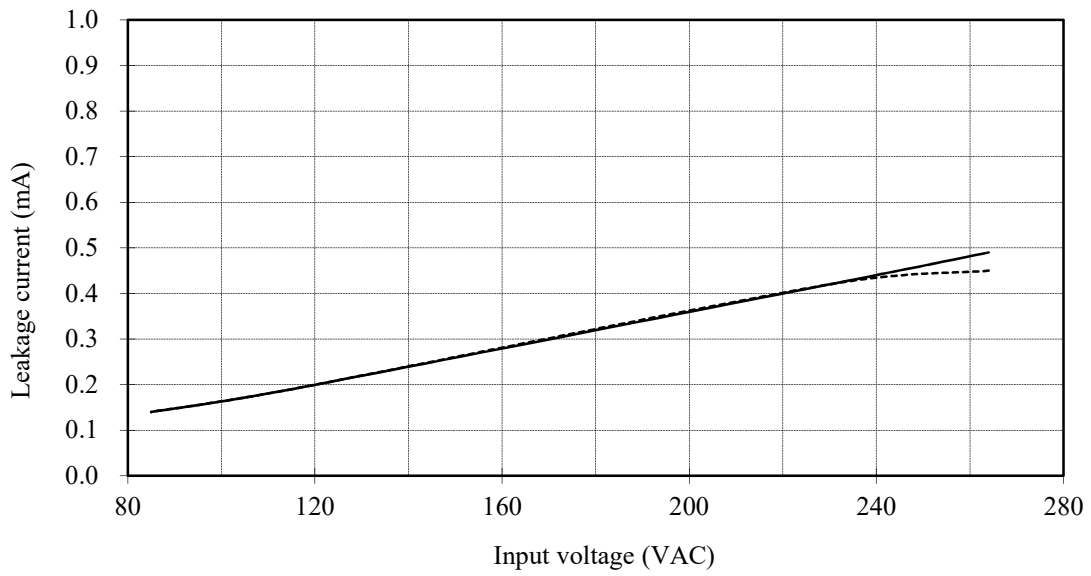

f : 60Hz

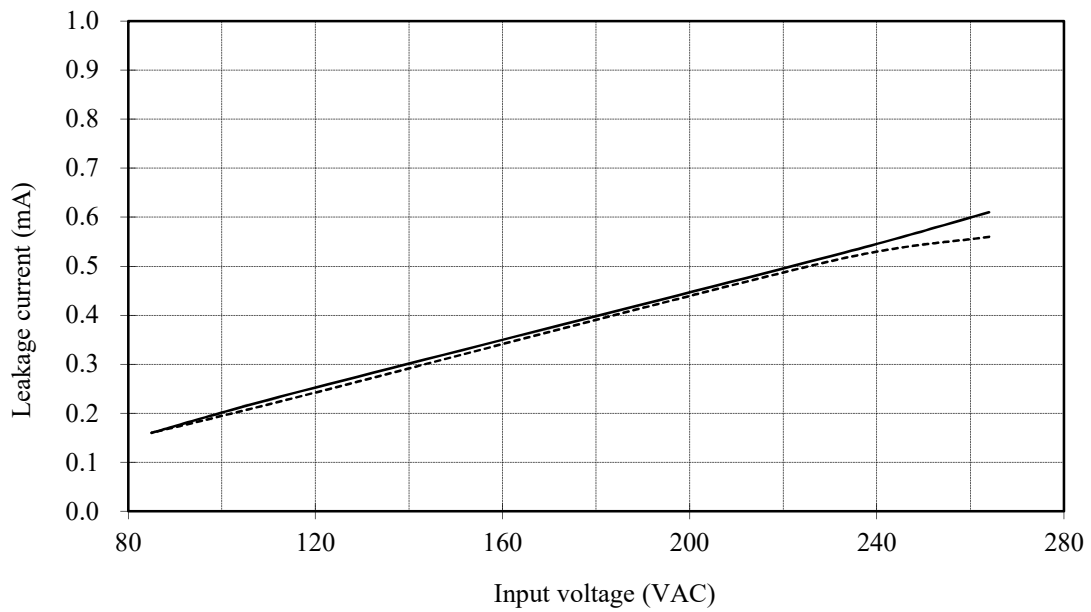

2.13 Output ripple and noise waveform

Conditions Vin : 115VAC
Iout : 0%
Ta : 25°C

24V

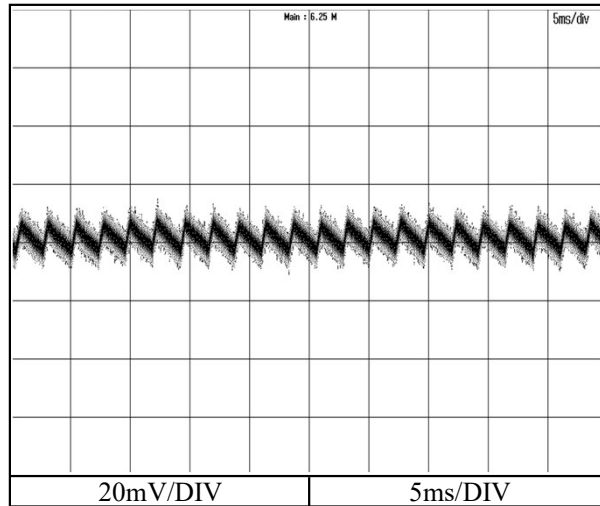

Conditions Vin : 115VAC
Iout : 100%
Ta : 25°C

24V

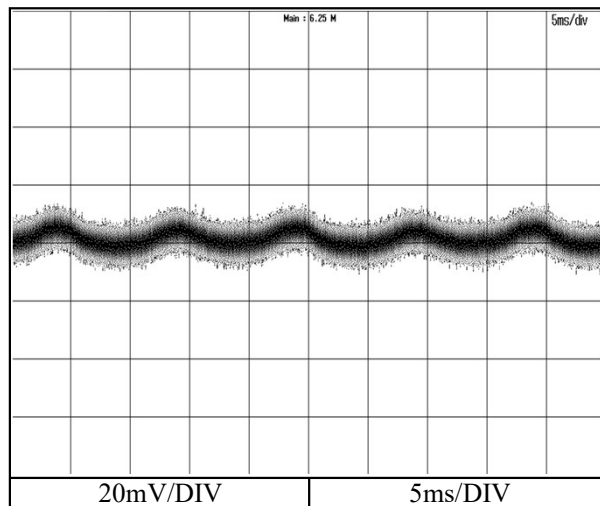

2.14 Electro-Magnetic Interference characteristics

Conditions Vin : 230VAC
 Iout : 100%
 Ta : 25°C
 QP Limit : — (red line)
 AVE Limit : — (blue line)

Conducted Emission

24V

LIVE

Point A (0.258MHz)		
Ref. Data	Limit (dBuV)	Measure (dBuV)
QP	61.5	54.8
AV	51.5	41.5

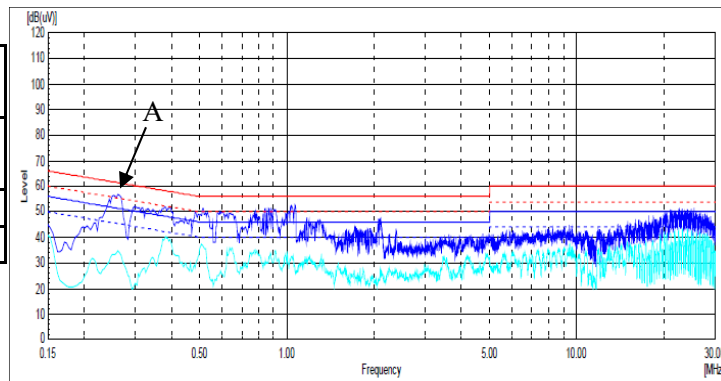

EN55032-B
QP Limit
 EN55032-B
AV Limit

NEUTRAL

Point B (1.168MHz)		
Ref. Data	Limit (dBuV)	Measure (dBuV)
QP	56	49.2
AV	46	32.6

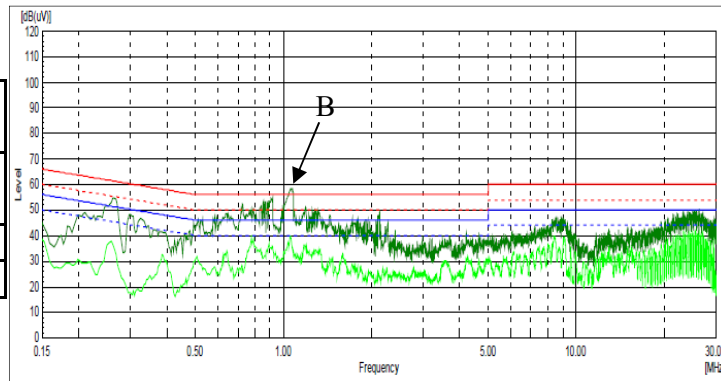

EN55032-B
QP Limit
 EN55032-B
AV Limit

2.15 Electro-Magnetic Interference characteristics

Conditions V_{in} : 230VAC
 I_{out} : 100%
 T_a : 25°C
 Horizontal : — (orange)
 Vertical : — (blue)

Radiated Emission

24V

Point A (274.78MHz)		
Ref. Data	Limit (dBuV)	Measure (dBuV)
QP	37.0	27.0

