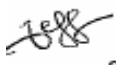
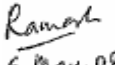
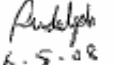

LS100

EVALUATION DATA

DWG.No PA577-53-01		
APPD	CHK	DWG
 6 May 08	 6 May 08	 6-5-08

DENSEI-LAMBDA

INDEX

1. Evaluation Method	PAGE
1-1 Circuit used for determination	T-1~5
(1) Steady state data	
(2) Warm up voltage drift characteristics	
(3) Over current protection (OCP) characteristics	
(4) Over voltage protection (OVP) characteristics	
(5) Output rise characteristics	
(6) Output fall characteristics	
(7) Response to brown out characteristics	
(8) Dynamic line response characteristics	
(9) Dynamic load response characteristics	
(10) Inrush current characteristics	
(11) Leakage current characteristics	
(12) Output ripple and noise waveform	
(13) Electro-Magnetic Interference characteristics	
1-2 List of equipment used	T-6
2. Characteristics	
2-1 Steady state data	
(1) Regulation - line and load, temperature drift	T-7
(2) Output voltage and Ripple voltage vs. input voltage	T-8
(3) Efficiency and Input current vs. Output current	T-9
2-2 Warm up voltage drift characteristics	T-10
2-3 Over current protection (OCP) characteristics	T-11
2-4 Over voltage protection (OVP) characteristics	T-14
2-5 Output rise characteristics	T-15
2-6 Output fall characteristics	T-17
2-7 Hold up time characteristics	T-19
2-8 Dynamic line response characteristics	T-20
2-9 Dynamic load response characteristics	T-21
2-10 Response to brown out characteristics	T-27
2-11 Inrush current waveform	T-29
2-12 Input current harmonics	T-31
2-13 Leakage current characteristics	T-32
2-14 Output ripple and noise waveform	T-33
2-15 Electro-Magnetic Interference characteristics	T-35

Terminology Used

	Definition
Vin Input voltage
Vout Output Voltage
Iin Input Current
Iout Output Current
Ta Ambient temperature

1. Evaluation Method

1-1 Circuit used for determination

(1) Steady state data

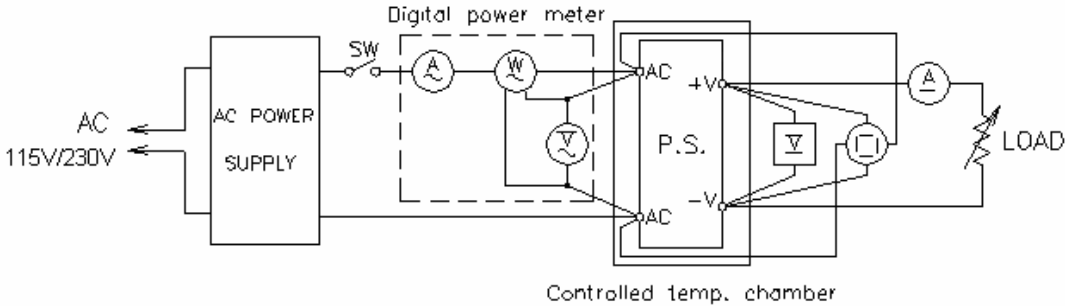

(2) Warm up voltage drift characteristics
Same as Steady state data

(3) Over current protection (OCP) characteristics

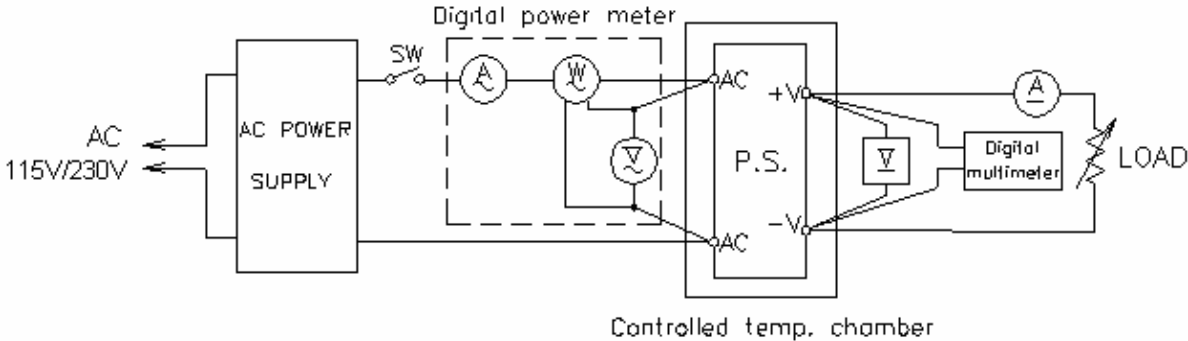

(4) Over voltage protection (OVP) characteristics
Same as Steady state data

(5) Output rise characteristics

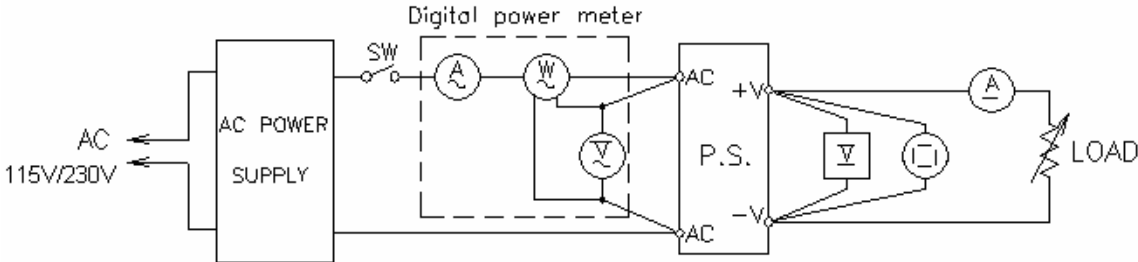

- (6) Output fall characteristics
Same as Output rise characteristics
- (7) Response to brown out characteristics

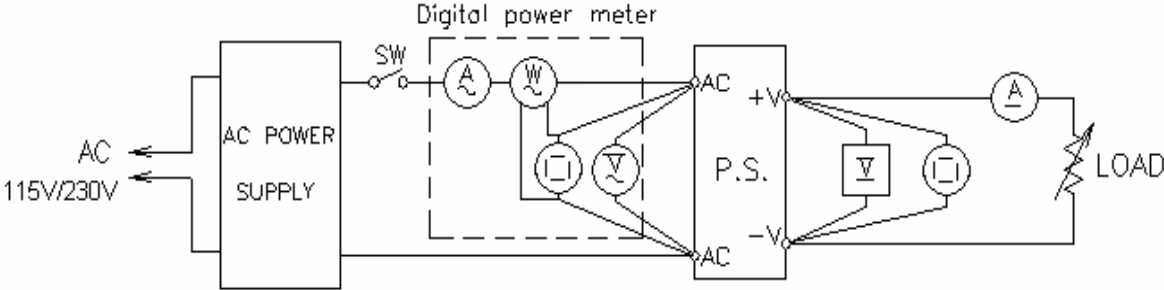

- (8) Dynamic line characteristics
Same as Response to brown out characteristics.

- (9) Dynamic load response characteristics

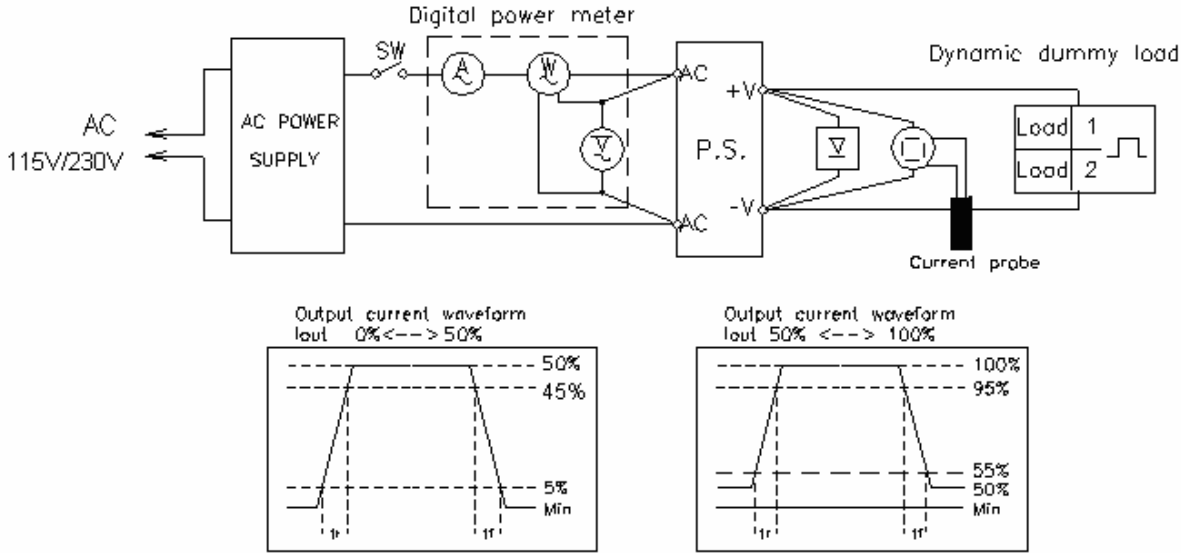

(10) Inrush current characteristics

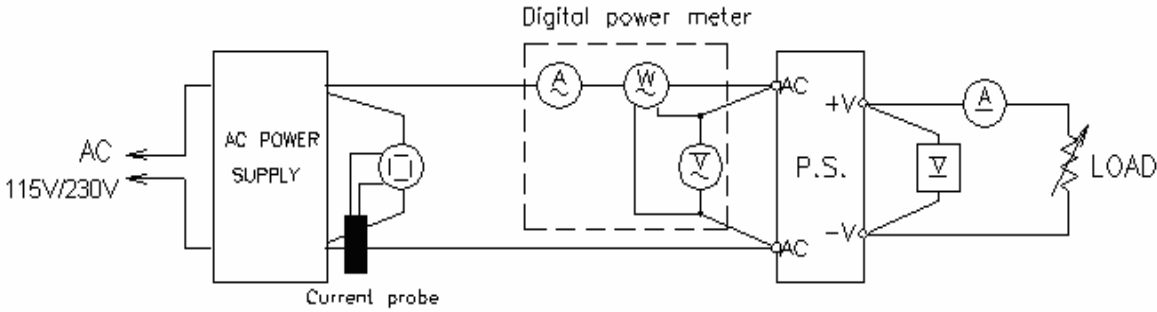

(11) Leakage current characteristics

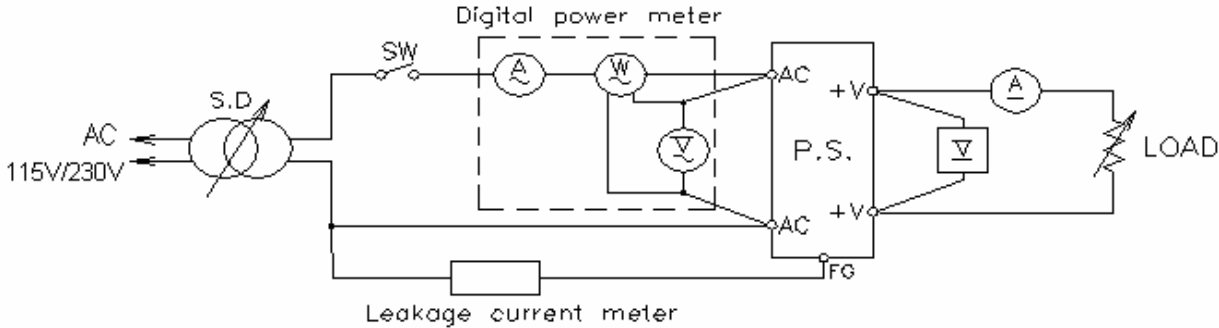

Range used---AC (For SIMPSON TYPE 228)

(12) Output ripple and noise waveform

(a) Normal Mode (using a 12" twisted pair terminated with 0.1uF and 47uF capacitor at 20MHz)

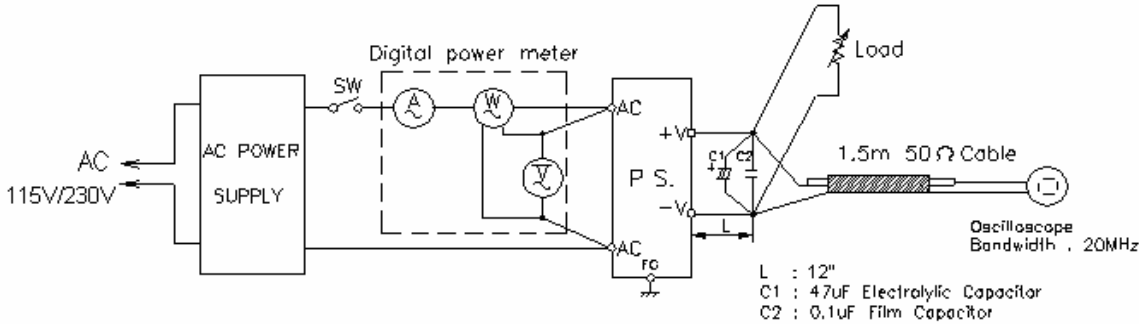

(b) Normal +Common Mode

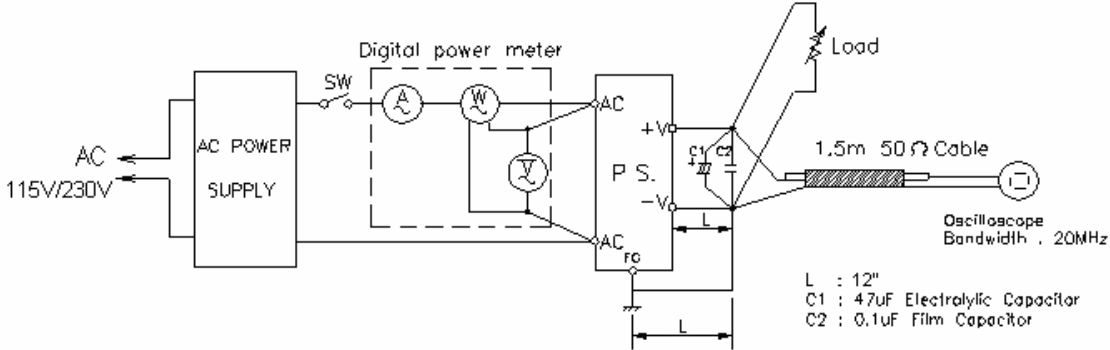

(13) Electro-Magnetic Interference characteristics

(a) Conducted Emission Noise

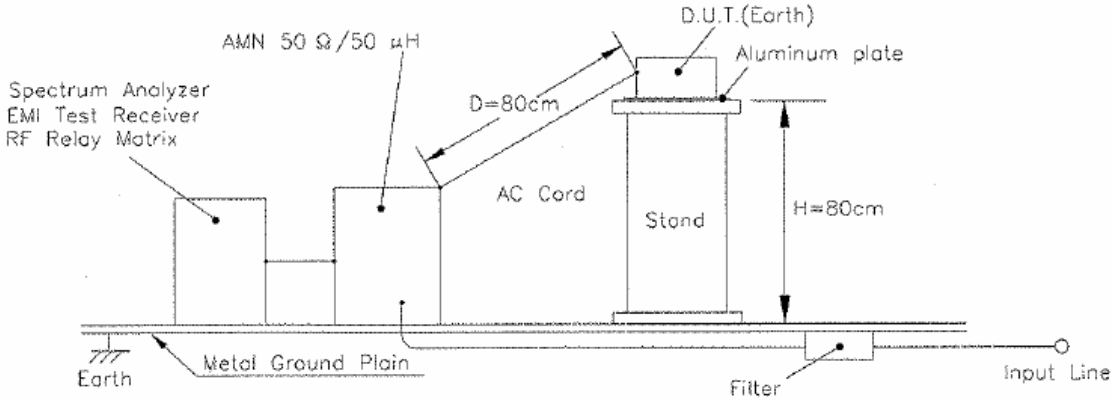

(b) Radiated Emission Noise

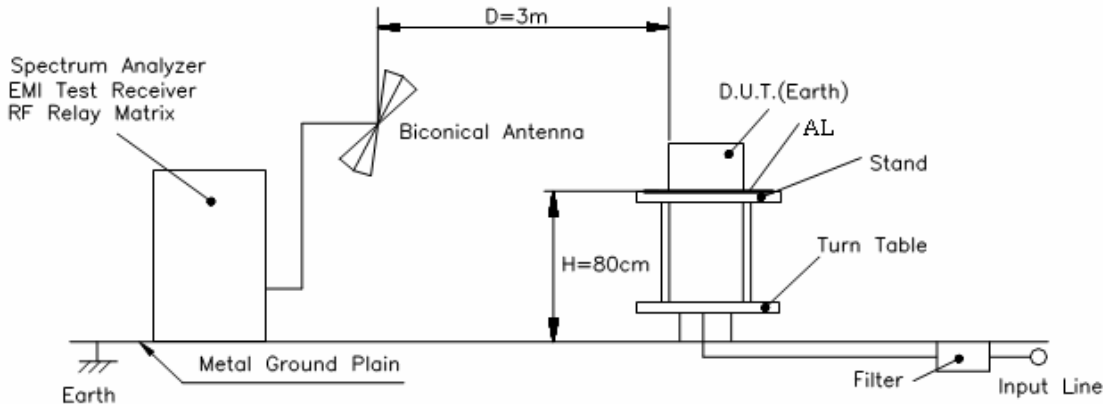

1-2 List of equipment used

	EQUIPMENT USED	MANUFACTURER	MODEL NO.
1	DIGITAL STORAGE OSCILLOSCOPE	YOKOGAWA	DL1740/DL1740E
2	DIGITAL MULTIMETER	FLUKE	89 VI
3	DIGITAL POWER METER	YOKOGAWA	WT210
4	CURRENT PROBE/AMPLIFIER	TEKTRONIX	TCP404XL/TCPA400
5	DYNAMIC DUMMY LOAD	CHROMA	63030/63201
6	DYNAMIC DUMMY LOAD	KIKUSUI	PLZ1004W
7	CONTROLLED TEMP. CHAMBER	ESPEC	SU-241
8	LEAKAGE CURRENT METER	SIMPSON	228
9	AC SOURCE	KIKUSUI	PCR-2000L
10	AC SOURCE	CHROMA	6530
11	POWER ANALYZER	CHROMA	6630
12	EMI TEST RECEIVER	ROHDE&SCHWARZ	ESCI
13	EMI TEST RECEIVER	ROHDE&SCHWARZ	ESI26
14	LISN	ROHDE&SCHWARZ	ENV216
15	ANTENNA	ROHDE&SCHWARZ	HL562

2. Characteristics

2-1 Steady state data

(1) Regulation - line and load, Temperature drift

5V

1. Regulation-line and load Condition Ta : 25°C

Iout \ Vin	88VAC	115VAC	230VAC	264VAC	line regulation	
0%	5.011	5.011	5.011	5.011	0.000V	0.000%
50%	5.005	5.005	5.006	5.006	0.001V	0.020%
100%	5.000	5.000	5.000	5.000	0.000V	0.000%
load regulation	0.011V	0.011V	0.011V	0.011V		
	0.220%	0.220%	0.220%	0.220%		

2. Temperature drift Conditions Vin = 115VAC
Iout = 100%

Ta	-25°C	25°C	45°C	temperature stability	
Vout	4.997V	5.000V	5.002V	0.005V	0.10%

12V

1. Regulation-line and load Condition Ta : 25°C

Iout \ Vin	88VAC	115VAC	230VAC	264VAC	line regulation	
0%	12.003	12.001	12.001	12.016	0.015V	0.125%
50%	11.996	11.996	11.995	11.994	0.002V	0.017%
100%	11.991	11.991	11.990	11.989	0.002V	0.017%
load regulation	0.012V	0.010V	0.011V	0.027V		
	0.100%	0.083%	0.092%	0.225%		

2. Temperature drift Conditions Vin = 115VAC
Iout = 100%

Ta	-25°C	25°C	50°C	temperature stability	
Vout	12.032V	11.991V	11.982V	0.050V	0.42%

24V

1. Regulation-line and load Condition Ta : 25°C

Iout \ Vin	88VAC	115VAC	230VAC	264VAC	line regulation	
0%	24.000	24.000	23.999	23.999	0.001V	0.004%
50%	23.994	23.994	23.992	23.990	0.004V	0.017%
100%	23.988	23.988	23.987	23.986	0.002V	0.008%
load regulation	0.012V	0.012V	0.012V	0.013V		
	0.050%	0.050%	0.050%	0.054%		

2. Temperature drift Conditions Vin = 115VAC
Iout = 100%

Ta	-25°C	25°C	50°C	temperature stability	
Vout	24.025V	23.988V	23.954V	0.071V	0.296%

2-1 Steady State Data

(2) Output Voltage And Ripple Voltage Vs Input Voltage

Condition : Iout = 100%
 Ta = -25°C
 = 25°C - - -
 = 50°C - . - .

5V

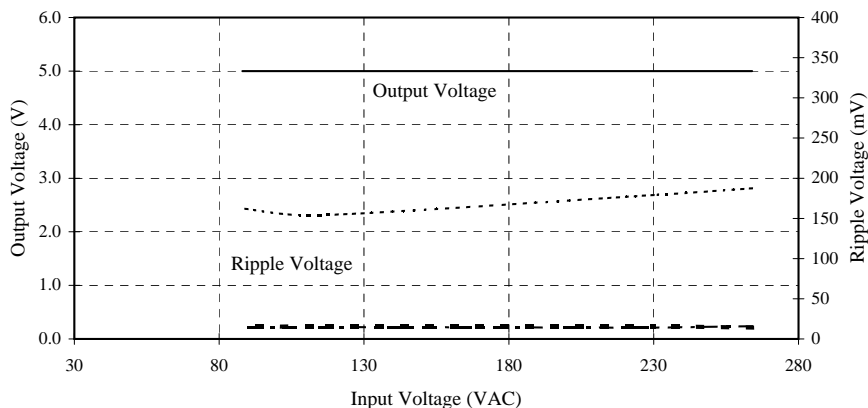

12V

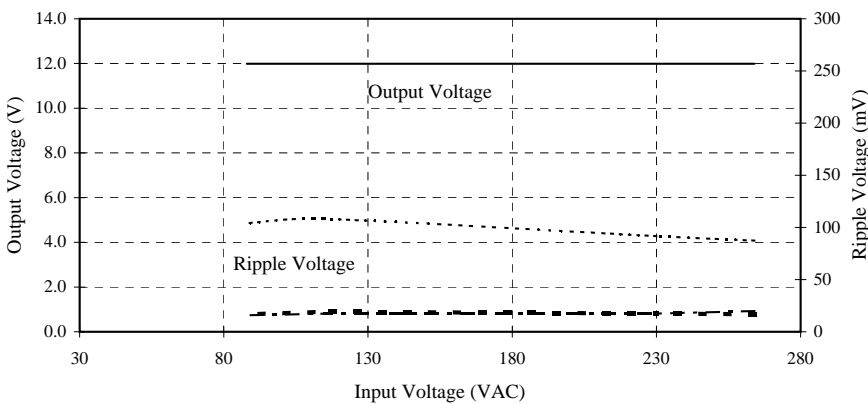

24V

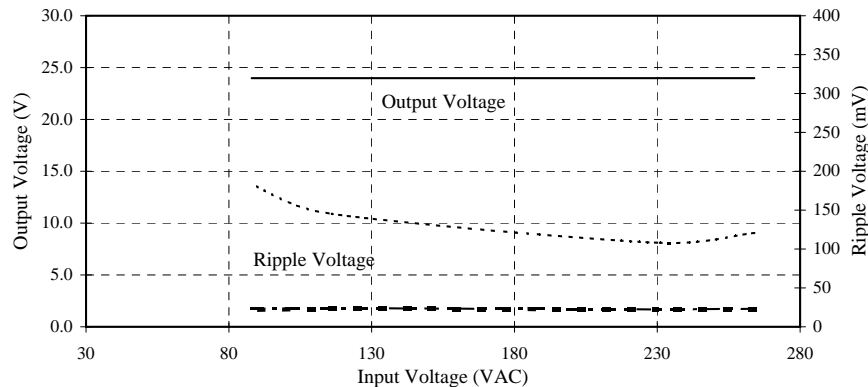

2-1 Steady State Data

(3) Efficiency And Input Current Vs Output Current

Conditions: $T_a = 25^\circ\text{C}$
 $V_{in} = 88\text{VAC}$
 115VAC
 230VAC
 264VAC

5V

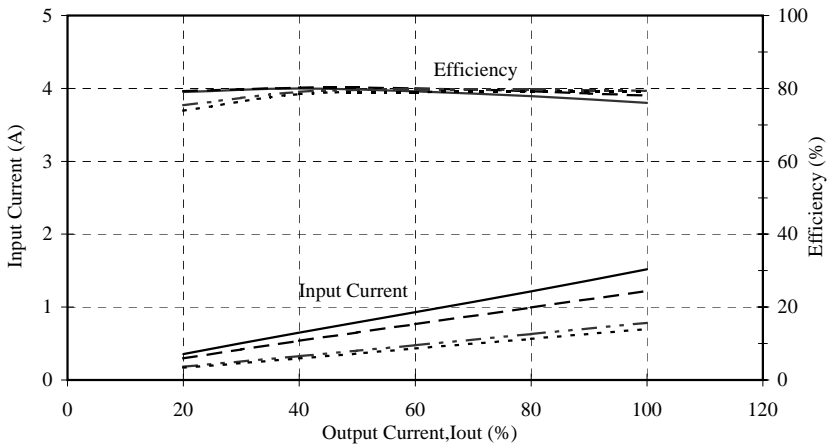

12V

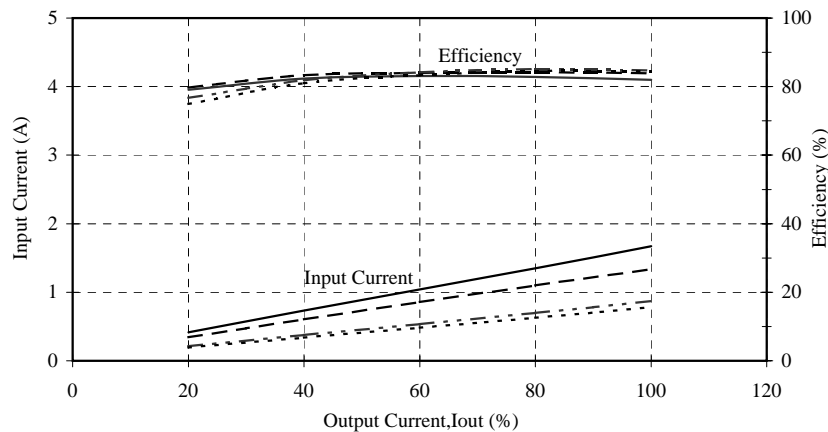

24V

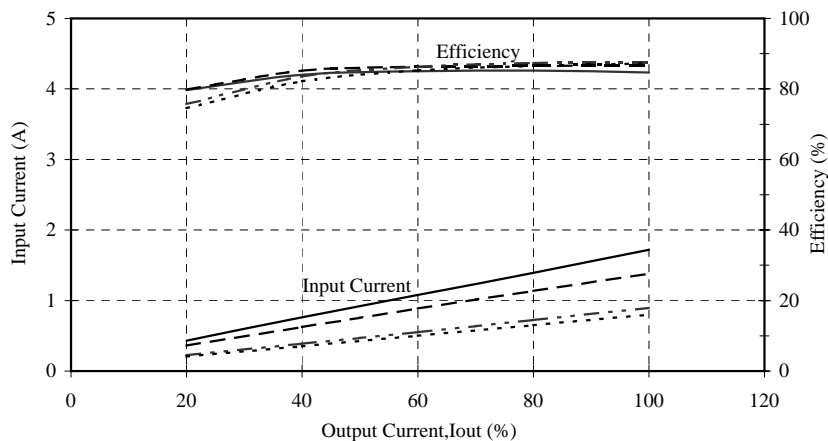

2-2 Warm up voltage drift characteristics

Conditions: Vin : 230VAC
Iout : 100%
Ta : 25°C

5V

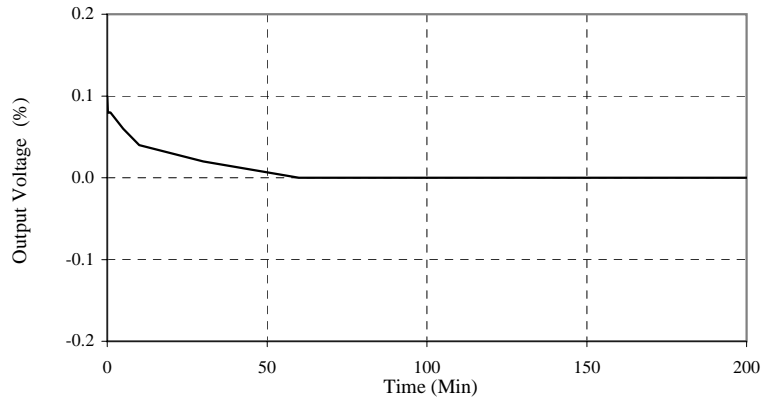

12V

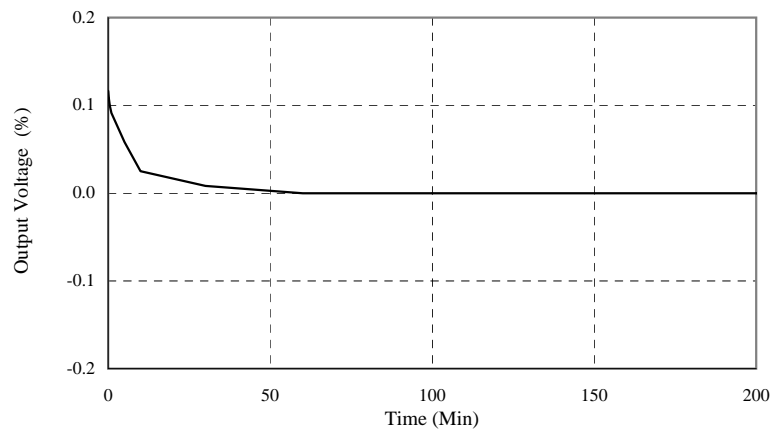

24V

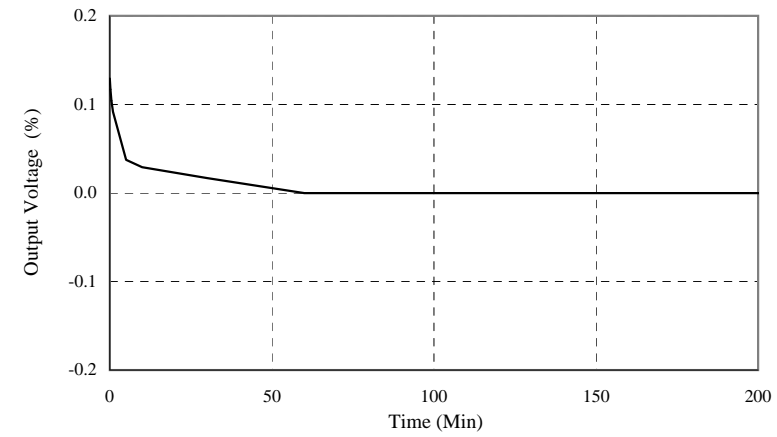

2-3 Over current protection (OCP) characteristics

Conditions: Vin : 88 VAC -----
 115 VAC
 230 VAC ————
 264 VAC - - - - -
 Ta : 25°C

5V

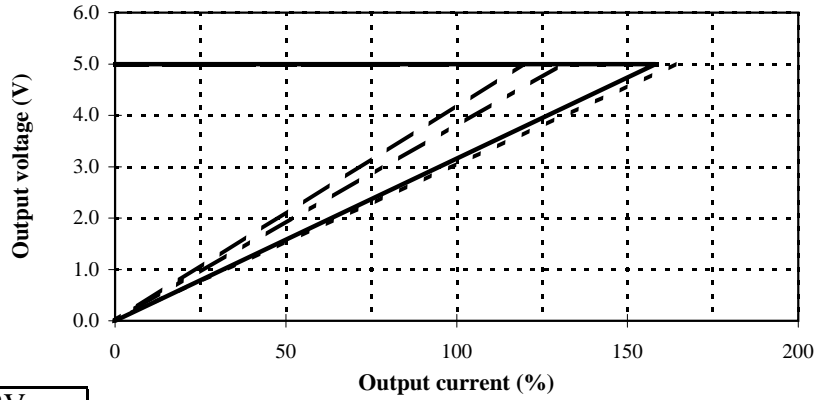

12V

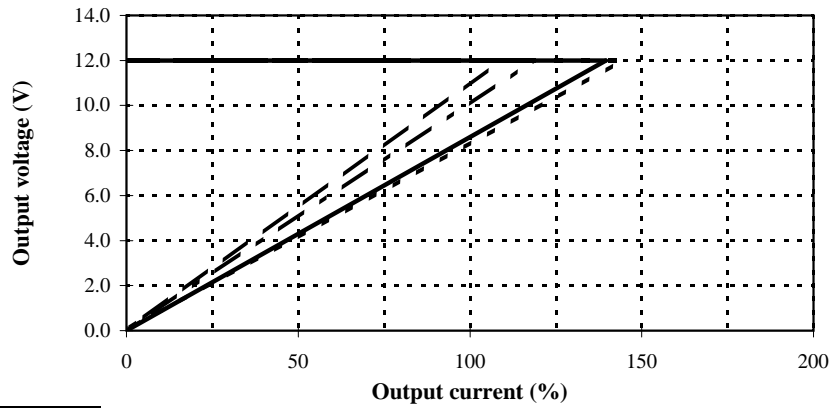

24V

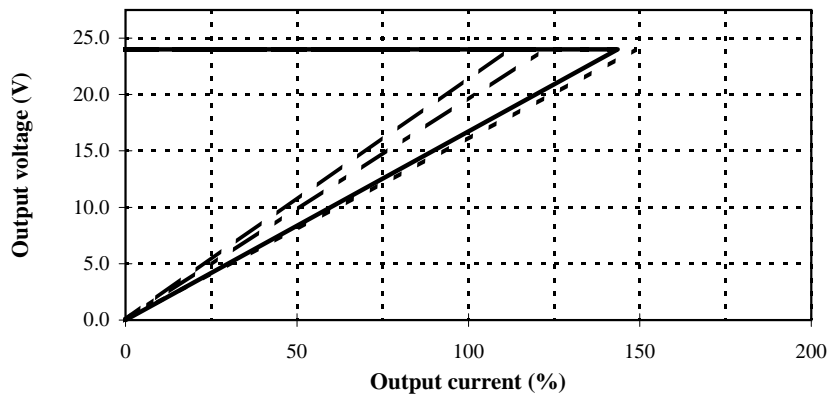

2.3 Over current protection (OCP) characteristics

Conditions: Vin : 115VAC
 Ta : -25°C - - - - -
 25°C - ·····
 50°C - ———

5V

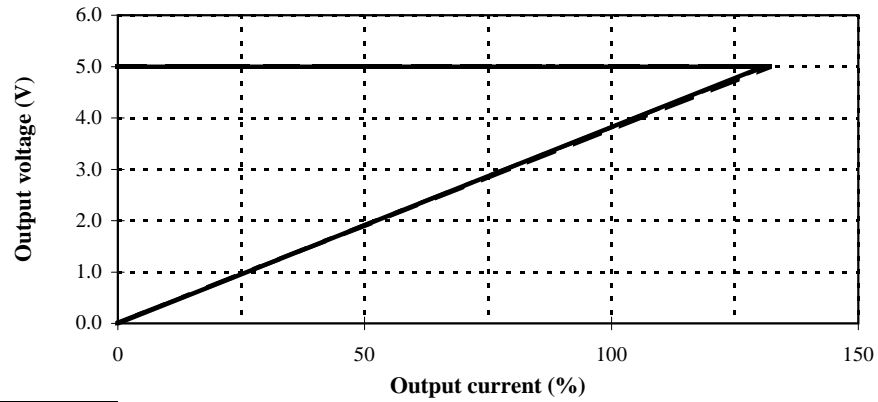

12V

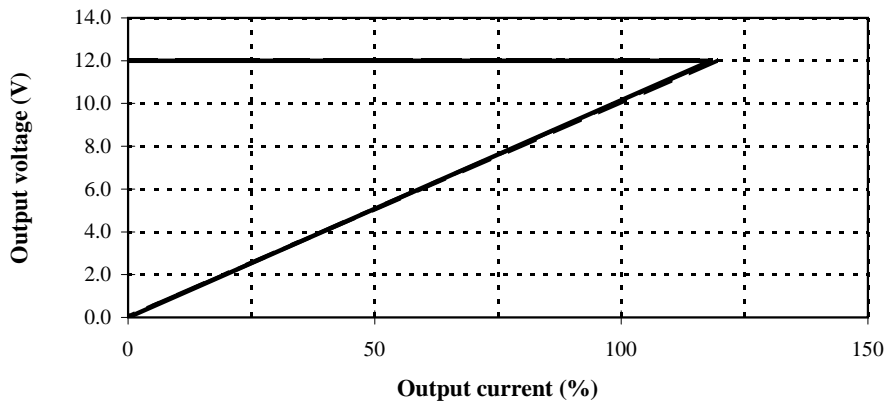

24V

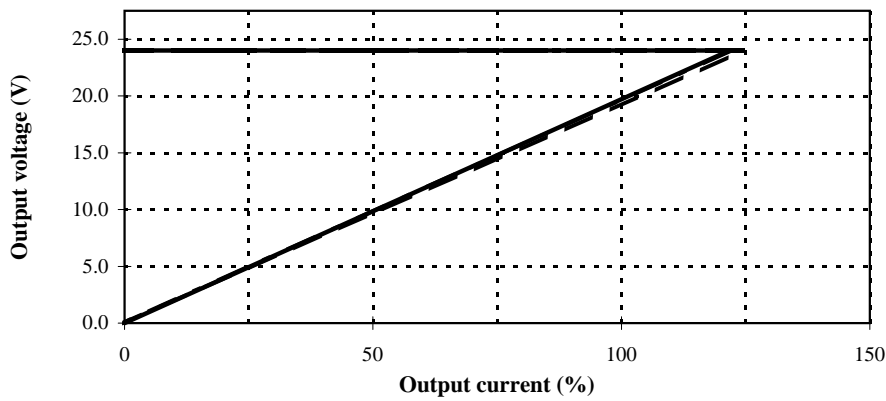

2.3 Over current protection (OCP) characteristics

Conditions: Vin : 230VAC
 Ta : -25°C -----
 25°C
 50°C _____

5V

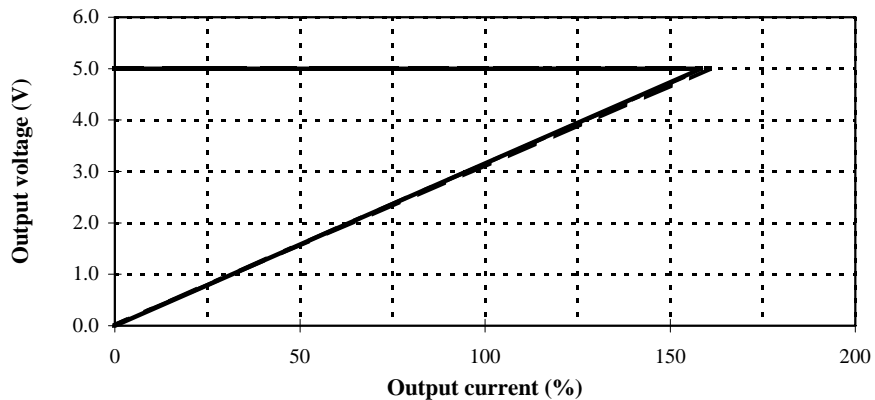

12V

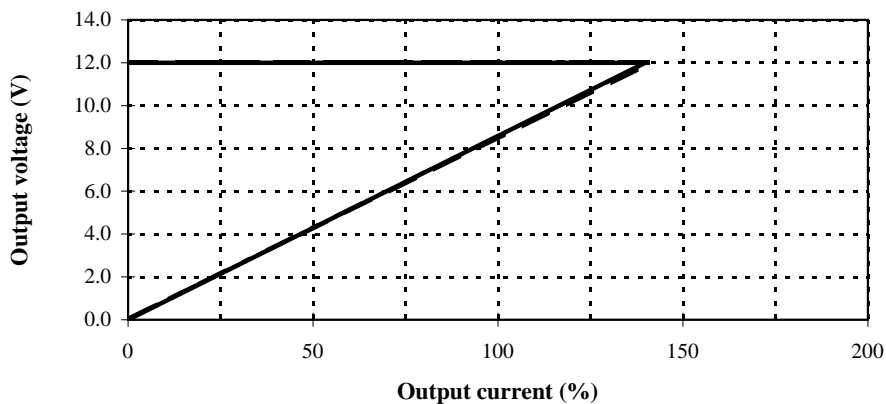

24V

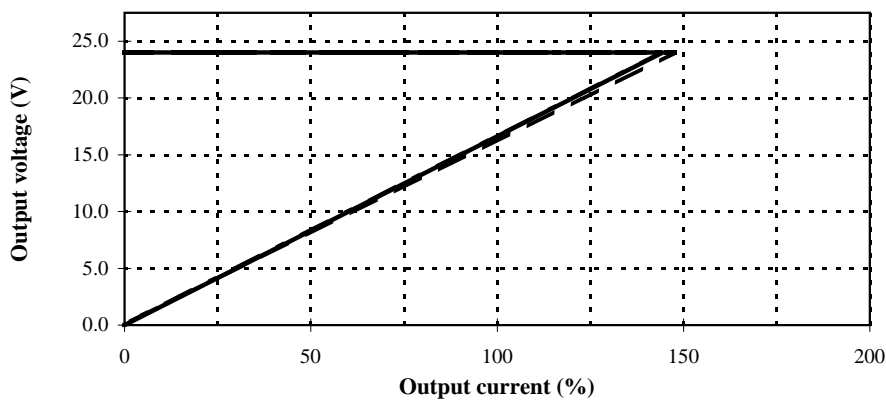

2-4 Over voltage protection (OVP) characteristics

Conditions : $T_a = 25^{\circ}\text{C}$
 $V_{in} = 230\text{VAC}$
 $I_{out} = 0\%$

5V

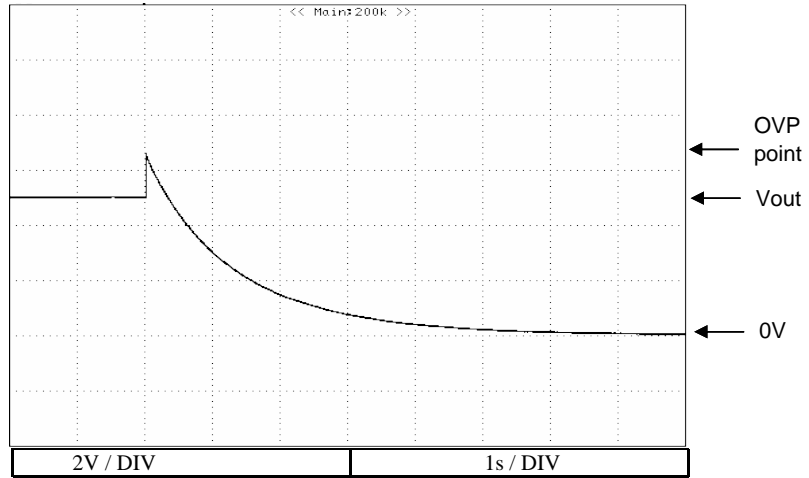

12V

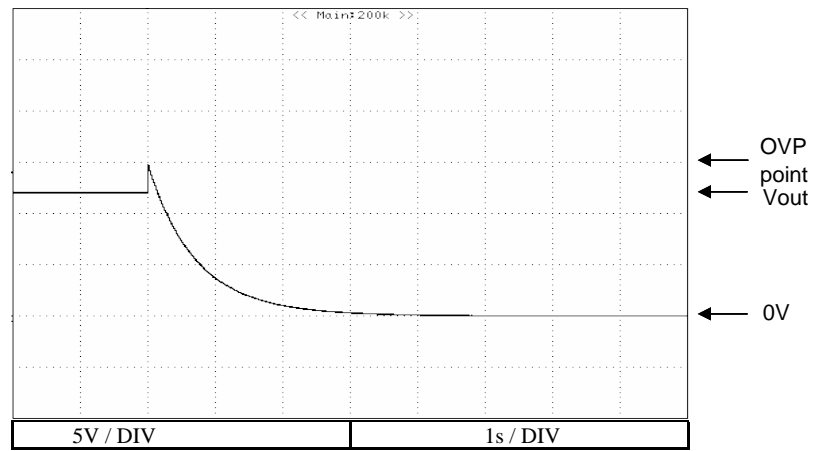

24V

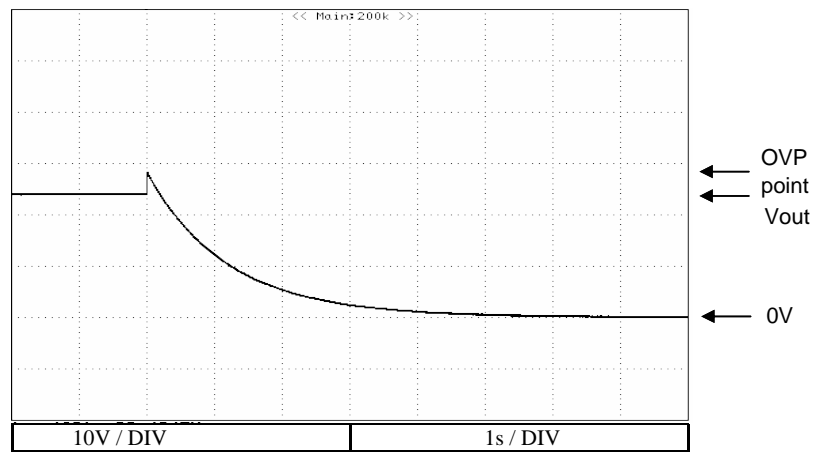

2-5 Output Rise Characteristics

Conditions: Vin : 88VAC (A)
 : 115VAC (B)
 : 230VAC (C)
 : 264VAC (D)
 Iout : 0%
 Ta : 25°C

5V

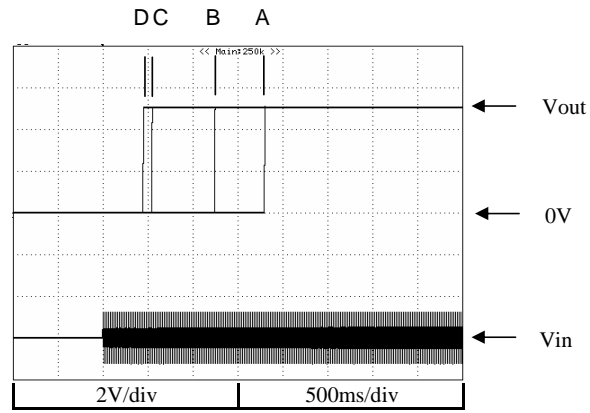

12V

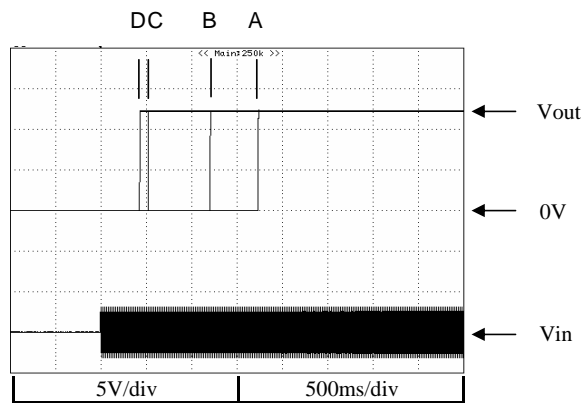

24V

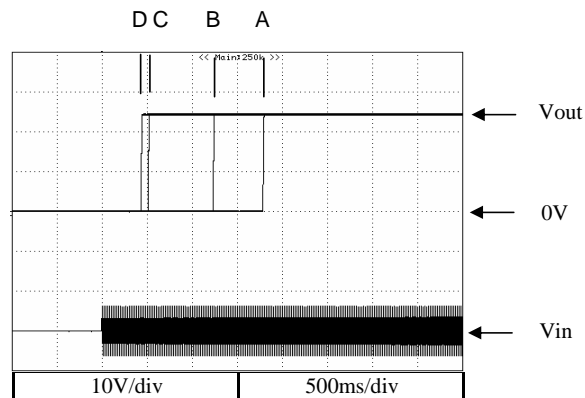

2-5 Output Rise Characteristics

Conditions: Vin : 88VAC (A)
 : 115VAC (B)
 : 230VAC (C)
 : 264VAC (D)
 Iout : 100%
 Ta : 25°C

5V

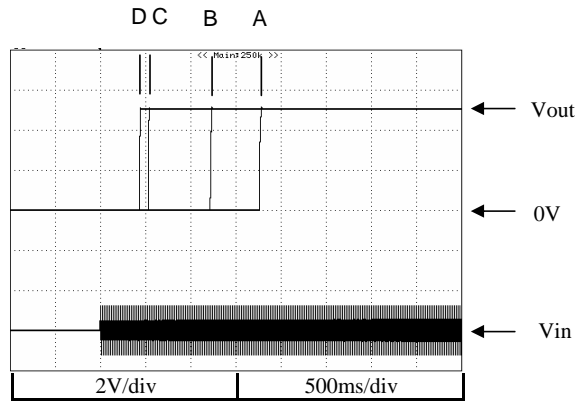

12V

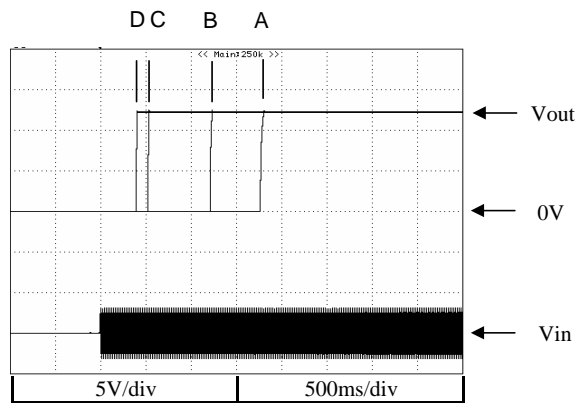

24V

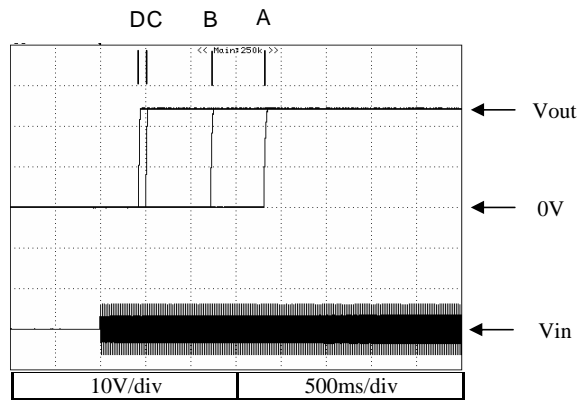

2-6 Output Fall Characteristics

Conditions: Vin : 88VAC (A)
 : 115VAC (B)
 : 230VAC (C)
 : 264VAC (D)
 Iout : 0%
 Ta : 25°C

5V

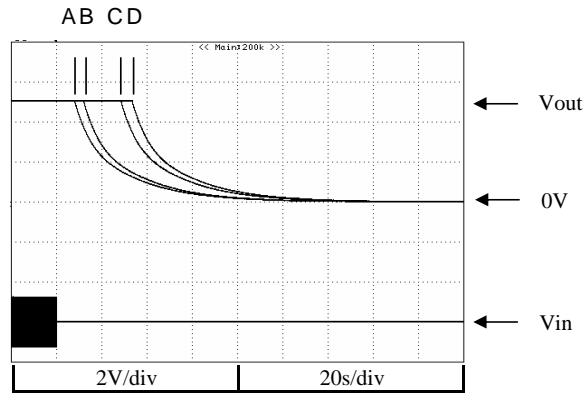

12V

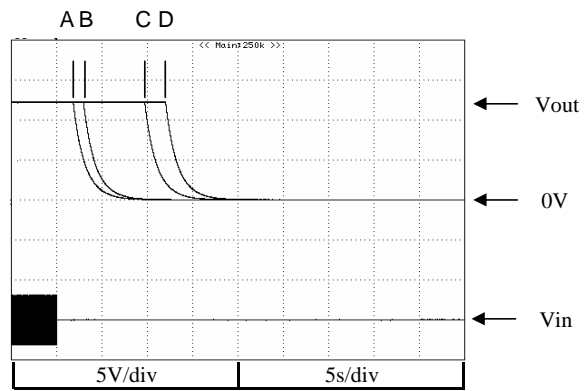

24V

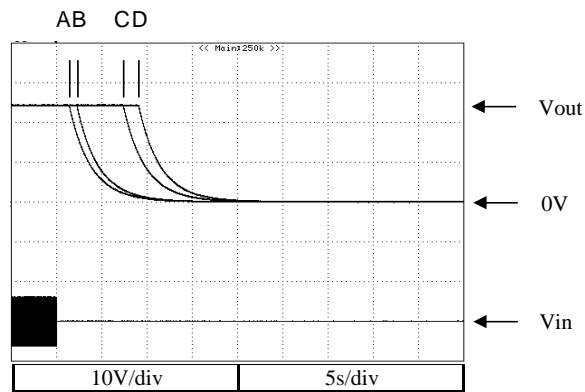

2-6 Output Fall Characteristics

Conditions: Vin : 88VAC (A)
 : 115VAC (B)
 : 230VAC (C)
 : 264VAC (D)
 Iout : 100%
 Ta : 25°C

5V

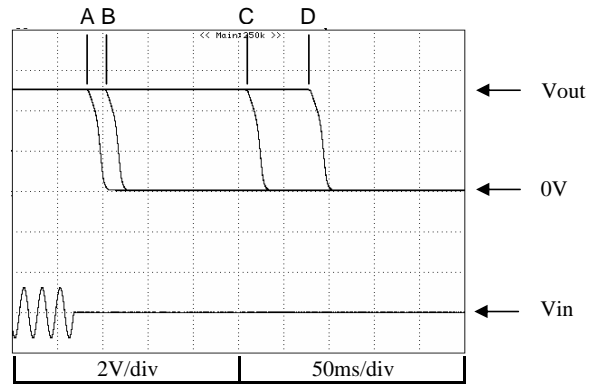

12V

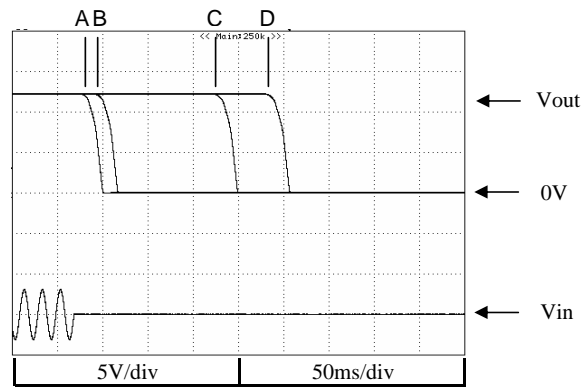

24V

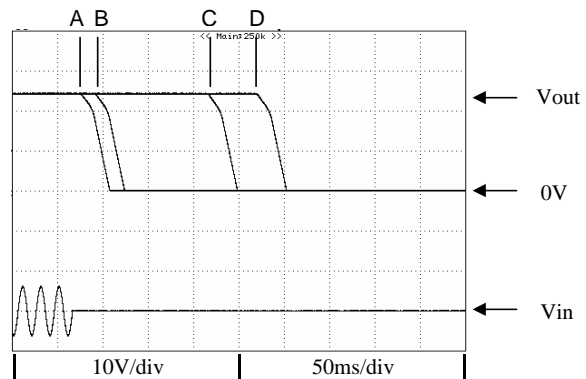

2-7 Hold Up Time Characteristics

Conditions Vin: 115VAC -----
 230VAC _____
 Ta: 25°C

5V

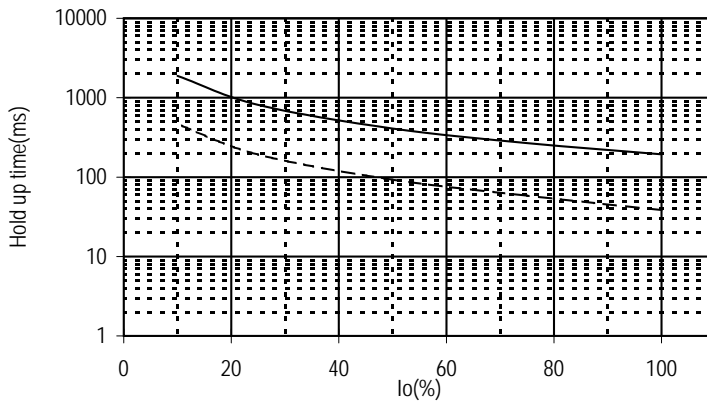

12V

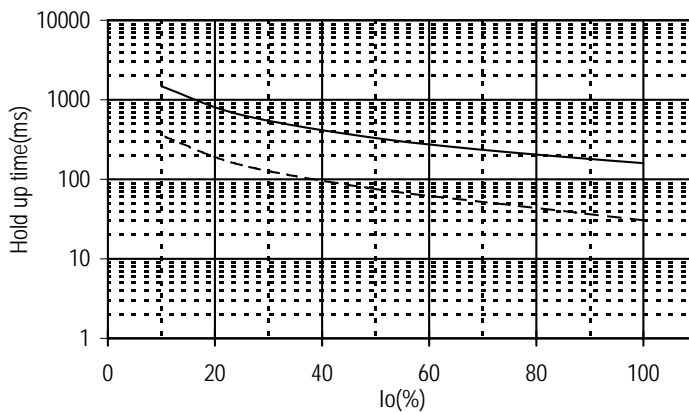

24V

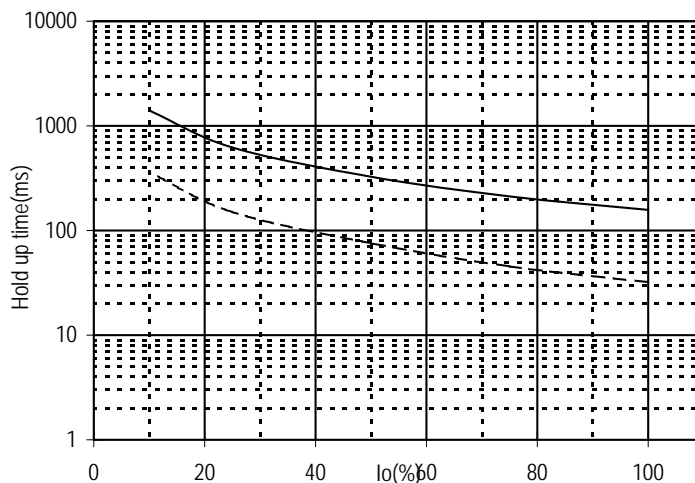

2-8 Dynamic Line Response Characteristics

Conditions : $V_{in} = 88 \leq 132$ VAC (A)
 $= 170 \leq 264$ VAC (B)
 $I_{out} = 100\%$
 $T_a = 25^{\circ}\text{C}$

5V

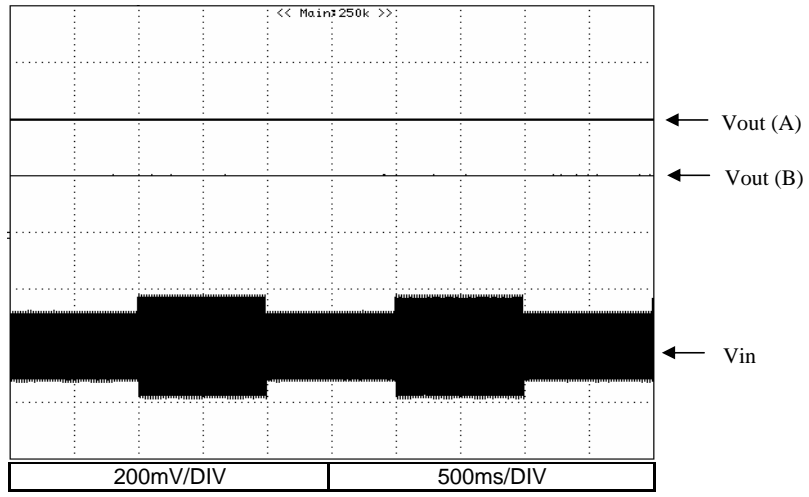

12V

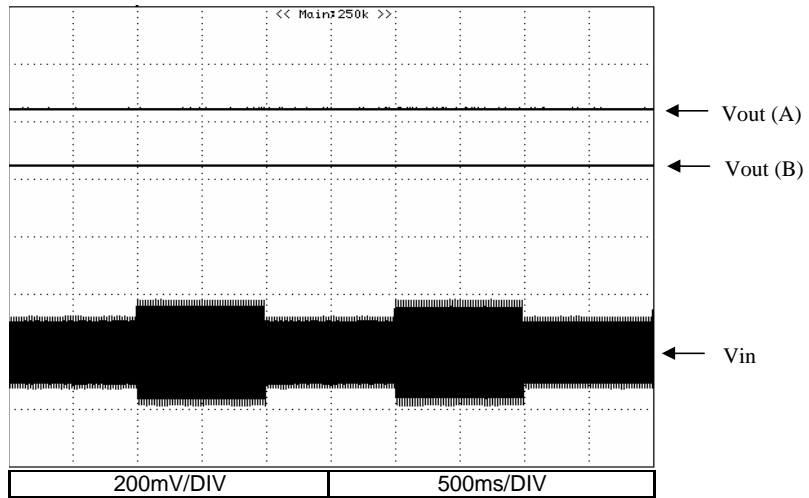

24V

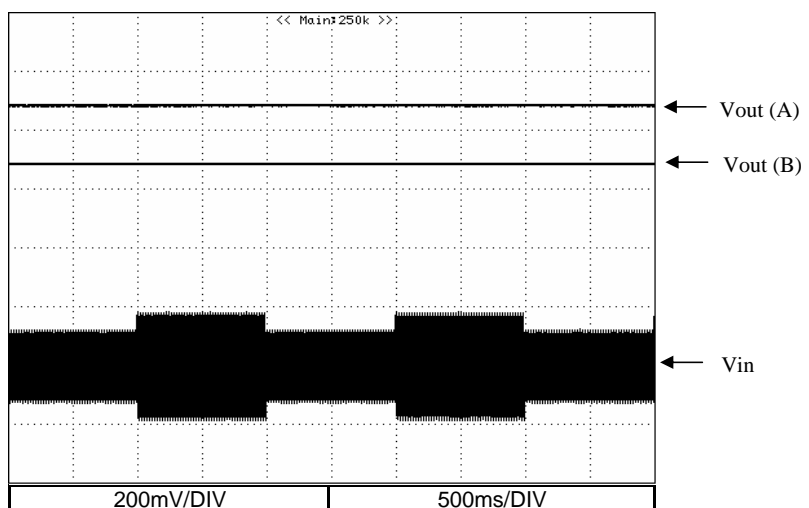

2-9 Dynamic Load Response Characteristics

Conditions : $V_{in} = 115VAC$
 $T_a = 25^{\circ}C$

5V

$f=100Hz$

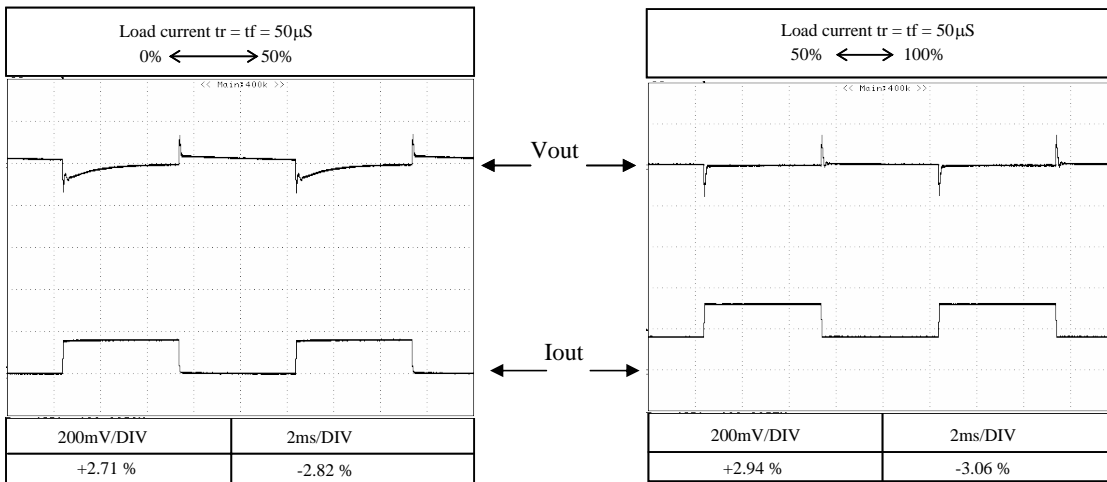

$f=1KHz$

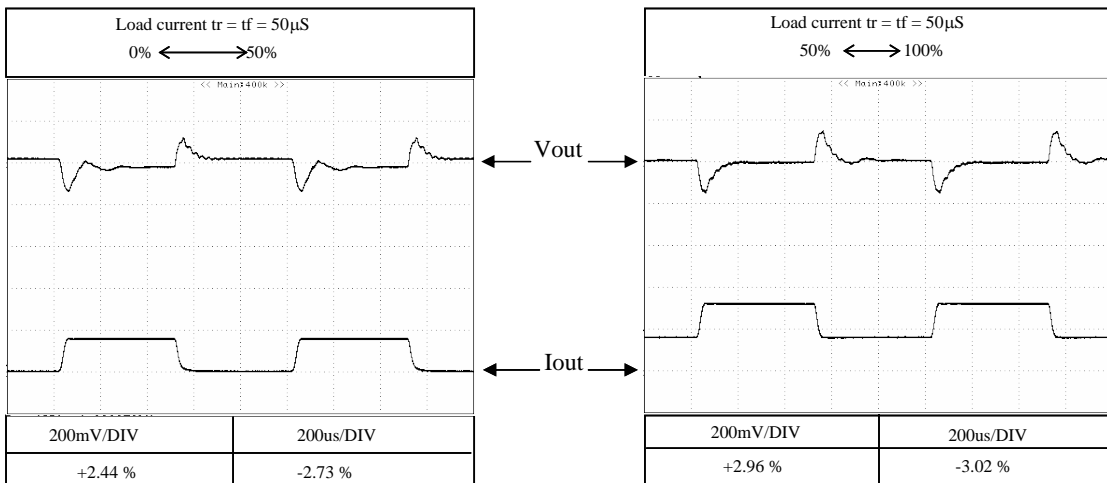

2-9 Dynamic Load Response Characteristics

Conditions : $V_{in} = 230VAC$
 $T_a = 25^{\circ}C$

5V

$f=100Hz$

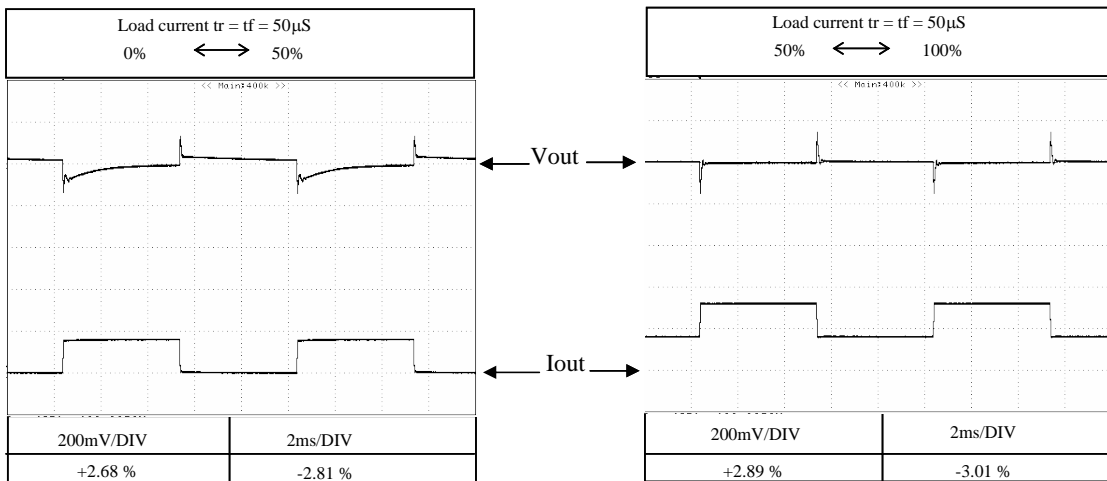

$f=1KHz$

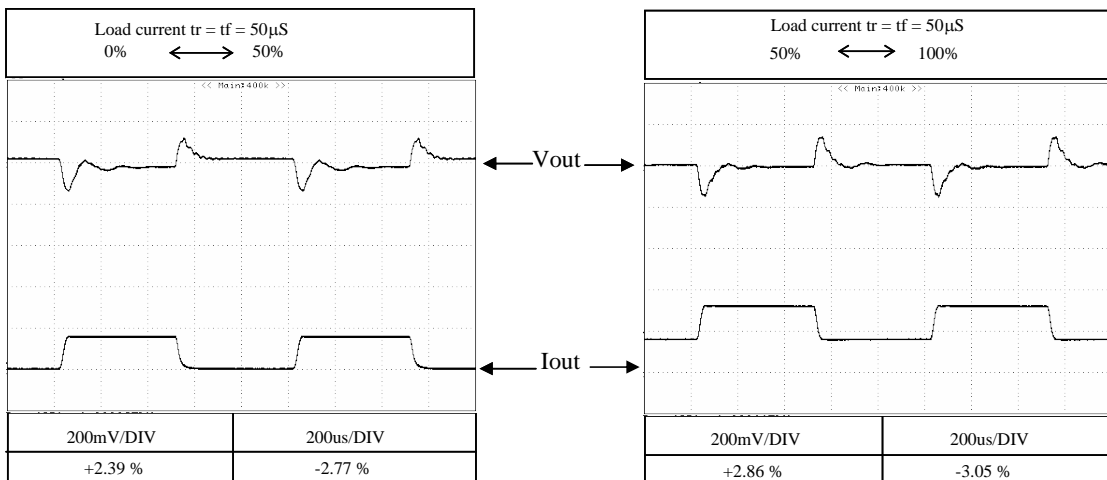

2-9 Dynamic Load Response Characteristics

Conditions : $V_{in} = 115VAC$
 $T_a = 25^{\circ}C$

12V

$f=100Hz$

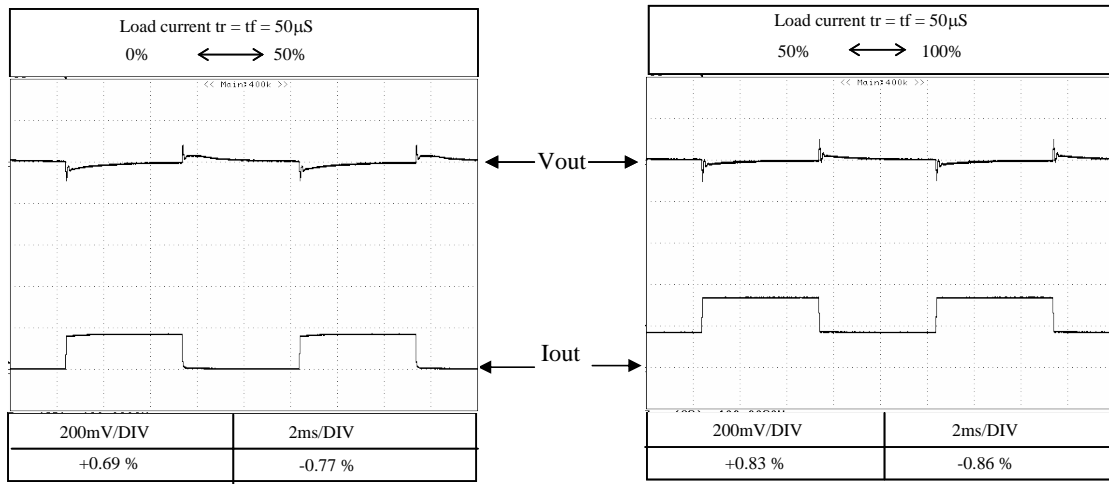

$f=1KHz$

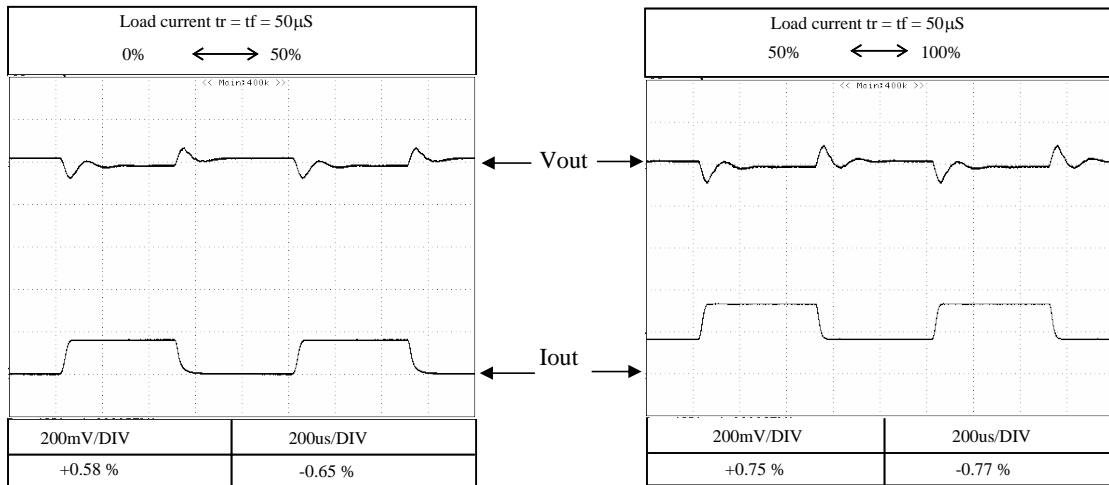

2-9 Dynamic Load Response Characteristics

Conditions $V_{in} = 230VAC$
 $T_a = 25^{\circ}C$

12V

$f=100Hz$

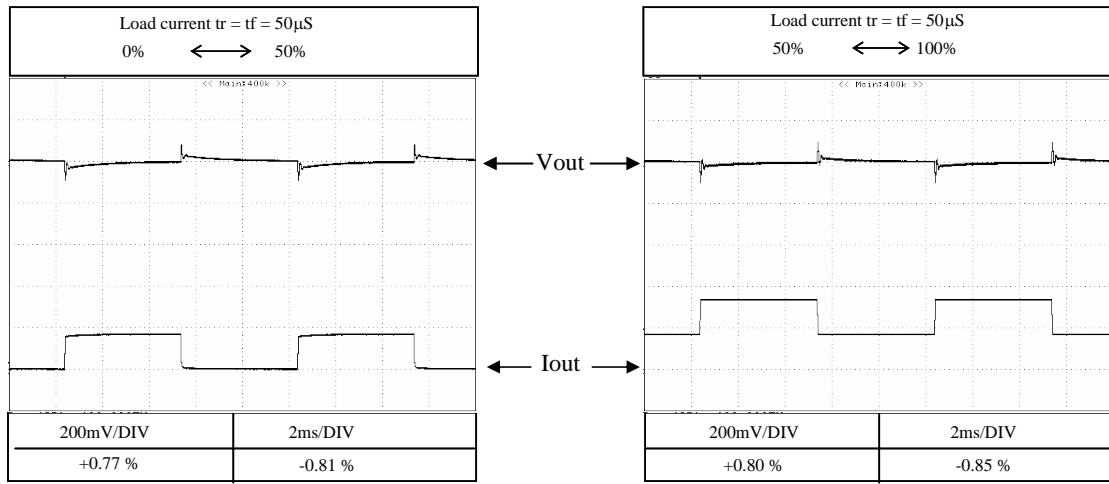

$f=1KHz$

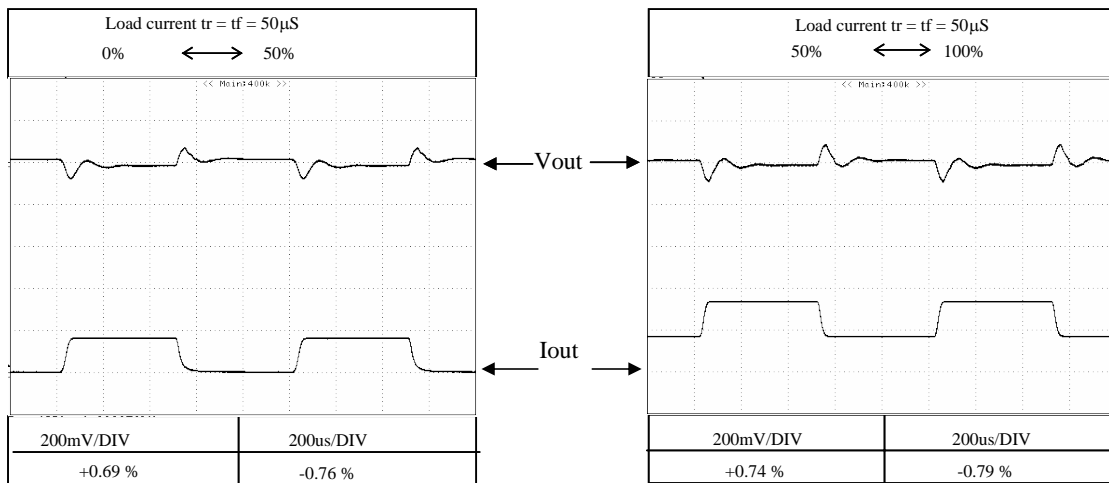

2-9 Dynamic Load Response Characteristics

Conditions : $V_{in} = 115VAC$
 $T_a = 25^{\circ}C$

24V

$f=100Hz$

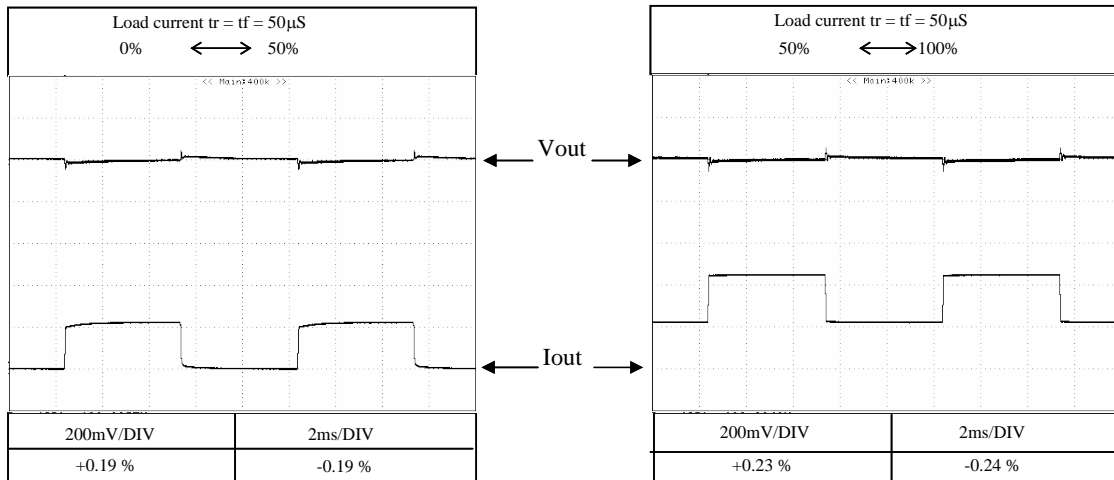

$f=1KHz$

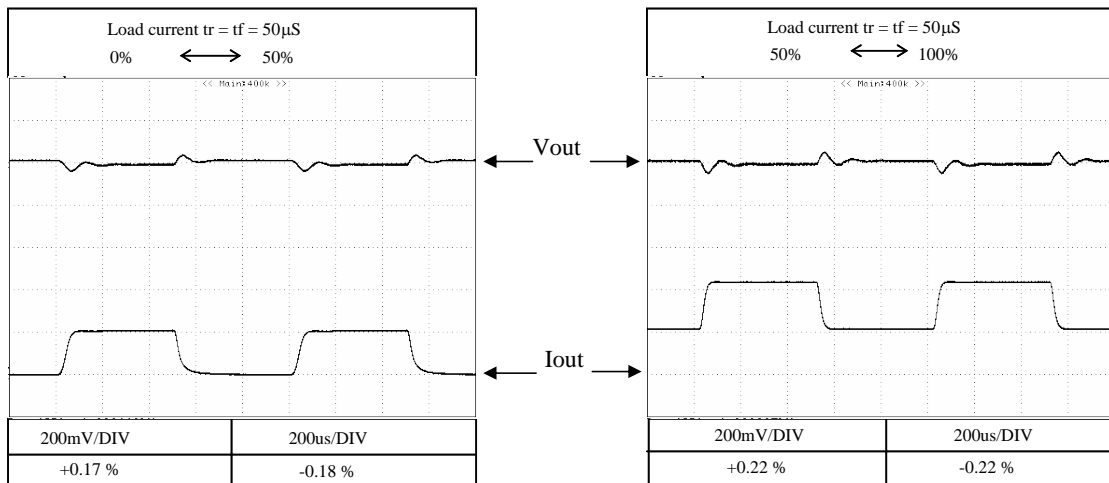

2-9 Dynamic Load Response Characteristics

Conditions $V_{in} = 230VAC$
 $T_a = 25^{\circ}C$

24V

$f=100Hz$

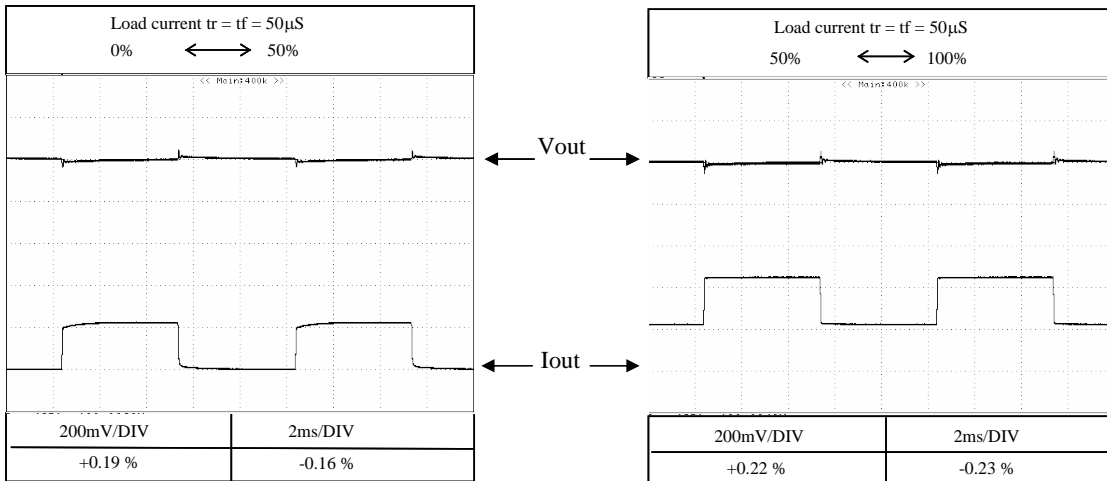

$f=1KHz$

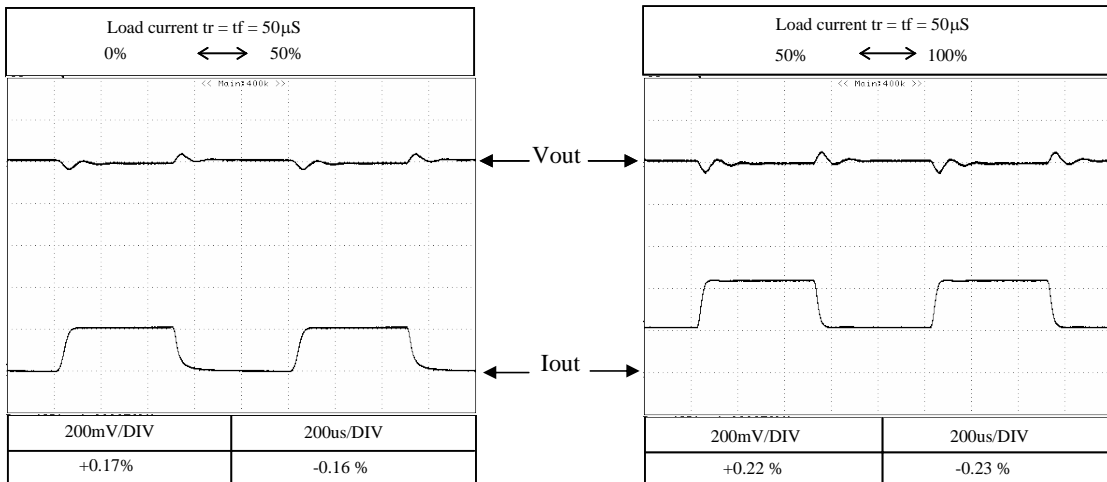

2-10 Response to Brown Out Characteristics

Conditions:

Vin : 115VAC

Iout : 100%

Ta : 25°C

5V

A = 48ms
B = 90ms

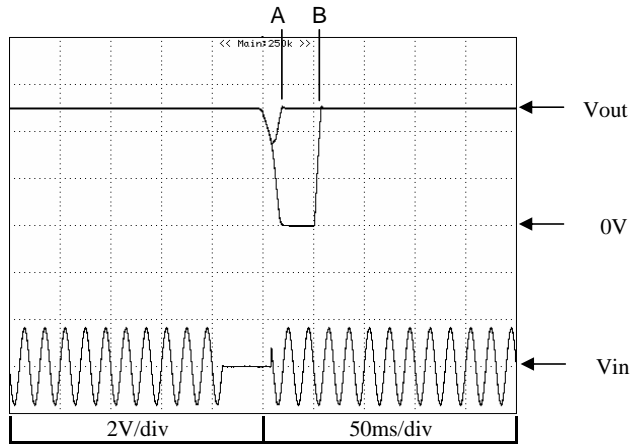

12V

A = 39ms
B = 80ms

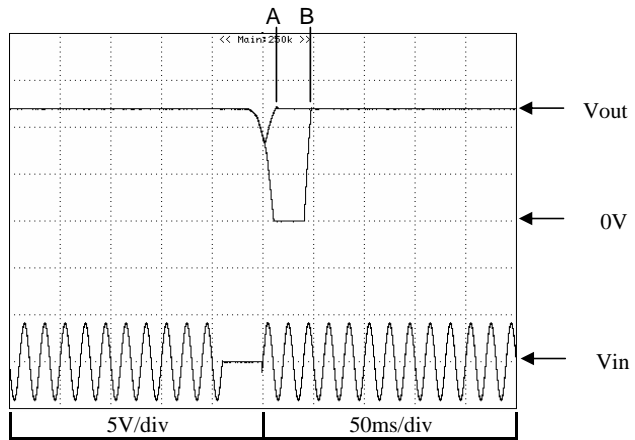

24V

A = 44ms
B = 90ms

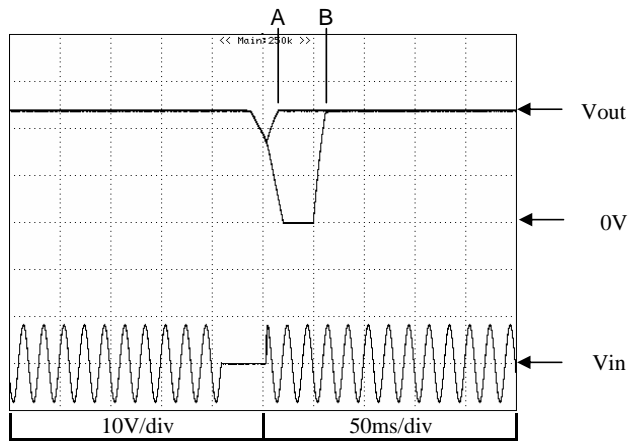

2-10 Response to Brown Out Characteristics

Conditions:

Vin : 230VAC

Iout : 100%

Ta : 25°C

5V

A = 203ms
B = 250ms

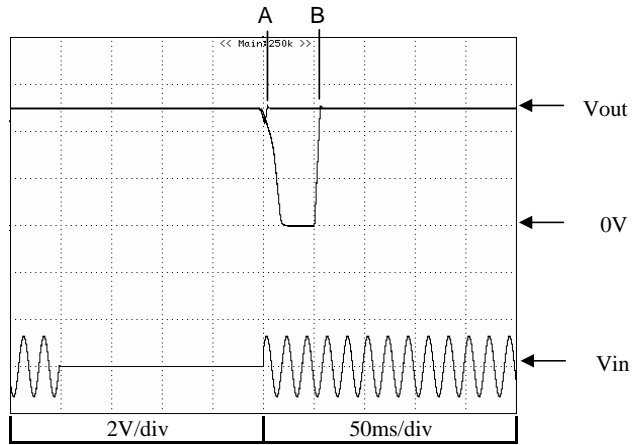

12V

A = 172ms
B = 220ms

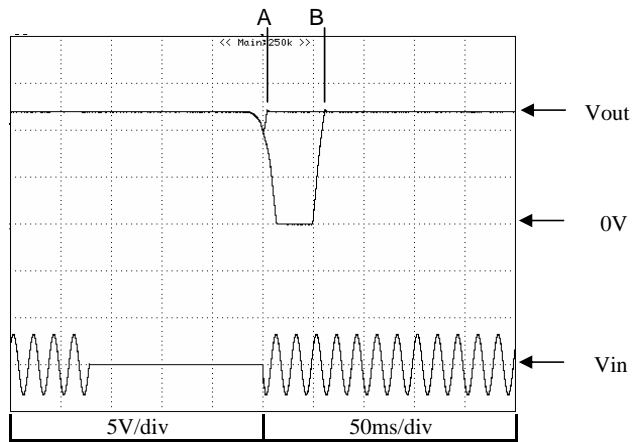

24V

A = 170ms
B = 220ms

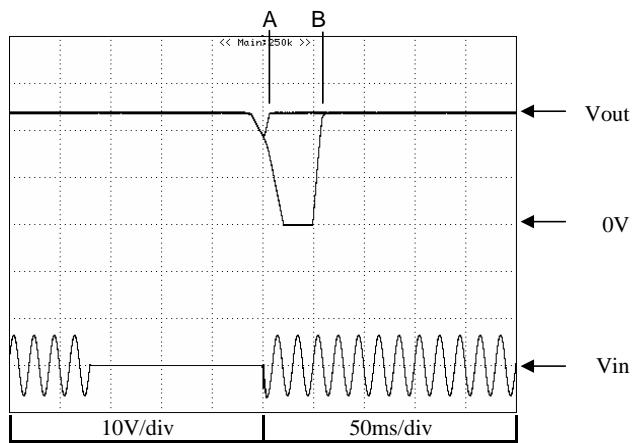

2-11 Inrush Current

Conditions : $V_{in} = 115VAC$
 $I_{out} = 100\%$
 $T_a = 25^{\circ}C$

5V

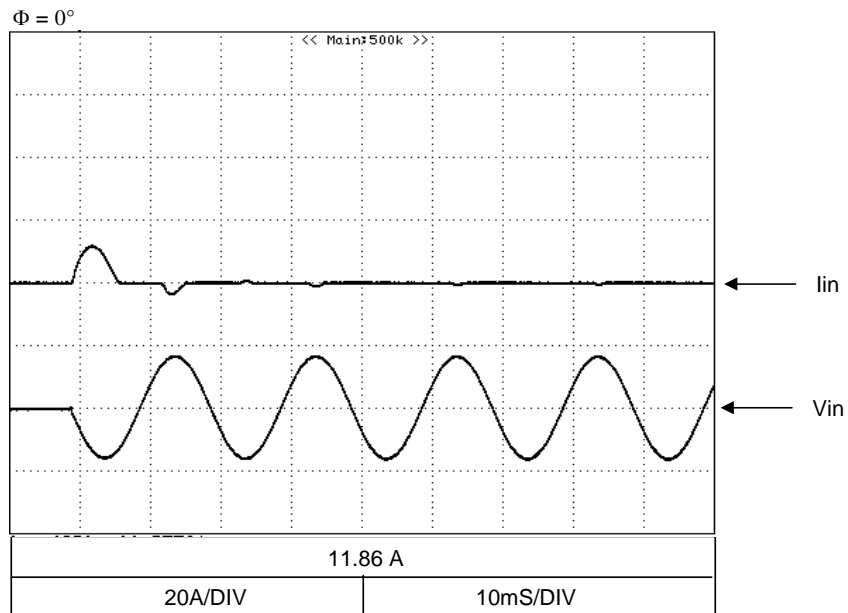
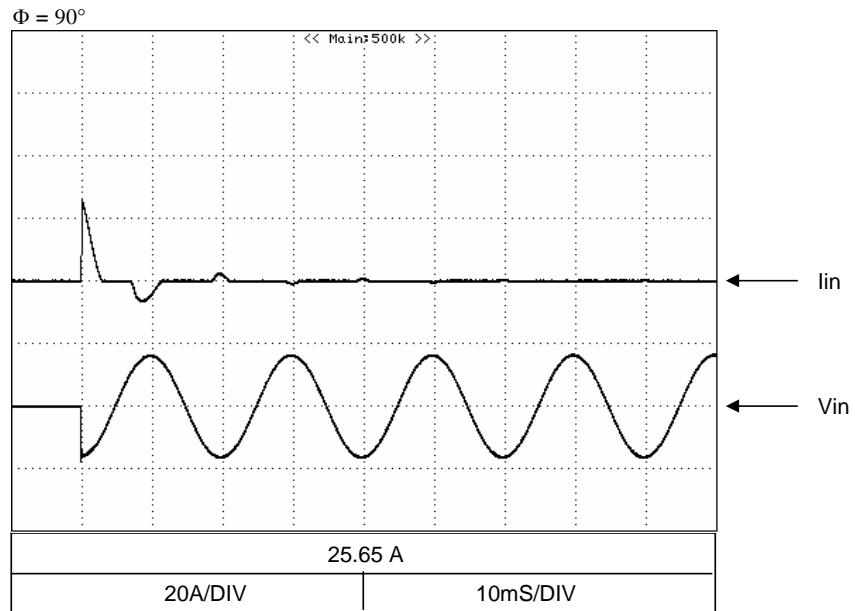

2-11 Inrush Current

Conditions : $V_{in} = 230VAC$
 $I_{out} = 100\%$
 $T_a = 25^{\circ}C$

5V

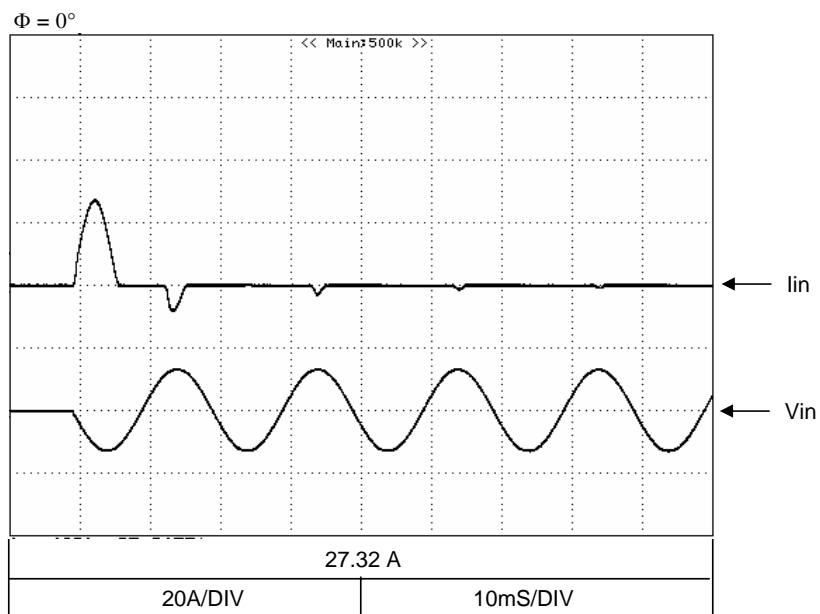
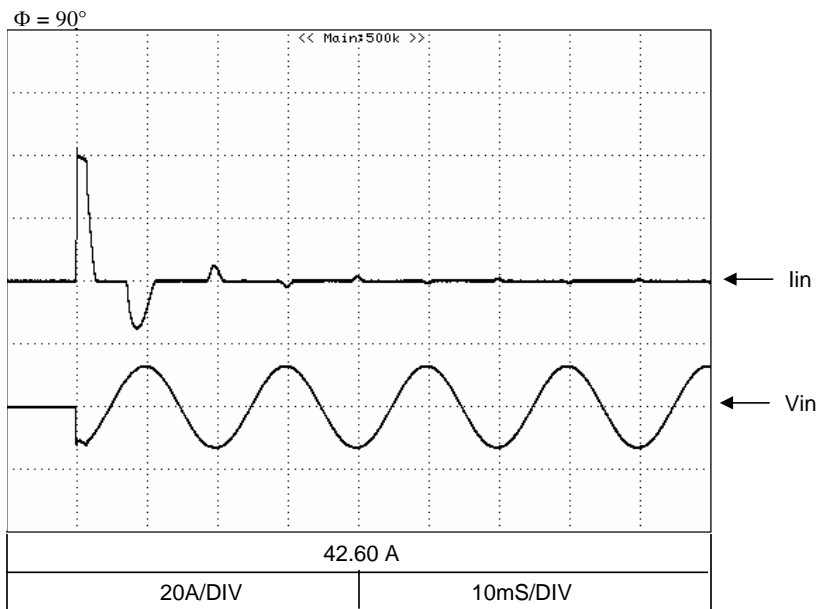

2-12 Input Current Harmonics

Conditions : Vin = 230VAC
Iout = 100%
Ta = 25°C
F = 60Hz

5V

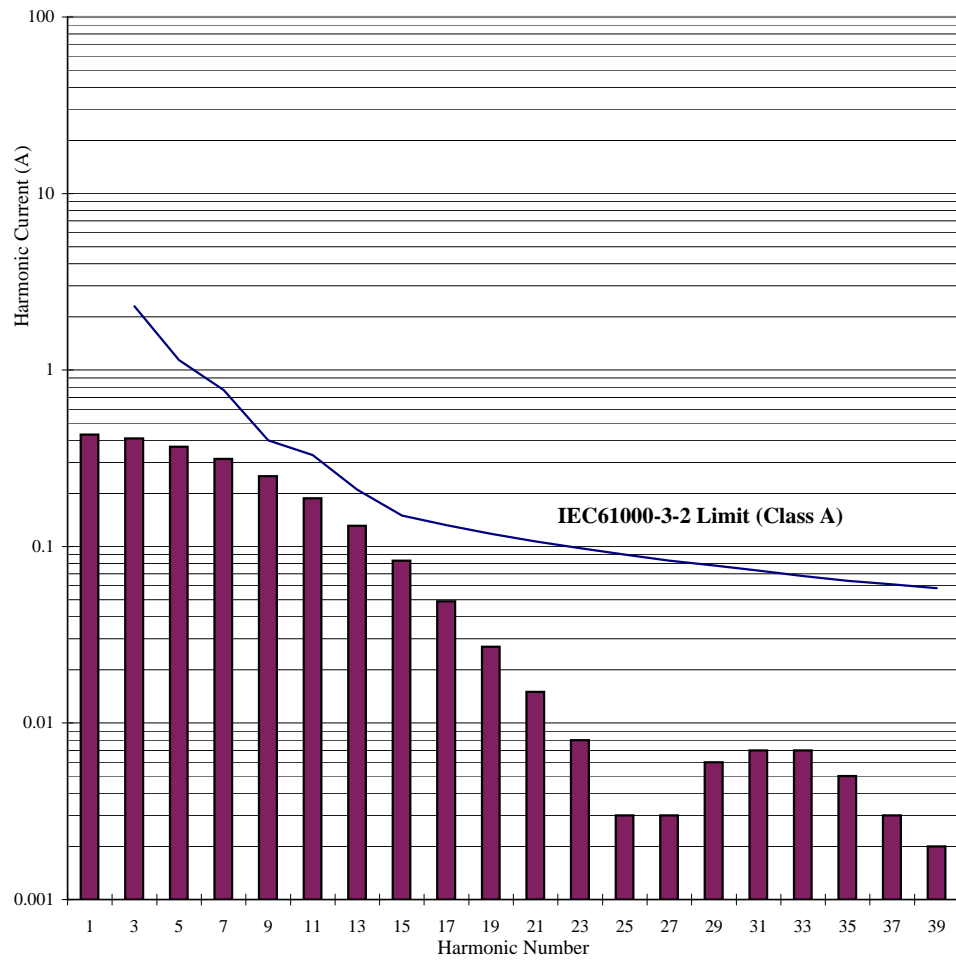

2-13 Leakage Current Characteristics

Conditions : I_{out} = 0%
 = 100%
 T_a = 25°C
 f = 50Hz

5V

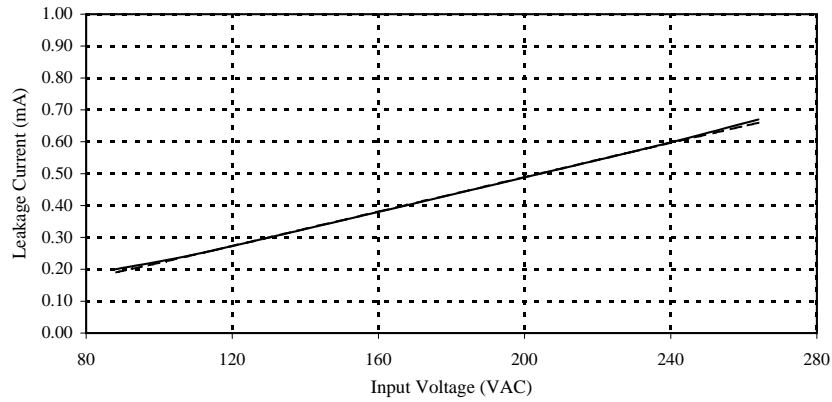

12V

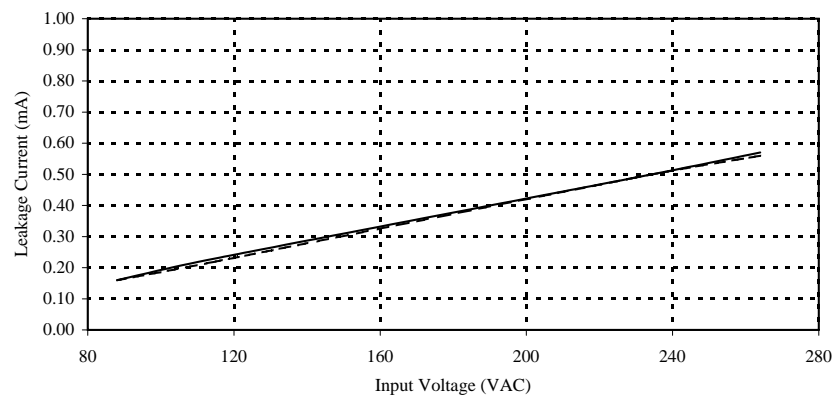

24V

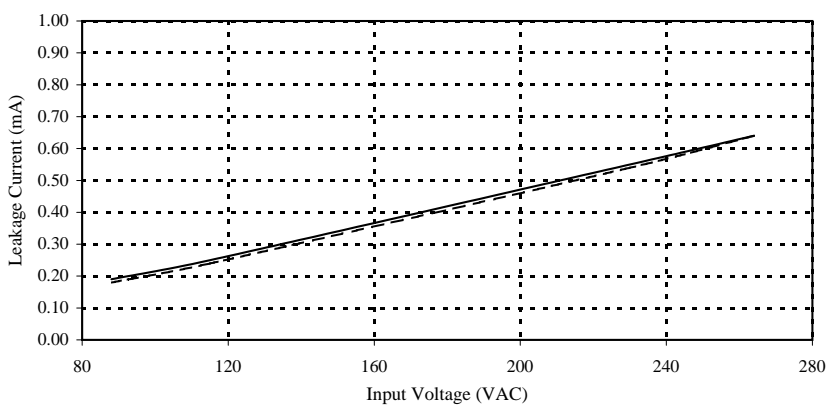

2-14 Output Ripple And Noise Waveform

Conditions

Vin = 230VAC
Iout = 100%
Ta = 25°C

NORMAL MODE

5V

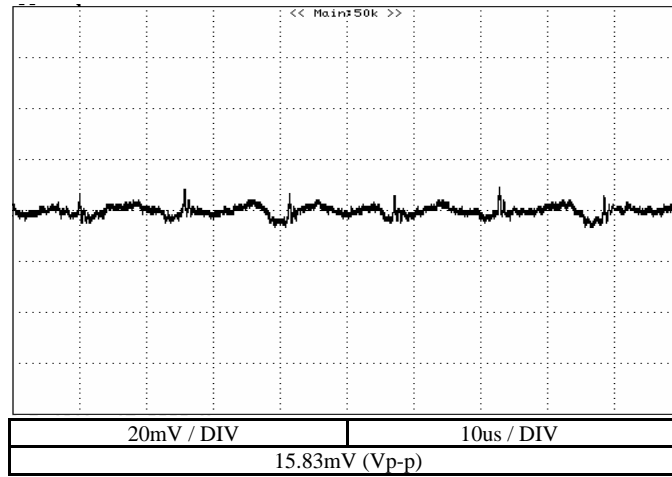

12V

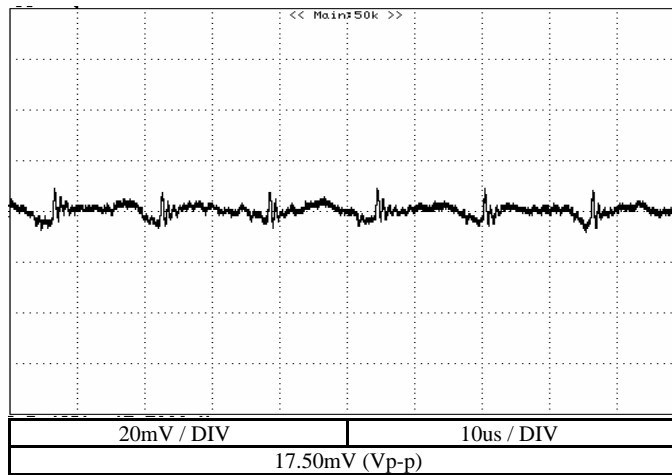

24V

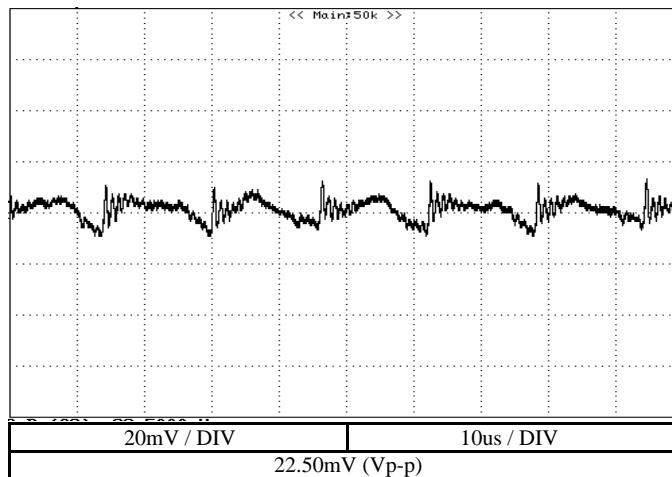

2-14 Output Ripple And Noise Waveform

Conditions

Vin = 230VAC
Iout = 100%
Ta = 25°C

NORMAL + COMMON MODE

5V

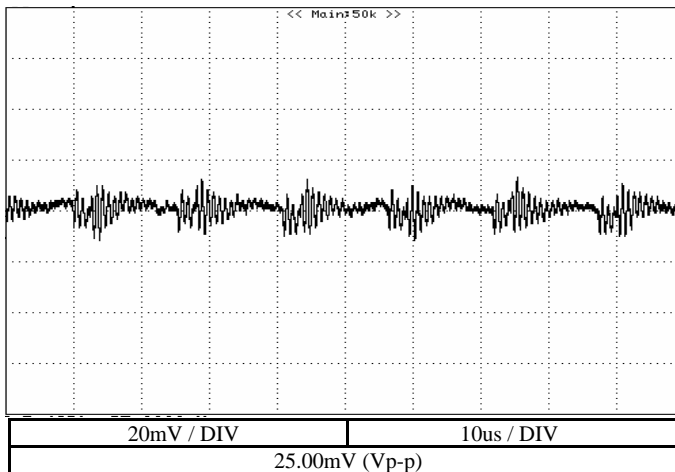

12V

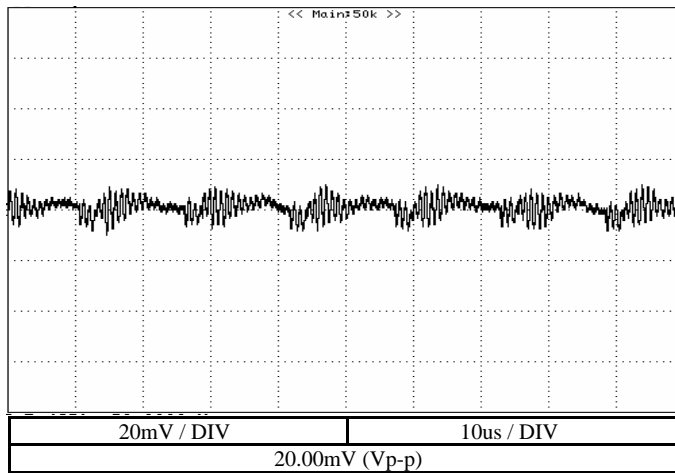

24V

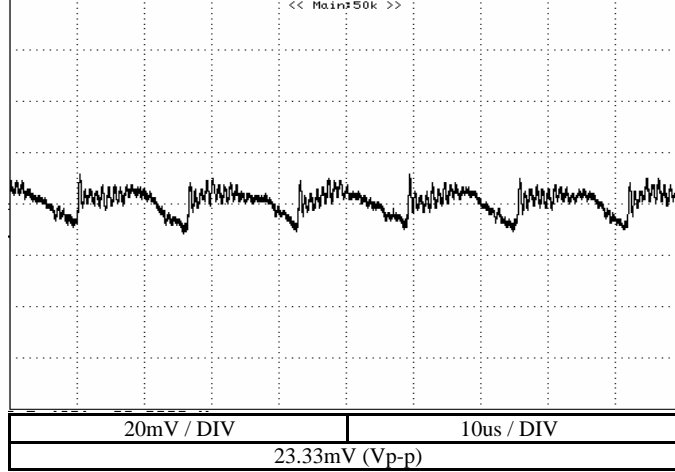

2-15 Electro-Magnetic Interference characteristics

Conditions: Vin : 115VAC
Iout : 100%

Conducted Emission

5V

Ref.	Point A (3.671MHz)	
	Limit (dB μ V)	Measure (dB μ V)
QP	56.00	46.92
AV	46.00	34.21

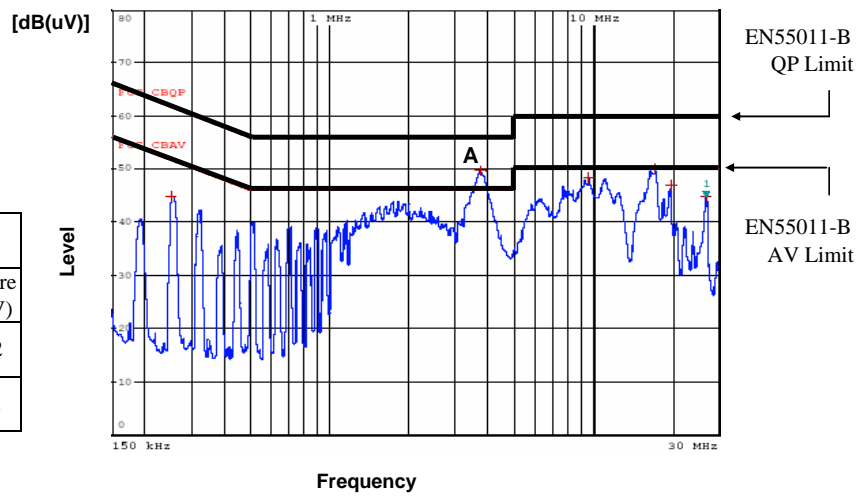

Phase : N

Ref.	Point B (3.766MHz)	
	Limit (dB μ V)	Measure (dB μ V)
QP	56.00	47.12
AV	46.00	35.85

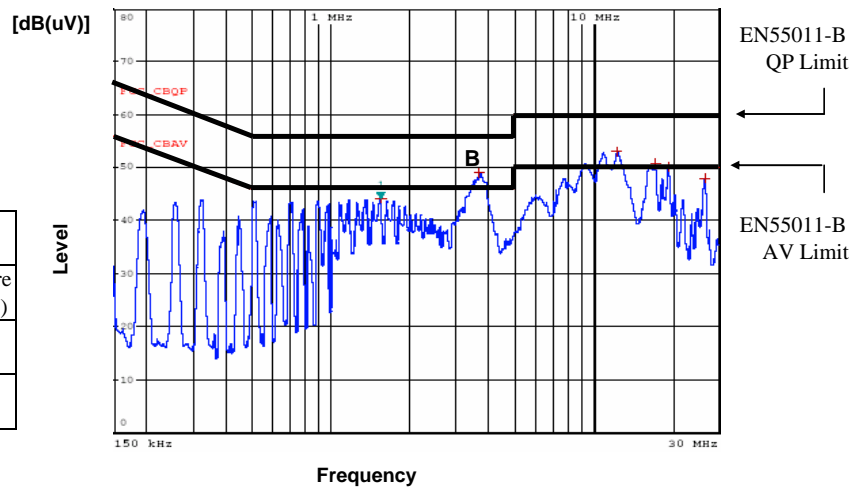

Phase : L

2-15 Electro-Magnetic Interference characteristics

Conditions: Vin : 230VAC
Iout : 100%

Conducted Emission

5V

Point A (17.749MHz)		
Ref.	Limit (dB μ V)	Measure (dB μ V)
QP	60.00	48.32
AV	50.00	41.35

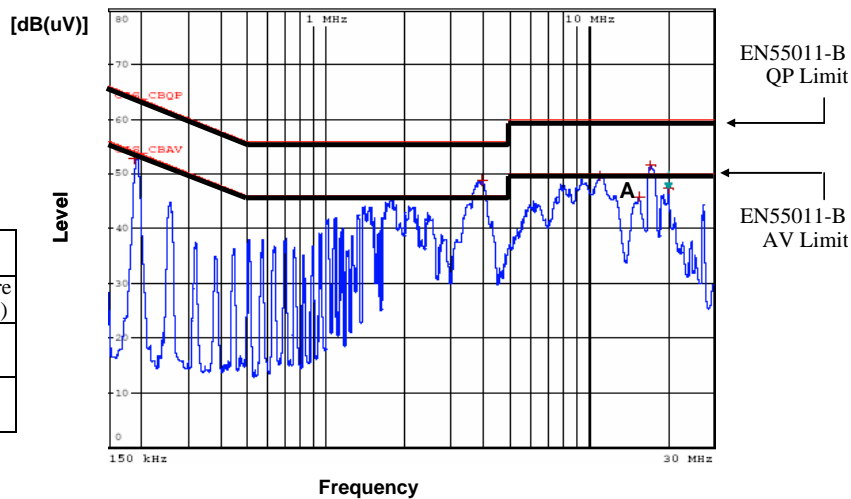

Phase : N

Point B (0.189MHz)		
Ref.	Limit (dB μ V)	Measure (dB μ V)
QP	64.08	52.11
AV	54.08	47.70

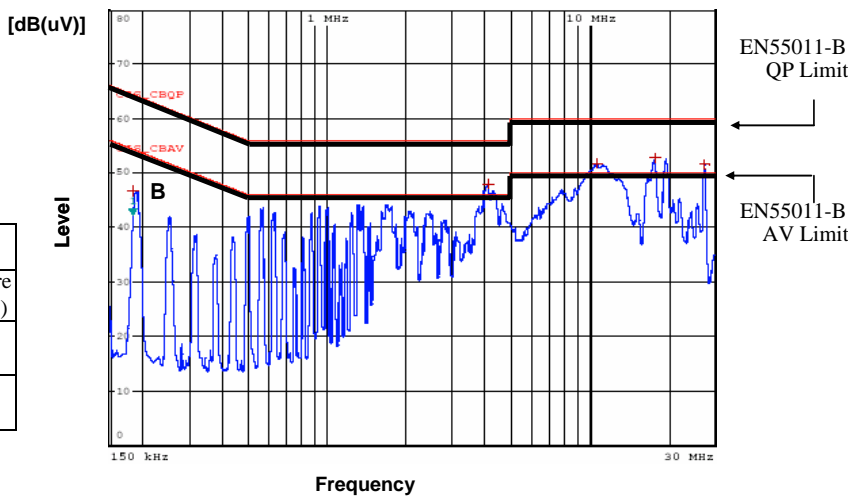

Phase : L

2-15 Electro-Magnetic Interference characteristics

Conditions: Vin : 115VAC
Iout : 100%

Conducted Emission

12V

Point A (1.127 MHz)		
Ref.	Limit (dB μ V)	Measure (dB μ V)
QP	56.00	44.02
AV	46.00	28.30

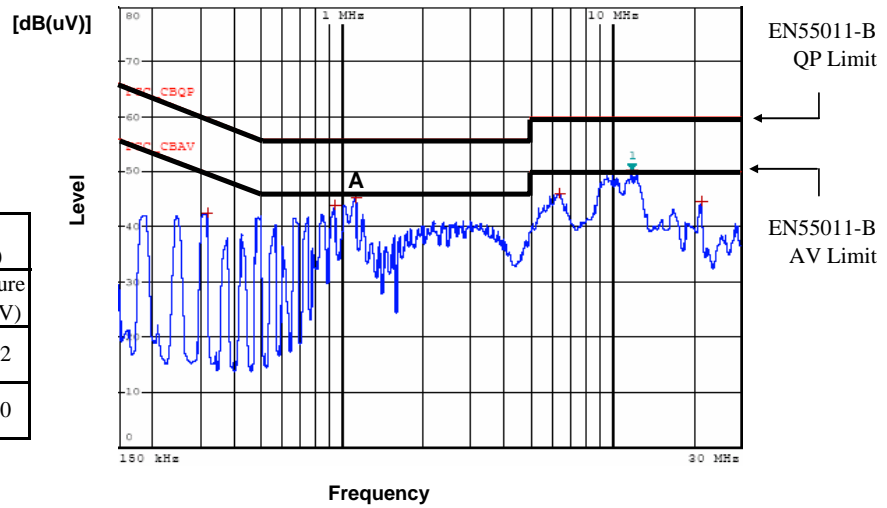

Phase : N

Point B (1.141 MHz)		
Ref.	Limit (dB μ V)	Measure (dB μ V)
QP	56.00	44.19
AV	46.00	27.77

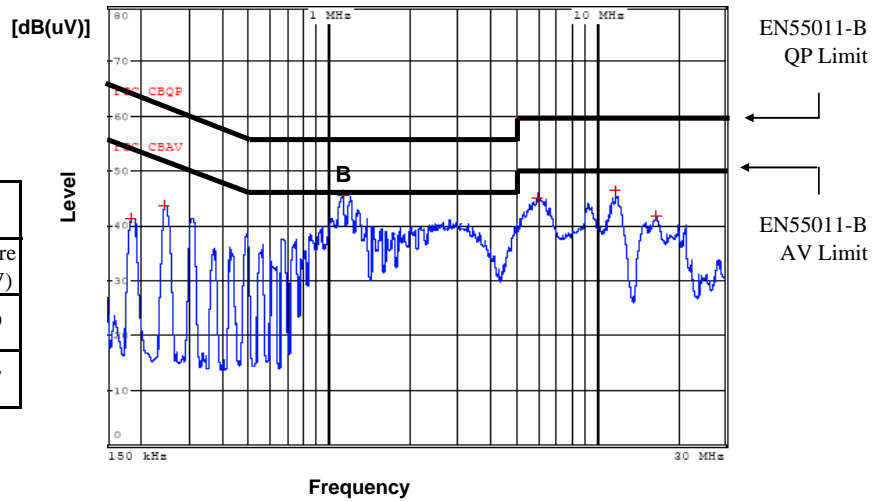

Phase : L

2-15 Electro-Magnetic Interference characteristics

Conditions: Vin : 230VAC
Iout : 100%

Conducted Emission

12V

Ref.	Point A (0.184 MHz)	
	Limit (dB μ V)	Measure (dB μ V)
QP	64.30	45.73
AV	54.30	44.13

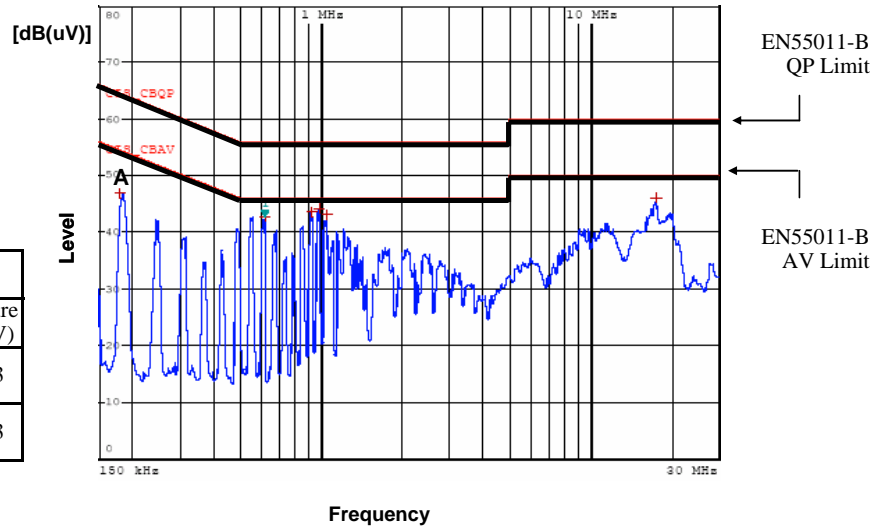

Phase : N

Ref.	Point B (0.183MHz)	
	Limit (dB μ V)	Measure (dB μ V)
QP	64.35	49.78
AV	54.35	47.28

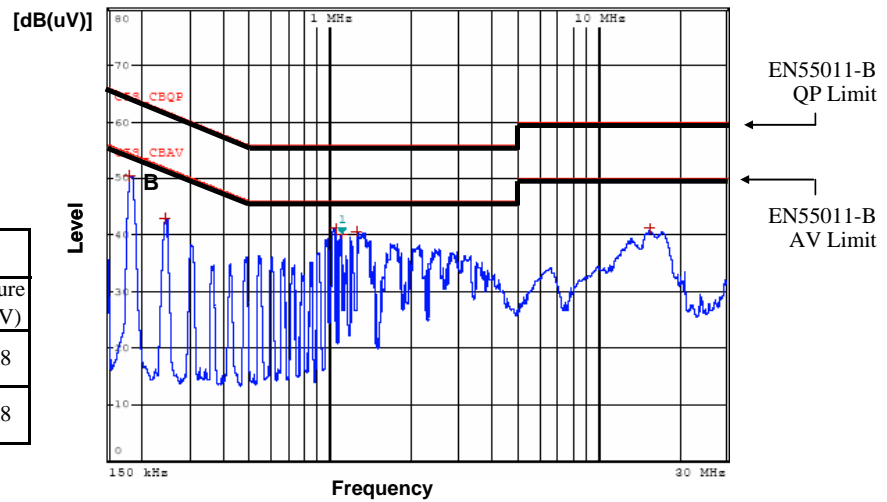

Phase : L

2-15 Electro-Magnetic Interference characteristics

Conditions: Vin : 115VAC
Iout : 100%

Conducted Emission

24V

Point A (17.127 MHz)		
Ref.	Limit	Measure
Data	(dB μ V)	(dB μ V)
QP	60.00	41.52
AV	50.00	34.75

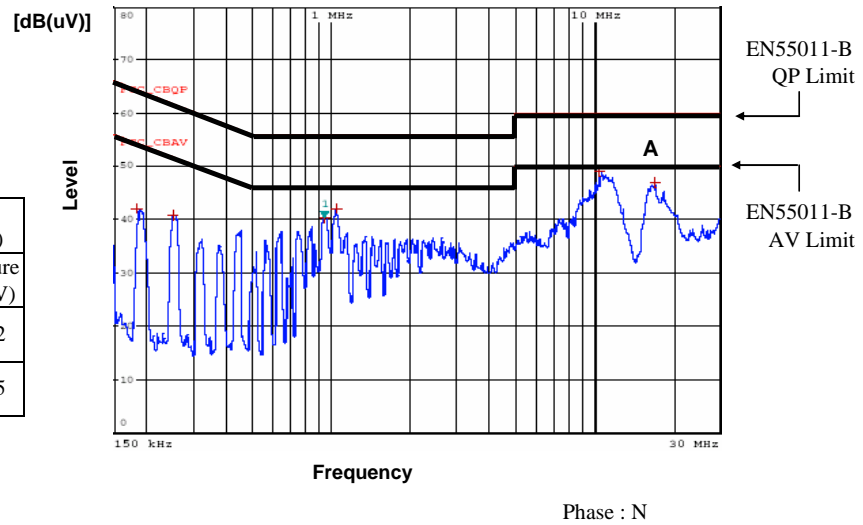

Point B (0.252 MHz)		
Ref.	Limit	Measure
Data	(dB μ V)	(dB μ V)
QP	61.69	41.75
AV	51.69	37.29

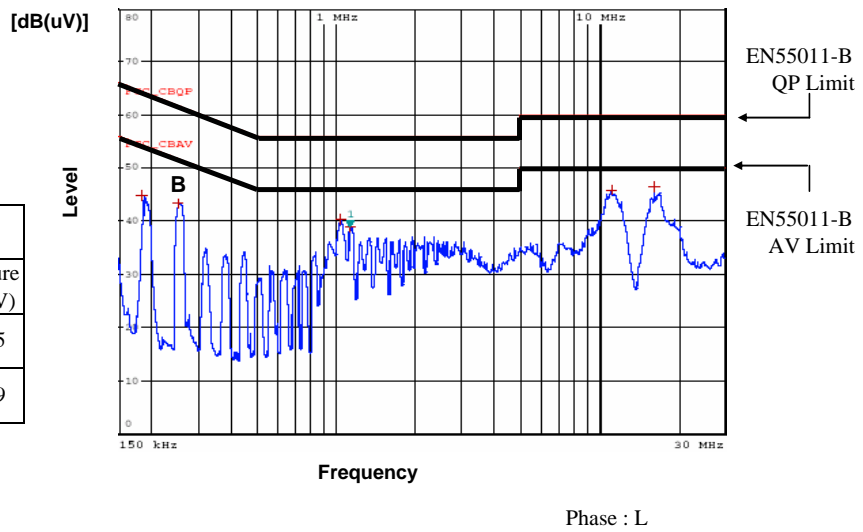

2-15 Electro-Magnetic Interference characteristics

Conditions: Vin : 230VAC
Iout : 100%

Conducted Emission

24V

Ref.	Point A (0.188MHz)	
	Data	Measure (dB μ V)
QP	64.12	43.04
AV	54.12	41.70

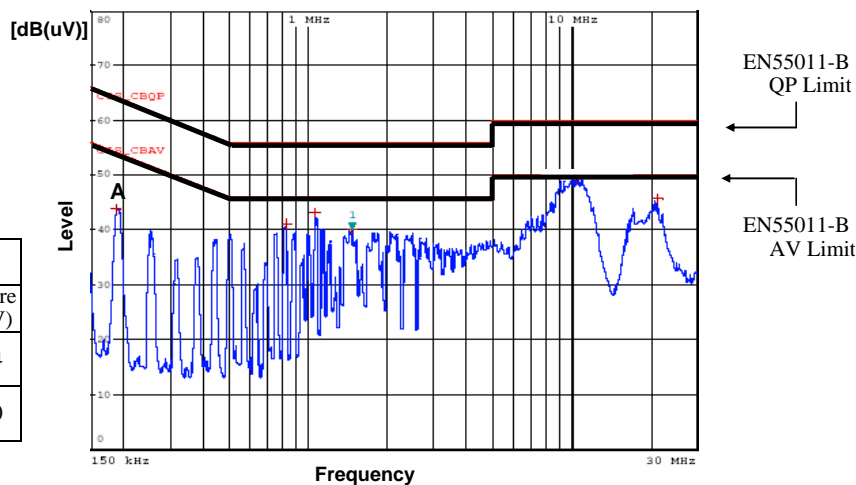

Phase : N

Ref.	Point B (0.190MHz)	
	Data	Measure (dB μ V)
QP	64.04	47.32
AV	54.04	43.76

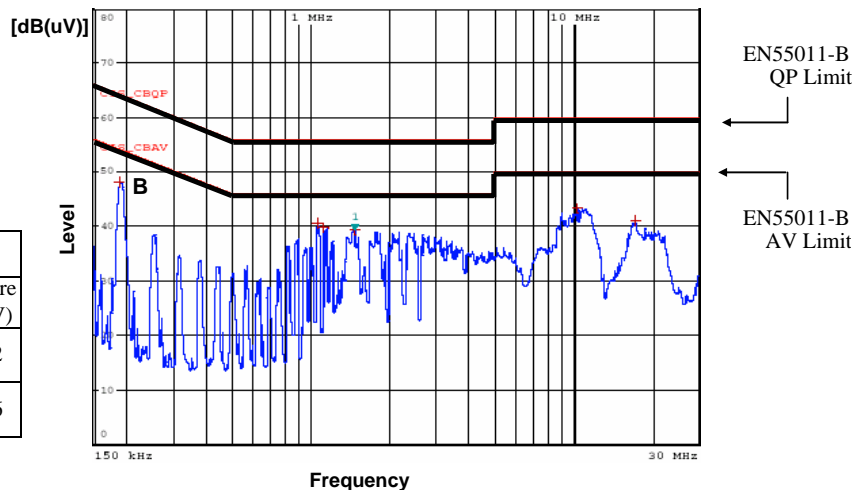

Phase : L

2-15 Electro-Magnetic Interference characteristics

Conditions: Vin : 115VAC
Iout : 100%

Radiated Emission

5V

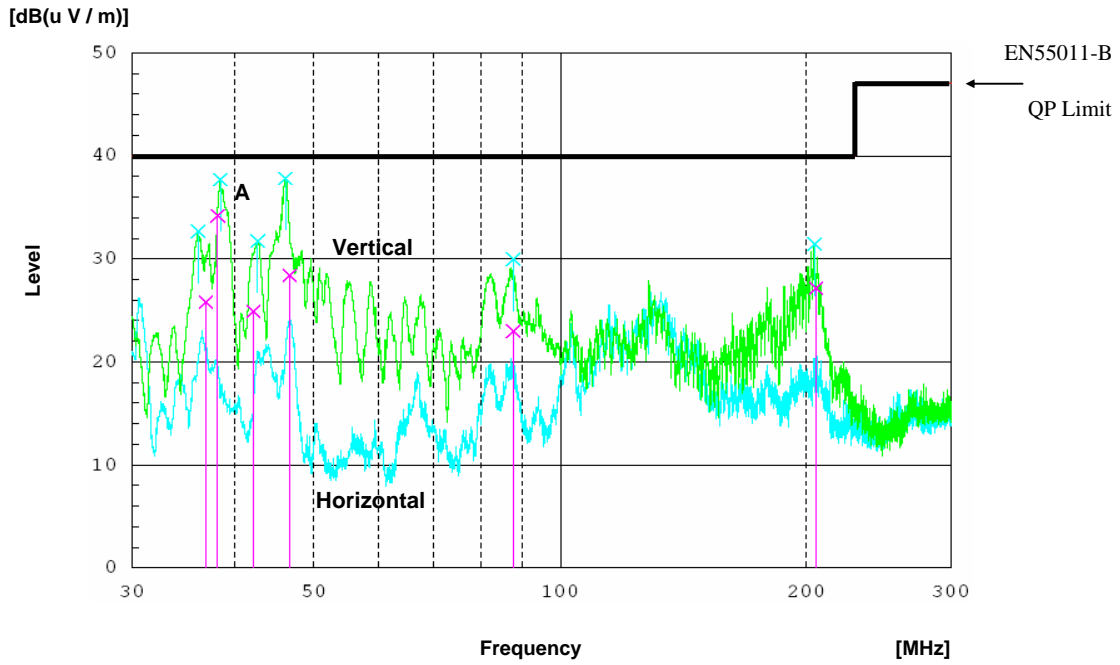

Point A (38.117MHz)		
Limit (dBmV/m)	Measure (dBmV/m)	(P)
40.0	34.2	V

2-15 Electro-Magnetic Interference characteristics

Conditions: Vin : 230VAC
Iout : 100%

Radiated Emission

5V

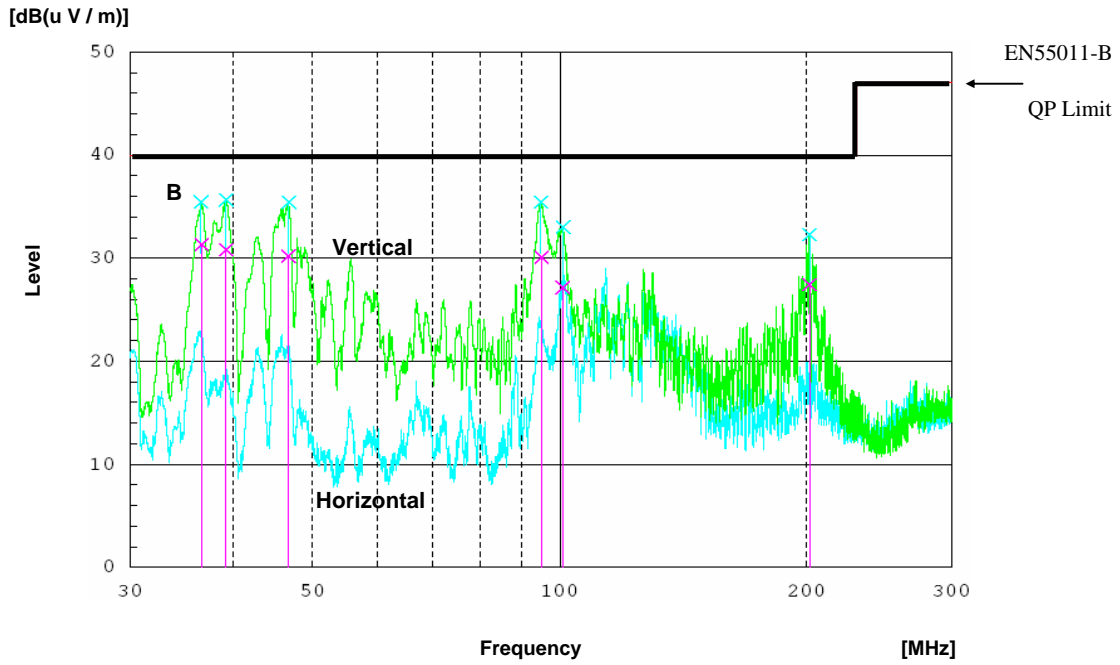

Point B (36.633MHz)		
Limit (dBmV/m)	Measure (dBmV/m)	(P)
40.0	31.4	V

2-15 Electro-Magnetic Interference characteristics

Conditions:

Vin : 115VAC

Iout : 100%

Radiated Emission

12V

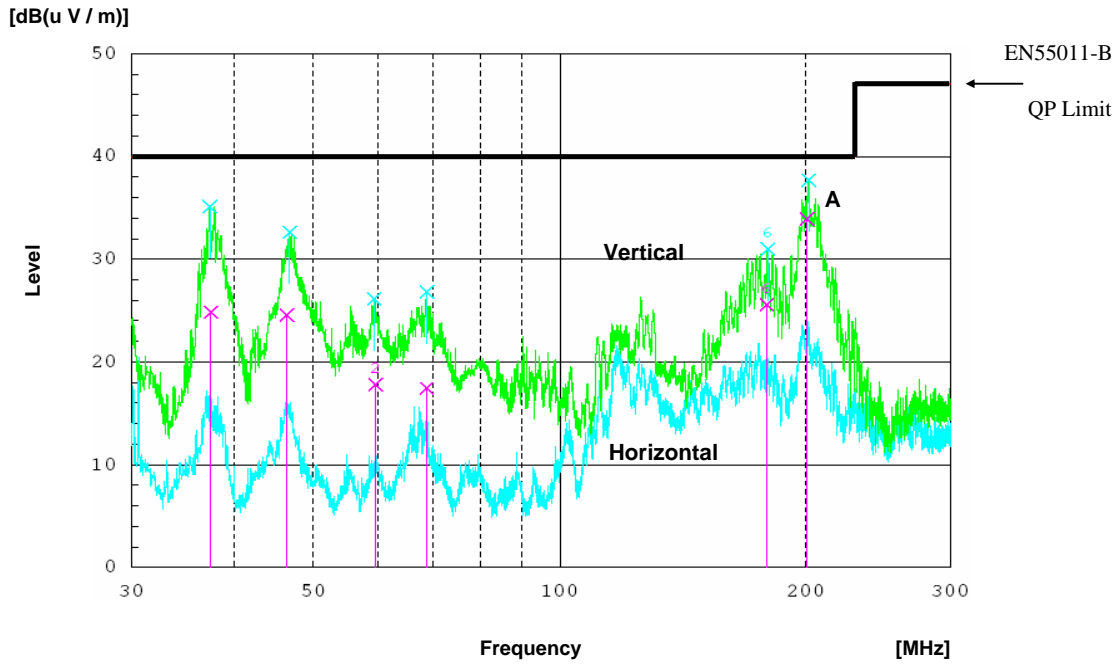

Point A (200.456MHz)		
Limit (dBmV/m)	Measure (dBmV/m)	(P)
40.0	34.0	V

2-15 Electro-Magnetic Interference characteristics

Conditions: Vin : 230VAC
Iout : 100%

Radiated Emission

12V

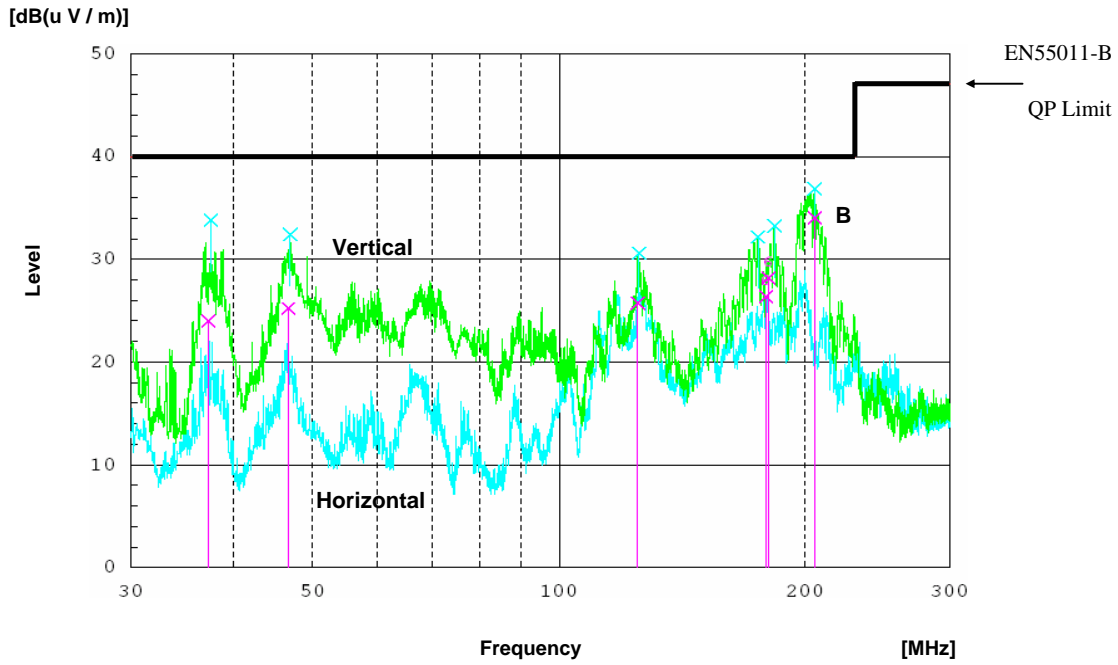

Point B (205.233MHz)		
Limit (dBmV/m)	Measure (dBmV/m)	(P)
40.0	34.0	V

2-15 Electro-Magnetic Interference characteristics

Conditions: Vin : 115VAC
Iout : 100%

Radiated Emission

24V

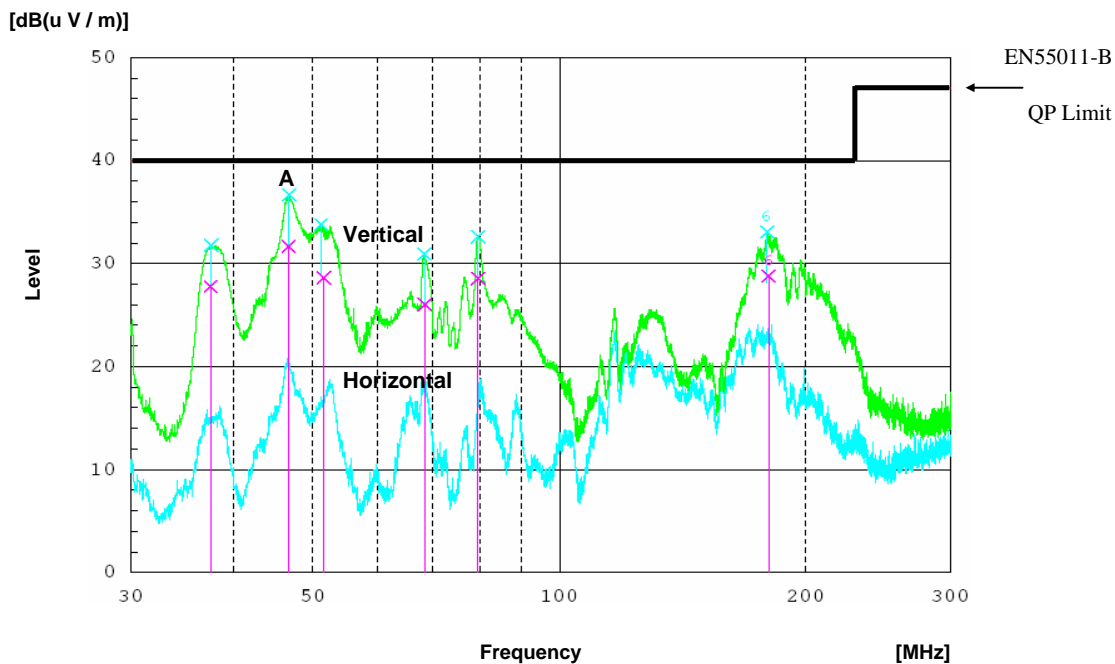

Point A (46.682MHz)		
Limit (dBmV/m)	Measure (dBmV/m)	(P)
40.0	31.7	V

2-15 Electro-Magnetic Interference characteristics

Conditions: Vin : 230VAC
Iout : 100%

Radiated Emission

24V

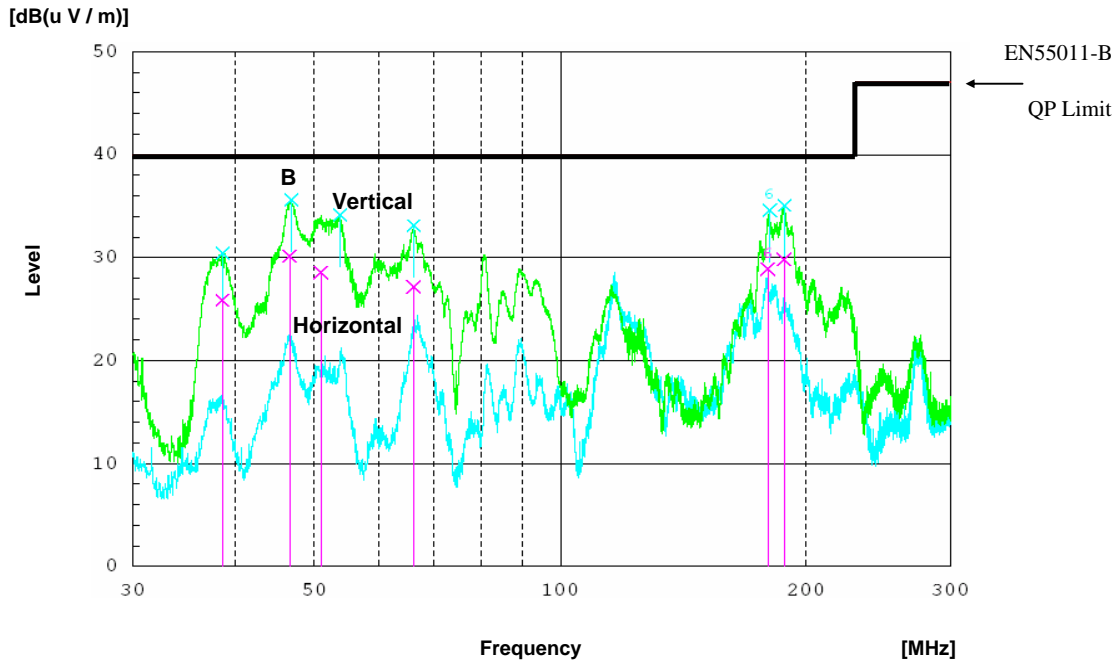

Point B (46.627MHz)		
Limit (dBmV/m)	Measure (dBmV/m)	(P)
40.0	30.2	V