

VS100E

EVALUATION DATA

型式データ

INDEX

1. 測定方法	Evaluation Method	PAGE
1.1 測定回路	Circuit used for determination	
測定回路 1	Circuit 1 used for determination	T-1
	静特性	Steady state data
	過電流保護特性	Over current protection (OCP) characteristics
	過電圧保護特性	Over voltage protection (OVP) characteristics
	出力立ち上がり特性	Output rise characteristics
	出力立ち下がり特性	Output fall characteristics
	出力保持時間特性	Hold up time characteristics
測定回路 2	Circuit 2 used for determination	T-1
	過渡応答（負荷急変）特性	Dynamic load response characteristics
測定回路 3	Circuit 3 used for determination	T-1
	入力サージ電流（突入電流）特性	Inrush current characteristics
測定回路 4	Circuit 4 used for determination	T-2
	リーク電流特性	Leakage current characteristics
測定回路 5	Circuit 5 used for determination	T-2
	出力リップル、ノイズ波形	Output ripple and noise waveform
測定構成	Configuration used for determination	T-2
	EMI特性 Electro-Magnetic Interference characteristics	
	雑音端子電圧（帰還ノイズ）	Conducted Emission Noise
	雑音電界強度（輻射ノイズ）	Radiated Emission Noise
1.2 使用測定機器	List of equipment used	T-3
2. 特性データ	Characteristics	
2.1 静特性	Steady state data	
(1) 入力・負荷・温度変動／出力起動・低下電圧	Regulation - line and load, Temperature drift / Start up voltage and Drop out voltage ...	T-4
(2) 効率対出力電流	Efficiency vs. Output current.....	T-5
(3) 入力電流対出力電流	Input current vs. Output current.....	T-6
(4) 入力電力対出力電流	Input power vs. Output current.....	T-7
2.2 過電流保護特性	Over current protection (OCP) characteristics	T-8
2.3 過電圧保護特性	Over voltage protection (OVP) characteristics	T-8
2.4 出力立ち上がり、立ち下がり特性	Output rise, Output fall characteristics	T-9
2.5 出力保持時間特性	Hold up time characteristics	T-10
2.6 過渡応答（負荷急変）特性	Dynamic load response characteristics	T-11
2.7 入力電圧瞬停特性	Response to brown out characteristics	T-12
2.8 入力サージ電流（突入電流）特性	Inrush current waveform	T-13
2.9 リーク電流特性	Leakage current characteristics	T-13
2.10 出力リップル、ノイズ波形	Output ripple and noise waveform	T-14
2.11 EMI 特性	Electro-Magnetic Interference characteristics	T-15～16
使用記号	Terminology used	
	Definition	
Vin 入力電圧	Input voltage
Vout 出力電圧	Output voltage
Iin 入力電流	Input current
Iout 出力電流	Output current
Ta 周囲温度	Ambient temperature
f 周波数	Frequency

1. 測定方法 Evaluation Method

1.1 測定回路 Circuit used for determination

測定回路1 Circuit 1

- | | |
|-------------|---|
| • 静特性 | Steady state data |
| • 過電流保護特性 | Over current protection (OCP) characteristics |
| • 過電圧保護特性 | Over voltage protection (OVP) characteristics |
| • 出力立ち上がり特性 | Output rise characteristics |
| • 出力立ち下がり特性 | Output fall characteristics |
| • 出力保持時間特性 | Hold up time characteristics |

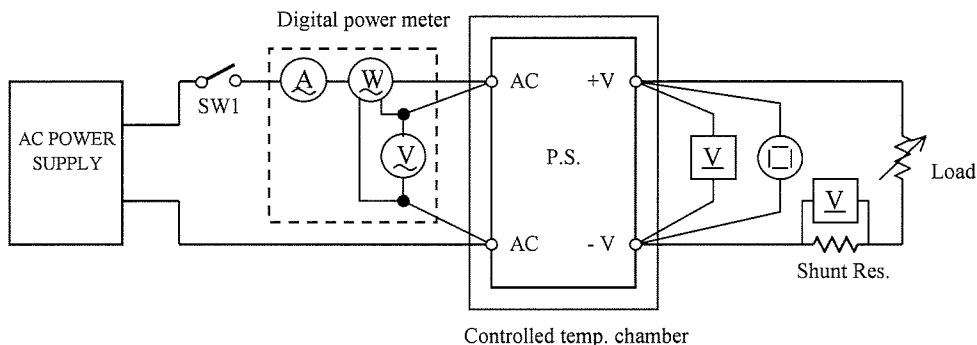

測定回路2 Circuit 2

- 過渡応答(負荷急変)特性 Dynamic load response characteristics

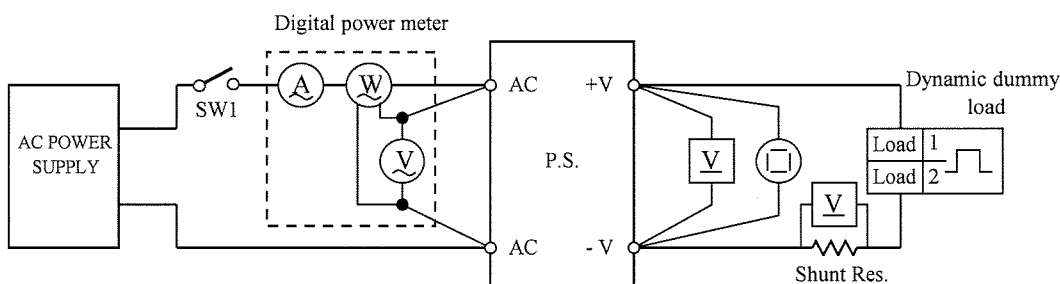

Output current waveform
Iout 50% <=> 100%

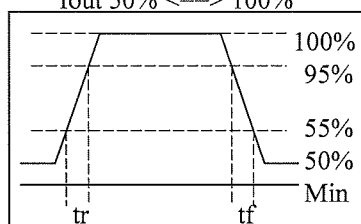

測定回路3 Circuit 3

- 入力サージ電流(突入電流)特性 Inrush current characteristics

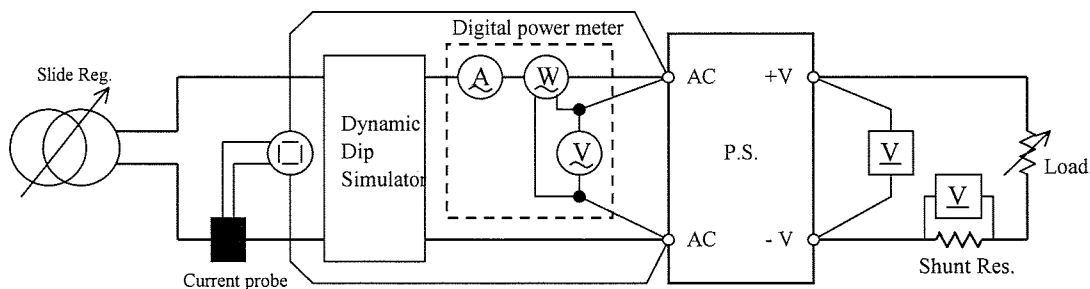

測定回路4 Circuit 4

・リーク電流特性

Leakage current characteristics

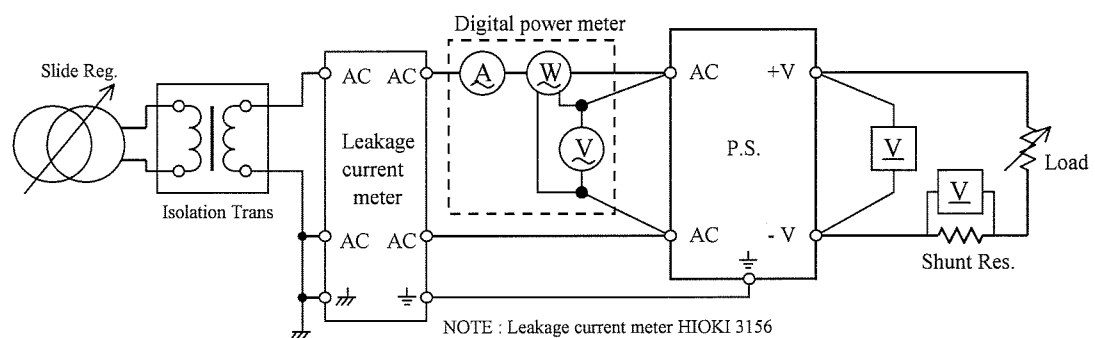

測定回路5 Circuit 5

・出力リップル、ノイズ特性

Output ripple and noise waveform

Normal Mode (JEITA Standard RC-9131A)

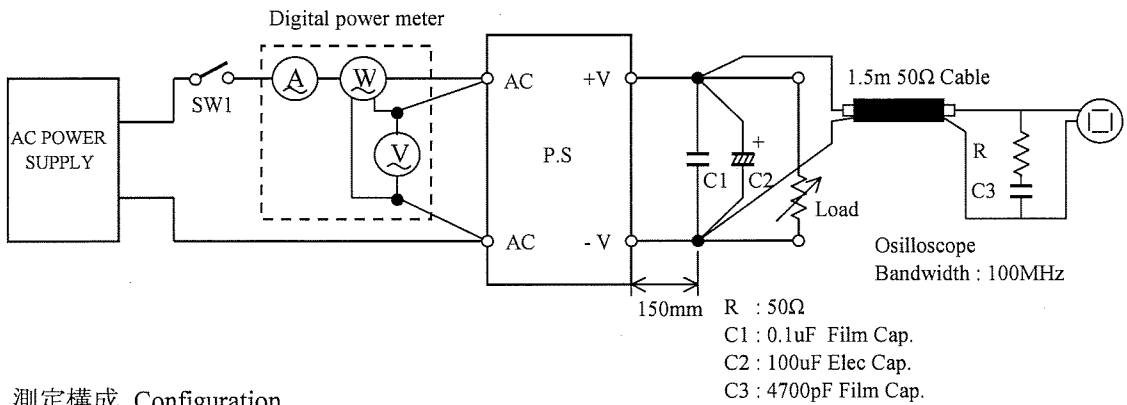

測定構成 Configuration

・EMI特性

Electro-Magnetic Interference characteristics

雑音端子電圧 (帰還ノイズ)

Conducted Emission Noise

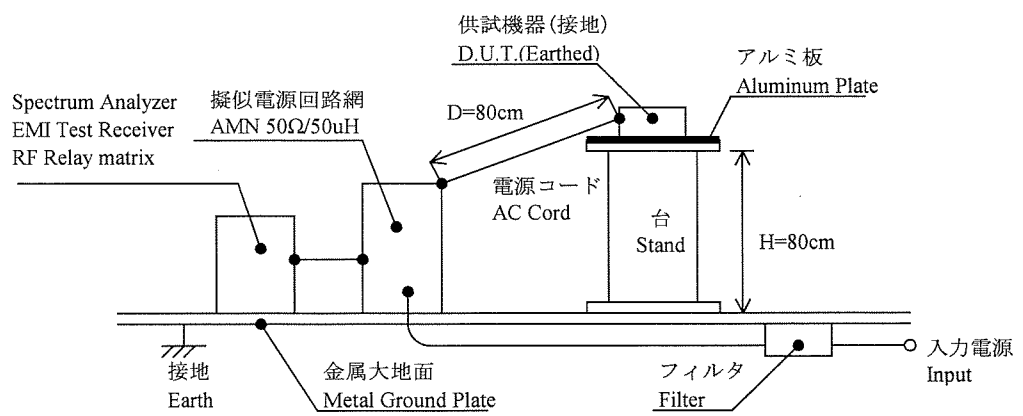

雑音電界強度 (輻射ノイズ)

Radiated Emission Noise

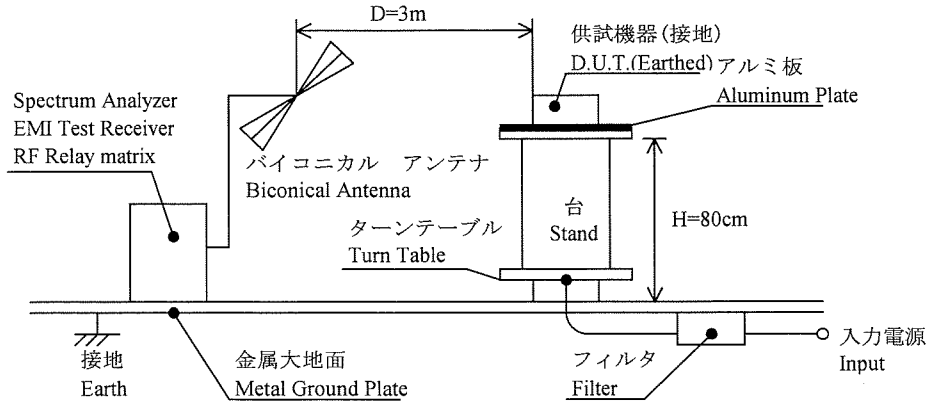

1.2 使用測定機器 List of equipment used

	EQUIPMENT USED	MANUFACTURER	MODEL NO.
1	DIGITAL STORAGE OSCILLOSCOPE	TEKTRONIX	TDS3012
2	DIGITAL STORAGE OSCILLOSCOPE	YOKOGAWA ELECT.	DL1740EL/DL9040L
3	DIGITAL MULTIMETER	AGILENT	34970A
4	DIGITAL POWER METER	YOKOGAWA ELECT.	WT210
5	CURRENT PROBE/AMPLIFIER	YOKOGAWA ELECT.	701930
6	DYNAMIC DUMMY LOAD	TAKASAGO	FK-600L
7	SLIDE REGULATOR	MATSUNAGA	SD-2650
8	CVCF	TAKASAGO	AA2000XG
9	LEAKAGE CURRENT METER	HIOKI	3156
10	DYNAMIC DIP SIMULATOR	CYBERNETICS	PSA-210
11	CONTROLLED TEMP. CHAMBER	ESPEC	SU-261
12	SPECTRUM ANALYZER	ROHDE & SCHWARZ	FSA
13	EMI TEST RECEIVER	ROHDE & SCHWARZ	ESHS10
14	EMI TEST RECEIVER	ROHDE & SCHWARZ	ESVS10
15	RF RELAY MATRIX	ROHDE & SCHWARZ	PSU
16	AMN	KYORITU DENSHI	KNW-242
17	ANTENA(BICONICAL ANTENA)	SCHWARZBECK	BBA9106
18	POWER HITESTER	HIOKI	3193
19	POWER HITESTER	HIOKI	9600
20	IMPEDANCE NETWORK 20A	NF	4150
21	SING PHASE MASTER	NF	4420
22	BOOSTER	NF	4421

2.1 静特性 Steady state data

(1) 入力・負荷・温度変動／出力起動・低下電圧

Regulation - line and load, Temperature drift / Start up voltage and Drop out voltage

5V

1. Regulation - line and load Condition Ta : 25 °C

Iout \ Vin	85VAC	100VAC	132VAC	line regulation	
0%	5.006V	5.007V	5.007V	1mV	0.020%
50%	5.006V	5.006V	5.007V	1mV	0.020%
100%	5.006V	5.006V	5.007V	1mV	0.020%
load regulation	0mV	1mV	0mV		
	0.000%	0.020%	0.000%		

2. Temperature drift

Conditions

Vin : 100 VAC

Iout : 100 %

Ta	-10°C	+25°C	+50°C	temperature stability	
Vout	5.006V	5.006V	5.002V	4mV	0.080%

3. Start up voltage and Drop out voltage

Conditions

Ta : 25 °C

Iout : 100 %

Start up voltage (Vin)	70VAC
Drop out voltage (Vin)	69VAC

12V

1. Regulation - line and load Condition Ta : 25 °C

Iout \ Vin	85VAC	100VAC	132VAC	line regulation	
0%	11.967V	11.967V	11.967V	0mV	0.000%
50%	11.966V	11.966V	11.966V	0mV	0.000%
100%	11.966V	11.966V	11.966V	0mV	0.000%
load regulation	1mV	1mV	1mV		
	0.008%	0.008%	0.008%		

2. Temperature drift

Conditions

Vin : 100 VAC

Iout : 100 %

Ta	-10°C	+25°C	+50°C	temperature stability	
Vout	11.979V	11.966V	11.945V	34mV	0.283%

3. Start up voltage and Drop out voltage

Conditions

Ta : 25 °C

Iout : 100 %

Start up voltage (Vin)	69VAC
Drop out voltage (Vin)	65VAC

24V

1. Regulation - line and load Condition Ta : 25 °C

Iout \ Vin	85VAC	100VAC	132VAC	line regulation	
0%	23.982V	23.982V	23.982V	0mV	0.000%
50%	23.980V	23.981V	23.981V	1mV	0.004%
100%	23.981V	23.981V	23.981V	0mV	0.000%
load regulation	2mV	1mV	1mV		
	0.008%	0.004%	0.004%		

2. Temperature drift

Conditions

Vin : 100 VAC

Iout : 100 %

Ta	-10°C	+25°C	+50°C	temperature stability	
Vout	24.005V	23.981V	23.950V	55mV	0.229%

3. Start up voltage and Drop out voltage

Conditions

Ta : 25 °C

Iout : 100 %

Start up voltage (Vin)	69VAC
Drop out voltage (Vin)	68VAC

(2) 効率対出力電流

Efficiency vs. Output current

Conditions Vin : 85 VAC -----
 : 100 VAC - - - - -
 : 132 VAC ————
 Ta : 25 °C

5V

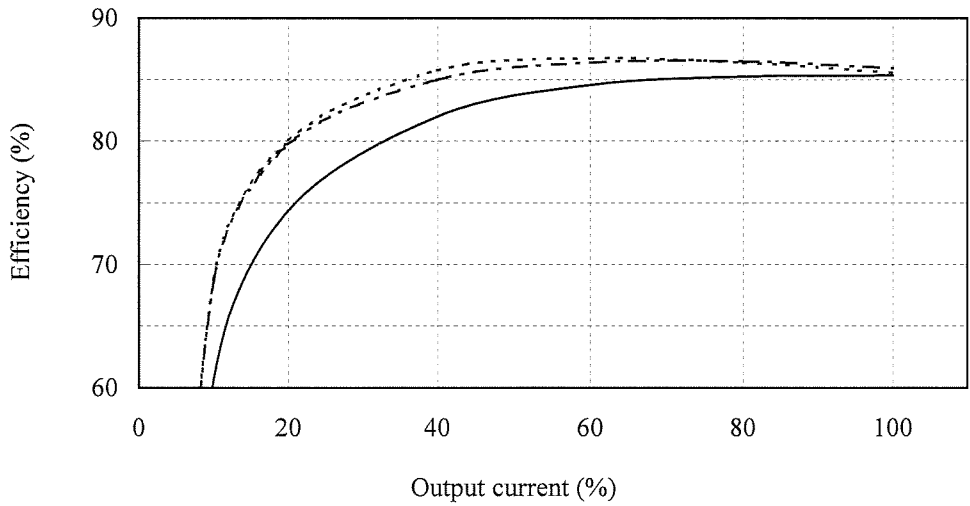

12V

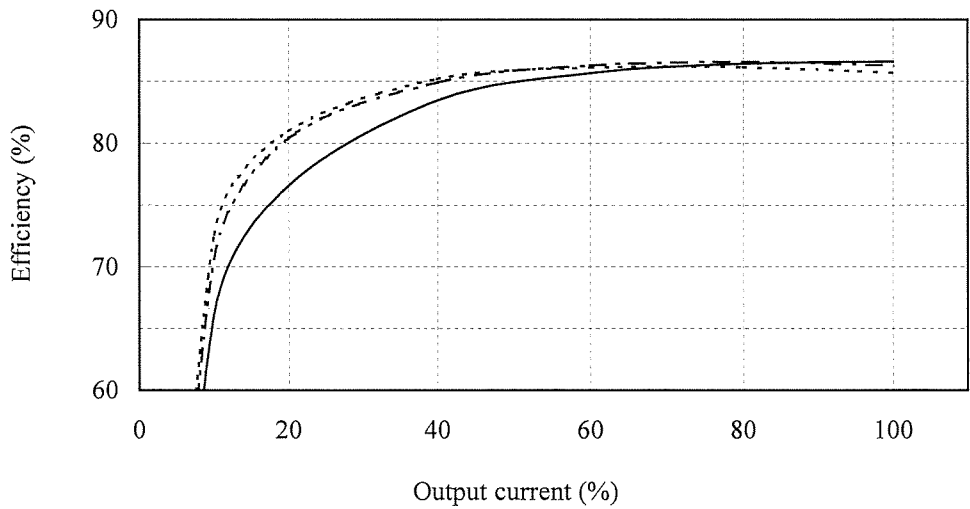

24V

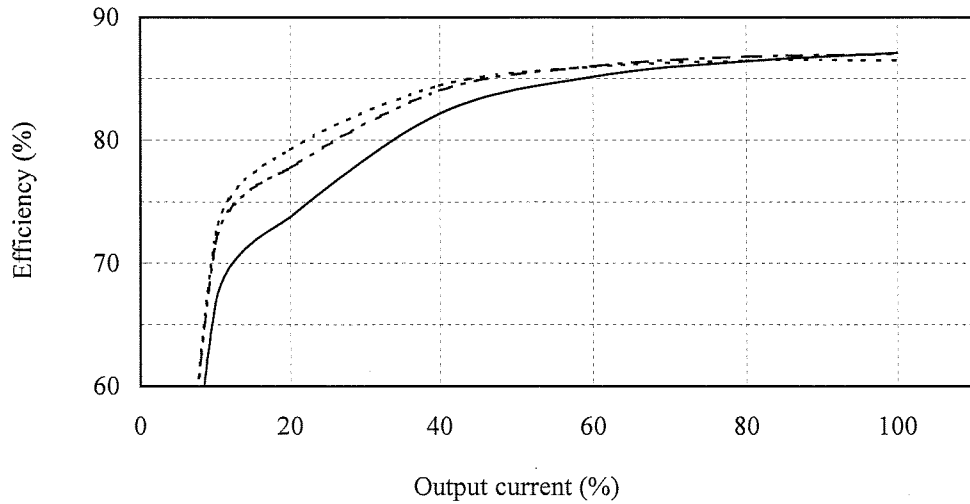

(3) 入力電流対出力電流
Input current vs. Output current

Conditions Vin : 85 VAC -----
 : 100 VAC - - - - -
 : 132 VAC ————
 Ta : 25 °C

5V

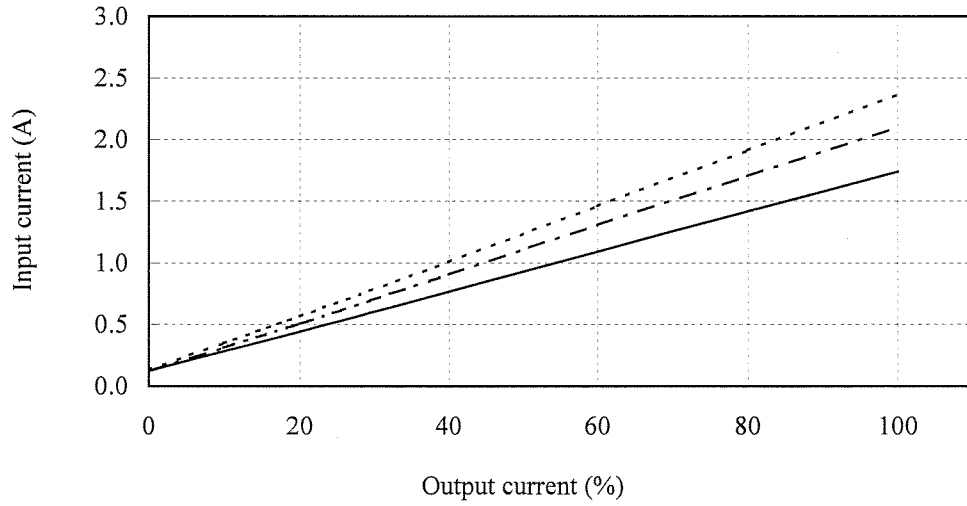

12V

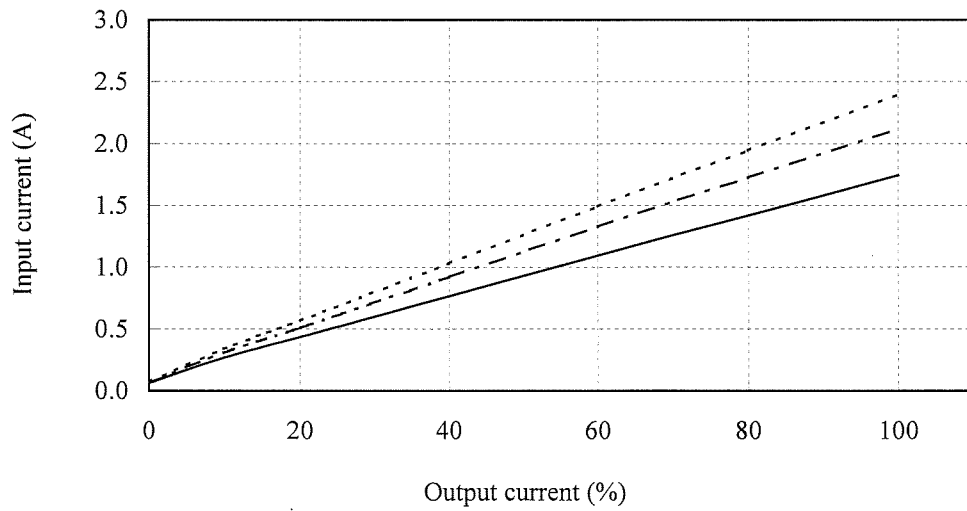

24V

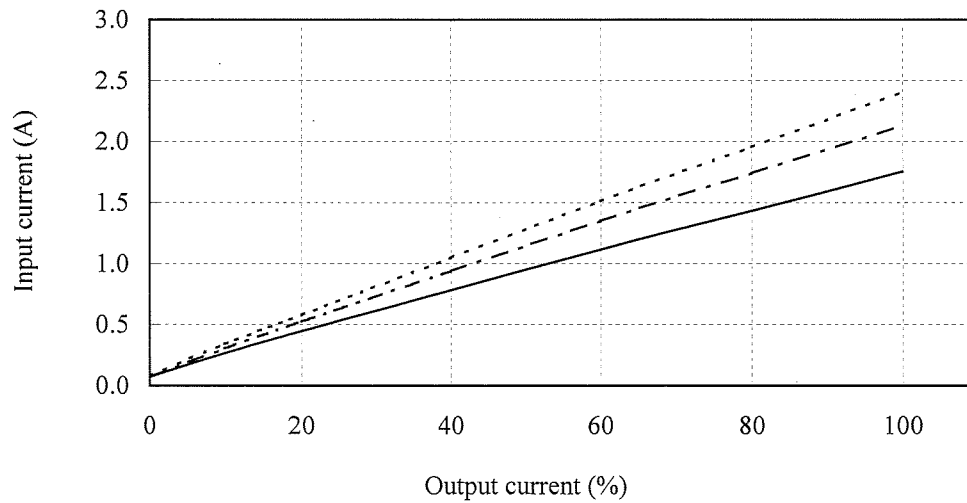

(4) 入力電力対出力電流
Low load input power vs. Output current

Conditions Vin : 85 VAC -----
: 100 VAC - - - - -
: 132 VAC ————
Ta : 25 °C

5V

Conditions Iout : 0%	
Vin	Input power
85VAC	4.8W
100VAC	4.9W
132VAC	6.3W

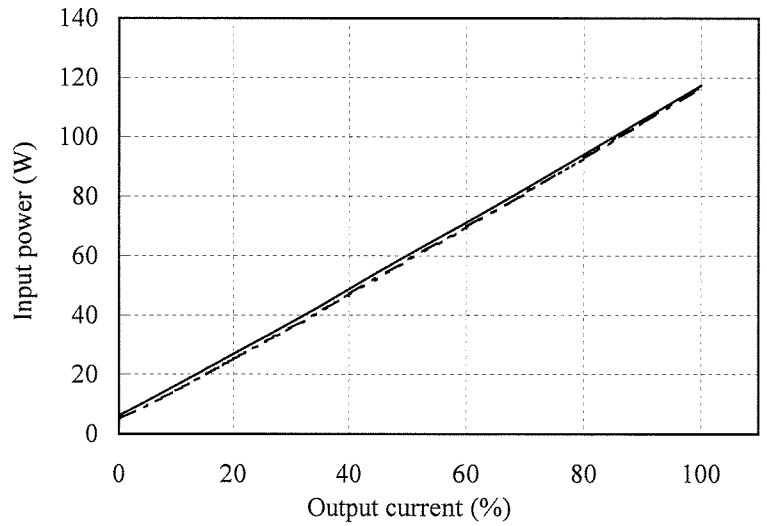

12V

Conditions Iout : 0%	
Vin	Input power
85VAC	2.3W
100VAC	2.0W
132VAC	2.5W

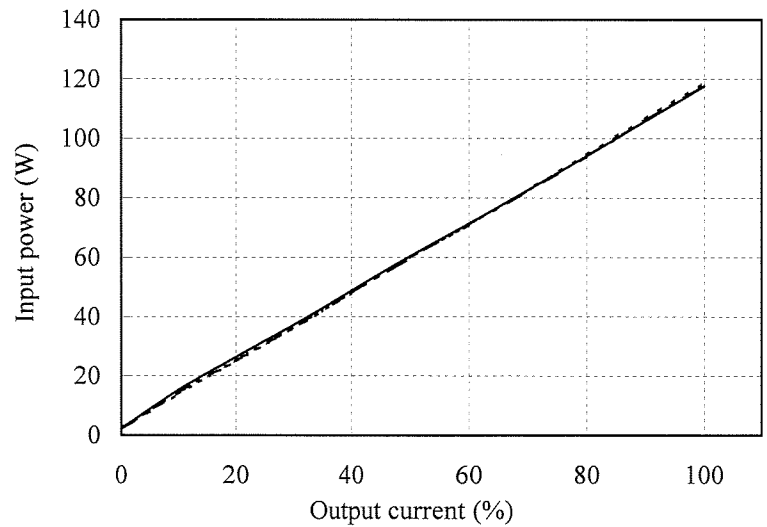

24V

Conditions Iout : 0%	
Vin	Input power
85VAC	2.5W
100VAC	2.4W
132VAC	3.0W

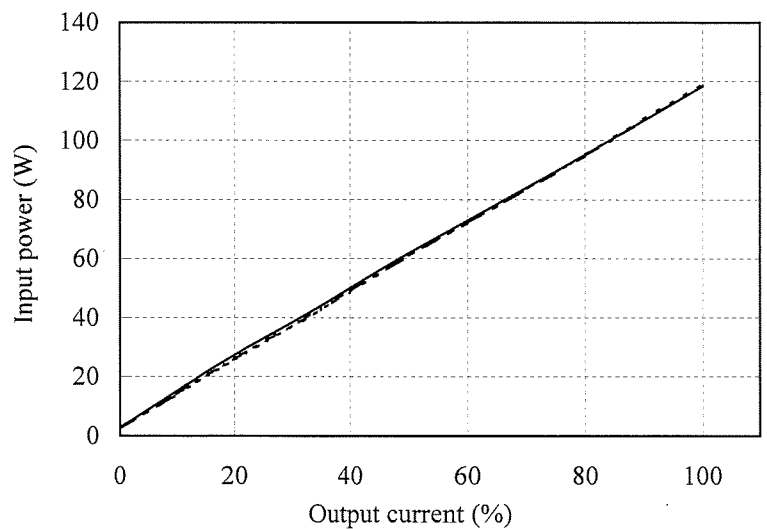

2.2 過電流保護特性

Over current protection (OCP) characteristics

2.3 過電圧保護特性

Over voltage protection (OVP) characteristics

Conditions Vin : 85 VAC -----
 100 VAC - - - - -
 132 VAC ————
 Ta : 25 °C

Conditions Vin : 100 VAC
 Io : 0 %
 Ta : 25 °C

5V

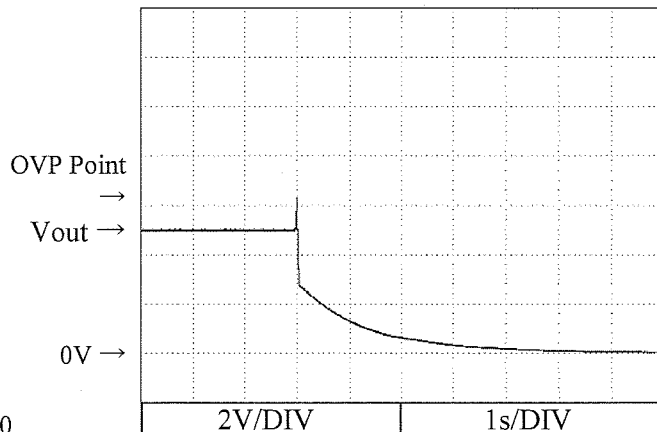
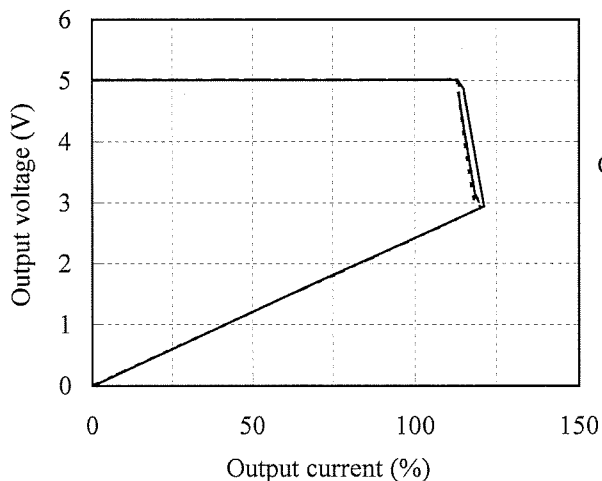

12V

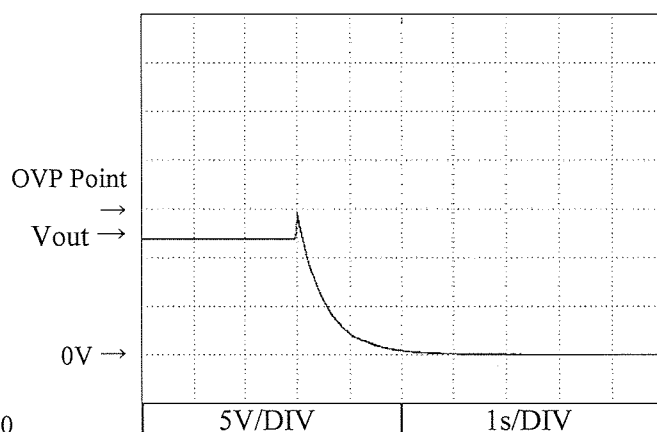
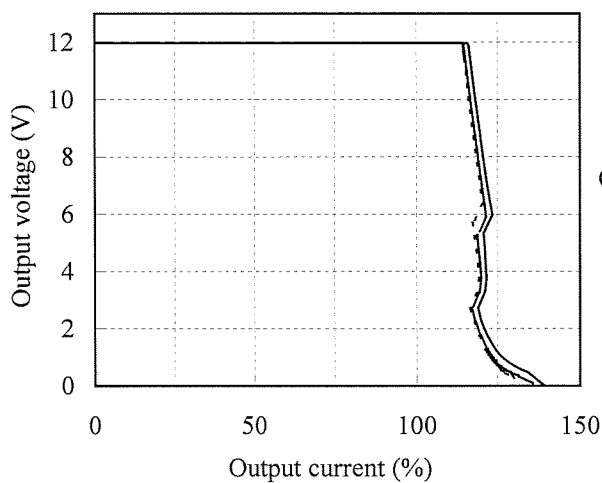

24V

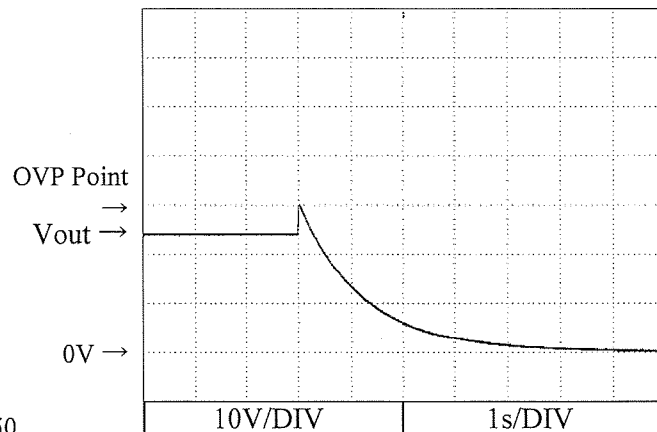
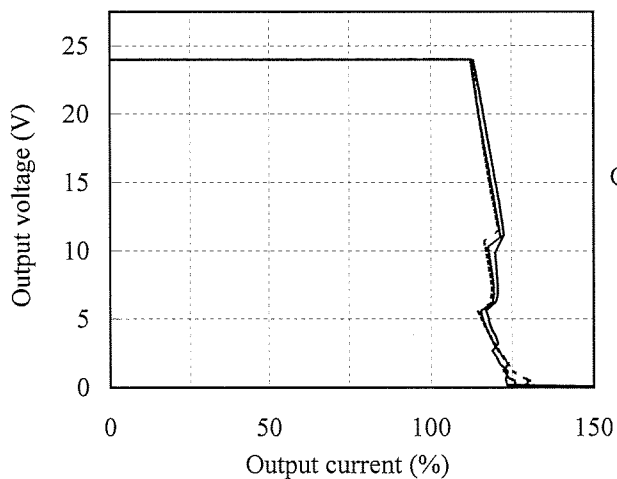

2.4 出力立ち上がり特性、出力立ち下がり特性

Output rise characteristics, Output fall characteristics

Conditions Vin : 85 VAC (A)
 100 VAC (B)
 132 VAC (C)
 Iout : 100 %
 Ta : 25 °C

5V

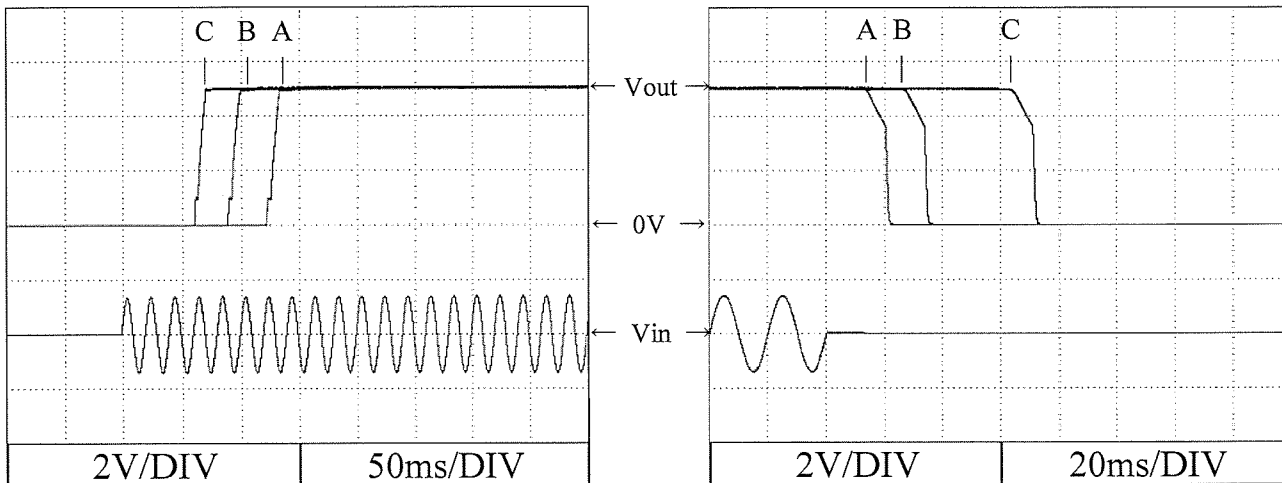

12V

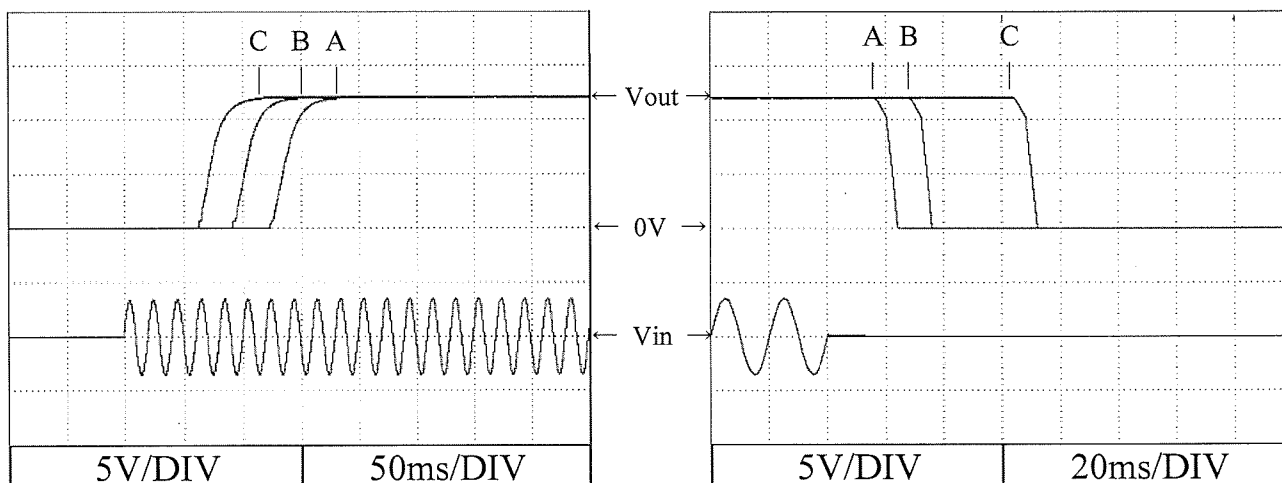

24V

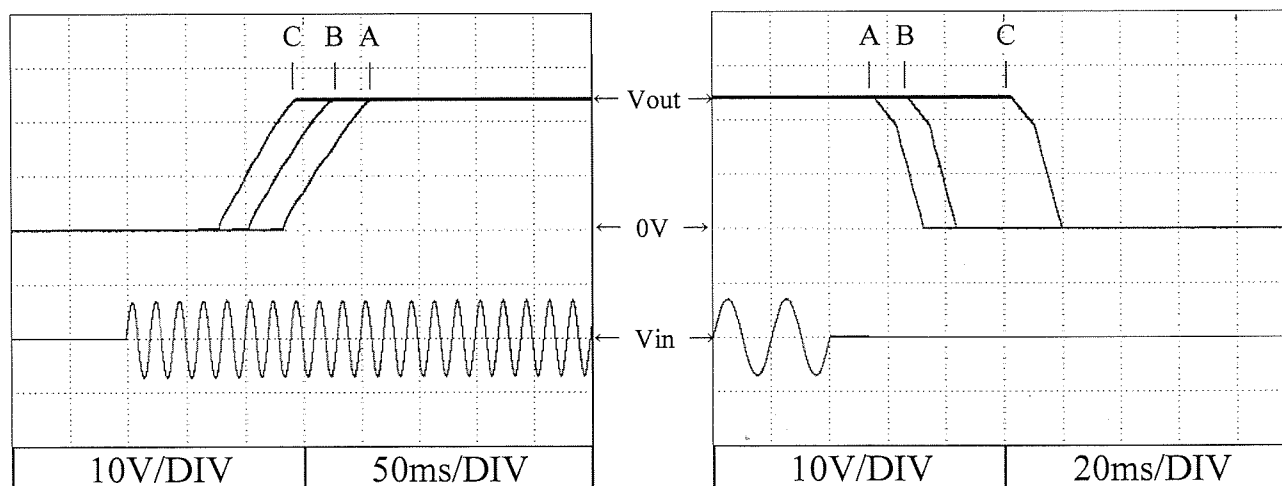

2.5 出力保持時間特性
Hold up time characteristics

Conditions V_{in} : 100 VAC
 T_a : 25 °C

5V

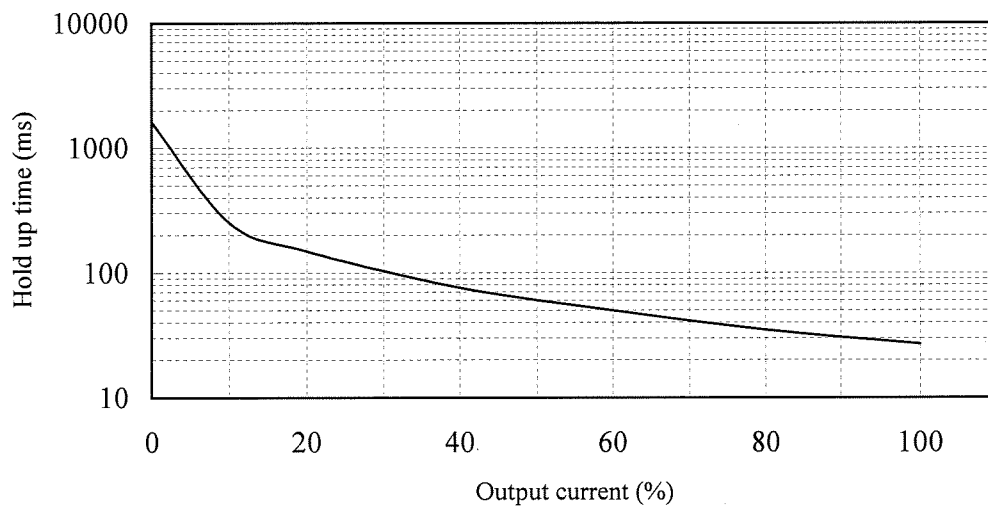

12V

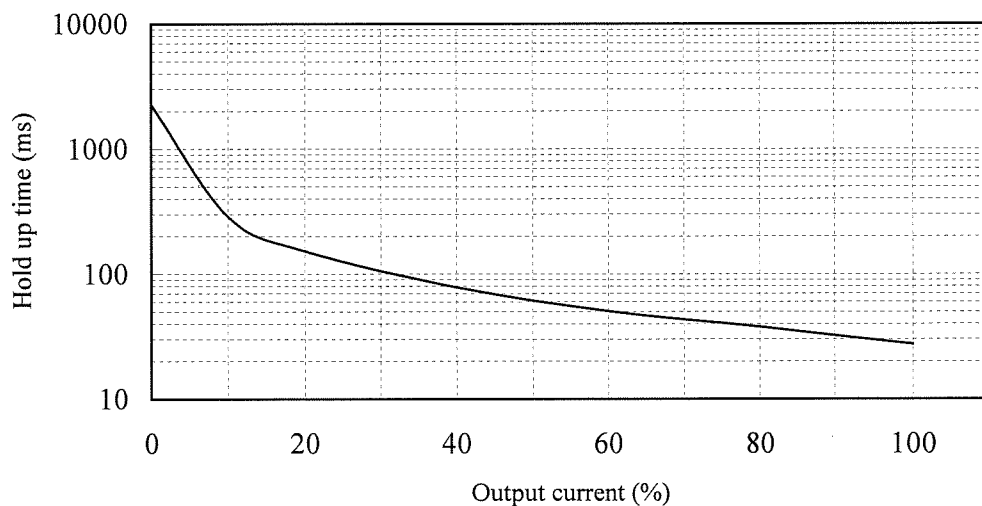

24V

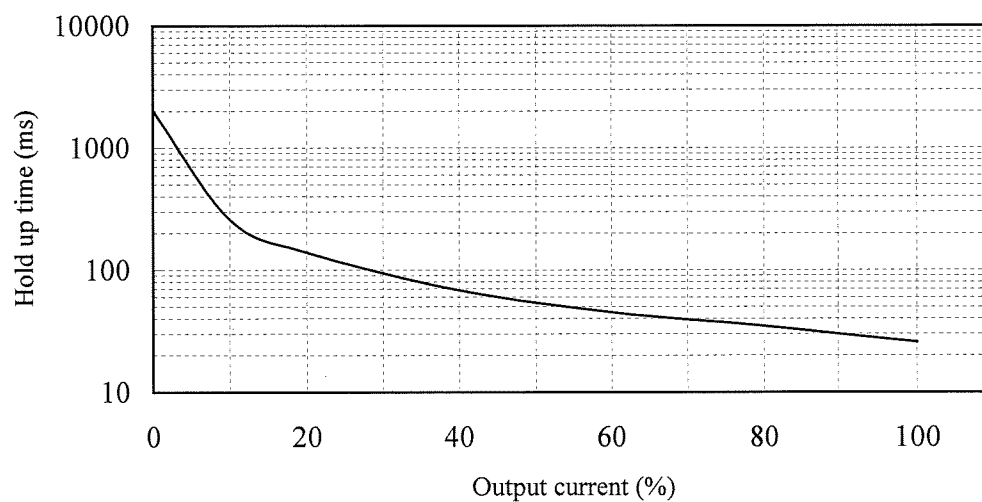

2.6 過渡応答 (負荷急変) 特性

Dynamic load response characteristics

Conditions Vin : 100 VAC
 Io : 50 % ↔ 100 %
 (tr = tf = 50us)
 Ta : 25 °C

f = 100Hz

f = 1kHz

5V

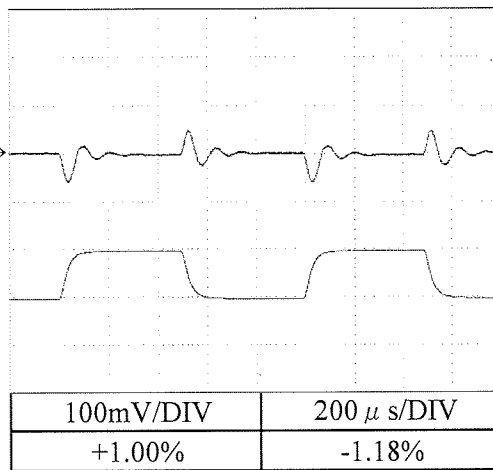
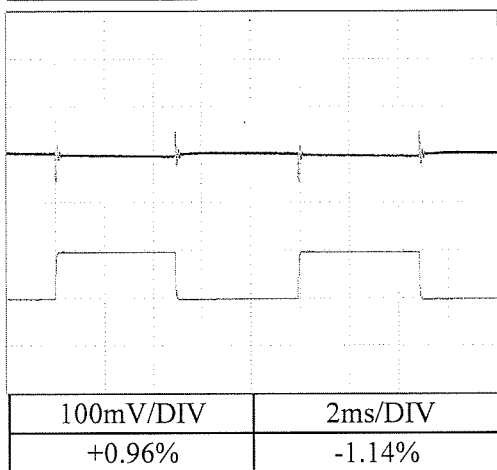

12V

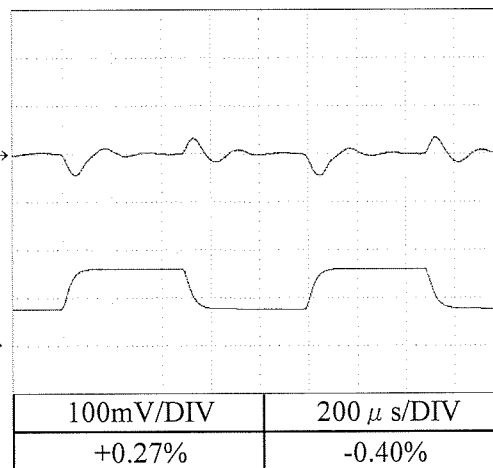
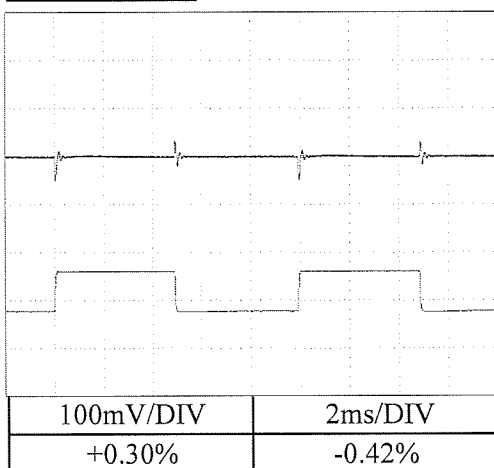

24V

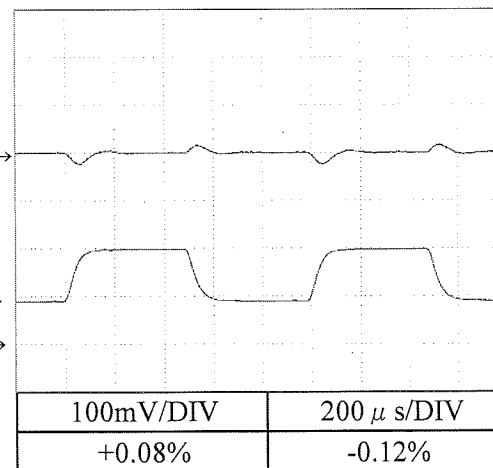
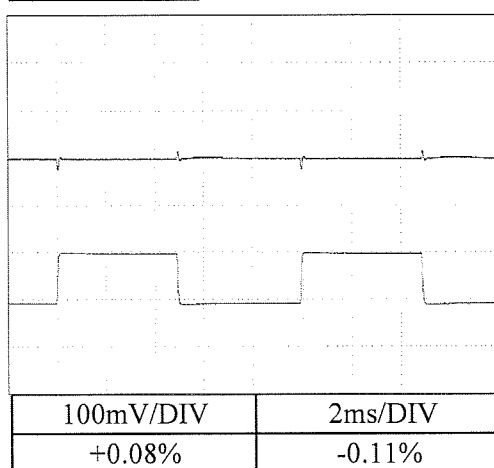

2.7 入力電圧瞬停特性

Response to brown out characteristics

Conditions Vin : 100 VAC
Iout : 100 %
Ta : 25 °C

5V

A = 27ms
B = 36ms
C = 37ms

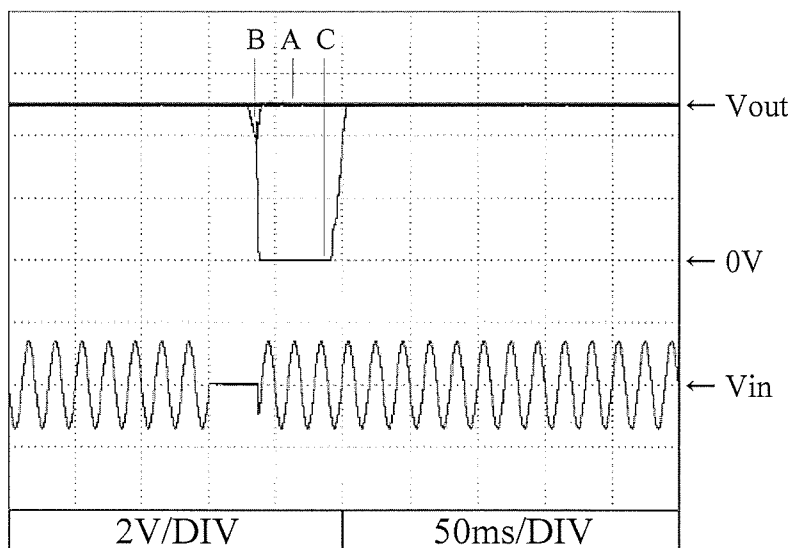

12V

A = 27ms
B = 34ms
C = 35ms

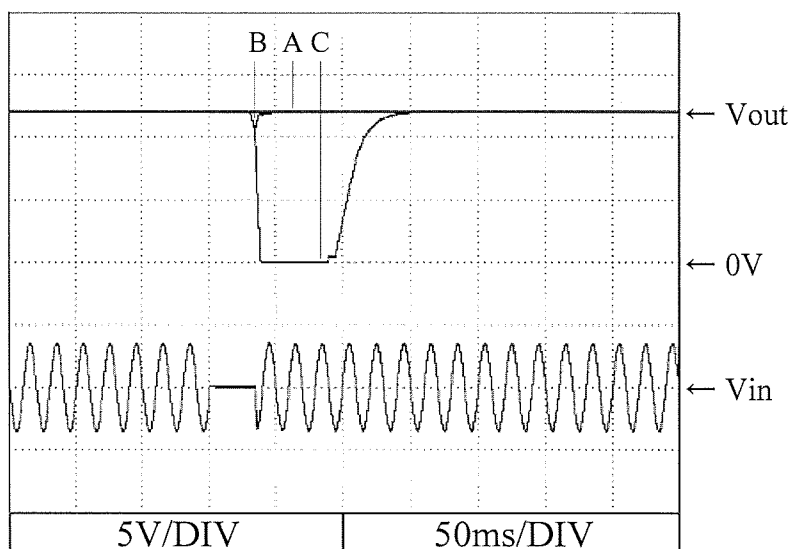

24V

A = 27ms
B = 36ms
C = 37ms

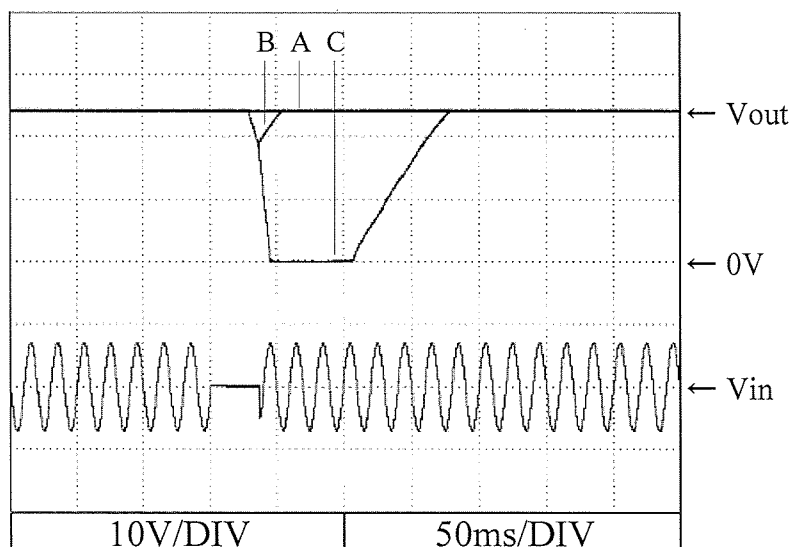

2.8 入力サージ電流 (突入電流) 特性
Inrush current waveform

Conditions Vin : 100 VAC
Iout : 100 %
Ta : 25 °C

5V

Switch on phase angle of input AC voltage
 $\phi = 0^\circ$

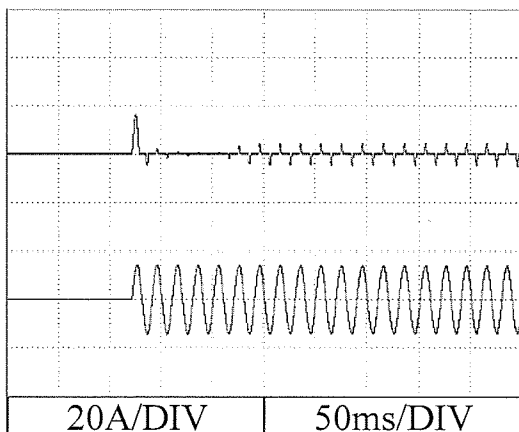

Switch on phase angle of input AC voltage
 $\phi = 90^\circ$

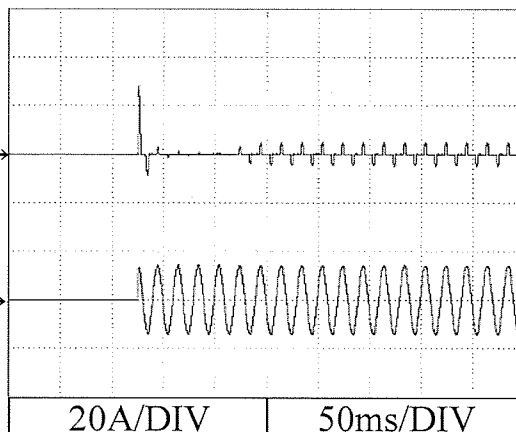

2.9 リーク電流特性
Leakage current characteristics

Conditions Iout : 0 % -----
100 % ————
Ta : 25 °C
f : 50 Hz
Equipment used : 3156 (HIOKI)

5V

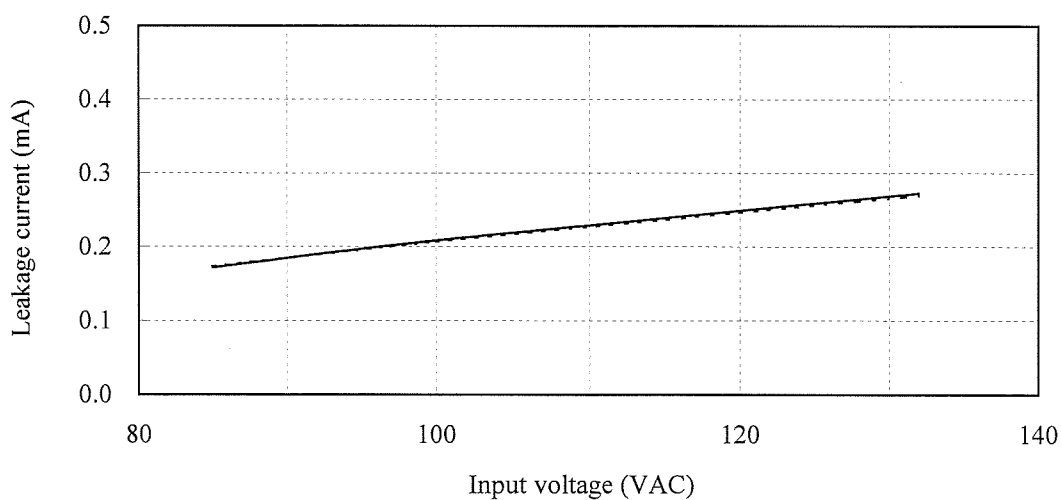

2.10 出力リップル、ノイズ波形
Output ripple and noise waveform

Conditions Vin : 100 VAC
Iout : 100 %
Ta : 25 °C

NORMAL MODE

5V

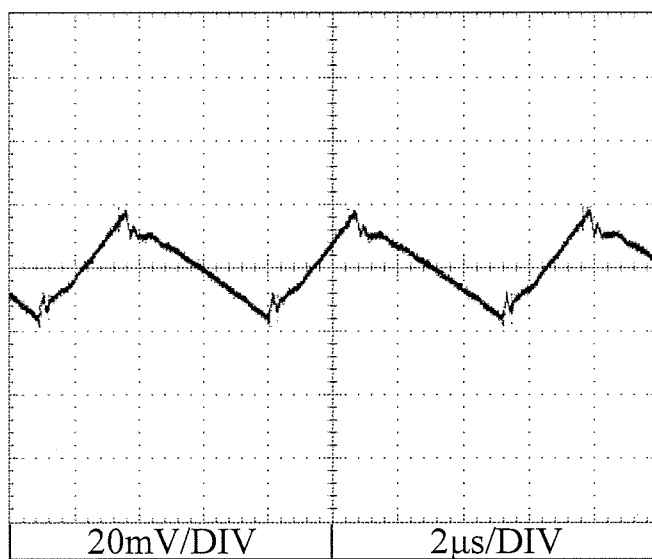

12V

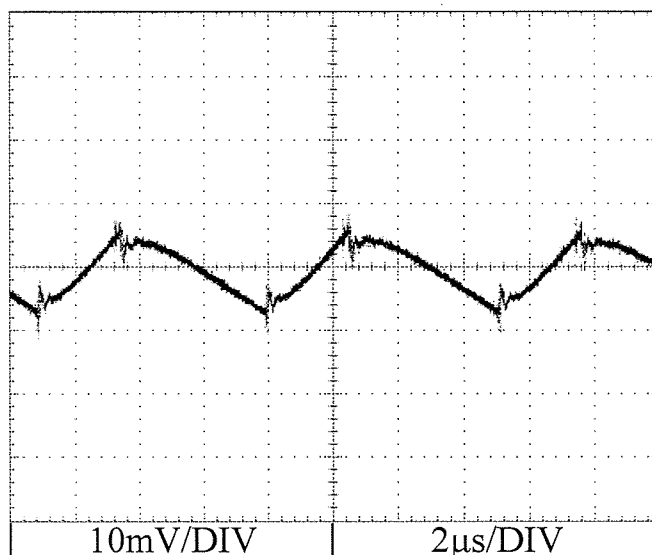

24V

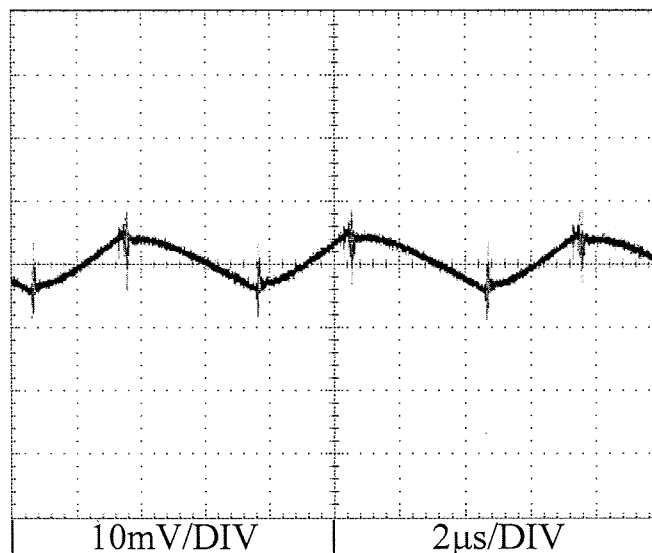

2.11 EMI 特性

Electro-Magnetic Interference characteristics

雑音端子電圧

Conducted Emission

Conditions

Vin : 100 VAC

Io : 100 %

Phase : N

Phase : L

5V

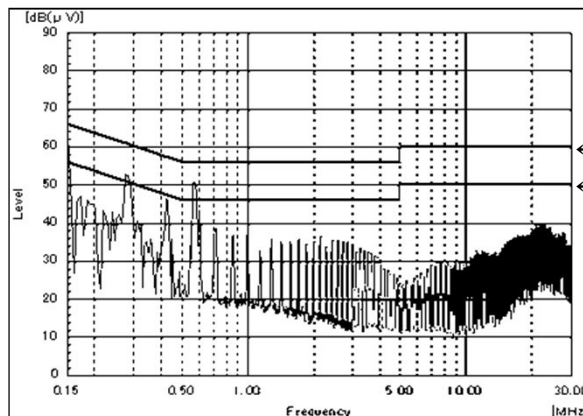
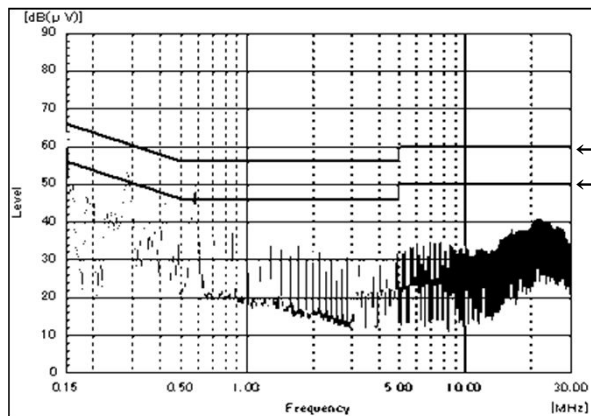

12V

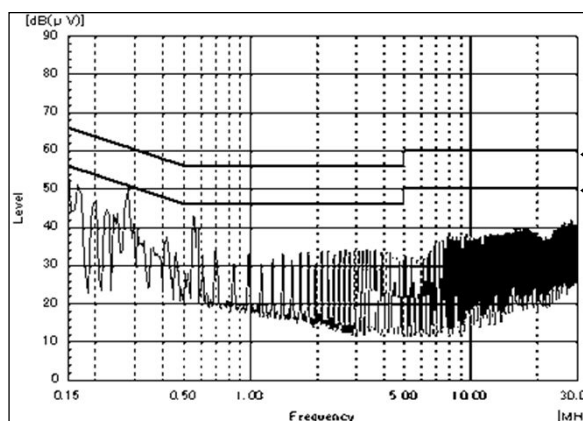
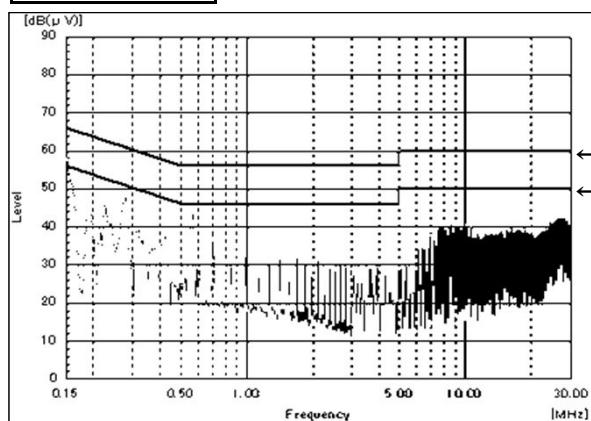

24V

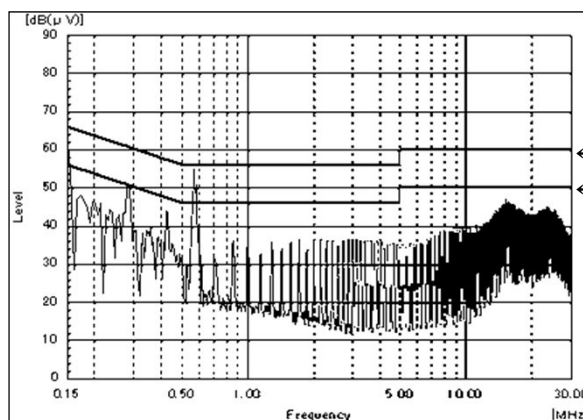
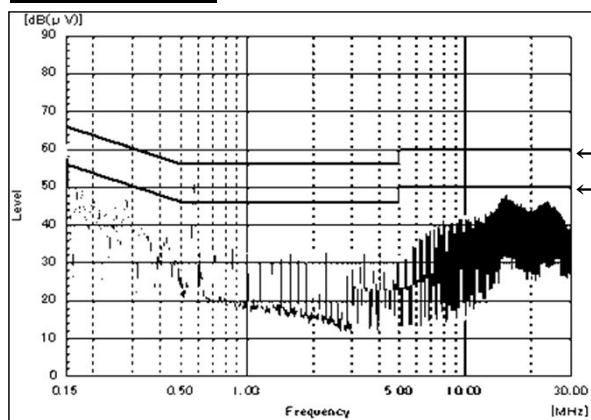

EN55011-B,EN55032-Bの限界値はVCCI class Bの限界値と同じ
Limit of EN55011-B,EN55032-B are same as its VCCI class B.

表示はピーク値です。
Indication is peak values.

雑音電界強度
Radiated Emission

Conditions Vin : 100 VAC
Io : 100 %

HORIZONTAL

VERTICAL

5V

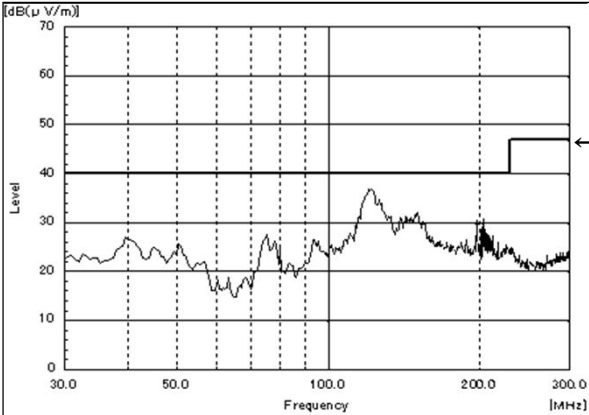
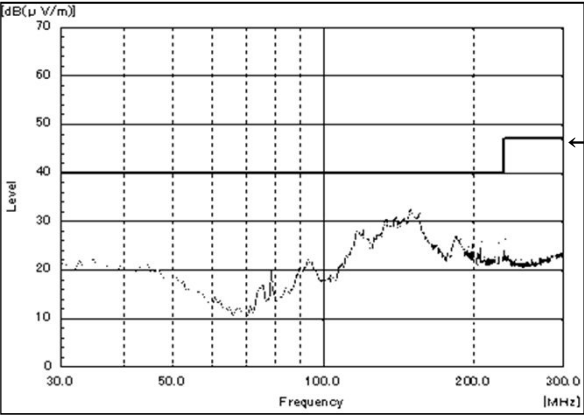

12V

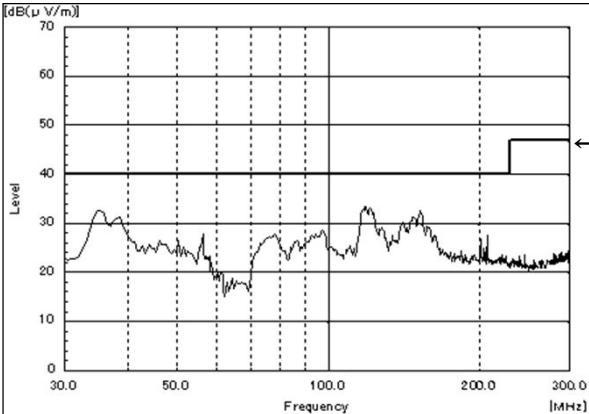
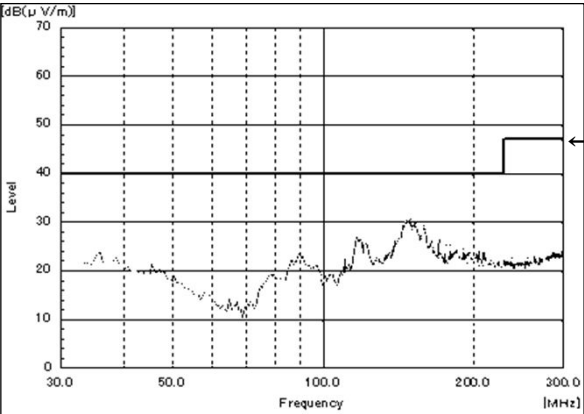

24V

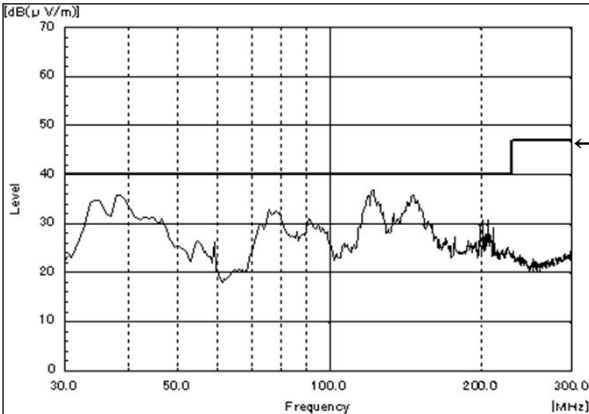
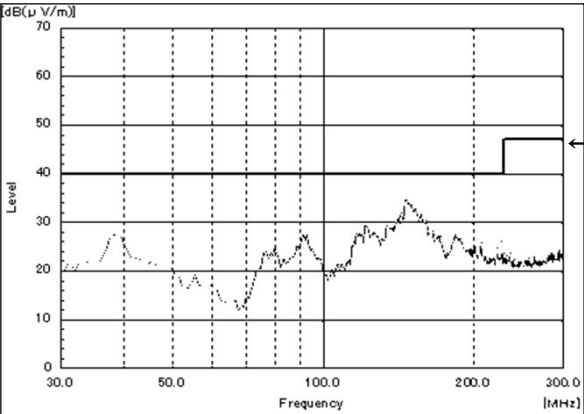

EN55011-B,EN55032-Bの限界値はVCCI class Bの限界値と同じ
Limit of EN55011-B,EN55032-B are same as its VCCI class B.

表示はピーク値です。
Indication is peak values.