

HFE2500

IEC 61000 TEST DATA

DWG: IA689-58-01		
APPD	CHK	DWG
Dorow P. Dec-18-11	<i>Pi P</i> 9-Nov-2011	<i>MICHAEL G.</i> 27.10.2011

INDEX**PAGE**

1. Electrostatic Discharge Immunity Test (IEC61000-4-2)	R-1
2. Radiated Radio-Frequency Electromagnetic Field Immunity Test (IEC61000-4-3)	R-2
3. Electrical Fast Transient / Burst Immunity Test (IEC61000-4-4)	R-3
4. Surge Immunity Test (IEC61000-4-5)	R-4
5. Conducted Disturbances Induced by Radio-Frequency Field Immunity Test (IEC61000-4-6)	R-5
6. Power Frequency Magnetic Field Immunity Test (IEC61000-4-8)	R-6
7. Voltage Dips, Short Interruptions Immunity Test (IEC61000-4-11)	R-7
8. Input Current Harmonics Test (IEC61000-3-2)	R-8

Test results are typical data. Nevertheless the following results are considered to be actual capability data because all units have nearly the same characteristics.

1. Electrostatic Discharge Immunity Test (IEC61000-4-2)

(1) Equipment used

NOISEKEN ESS-2000

Discharge resistance: 330 Ohm Capacity: 150pF

(2) Test conditions

Input voltage: Rated

Output voltage: Rated

Output current: 100%

Polarity: -, +

Number of tests: 10 times

Discharge interval: >1 Second

(3) Test method and Device test point

Contact discharge: FG, Case screw

Air discharge: Input and Output terminal

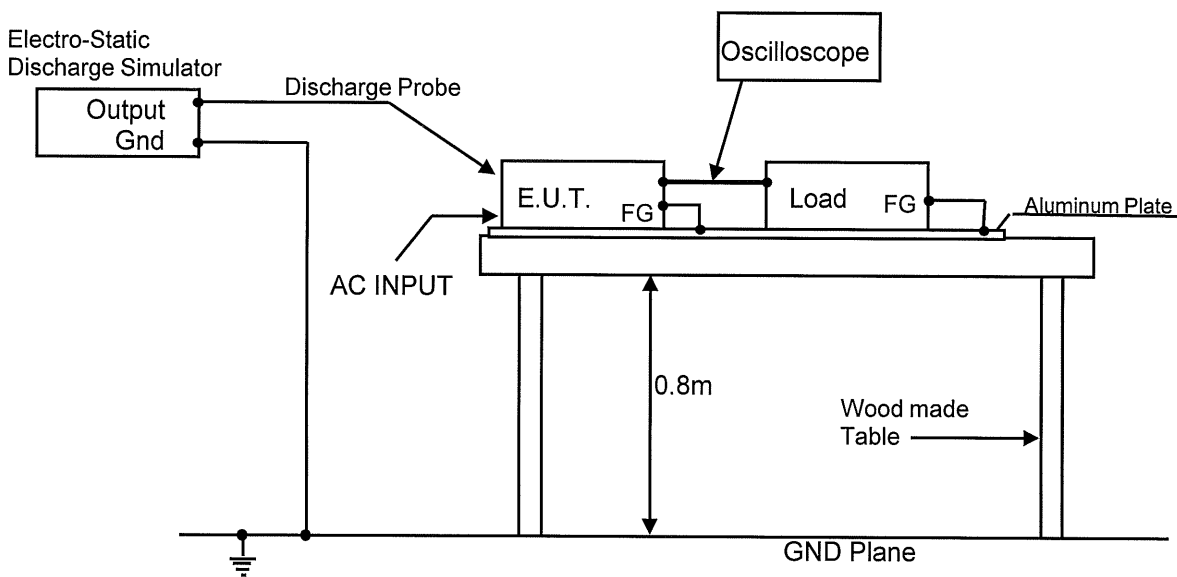

(4) Acceptable conditions

1. Output voltage regulation not to exceed $\pm 5\%$ of initial (before test) value during test.
2. Output voltage to be within regulation specification after the test.
3. Along with 1 and 2, no discharge of fire or smoke, as well as no output failure.

(5) Test Result

Contact Discharge (kV)	HFE2500	Air Discharge (kV)	HFE2500
4	PASS	8	PASS

HFE2500

2.Radiated Radio-Frequency Electromagnetic Field Immunity Test (IEC61000-4-3)

(1)Equipment used

Test Laboratory: Hermon Laboratories Ltd.

(2)Test conditions

Input voltage:	Rated	Output voltage:	Rated
Output current:	100%	Amplitude Modulated:	80%, 1kHz
Electromagnetic Frequency:	80~1000MHz	Ambient temperature:	25°C
Distance:	2.4m	Wave Angel:	Horizontal and Vertical
Sweep condition:	1.0% Step Up, 2.0 second Hold		
Test Angle:	Top/Bottom, Both Sides, Front/Back		

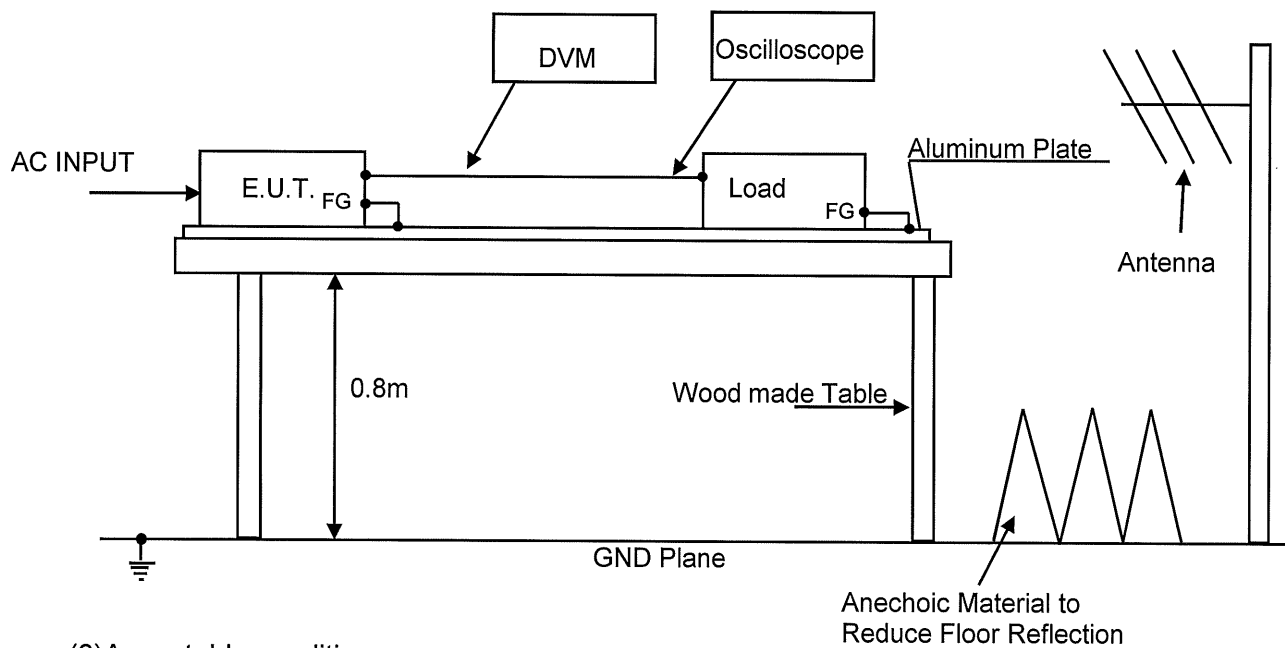

(3)Acceptable conditions

1. Output voltage regulation not to exceed $\pm 5\%$ of initial (before test) value during test.
2. Output voltage to be within regulation specification after the test.
3. Along with 1 and 2, no discharge of fire or smoke, as well as no output failure.

(4)Test Result

Radiated Field Strength (V/m)	HFE2500
3	PASS

3. Electrical Fast Transient / Burst Immunity Test (IEC61000-4-4)

(1) Equipment used

EFT/B Generator: SCHAFFNER NSG2025

(2) Test conditions

Input voltage:	Rated	Output voltage:	Rated
Output current:	100%	Test time:	1 minute
Polarity:	-, +	Ambient temperature:	25°C
Number of tests:	3 times		

(3) Test method and Device test point: Neutral (N), Line (L), Ground (FG)

Apply pulses from EFT/B Generator to N,L,FG separately, as well as, all at the same time.

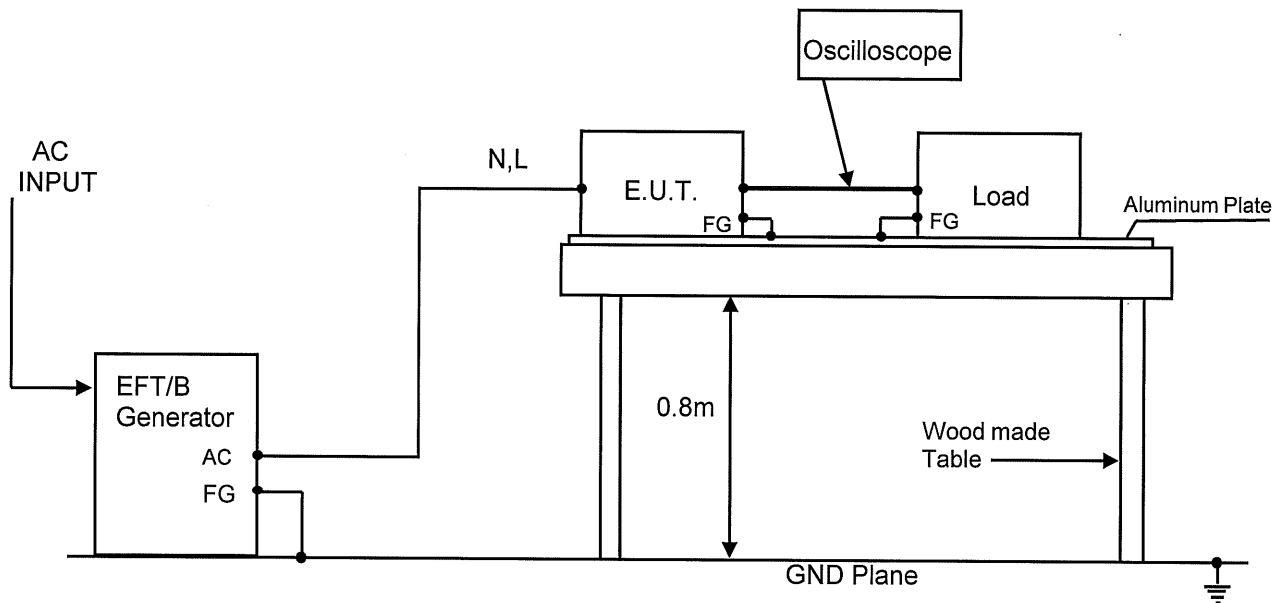

(4) Acceptable conditions

1. Output voltage regulation not to exceed $\pm 5\%$ of initial (before test) value during test.
2. Output voltage to be within regulation specification after the test.
3. Along with 1 and 2, no discharge of fire or smoke, as well as no output failure.

(5) Test Result

Test Voltage (kV)	Repetition Rate (kHz)	HFE2500
2	5	PASS

4. Surge Immunity Test (IEC61000-4-5)

(1) Equipment used

Surge Generator: SCHAFFNER-NSG651
 Coupling impedance: Common - 12 Ohm
 Normal - 2 Ohm
 Coupling capacitance: Common - 9 uF
 Normal - 18 uF
 Coupling network: SCHAFFNER-CDN110

(2) Test method and devise test point

Input voltage: Rated Output voltage: Rated
 Output current: 100% Number of tests: 5 times
 Polarity: -, + Mode: Common, Normal
 Phase: 0,90 DEG. Ambient temperature: 25°C

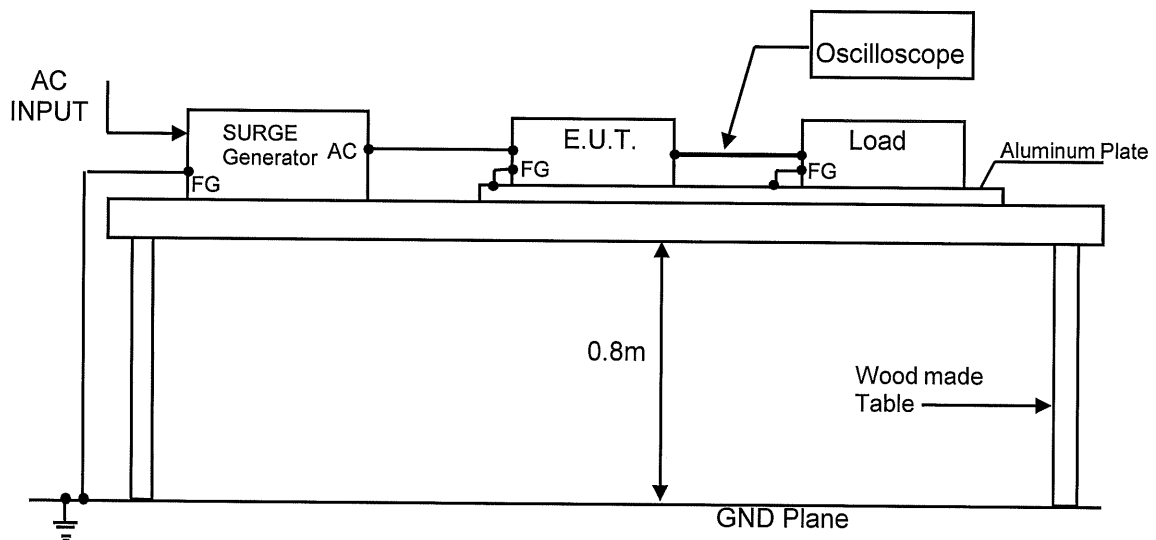

(3) Acceptable conditions

1. Output voltage regulation not to exceed $\pm 5\%$ of initial (before test) value during test.
2. Output voltage to be within regulation specification after the test.
3. Along with 1 and 2, no discharge of fire or smoke, as well as no output failure.

(4) Test Result

Test Voltage (kV) Common	HFE2500	Test Voltage (kV) Normal	HFE2500
2.0	PASS	2.0	PASS
4.0	PASS		

5. Conducted Disturbances Induced by Radio-Frequency Field Immunity Test (IEC61000-4-6)

(1) Equipment used

RF Signal Generator 10kHz-1050MHz:	Fluke, 6061A
RF Amplifier 10kHz-220MHz, 150W:	Amplifier Research, 150L
Coupling/Decoupling Network:	HL CDN 801-M3

(2) Test Condition:

Input voltage:	Rated	Output voltage:	Rated
Output current:	100%	Electromagnetic	
		Frequency:	150kHz~80MHz

Sweep Condition: 1.0% Step Up, 2.0 Seconds Hold

Ambient temperature: 25°C

(3) Test Method:

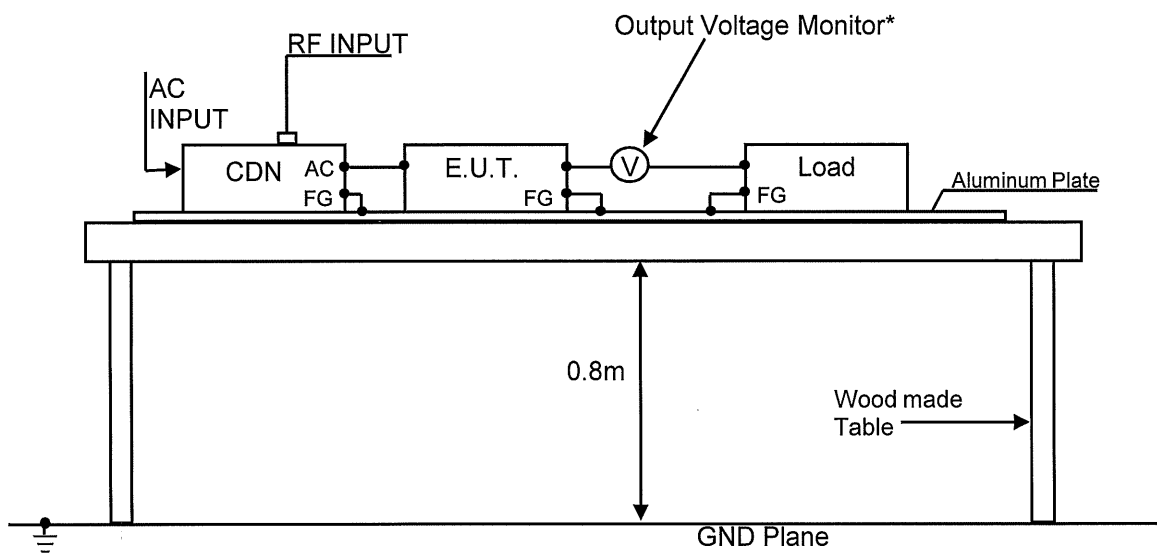

*Used Analog Voltage Meter

(4) Acceptable conditions

1. Output voltage regulation not to exceed $\pm 5\%$ of initial (before test) value during test.
2. Output voltage to be within regulation specification after the test.
3. Along with 1 and 2, no discharge of fire or smoke, as well as no output failure.

(5) Test Result

Voltage Level (V)	HFE2500
3	PASS

6.Power Frequency Magnetic Field Immunity Test (IEC61000-4-8)

(1)Equipment used

AC High Current Generator for
Magnetic Field immunity tests:

HL, MFG-130A

(2)Test Condition:

Input voltage:	Rated	Output voltage:	Rated
Output current:	100%	Frequency:	50Hz
Magnetic Field Strength:	30A/m	Ambient temperature:	25°C
Duration Time:	10min.		

(3)Test Method:

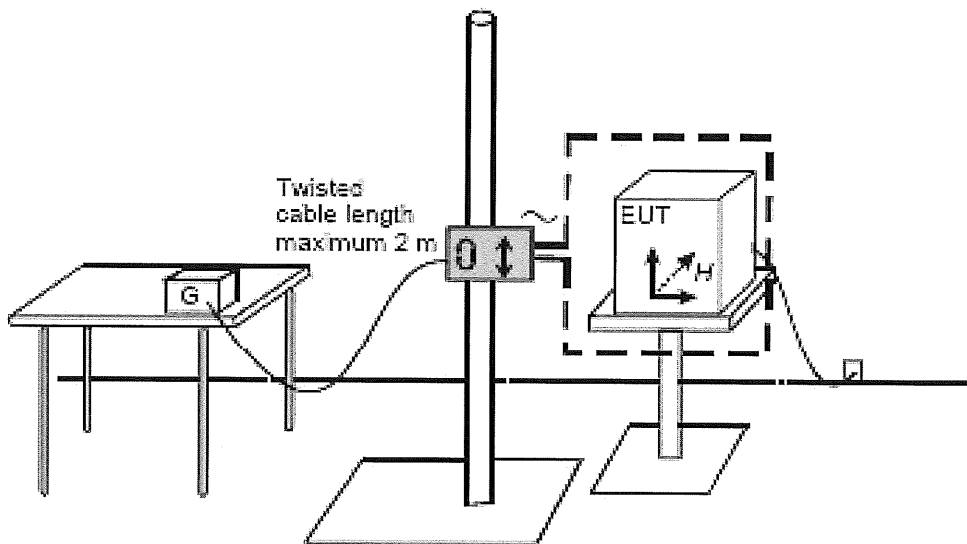

(4)Acceptable conditions

1. Output voltage regulation not to exceed $\pm 5\%$ of initial (before test) value during test.
2. Output voltage to be within regulation specification after the test.
3. Along with 1 and 2, no discharge of fire or smoke, as well as no output failure.

(5)Test Result

EUT positions	Result
X	PASS
Y	PASS
Z	PASS

7.Voltage Dips,Short Interruptions Immunity Test (IEC61000-4-11)

(1)Equipment used
 Voltage Dips Generator: CI, 5001ix
 Oscilloscope: Yokogawa, DL1740EL

(2)Test Condition:
 Input voltage: Rated Output voltage: Rated
 Output current: 100% Frequency: 50Hz
 Repetition: 0.1Hz Ambient temperature:25°C
 Number of pulse: 3

(3)Test Method:

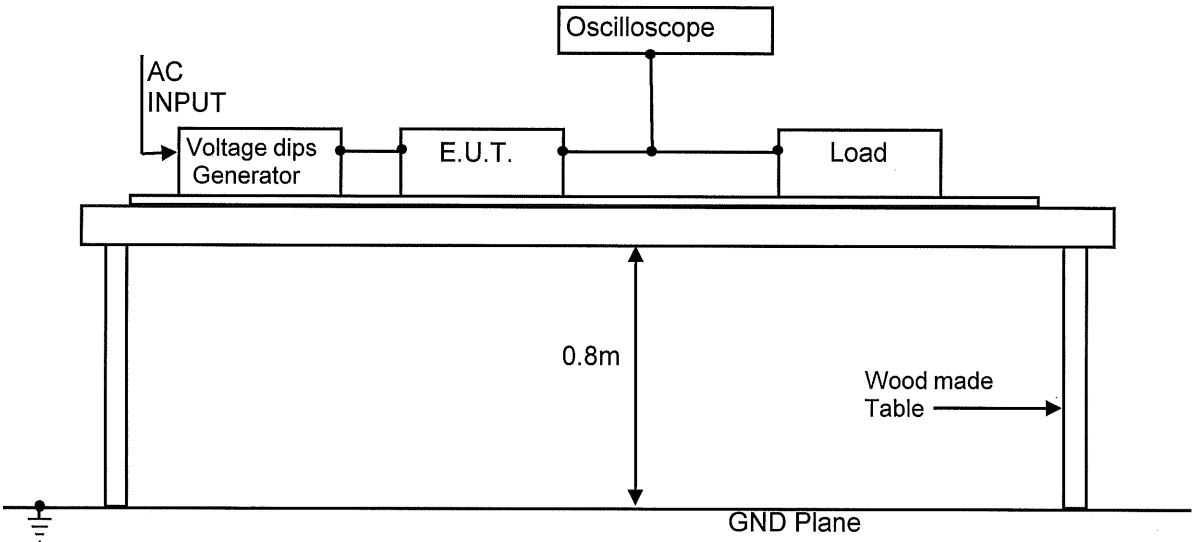

- (4)Acceptable conditions
- 1.Output voltage to be within output voltage regulation specification after the test
 - 2.No discharge of fire or smoke

(5)Test Result

Dip rate	Continue time	Result
30% voltage dip	500ms	PASS
60% voltage dip	200ms	PASS
>95% voltage dip	20ms; 5,000ms	PASS

8. Input Current Harmonics Test (IEC61000-3-2)

Model:

(1) Equipment used

AC Power Analyzer:
PACS-1 (California Instruments)

AC Source:
5001 IX (California Instruments)

(2) Test conditions:

Input voltage: 115VAC; 230VAC

Output current: 100%

(3) Test Method:

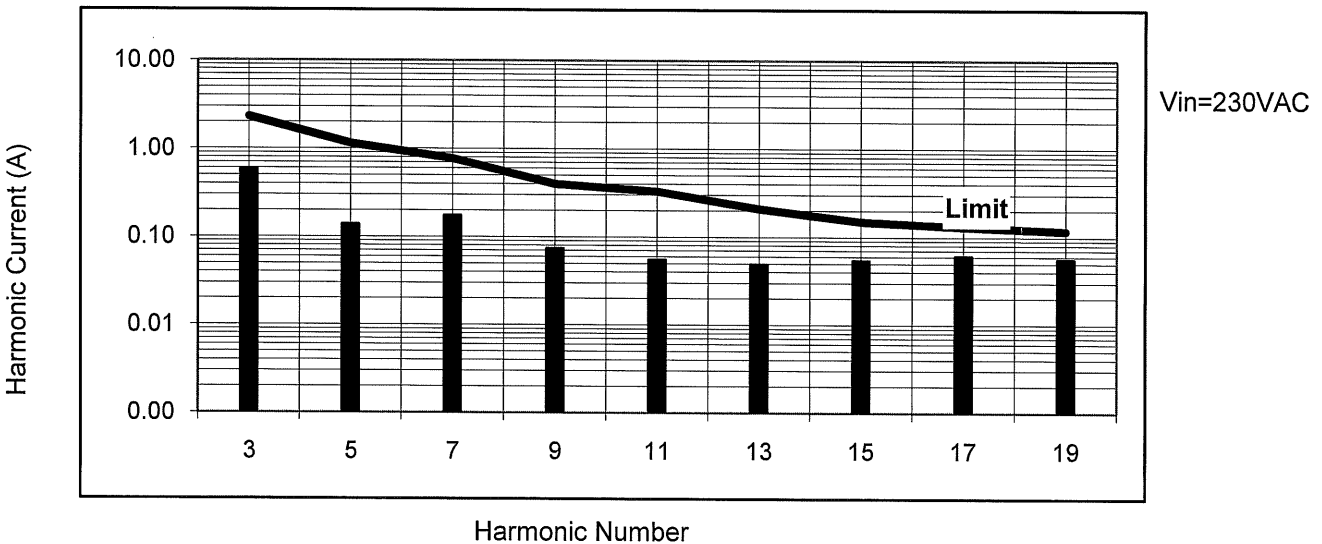
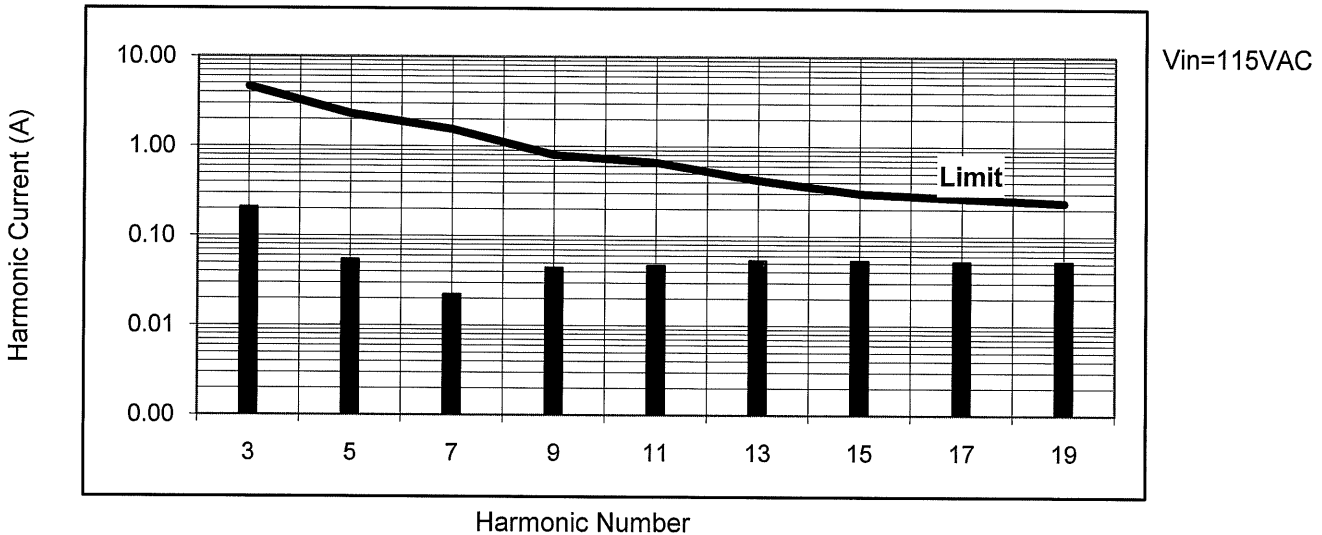
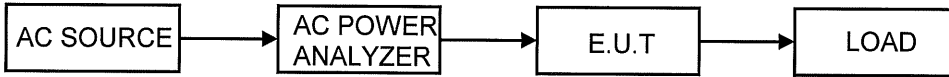

Vin	HARMONICS									
	3	5	7	9	11	13	15	17	19	
115	4.6	2.28	1.54	0.8	0.66	0.42	0.3	0.264	0.236	
VAC	0.21	0.05	0.02	0.04	0.05	0.05	0.05	0.05	0.05	
230	2.3	1.14	0.77	0.4	0.33	0.21	0.15	0.132	0.118	
VAC	0.58	0.14	0.17	0.07	0.06	0.05	0.05	0.06	0.06	

Input Current Harmonics EN61000-3-2 Limit

Input Current Harmonics-Measurement