

LS25

TEST DATA

IEC61000 SERIES

DWG. No PA580-58-01A		
APPD	CHK	DWG
<i>Zeff</i> 20/1/16	<i>Ramach</i> 20-Jan-16	<i>J. C. Liu</i>

INDEX

	PAGE
1. Electrostatic Discharge Immunity Test (IEC61000-4-2)	R-1
2. Radiated Radio-Frequency Electromagnetic Field Immunity Test (IEC61000-4-3).....	R-3
3. Electrical Fast Transient / Burst Immunity Test (IEC61000-4-4)	R-5
4. Surge Immunity Test (IEC61000-4-5)	R-6
5. Conducted Disturbances Induced by Radio-Frequency Field Immunity Test (IEC61000-4-6)	R-7
6. Power Frequency Magnetic Field Immunity Test (IEC61000-4-8)	R-8
7. Voltage Dips, Short Interruptions Immunity Test (IEC61000-4-11)	R-9

※ Test results are typical data. Nevertheless the following results are considered to be actual capability data because all units have nearly the same characteristics.

1. Electrostatic Discharge Immunity Test (IEC61000-4-2)

MODEL : LS25

(1) Equipment Used

Electrostatic Discharge Simulator : NSG435 (SCHAFFNER)
 Discharge Resistance : 330Ω Capacitor : 150pF

(2) Test Conditions

Input Voltage : 230VAC Output Voltage : Rated
 Output Current : 100% Polarity : +, -
 Number of Tests : 10 times Ambient Temperature : 25°C
 Discharge Interval : >1 Second

(3) Test Method and Device Test Point

Contact Discharge : FG, Case Screw
 Air Discharge : Input and Output Terminal, FG, Case Screw

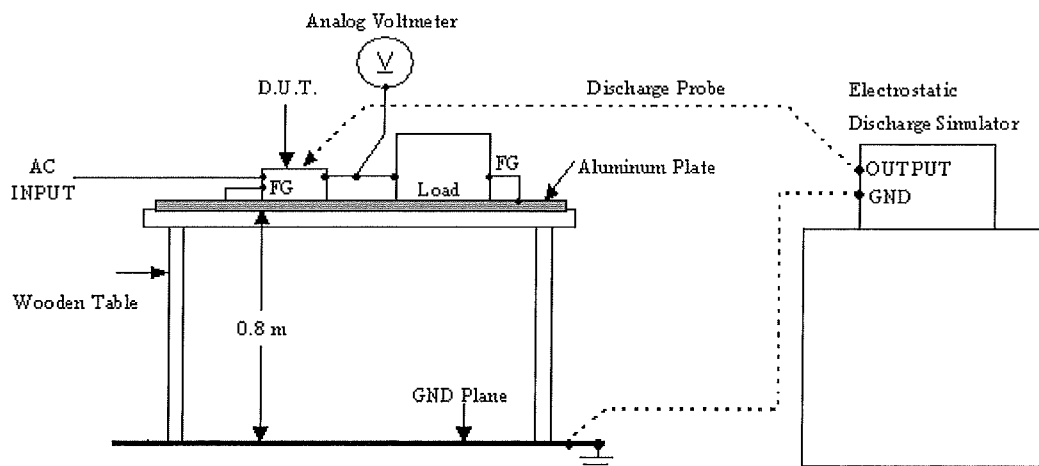

(4) Acceptable Conditions

1. Output voltage regulation not to exceed $\pm 5\%$ of initial (before test) value during test.
2. Output voltage to be within regulation specification after the test.
3. Along with 1 and 2, no discharge of fire or smoke, as well as no output failure.

(5) Test Results

Contact Discharge (kV)	LS25-5	Air Discharge (kV)	LS25-5
2	PASS	2	PASS
4	PASS	4	PASS
-	-	8	PASS

2. Radiated Radio-Frequency Electromagnetic Field Immunity Test (IEC61000-4-3)

MODEL : LS25

(1) Equipment Used

Dual Channel EPM Power Meter	:	E4419B
Function / Arbitrary Waveform Generator	:	33220A
Synthesized Signal Generator	:	8648C
Power Amplifier (0.8GHz – 3GHz)	:	CBA9429
Power Amplifier (80 MHz – 1GHz)	:	CBA9433
Average Power Sensor	:	E9034A
Log-Periodic Dipole Antenna	:	LPDA-0803
Broad-Band Horn Antenna	:	E322

(2) Test Conditions

Input Voltage	:	230VAC	Output Voltage	:	Rated
Output Current	:	100%	Amplitude Modulated	:	80%, 1kHz
Electromagnetic Frequency	:	80~1000MHz	Ambient Temperature	:	25°C
Distance	:	3.0m	Wave Angle	:	Horizontal and Vertical
Sweep Conditions	:	1.0% Step Up, 2.8 Seconds Hold			
Test Angle	:	Top/Bottom, Both Sides, Front/Back			

(3) Test Method

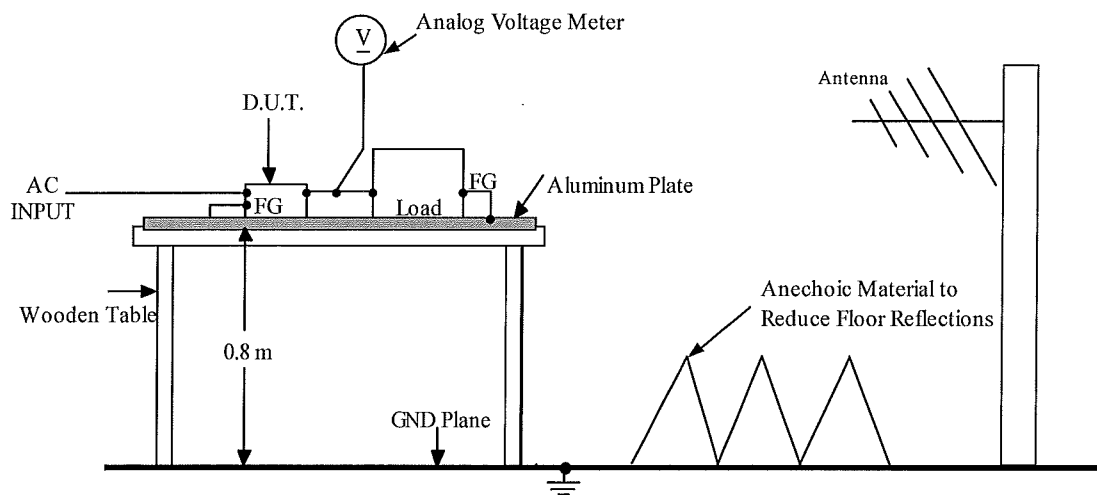

(4) Acceptable Conditions

1. Output voltage regulation not to exceed $\pm 5\%$ of initial (before test) value during test.
2. Output voltage to be within regulation specification after the test.
3. Along with 1 and 2, no discharge of fire or smoke, as well as no output failure.

(5) Test Results

Radiation Field Strength (V/m)	LS25-5
1	PASS
3	PASS
10	PASS

3. Electrical Fast Transient / Burst Immunity Test (IEC61000-4-4)

MODEL : LS25

(1) Equipment Used

EFT/B (Generator) : MODULA 6150 (SCHAFFNER)

(2) Test Conditions

Input Voltage	: 230VAC	Output Voltage	: Rated
Output Current	: 100%	Polarity	: +, -
Number of Tests	: 3 times	Ambient Temperature	: 25°C
Test time	: 1 minute		

(3) Test Method and Device Test Points

Apply to (N,L,FG), (NL), (N), (L), (FG)

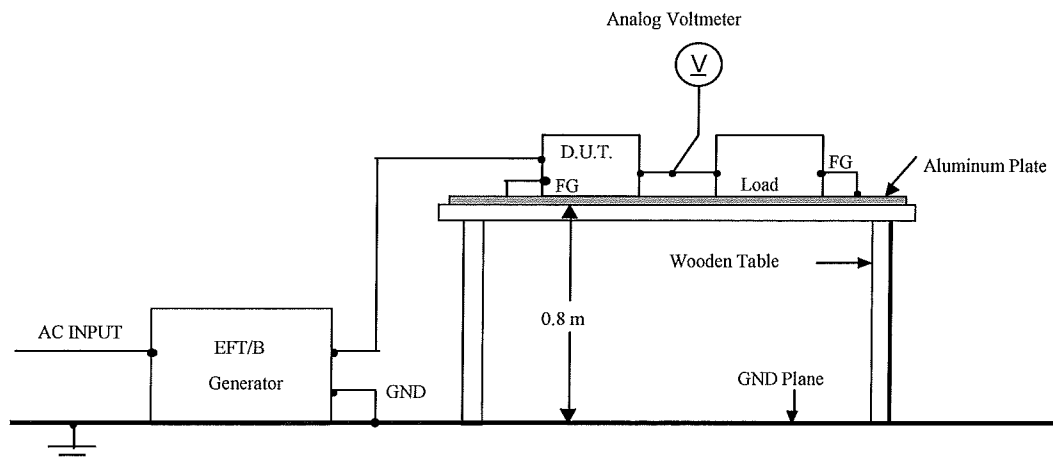

(4) Acceptable Conditions

1. Output voltage regulation not to exceed $\pm 5\%$ of initial (before test) value during test.
2. Output voltage to be within regulation specification after the test.
3. Along with 1 and 2, no discharge of fire or smoke, as well as no output failure.

(5) Test Results

Test Voltage (kV)	Repetition Rate (kHz)	LS25-5
0.5	5.0	PASS
1.0	5.0	PASS
2.0	5.0	PASS

4. Surge Immunity Test (IEC61000-4-5)

MODEL : LS25

(1) Equipment Used

Impulse Network : SRG 6501
 Pulse Coupling Network CDN 6501
 Coupling Impedance : Common 12Ω Normal 2Ω
 Coupling Capacitance : Common 9μF Normal 18μF

(2) Test Conditions

Input Voltage : 230VAC Output Voltage : Rated
 Output Current : 100% Number of Tests : 3 times
 Polarity : +, - Mode : Common, Normal
 Phase : 0, 90 deg Ambient Temperature : 25°C

(3) Test Method and Device Test Points

Apply to Common mode (N-FG, L-FG) and Normal mode (N-L).

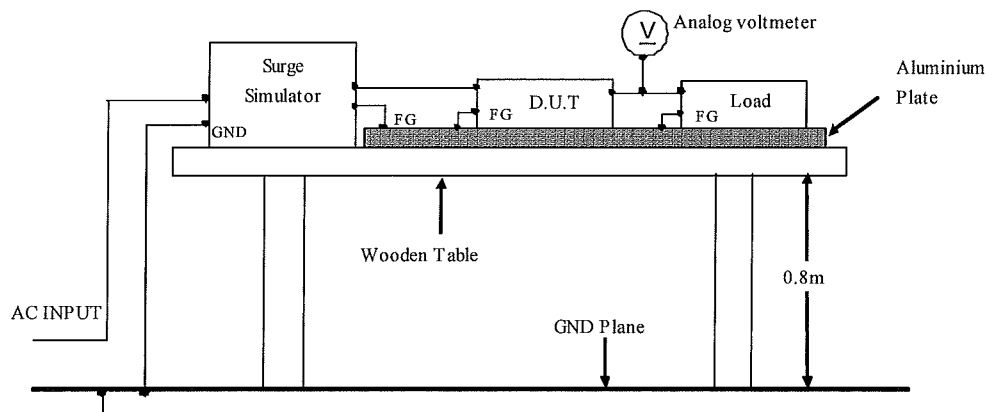

(4) Acceptable Conditions

1. Output voltage regulation not to exceed ±5% of initial (before test) value during test.
2. Output voltage to be within regulation specification after the test.
3. Along with 1 and 2, no discharge of fire or smoke, as well as no output failure.

(5) Test Results

Test Voltage (kV) Common	LS25-5	Test Voltage (kV) Normal	LS25-5
0.5	PASS	0.5	PASS
1.0	PASS	1.0	PASS
2.0	PASS	-	-

5. Conducted Disturbances Induced by Radio-Frequency Field Immunity Test (IEC61000-4-6)

MODEL : LS25

(1) Equipment Used

Schaffner HF Generator : NSG2070-1
 FCC Power Line Coupling Decoupling Network : FCC-801-M3-16A

(2) Test Conditions

Input Voltage : 230VAC/50Hz Output Voltage : Rated
 Output Current : 100% Electromagnetic Frequency : 150kHz~80MHz
 Ambient Temperature : 25°C
 Sweep Conditions : 1.0% Step Up, 2.8 Seconds Hold

(3) Test Method

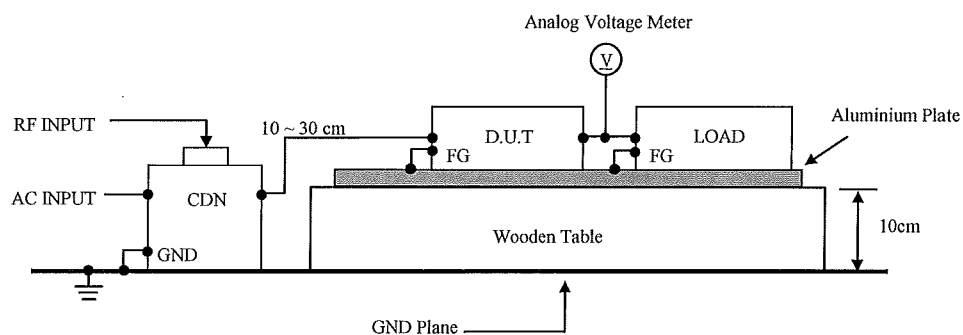

(4) Acceptable Conditions

1. Output voltage regulation not to exceed $\pm 5\%$ of initial (before test) value during test.
2. Output voltage to be within regulation specification after the test.
3. Along with 1 and 2, no discharge of fire or smoke, as well as no output failure.

(5) Test Results

Test Voltage (V)	LS25-5
1	PASS
3	PASS
10	PASS

6. Power Frequency Magnetic Field Immunity Test (IEC61000-4-8)

MODEL : LS25

(1) Equipment Used

Schaffner Immunity Tester – BEST1 : BEST EMC
 Schaffner Magnetic Field Generator : INA 702

(2) Test Conditions

Input Voltage	: 230VAC	Output Voltage	: Rated
Output Current	: 100%	Magnetic Frequency	: 50 Hz
Test Time	: > 10 sec (Each direction)	Ambient Temperature	: 25°C
Direction	: X, Y, Z		

(3) Test Method and Device Test Point

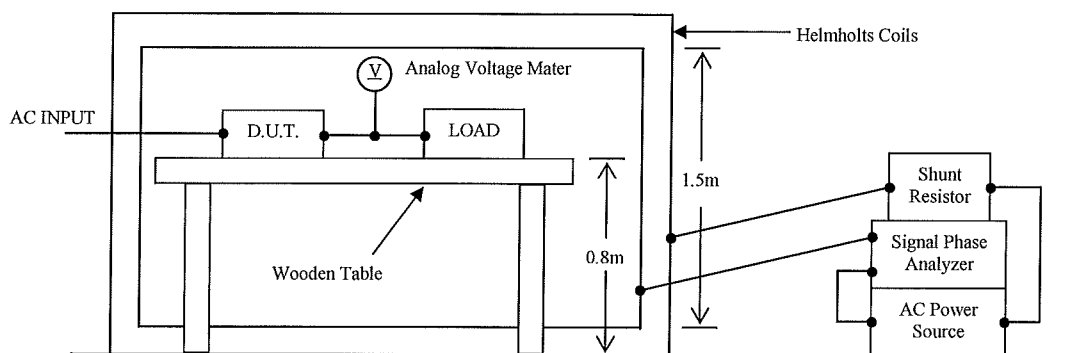

(4) Acceptable Conditions

1. Output voltage regulation not to exceed $\pm 5\%$ of initial (before test) value during test.
2. Output voltage to be within output voltage regulation specification after the test.
3. Along with 1 and 2, no discharge of fire or smoke, as well as no output failure.

(5) Test Result

Magnetic Field Strength (A/m)	LS25-5
1	PASS
3	PASS
10	PASS
30	PASS

7. Voltage Dips, Short Interruptions Immunity Test (IEC61000-4-11)

MODEL : LS25

(1) Equipment Used

Test Generator : Programmable AC Source Model 61505 (CHROMA)

(2) Test Conditions

Input Voltage	: 230VAC	Output Voltage	: Rated
Output Current	: 100%	Ambient Temperature	: 25°C
Number of Tests	: 3 times	Test Interval	: > 10 sec.

(3) Test Method and Device Test Point

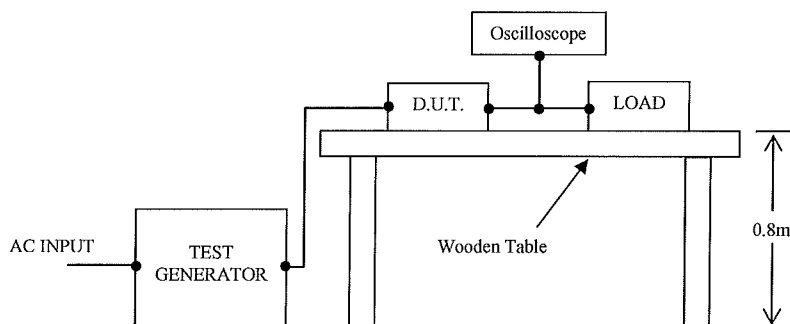

(4) Acceptable Conditions

At Test level 70%

1. Output voltage regulation not to exceed $\pm 5\%$ of initial (before test) value during test.
2. Output voltage to be within output voltage regulation specification after the test.
3. Along with 1 and 2, no discharge of fire or smoke, as well as no output failure.

At Test level 40%, 0%

1. Output voltage to be within output voltage regulation specification after the test.
2. No discharge of fire or smoke.

(5) Test Result

Test Level	Dip Rate	Continue Time	LS25-5
70%	30%	10ms	PASS
40%	60%	100ms	PASS
0%	100%	5000ms	PASS