

# *HWS300P-600P Series*

## *Instruction Manual*

### **BEFORE USING THE POWER SUPPLY UNIT**

Be sure to read this instruction manual thoroughly before using this product. Pay attention to all cautions and warnings before using this product. Incorrect usage could lead to an electrical shock, damage to the unit or a fire hazard.

### **DANGER**

Never use this product in locations where flammable gas or ignitable substances are present.

### **INSTALLATION WARNING**

- When installing, ensure that work is done in accordance with the instruction manual. When installation is improper, there is risk of electric shock and fire.
- Installation shall be done by Service personnel with necessary and appropriate technical training and experience. There is a risk of electric shock and fire.
- Do not cover the product with cloth or paper etc. Do not place anything flammable around. This might cause damage, electric shock or fire.

### **WARNING on USE**

- Do not touch this product or its internal components while circuit in operation, or shortly after shutdown. You may receive a burn.
- While this product is operating, keep your hands and face away from it as you may be injured by an unexpected situation.
- There are cases where high voltage charge remains inside the product. Therefore, do not touch even if they are not in operation as you might get injured due to high voltage and high temperature. You might also get electric shock or burn.
- Do not make unauthorized changes to this product nor remove the cover as you might get an electric shock or might damage the product. We will not be held responsible after the product has been modified, changed or dis-assembled.
- Do not use this product under unusual condition such as emission of smoke or abnormal smell and sound etc. Please stop using it immediately and shut off the product.

It might lead to fire and electric shock. In such cases, please contact us. Do not attempt repair by yourself, as it is dangerous for the user.

- Do not operate and store these products in environments where condensation occurs due to moisture and humidity. It might lead fire and electric shock.
- Do not drop or apply shock to this product. It might cause failure. Do not operate these products mechanical stress is applied.

### **CAUTION on MOUNTING**

- Confirm connections to input/output terminals are correct as indicated in the instruction manual before switching on.
- Input voltage, Output current, Output power, ambient temperature and ambient humidity should be kept within specifications, otherwise the product will be damaged.
- Input line, please use the wires as short and thick as possible.
- Do not use this product in special environment with strong electromagnetic field, corrosive gas or conductive substances and direct sunlight, or places where product is exposed to water or rain.
- Mount this product properly in accordance with the instruction manual, mounting direction and shall be properly be ventilated.
- Please shut down the input when connecting input and output of the product.
- When installing in environment where conductive foreign, dust and liquid may be present, please consider penetration of above foreign material in the power supply by installing filter, to prevent trouble or malfunction.

### **CAUTION on USE**

- Product individual notes are shown in the instruction manual. If there is any difference with common notes individual notes shall have priority.
- Before using this product, be sure to read the catalog and instruction manual. There is risk of electric shock or damage to the product or fire due to improper use.
- Input voltage, Output current, Output power, ambient temperature and ambient humidity should be kept within specifications, otherwise the product will be damaged, or cause electric shock or fire.
- If the built-in fuse is blown, do not use the product even after replacing the fuse, as there is risk of abnormality inside. Be sure to request repair to our company.

- For products without built-in protection circuit (element, fuse, etc.), insert fuse at the input to prevent smoke, fire during abnormal operation.  
As for products with built-in protection circuit, depending on usage conditions, built-in protection circuit might not work. It is recommended to provide separate proper protection circuit.
- For externally mounted fuse do not use other fuses aside from our specified and recommended fuse.
- This product was made for general purpose electronic equipment use and is not designed for applications requiring high safety (such as extremely high reliability and safety requirements. Even though high reliability and safety are not required, this product should not be used directly for applications that have serious risk for life and physical safety. Take sufficient consideration in fail-safe design (such as providing protective circuit or protective device inside the system, providing redundant circuit to ensure no instability when single device failure occurs).
- When used in environments with strong electromagnetic field, there is possibility of product damage due to malfunction.
- When used in environment with corrosive gas (hydrogen sulfide, sulfur dioxide, etc.), there is possibility that they might penetrate the product and lead to failure.
- When used in environments where there is conductive foreign matter or dust, there is possibility of product failure or malfunction.
- Provide countermeasure for prevention of lightning surge voltage as there is risk of damage due to abnormal voltage.
- Connect together the frame ground terminal of the product and the ground terminal of the equipment for safety and noise reduction. If these ground is not connected together, there is risk of electric shock.
- Parts with lifetime specifications (built-in fan electrolytic capacitor) are required to be replaced periodically. Set the overhaul period depending on the environment of usage and perform maintenance. Also, note that there are cases when EOL products cannot be overhauled.
- Take care not to apply external abnormal voltage to the output. Especially, applying reverse voltage or overvoltage more than the rated voltage to the output might cause failure, electric shock or fire.
- This power supply is designed for use within an end product.
- This product has a built-in fan for air-cooling. Do not block the air intake and exhaust as this might lead to fire.
- The output of this product is considered to be a hazardous energy level (The voltage is 2V or more and the power is 240VA or more). It must not be made accessible to users. Protection must be provided for Service Engineers against indirect contact with the output terminals and/or to prevent tools being dropped across them. While working on this product, the AC input power must be switched off and the input and output voltage should be zero.

#### **Note**

- Take note that traces of sheet metal processing be left in our power supplies.
- When disposing product, follow disposal laws of each municipality.
- Published EMI (CE, RE) or immunity is the result when measured in our standard measurement conditions and might not satisfy specification when mounted and wired inside end-user equipment. Use the product after sufficiently evaluating at actual end-user equipment.
- When exporting our products, apply for necessary permissions as required by rules and regulations of Foreign Exchange and Foreign Trade Control Act.
- Catalogue, contents of the instruction manual may be changed without a prior notice. Refer to latest catalogue or instruction manual.
- Reproduction or reprinting the instruction manual or its portion is forbidden without our permission.

#### **LONG-TERM STORAGE METHOD AND LONG-TERM STORAGE PERIOD**

- Please keep the product in carton box.
- Please do not apply excessive vibration, shock or mechanical stress applied directly to the product.
- Please keep away from direct sunlight.
- For long-term storage temperature and humidity, the following conditions shall be used as a guideline :  
Temperature range : 5°C~30°C  
Humidity range : 40%~60%RH  
Please keep away from the places where temperature and humidity can change drastically.  
It can cause condensation on the product or deterioration.

- For long-term storage period, we recommend to use within 2 years after receiving the product.  
There is tendency that the leakage current of an aluminium electrolytic capacitor may increase when stored without using for a long time. This phenomenon can be improved by applying voltage to the aluminum electrolytic capacitor to reduce the increased leakage current through the self-recovery effect of the electrolyte. For reference, before using products that have been stored for a very long time, please warm-up first for 30 minutes or more without taking load.  
< Criterion of warm up voltage condition >  
(1)Implementation period : 1 year or above after the delivery  
(2)Electrical continuity condition  
Input voltage : Rating  
Load : 0A  
Ambient temperature : Normal temperature  
Time : 30 minutes or more

## 1. Model name identification method

**HWS 300P – 24**

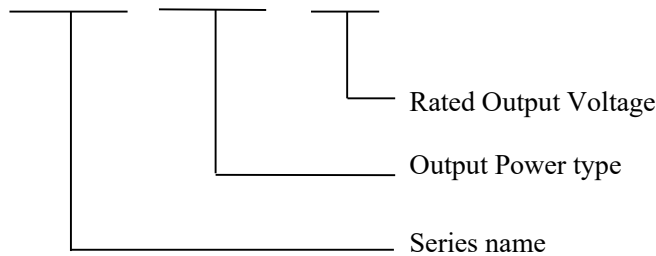

## 2. Terminal Explanation

Please pay extra attention to the wiring. Incorrect connection will damage the power supply.

### 2-1. Front Panel Explanation

#### HWS300P

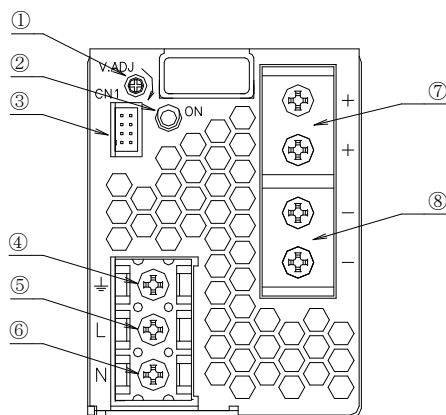

#### HWS600P

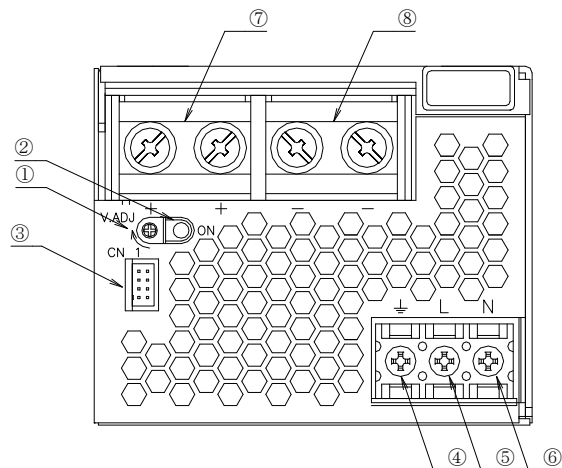

- ① V.ADJ : Output voltage adjustment trimmer.  
(The output voltage rises when a trimmer is turned clockwise.)
- ② ON : Output (Power On) indication LED.  
(The indicator turns on when the power supply output is in normal operating condition.)
- ③ CN1 : Remote ON/OFF control signal, Current balance signal (only as for HWS600P), Power fail signal.  
(Refer to 2-2.)
- ④  $\perp$  : Protective Earth terminal (Frame ground), M4 screw.
- ⑤ AC input terminal L : Live Line (Fuse in line), M4 screw.
- ⑥ AC input terminal N : Neutral line, M4 screw.
- ⑦ + : + Output terminal  
(HWS300P: M4 screw x 2 / HWS600P: M5 screw x 2)
- ⑧ - : - Output terminal  
(HWS300P: M4 screw x 2 / HWS600P: M5 screw x 2)

## 2-2. CN1 Connector pin Configuration and Function

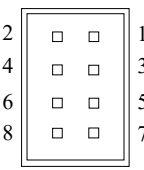
	Pin No.	Configuration	Function
	1	COM	GND for PC signals (Only as for HWS600P. HWS300P is NC.)
	2	PC	Current balance terminal. ( For output current balancing in parallel operation. Only as for HWS600P. HWS300P is NC.)
	3	NC	No connect
	4	NC	No connect
	5	CNT	Remote ON/OFF control terminal. ( Power supply ON/OFF control with an external signal. )
	6	TOG	GND for CNT and PF signals. ( Same as Pin No.8 )
	7	PF	Power fail signal (PF signal) output terminal. (Uses the open collector method. As the output voltage drops, or Fan stops, "Power Fail" terminal will output "High".)
	8	TOG	GND for CNT and PF signals. ( Same as Pin No.6 )

### CN1 Connector & Housing & Terminal Pin

PART DESCRIPTION	PART NAME	MANUFACT
PIN HEADER	S8B-PHDSS	J.S.T.

SOCKET HOUSING	PHDR-08VS	J.S.T.
TERMINAL PINS	SPHD-002T-P0.5(AWG28~24) or SPHD-001T-P0.5(AWG26~22)	J.S.T.
HAND CRIMPING TOOL	YRS-620(SPHD-002T-P0.5) or YC-610R(SPHD-001T-P0.5)	J.S.T.

※Attached connector is mounted on CN1 at shipment. (CNT-TOG is short)

### 3. Block Diagram

HWS300P, HWS600P

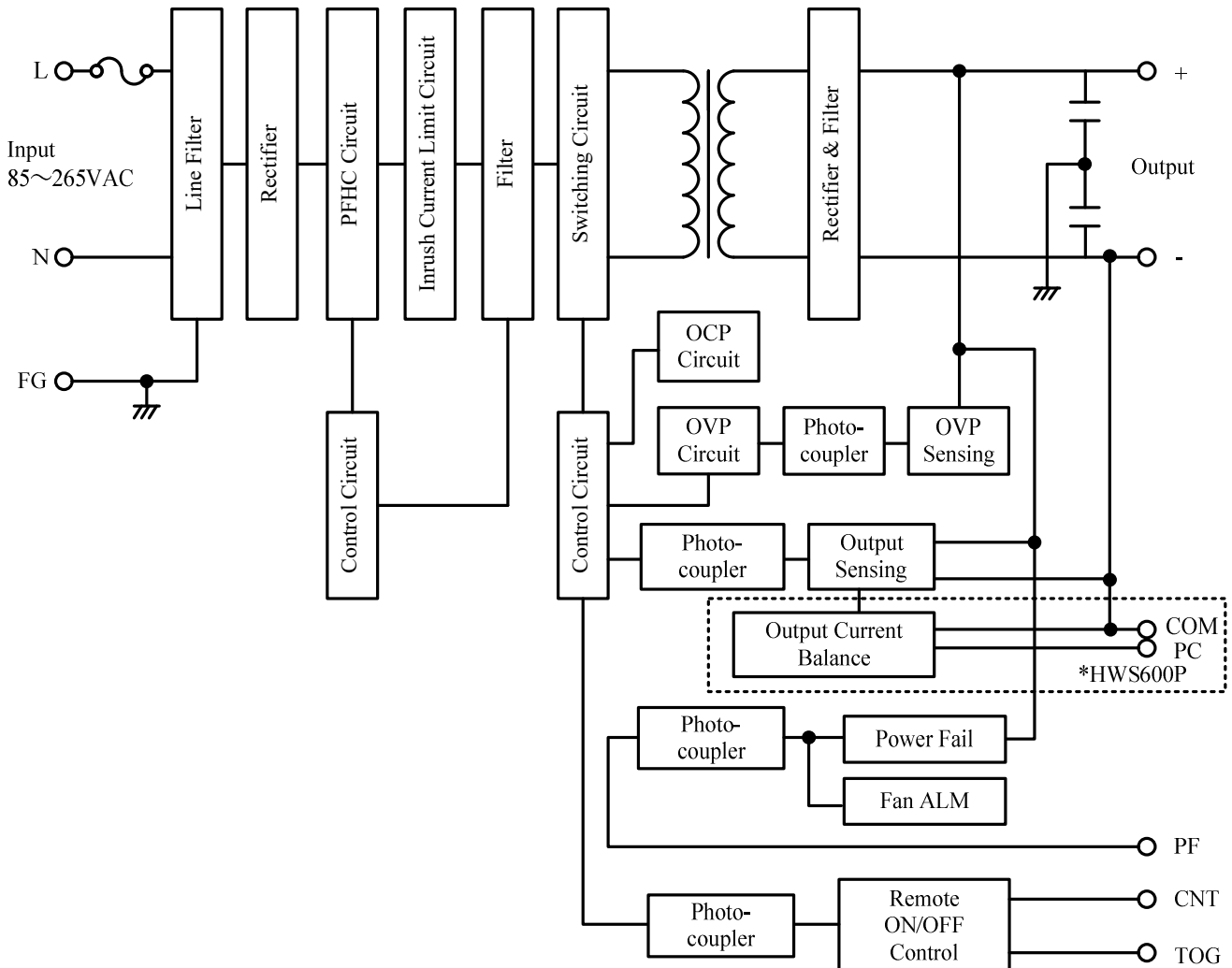

- Circuit topology, switching frequency  
 Cascade forward topology 190kHz (fixed)  
 PFHC circuit : active filter  
 HWS300P: 80kHz (fixed), HWS600P: 90kHz (fixed)
- Fuse rating :  
 HWS300P: 12A, HWS600P: 20A

## 4. Sequence time chart

HWS300P,HWS600P

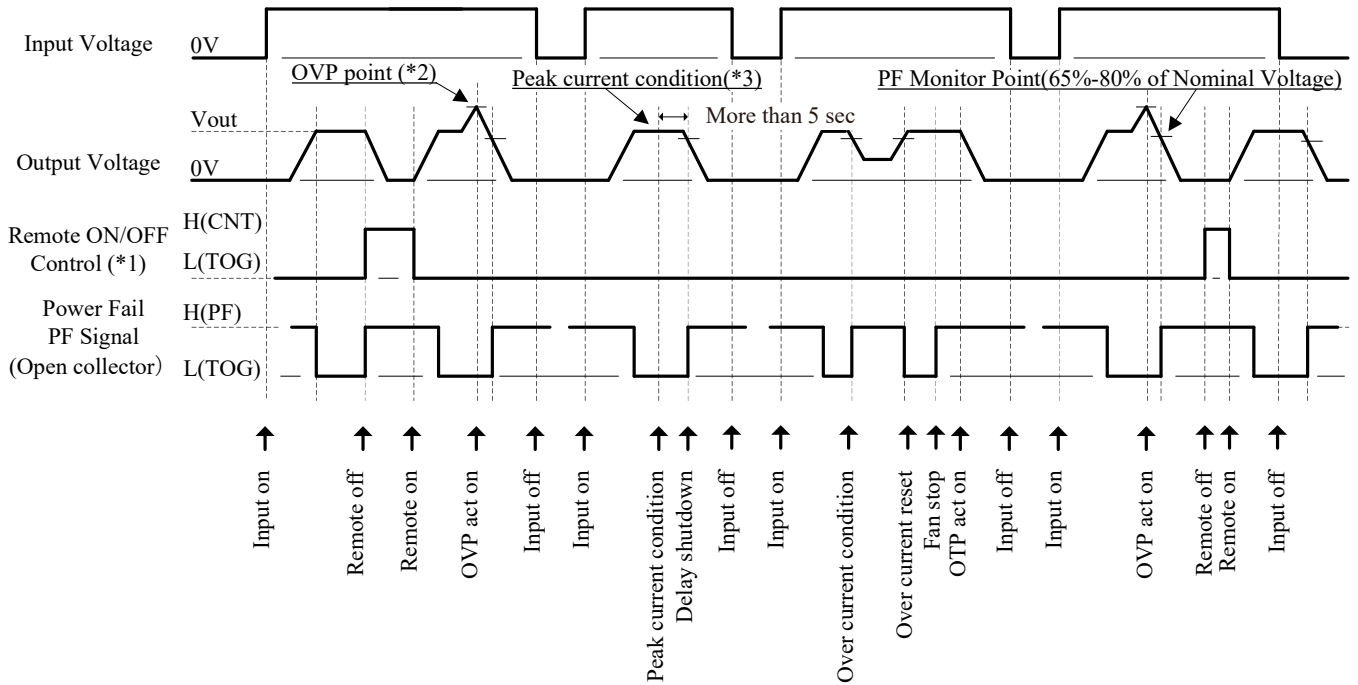

(\*1) Level

$2.4V \leq H \leq 12V$  or Open

$0V \leq L \leq 0.8V$  or Short

(\*2) OVP Point

115%-135%

(\*3) Peak current condition

When the Product operate peak Current for more than 5 sec,  
the delay shut down function operates and the output will shut down.

## 5. Terminal Connection Method

Please pay extra attention to the wiring. Incorrect connection will damage the power supply.

- When connecting input and output wiring, and CN1, input AC-Line should be off.
- Input wiring and output wiring shall be separated to improve noise sensibility.
- The protective earth (PE) must be connected to the  $\perp$  terminal or chassis.
- Remote ON/OFF control lines shall be twisted or used shielded wires. Separate from load line.
- Output current of each terminal screw shall be less than 40A for HWS300P. And shall be less than 60A for HWS600P.

### HWS300P Panel Side (Common HWS600P)

#### • Basic connection

Connect “CNT” terminal to “TOG” terminal with the attached connector.

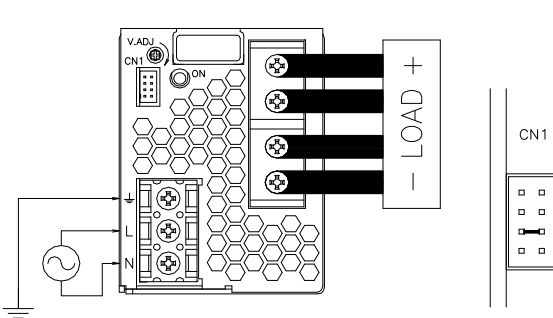

#### • PF signal output required

Open collector method shown below shall be used.  
 “TOG” terminal is ground for “PF” terminal.

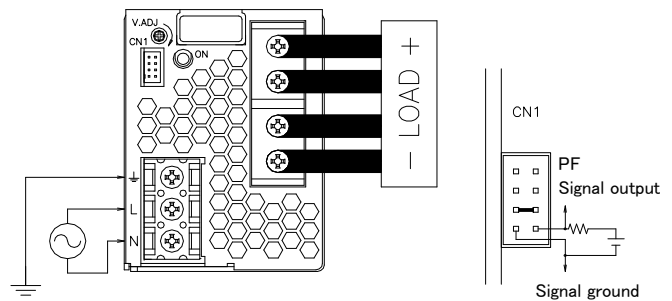

#### • Remote ON/OFF control required

“TOG” terminal is ground for “CNT” terminal.  
 Connect an outside signal between CNT-TOG.

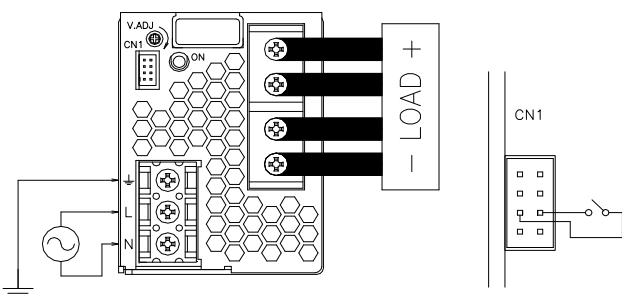



## 6. Functions and Precautions

### 6-1. Input Voltage Range

Input voltage range is single phase 85 ~ 265VAC (47 ~ 63Hz) or 120 ~ 330VDC. Input voltage, which is out of specification, may cause unit damage. Rated input voltage for safety standard application is 100 ~ 240VAC(50/60Hz).

### 6-2. Output Voltage Range

Output voltage is set to the rated voltage value at shipment. V.ADJ trimmer on the front panel side is used to adjust the output voltage within the range specified.

Output voltage range is within  $-20\% \sim +10\%$  of rated output voltage.

To turn the trimmer clockwise, the output voltage will be increased. Take note when the output voltage is increased excessively, over voltage protection (OVP) function may trigger and output voltage will be shut down.

When output voltage increased, average output power and peak output power have to use less than specification.

### 6-3. Over Voltage Protection (OVP)

The OVP function (Inverter shutdown method, manual reset type) is provided. OVP function operates within 115-135% of the rated output voltage value, and the output will be shut down when OVP function trigger. To reset OVP, remove the input of power supply for a few minutes, and then re-input. Or, use CNT reset ( remote ON/OFF : OFF to ON). OVP value is fixed and not to be adjusted externally.

Never apply more than rated output voltage to output terminal, which may lead damage to power supply. In the case of inductive load, use decoupling diode at output line.

### 6-4. Delay Shut Down

This product have a delay shut down function provided to protect power supply and equipment at the time of the consecutive peak current. When the product operate peak current for more than 5 seconds, delay shut down function operates and the output will be shut down.

To reset delay shut down, remove the input of power supply for a few minutes, and then re-input. Or, use CNT reset ( remote ON/OFF : OFF to ON).

Delay Shut Down Time value is fixed and not to be adjusted externally.

Use it about the peak electricity in specifications range. The details see at "4-14. Output Peak Power".

### 6-5. Over Current Protection (OCP)

The OCP function (manual reset type) is provided. Output will be shut down in condition over current or output short-circuit.

To reset OCP, remove the input of power supply for a few minutes, and then re-input. Or, use CNT reset ( remote ON/OFF : OFF to ON).

Also avoid over current condition or output short-circuit. Otherwise the product will be damage.

OCP value is fixed and not to be adjusted externally.

### 6-6. Over Temperature Protection (OTP)

The OTP function (manual reset type) is provided. When ambient or internal temperature rises abnormally, OTP function operates and output will be shut down. To reset OTP, remove the input and cool it down. Then re-input.

Or, use CNT reset after cool it down( remote ON/OFF : OFF to ON).

### 6-7. Low Output Detection Circuit (PF)

Low output voltage detection circuit is provided. Power Fail (PF) signal will turn "High" level to indicate the abnormal status when the output voltage becomes within 65 ~ 80% of rated value caused by either the drop or brownout of the input voltage or OCP, OVP, Delay Shut Down and OTP etc function operation. When the built-in Fan of this power supply unit stops, PF signal will turn to "High". The PF signal is isolated from input and output by a photo-coupler. It uses the open collector method shown in below.

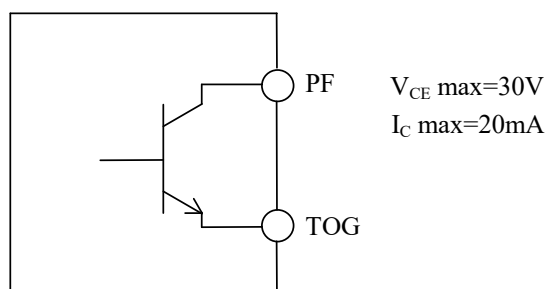

### 6-8. Remote ON/OFF Control

Remote ON/OFF control is provided.

Using this function, output ON/OFF is allowed to control without input voltage ON/OFF. The output is turned to ON when TOG and CNT terminals are shorted, and the output is turned to OFF when these terminals are opened. When the function is not used, connect TOG and CNT terminals. The standards for this function are as follows. “TOG” terminal is return for “CNT” terminal.

- (1) TTL compatible. The maximum input voltage to CNT terminal is 12V, and the maximum allowable reverse voltage is  $-1.0V$ . The sink current for CNT terminal is 3.5mA.
- (2) A switch and relay or a transistor can be used as ON/OFF switch.
- (3) Remote ON/OFF control circuit is isolated from the input and output by a photo-coupler and can be controlled regardless of the output potential (+ or -). Connect TOG terminal to ground of control signal.

#### The mode of control

CNT Level for TOG Terminal	Output	Built-in Fan
Short or L (0V - 0.8V)	ON	Rotate
Open or H (2.4V - 12V)	OFF	Stop

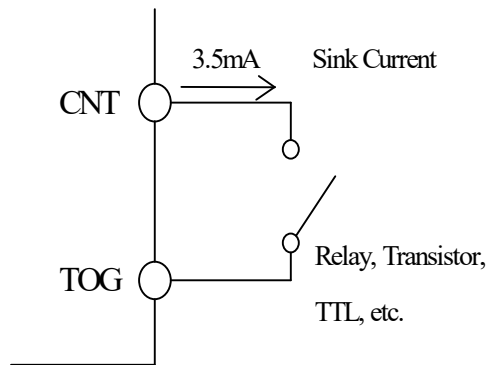

### 6-9. Output Ripple & Noise

The standard specification for maximum ripple value is measured specified measurement circuit (JEITA-RC9131A). When load lines are longer, ripple becomes larger. In this case, electrolytic capacitor, film capacitor, etc. might be necessary to use across the load terminal. The output ripple cannot be measure accurately if the probe ground lead of oscilloscope is too long.

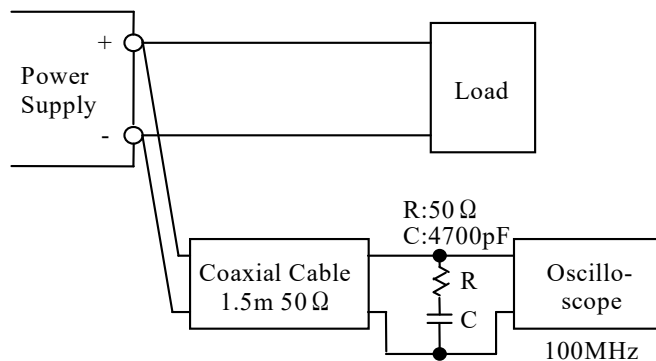

### 6-10. Series Operation

For series operation, both method (A) and (B) are possible.  
 There might be a step in the output rise waveform during series operation.

Method (A)

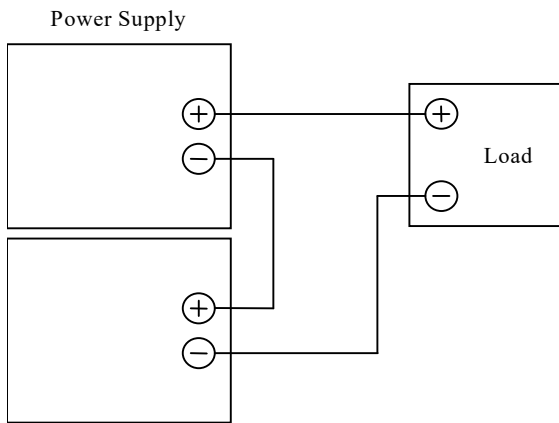

Method (B)

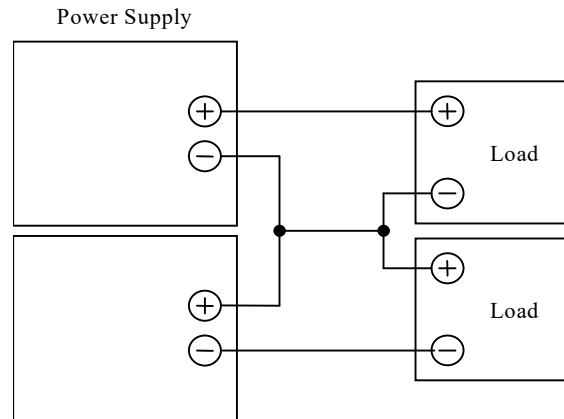

### 6-11. Parallel Operation

There are operation Mode (A) and (B).  
 As for HWS300P, Mode (B) is possible. As for HWS600P, Mode (A) and (B) are possible.

(A) To Increase the Output Current(only as for HWS600P)

Current balancing function is provided. Connecting PC to PC terminal and COM to COM terminal, the current balancing function activates and output current of each power supply is equivalently supplied to load. Wires to PC terminals, COM terminals shall be as short as possible and same length and twisted.

Parallel operation is possible up to 2 units.

1. Adjust the output voltage of each power supply to be same value within 100mV.
2. Use same length and type of wires for all load lines.
3. Peak output current and average output current use less than specification for all paralleled models.

(B) To Use as a Backup Power Supply

1. Adjust the output voltage of each power supply to be same value.
2. Set power supply output voltage higher by the forward voltage drop of diode.
3. Use within the specifications for output voltage and output power.

(A) To Increase the Output Current  
 (only as for HWS600P)

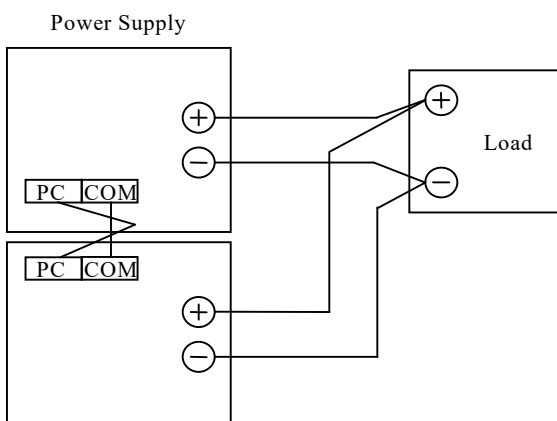

(B) To Use as a Backup Power Supply

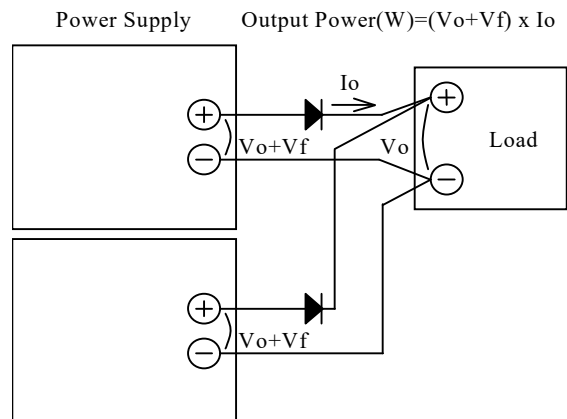

### 6-12. Isolation Test

Isolation resistance between output and  $\perp$  (Frame ground) shall be more than  $100M\Omega$  at 500VDC and between output and CNT·PF shall be more than  $10M\Omega$  at 100VDC. For safety operation, voltage setting of DC isolation tester must be done before the test. Ensure that it is fully discharged after the test.

• Output ~  $\perp$  (Frame ground) : 500VDC  $100M\Omega$  or more

• Output ~ CNT · PF : 100VDC  $10M\Omega$  or more

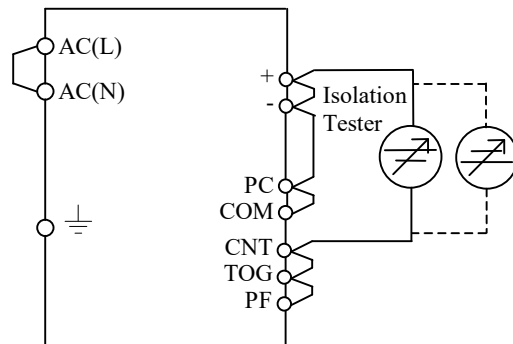
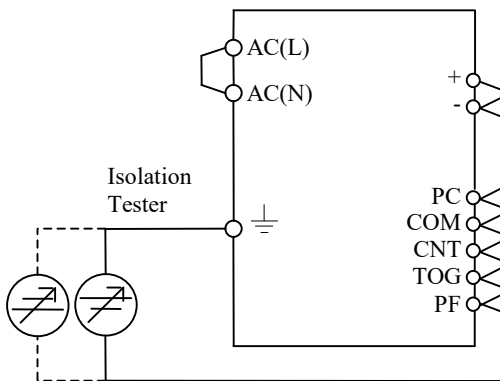

Note 1. "PC" and "COM" are NC in HWS300P.

### 6-13. Withstand Voltage

This series is designed to withstand 3.0kVAC between input and output, 2.5kVAC between input and  $\perp$  (Frame ground), 500VAC between output and  $\perp$  (Frame ground), and 100VAC between output and CNT·PF terminal each for 1 minute. When testing withstand voltage, set current limit of withstand voltage test equipment at 20mA.

(Output- $\perp$  (Frame ground) and Output-CNT·PF: 100mA).

The applied voltage must be gradually increased from zero to testing value and then gradually decreased for shut down. When timer is used, the power supply may be damaged by high impulse voltage at timer switch on and off. Connect input and output as follows.

In the test by state of output open, there is a thing that output voltage is generated momentarily.

Input ~ Output (dotted line) : 3.0kVAC 1min. (20mA)

Input ~  $\perp$  (Frame ground) (solid line) : 2.5kVAC 1min. (20mA)

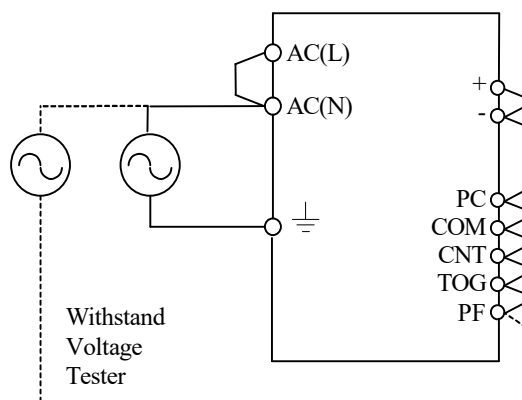

Output ~ ⏏ (Frame ground) : 500VAC 1min. (100mA)

Output ~ CNT· PF : 100VAC 1min. (100mA)

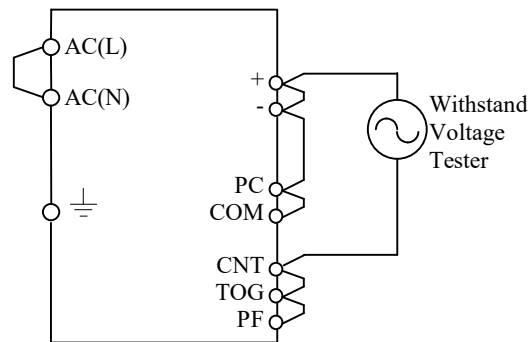
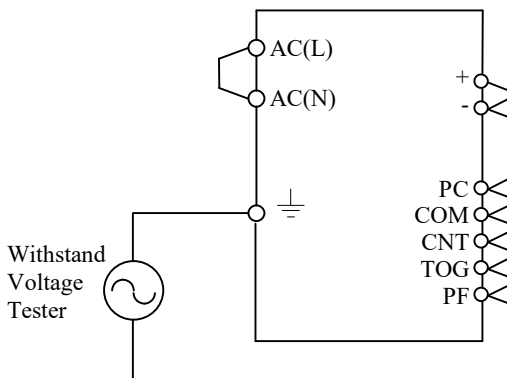

Note 1, "PC" and "COM" are NC in HWS300P.

Note 2, This product have monolithic ceramic capacitor in secondary circuit to frame ground.

Some of the withstand voltage tester may generate high voltage at the matching with monolithic ceramic capacitor and may cause the unit damage.

So, please check the waveform of test voltage.

### 6-14. Output Peak Power

This product must be use to satisfy (a) and (b).

Allowable peak output operating time is less than 5sec.

When the product operate peak power for more than 5 sec, the delay shut down function operates and the output will shut down.

Peak output power and average output power use less than specification.

Peak output power is limited depending on Duty. The details see at (b).

The product might be damage to use beyond the limits of (a) and (b).

When using pulse load, a noise may be heard from power supply unit. Please evaluate and check before using.

#### (a) Expression of relations

##### A formula about Duty

$$Duty = \frac{\tau}{T} \times 100(\%)$$

##### A formula about average output power

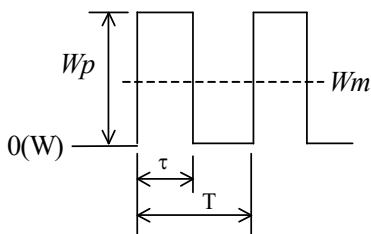

$$W_{avg} \geq W_m = \frac{W_p \times \tau}{T}$$

$W_p$  : Peak output power ( W )  
 $W_{avg}$  : Average output power of Specification ( W )  
 $W_m$  : Average output power ( W )

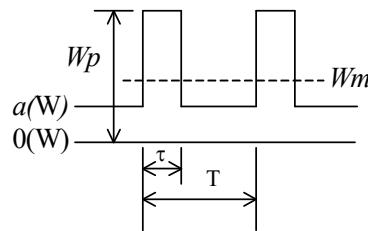

$$W_{avg} \geq W_m = \frac{(W_p - a) \times \tau}{T} + a$$

$\tau$  : Pulse width of peak output power ( sec )  
 ( Operating time at peak output )  
 $T$  : Period ( sec )  
 Duty : The duty is pulse width of peak output power of one period(%)

**(b) Peak output power VS Duty**  
HWS300P

Vin:100VAC(dotted line)  
Vin:200VAC(solid line)

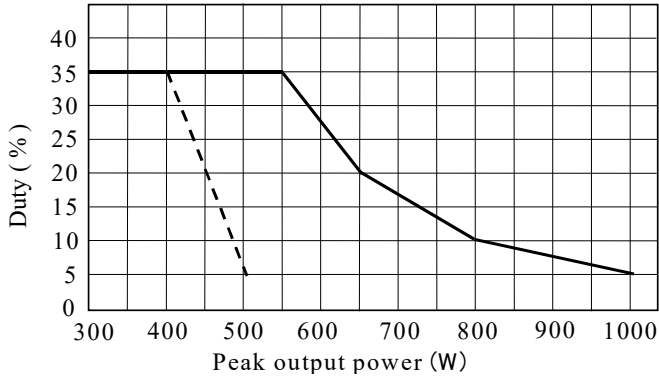

HWS600P

Vin:100VAC(dotted line)  
Vin:200VAC(solid line)

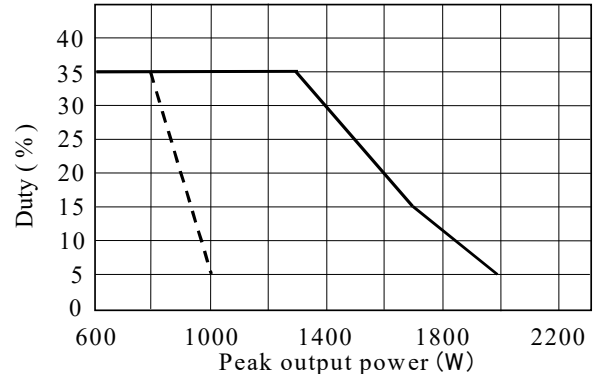

## 7. Mounting Directions

### 7-1. Output Derating according to the Mounting Directions.

Recommended standard mounting method is (A). Method (B) is also possible. Refer to the derating below.

HWS300P

(A) Standard Mounting

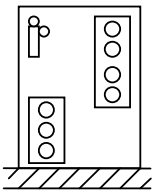

(B)

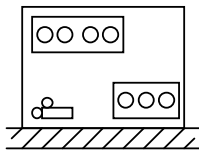

(C) Inhibit

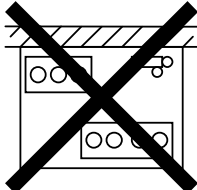

(D) Inhibit

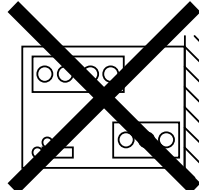

HWS600P

(A) Standard Mounting

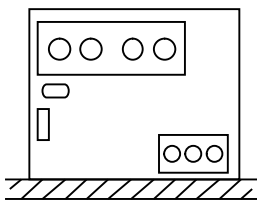

(B)

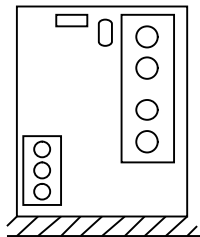

(C) Inhibit

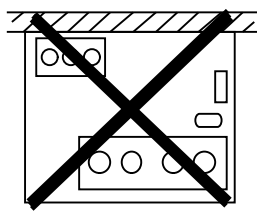

(D) Inhibit

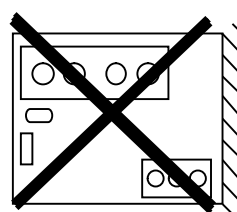

### 7-2. Output Derating

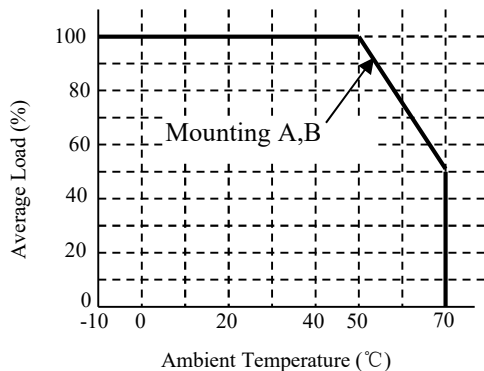

Ta(°C)	Average Load (%)	
	Mounting(A)	Mounting(B)
-10 ~ +50	100	
+70	50	

Note 1, Peak power does not have the derating.

### 7-3. Mounting Method

- (1) Forced air-cooling type power supply.  
This power supply has ventilating holes on the front and back side panels. Keep these two areas freely as much as possible.
- (2) The maximum allowable penetration is 6mm.  
Incomplete thread of mounting screw should not be penetrated.
- (3) Recommended torque for mounting screw :  
M4 screw : 1.27 N · m ( 13.0kgf · cm )

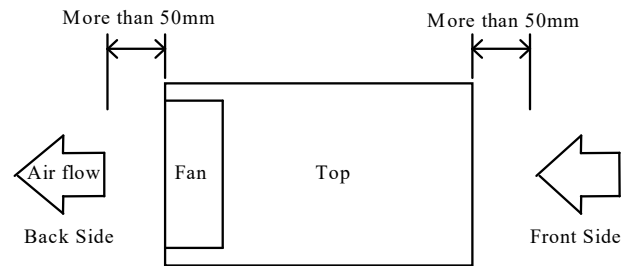

### 8. Wiring Method

- (1) The output load line and input line shall be separated to improve noise sensitivity.
- (2) Use all lines as thick and short as possible to make lower impedance.
- (3) Attaching a capacitor to the load terminals can eliminate noise.
- (4) For safety and EMI considerations, connect  $\perp$  terminal to the mounting set ground terminal.
- (5) Recommended torque for the terminal ;  
 HWS600P Output terminal (M5 screw) : 2.50 N · m (25.5kgf · cm )  
 HWS300P Input, Output terminal & HWS600P Input terminal (M4 screw) : 1.27 N · m (13.0kgf · cm )

#### [ The PHD connector manufacture method ]

This product is using SPHD-001T-P0.5 or SPHD-002T-P0.5 connector made from JAPAN SOLDERLESS TERMINAL MFG CO LTD.

Regarding to manufacture of a connector, it becomes the regulation as following.

#### a). Applicable Wire and Crimping tool

Wire size to use for SPHD-001T-P0.5 is AWG#26 ~ AWG#22 and insulation outer diameter is  $\phi$  1.0 ~  $\phi$  1.5 mm.

Wire size to use for SPHD-002T-P0.5 is AWG#28 ~ AWG#24 and insulation outer diameter is  $\phi$  0.9 ~  $\phi$  1.5 mm.

Crimping tool is as blow.

Crimping tool	Crimping applicator	Dies
AP-K2 or AP-KS	MKS-LS-10 or MKS-L-10	SPHD-001-05/SPHD-002-05

#### b). Crimping Operation

The reference value of wire strip is 2.3mm. As wire strip length differs depending on type of wire and crimping method , decide the best wire strip length considering processing condition. When wire is stripped, do not damage or cut off wire conductores.

Table of crimp height

SPHD-001T-P0.5

Wire Size	Insulation O.D (mm)	Crimp height (mm)	
		Conductor part	Insulation part
AWG#26	1.3	0.60 ~ 0.70	1.7
AWG#24	1.5	0.65 ~ 0.75	1.8
AWG#22	1.4	0.70 ~ 0.80	1.8

SPHD-002T-P0.5

Wire Size	Insulation O.D (mm)	Crimp height (mm)	
		Conductor part	Insulation part
AWG #28	1.2	0.55 ~ 0.60	1.6
AWG #26	1.3	0.60 ~ 0.65	1.7
AWG #24	1.5	0.62 ~ 0.67	1.8

Note 1. Crimp height at wire barrel should be set to pre-determined dimensions.

Note 2. Adjust crimp height at wire insulation barrel to the extent that wire insulation is slightly pressed, and set it so that crimping is not excessivery.

Note 3. Crimping condition at wire insulation barrel is as below Fig.1.

Note 4. For AWG#28,#26,#24, use UL1007 type. For AWG#22, use UL1061 type.

Fig.1

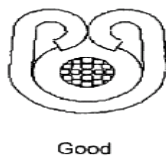
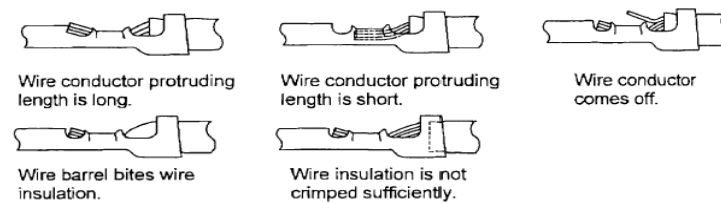

Fig.2: Examples of defective crimping



Check of crimping appearance visually for correct crimping as referring to above Fig.2  
 Check the tensile strength at crimped part when operation finishes.

Table of tensile strength at crimped part.  
 SPHD-001T-P0.5

Wire size	Requirement N min.	Actual value N
AWG#26	20	39.2 ~ 45.1
AWG#24	30	68.6 ~ 74.5
AWG#22	40	92.1 ~ 96.0

SPHD-002T-P0.5

Wire size	Requirement N min.	Actual value N
AWG#28	15	27.0~34.3
AWG#26	20	44.1~48.0
AWG#24	30	66.6~71.5

**c). Inserting contact into housing**

Inserting crimped contact into housing

- (1) Do not apply any pulling force to crimped part, and insert contact parallel to housing.
- (2) Insert contact into housing without stopping to innermost.
- (3) Check secure locking per each insertion by pulling wire softly in order to check that contact does not come off housing. Besides, check whether there is the backlash in the direction of insertion axis.

Defect example of slating insertion

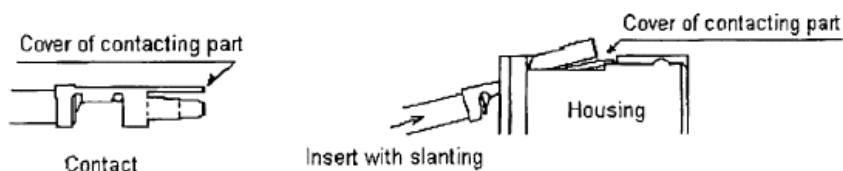

**d). Mating and Unmating Connector**

- (1) Inserting connector

Hold receptacle housing securely and insert into header straight against to header post until click sounds.

- (2) Unmating connector

Hold all wires securely and fix receptacle housing by fingers so as to pry, and then, withdraw it on the mating axis.

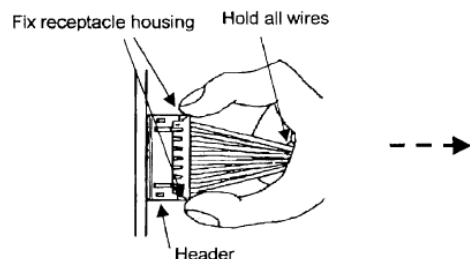

**e). Routing of Wire**

Routing wire so as not to apply external force to connector except force to such an extent that wire slightly buckles, considering an enough length to route and fixing of wire.



## **9. The life expectancy**

The life of the power supply depends on the life of the built-in aluminum electrolytic capacitor being used and mounted fan. Each life is described in reliability data.

The life of the aluminum electrolytic capacitor varies depending on the method of mounting the power supply, the load current, and the ambient temperature. Please refer to "Electrolytic Capacitor Lifetime".

The life of the fan depends on the fan intake or exhaust temperature. Please refer to "Fan Life Expectancy".

Please do not use the product which passed over the life expectancy. There is a risk of unexpected output shutdown and specifications may not be satisfied.

Please contact us for maintenance or exchange the product which passed over the life expectancy.

## **10. External Fuse Rating**

Refer to the following fuse rating when selecting the external fuses that are to be used on input line. Surge current flows when line turns on. Use slow-blow or time-lag type fuse, not fast-blow fuse. Fuse rating is specified by in-rush current value at line turn-on. Do not select the fuse according to input current (RMS.) values under the actual load condition.

HWS300P : 12A

HWS600P : 20A

## **11. Before concluding that the unit is at fault...**

Before concluding that the unit is at fault, make the following checks.

- (1) Check if the rated input voltage is connected.
- (2) Check if the wiring of input and output is correct.
- (3) Check if the I/O terminal connection is properly tightened by regulated torque.
- (4) Check if the wire thickness is enough.
- (5) Check if the output voltage control (V.adj) is properly adjusted. OVP might be triggered and output is shut down.
- (6) If use function of the Remote ON/OFF control, check if the Remote ON/OFF control connector is not opened.  
If in open condition, power supply will not output.
- (7) Check if the built-in Fan is not stopped. Is Fan stopped by something irregulars or etc?  
If Fan stops, the PF signal turn "High" level and OTP might be activated.
- (8) Power supply has ventilating holes on the front and back panels. Check if there is any irregulars or dust, etc.
- (9) Is the chassis of power supply hot abnormally? The output is shut down by OTP operation.  
Please re-input after the unit to cool down sufficiently.
- (10) Check if the output current and output power does not over specification.
- (11) Audible noise may be heard when input voltage waveform is not sinusoidal.
- (12) Audible noise may be heard during dynamic load operation.

## **12. Range of free warranty**

This product is warranted for a period of 5 years from the date of shipment.

For damages occurring at normal operation within this warranty period, repair is free of charge.

### **13. CE MARKING / UKCA MARKING**

#### **CE MARKING**

CE Marking, when applied to a product or packing material for a product covered by this handbook, indicates compliance with the Low Voltage Directive, EMC Directive and RoHS Directive.

#### **UKCA MARKING**

UKCA Marking, when applied to a product or packing material for a product covered by this handbook, indicates compliance with the Electrical Equipment (Safety) Regulations, Electromagnetic Compatibility Regulations and Restriction of the Use of Certain Hazardous Substances in Electrical & Electronic Equipment Regulations.