

# KWS5A-25A Series Instruction Manual

## BEFORE USING THE POWER SUPPLY UNIT

Be sure to read this instruction manual thoroughly before using this product. Pay attention to all cautions and warnings before using this product. Incorrect usage could lead to an electrical shock, damage to the unit or a fire hazard.

### DANGER

Never use this product in locations where flammable gas or ignitable substances are present.

### INSTALLATION WARNING

- When installing, ensure that work is done in accordance with the instruction manual. When installation is improper, there is risk of electric shock and fire.
- Installation shall be done by Service personnel with necessary and appropriate technical training and experience. There is a risk of electric shock and fire.
- Do not cover the product with cloth or paper etc. Do not place anything flammable around. This might cause damage, electric shock or fire.

### WARNING on USE

- Do not touch this product or its internal components while circuit in operation, or shortly after shutdown. You may receive a burn.
- While this product is operating, keep your hands and face away from it as you may be injured by an unexpected situation.
- For products with no cover, do not touch them as there are high-voltage and high temperature parts inside. Touching them might cause injury such as electric shock or burn.
- There are cases where high voltage charge remains inside the product immediately after the input is cut off. Therefore, do not touch even if they are not in operation as you might get injured due to high voltage and high temperature. You might also get electric shock or burn.
- Do not make unauthorized changes to this product nor remove the cover as you might get an electric shock or might damage the product. We will not be held responsible after the product has been modified, changed or dis-assembled.
- Do not use this product under unusual condition such as emission of smoke or abnormal smell and sound etc. Please stop using it immediately and shut off the product. It might lead to fire and electric shock. In such cases, please contact us. Do not attempt repair by yourself, as it is dangerous for the user.
- Do not operate and store these products in environments where condensation occurs due to moisture and humidity. It might lead fire and electric shock.
- Do not drop or apply shock to this product. It might cause failure. Do not operate these products mechanical stress is applied.
- When necessary, this products is to be repaired only by us or our authorized agents. It is important that this product cannot be used in hazardous environments (facilities such as nuclear power control system or life support equipment) without our written consent.

### CAUTION on MOUNTING

- Confirm connections to input/output terminals are correct as indicated in the instruction manual before switching on.
- Input voltage, Output current, Output power, ambient temperature and ambient humidity should be kept within specifications, otherwise the product will be damaged.
- Input line, please use the wires as short and thick as possible.
- Do not use this product in special environment with strong electromagnetic field, corrosive gas or conductive substances and direct sunlight, or places where product is exposed to water or rain.
- Mount this product properly in accordance with the instruction manual, mounting direction and shall be properly be ventilated.
- Please shut down the input when connecting input and output of the product.
- When installing in environment where conductive foreign, dust and liquid may be present, please consider penetration of above foreign material in the power supply by installing filter, to prevent trouble or malfunction.

 **CAUTION on USE**

- Product individual notes are shown in the instruction manual. If there is any difference with common notes individual notes shall have priority.
- Before using this product, be sure to read the catalog and instruction manual. There is risk of electric shock or damage to the product or fire due to improper use.
- Input voltage, Output current, Output power, ambient temperature and ambient humidity should be kept within specifications, otherwise the product will be damaged, or cause electric shock or fire.
- If the built-in fuse is blown, do not use the product even after replacing the fuse, as there is risk of abnormality inside. Be sure to request repair to our company.
- For products without built-in protection circuit (element, fuse, etc.), insert fuse at the input to prevent smoke, fire during abnormal operation.

As for products with built-in protection circuit, depending on usage conditions, built-in protection circuit might not work. It is recommended to provide separate proper protection circuit.

- For externally mounted fuse do not use other fuses aside from our specified and recommended fuse.
- This product was made for general purpose electronic equipment use and is not designed for applications requiring high safety (such as extremely high reliability and safety requirements. Even though high reliability and safety are not required, this product should not be used directly for applications that have serious risk for life and physical safety.

Take sufficient consideration in fail-safe design (such as providing protective circuit or protective device inside the system, providing redundant circuit to ensure no instability when single device failure occurs).

- When used in environments with strong electromagnetic field, there is possibility of product damage due to malfunction.
- When used in environment with corrosive gas (hydrogen sulfide, sulfur dioxide, etc.) , there is possibility that they might penetrate the product and lead to failure.
- When used in environments where there is conductive foreign matter or dust, there is possibility of product failure or malfunction.
- Provide countermeasure for prevention of lightning surge voltage as there is risk of damage due to abnormal voltage.
- Connect together the frame ground terminal of the product and the ground terminal of the equipment for safety and noise reduction. If these ground is not connected together, there is risk of electric shock.
- Parts with lifetime specifications (built-in fan electrolytic capacitor) are required to be replaced periodically. Set the overhaul period depending on the environment of usage and perform maintenance. Also, note that there are cases when EOL products cannot be overhauled.
- Take care not to apply external abnormal voltage to the output. Especially, applying reverse voltage or overvoltage more than the rated voltage to the output might cause failure, electric shock or fire.
- This product is designed under condition Material group IIIb, Pollution Degree (PD): PD2, Over Voltage category (OVC): OVCI and Class of equipment: Class II.  
This product is designed to be accessible only to service technicians as part of indoor use device.
- Never operate the product under over current or short-circuit conditions for more than 30 seconds, or outside its specified Input Voltage Range. Insulation failure, smoking, burning or other damage may occur.
- This product has used Power Thermistor to protect the circuit from Inrush Current. Frequent repetition of input might cause damage to internal components because of generating surge current.

### **Note**

- Take note that traces of sheet metal processing be left in our power supplies.
- When disposing product, follow disposal laws of each municipality.
- Published EMI (CE, RE) or immunity is the result when measured in our standard measurement conditions and might not satisfy specification when mounted and wired inside end-user equipment.  
Use the product after sufficiently evaluating at actual end-user equipment.
- When exporting our products, apply for necessary permissions as required by rules and regulations of Foreign Exchange and Foreign Trade Control Act.
- Catalogue, contents of the instruction manual may be changed without a prior notice. Refer to latest catalogue or instruction manual.
- Reproduction or reprinting the instruction manual or its portion is forbidden without our permission.

### **LONG-TERM STORAGE METHOD AND LONG-TERM STORAGE PERIOD**

- Please keep the product in carton box.
  - Please do not apply excessive vibration, shock or mechanical stress applied directly to the product.
  - Please keep away from direct sunlight.
  - For long-term storage temperature and humidity, the following conditions shall be used as a guideline :
    - Temperature range : 5°C ~ 30°C
    - Humidity range : 40% ~ 60%RHPlease keep away from the places where temperature and humidity can change drastically.  
It can cause condensation on the product or deterioration.
  - For long-term storage period, we recommend to use within 2 years after receiving the product.
    - There is tendency that the leakage current of an aluminium electrolytic capacitor may increase when stored without using for a long time.
      - This phenomenon can be improved by applying voltage to the aluminum electrolytic capacitor to reduce the increased leakage current through the self-recovery effect of the electrolyte.
      - For products that have been received for more 1 year, please check lead oxidation and solderability.
      - For reference, before using products that have been stored for a very long time, please warm-up first for 30 minutes or more without taking load.
- < Criterion of warm up voltage condition >
- (1)Implementation period : 1 year or above after the delivery
  - (2)Electrical continuity condition
    - Input voltage : Rating
    - Load : 0A
    - Ambient temperature : Normal temperature
    - Time : 30 minutes or more

### 1. Model name identification method

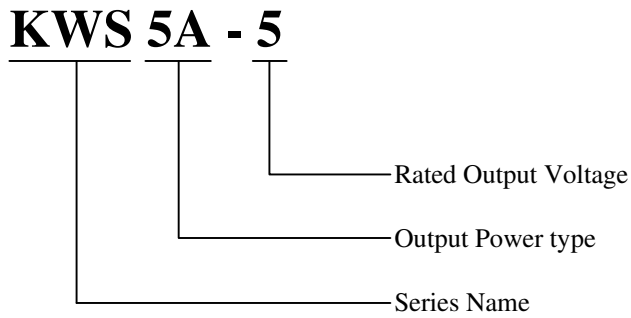

### 2. Terminal Explanation

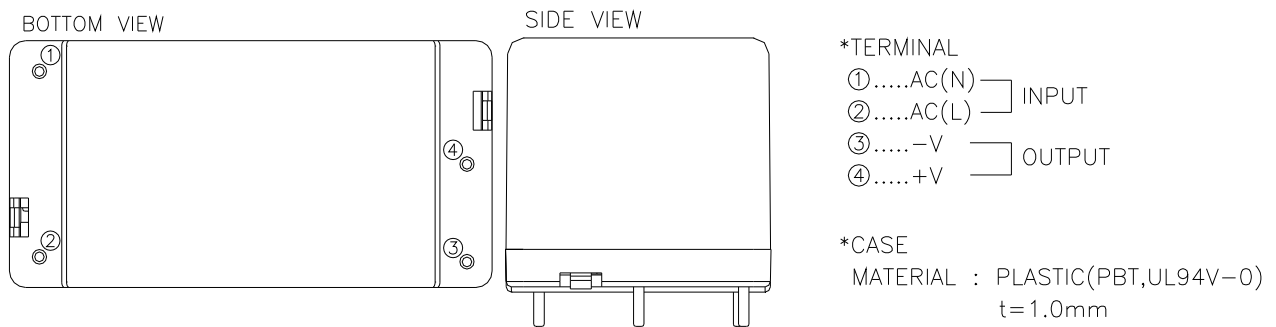

### 3. Connecting method

Pay attention to the input wiring. If it is connected to wrong terminal, the power supply will be damaged.

- Input must be off when making connections.

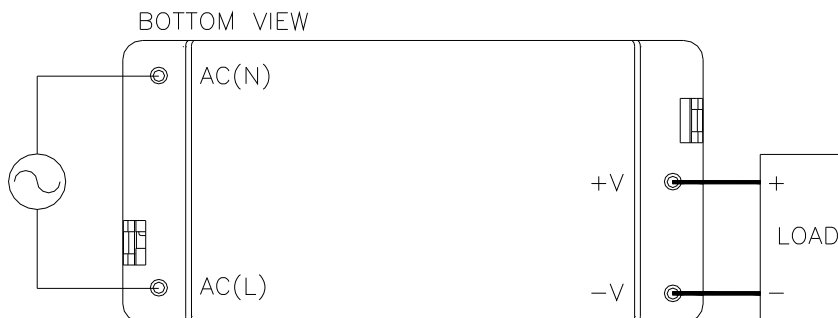

## 4. Block Diagram

KWS5A/KWS10A

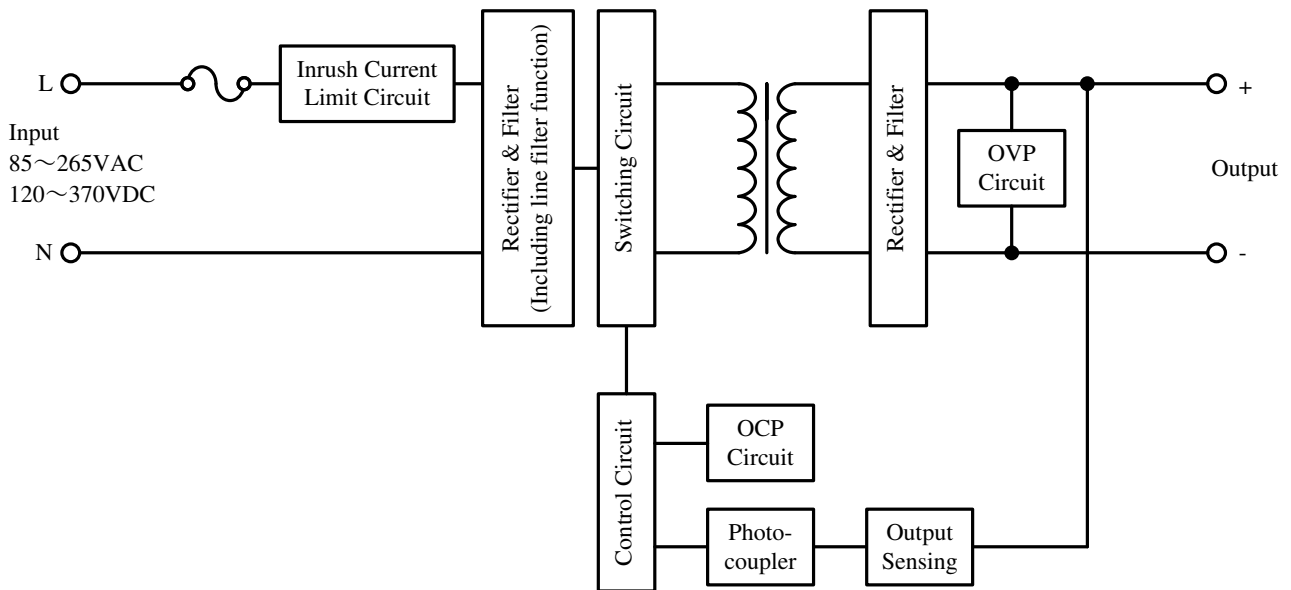

KWS15A/KWS25A

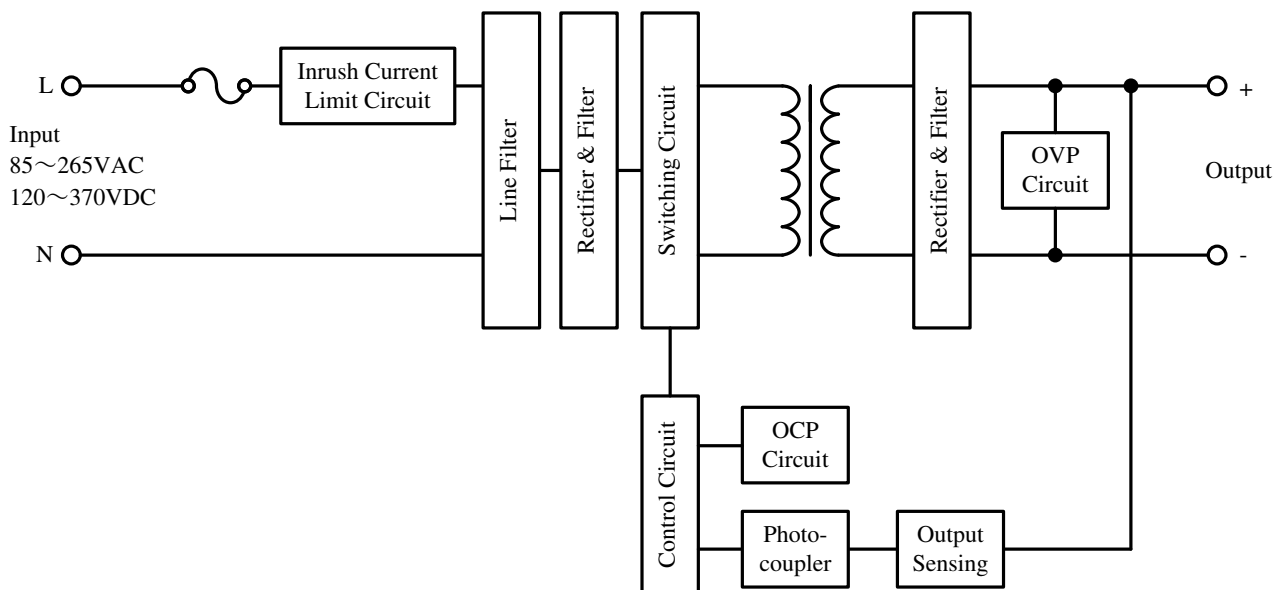

- Circuit topology : Flyback topology
- Switching frequency : KWS5A,KWS10A,KWS15A,KWS25A : 130kHz (fixed)
- Fuse rating : KWS5A,KWS10A : 1A  
 KWS15A : 2A  
 KWS25A : 3.15A

## 5. Sequence time chart

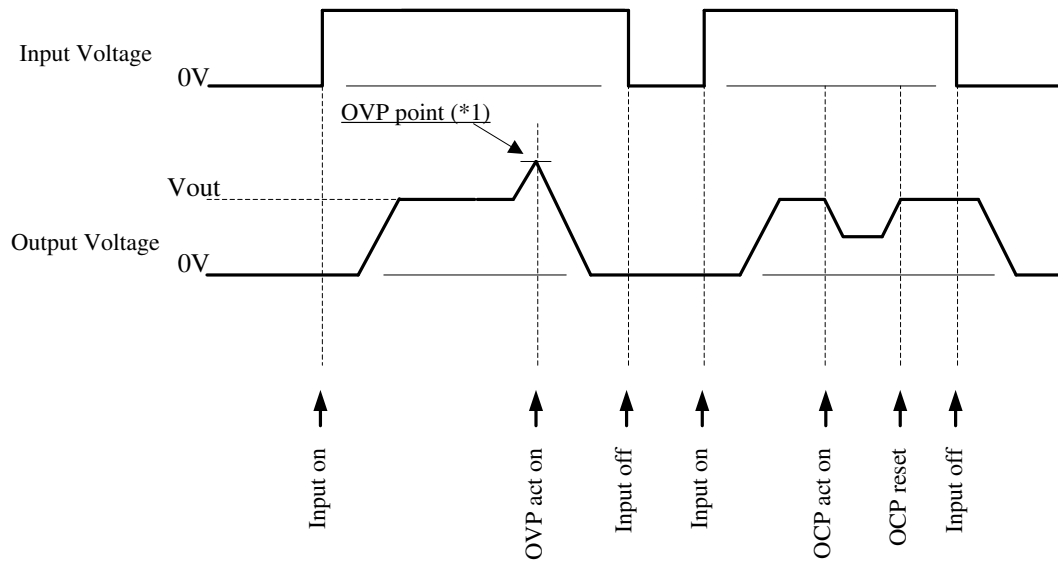

(\*1) OVP Point

5V	: 115% - 140%
12V	: 115% - 153%
15V	: 115% - 150%
24V	: 115% - 142%

## 6. Explanation of Functions and Precautions

### 6-1. Input Voltage Range

Input voltage range is single phase 85-265VAC (47-440Hz) or 120-370VDC.

Input voltage, which is out of specification, might lead unit damage. For cases where conformance to various safeties required, described as 100-240VAC (50-60Hz).

### 6-2. Inrush Current

Power thermistor is used for limiting the inrush current.

Power thermistor method is used for these models. Higher current will flow at higher ambient temperature or input turn on condition. Please select input switch or external fuse carefully. The inrush current value specified in the specification is under cold start condition (at 25°C).

### 6-3. Over Voltage Protection (OVP)

The over voltage protection (OVP) circuit with zener diode clamp system is built in. Over 115% of nominal voltage will clamp the output. If the output voltage is lowered due to the over voltage application, the output will not resume. Replacement of the power supply unit is necessary.

### 6-4. Over Current Protection (OCP)

Fold back limit and Hiccup mode with automatic recovery. These products provide the Hiccup mode with automatic recovery. OCP function operates when the output current exceeds 105% of maximum DC output current of specification. The outputs will be automatically recovered when the overload condition is canceled. Never operate the unit under over current or shorted conditions, which may leads unit. OCP setting is fixed and not to be adjusted externally.

### 6-5. Output Ripple & Noise

The standard specification for maximum ripple value is measured according to measurement circuit specified by JEITA-RC9131B. When load lines are longer, ripple will becomes larger. In this case, electrolytic capacitor, film capacitor, etc. might be necessary to use across the load terminal.

The output ripple cannot be measure accurately if the probe ground lead of oscilloscope is too long.

For start up at low temperature ambient, that is no overshoot at start up and output ripple noise specification can be met after one minute.

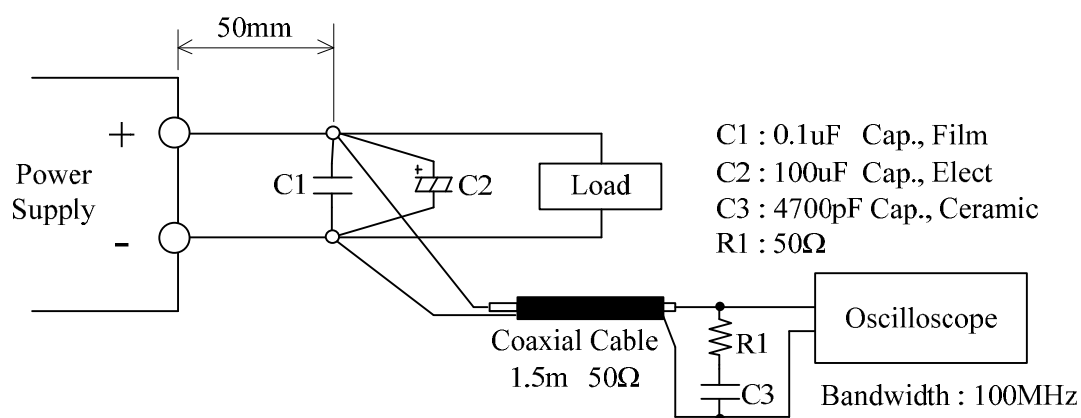

### 6-6. Series Operation

For series operation, either method (A) or (B) is possible.

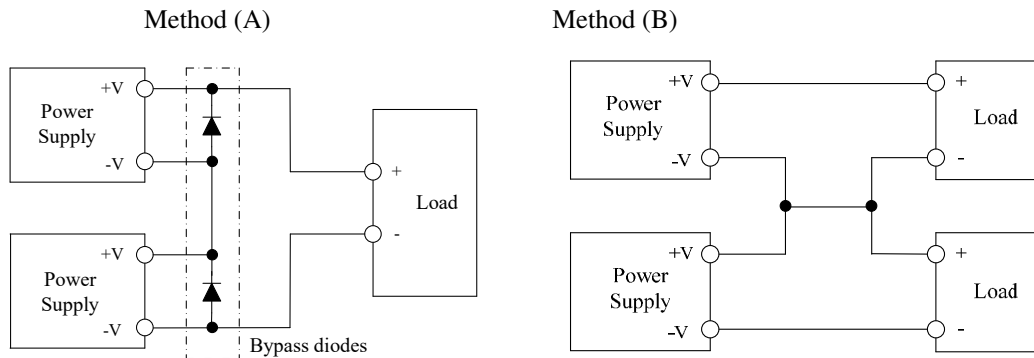

Note :In case of method (A), connect bypass diodes. If not, the unit might cause damage.

Please select a bypass diode with maximum forward current rating more than output load current.  
 And maximum reverses voltage must withstand each power supply output voltage.

### 6-7. Conducted Emission & Radiated Emission

These products can meet EN55011/EN55022-A, FCC-A, VCCI-A without any external parts.

If needs to meet EN55011/EN55022-B, FCC-B, VCCI-B, need to add external parts.

#### CLASS A

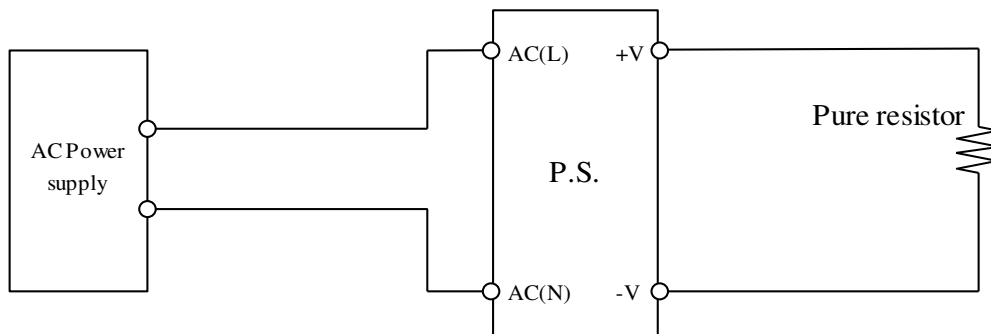

#### CLASS B

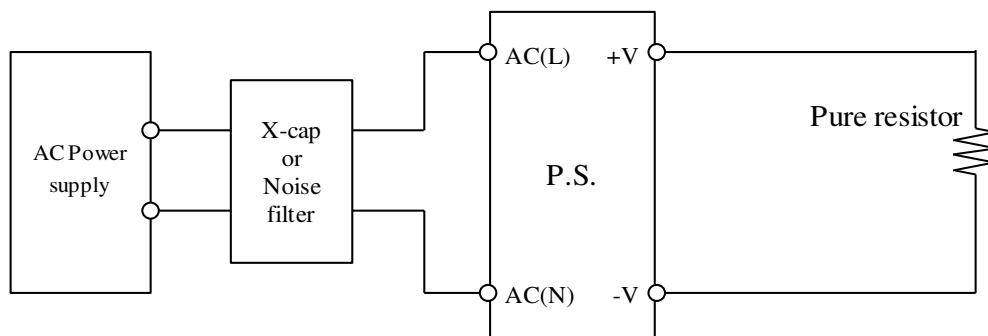

X-cap recommended : Rated voltage:More than 265VAC Capacitance:More than 0.1uF.

Noise filter recommended : RSEG-2001 (TDK-Lambda).



**6-8. Isolation Test**

Isolation resistance between Input – Output is more than  $100M\Omega$  at 500VDC. For safety operation, voltage setting of DC isolation tester must be done before the test. Ensure that the unit is fully discharged after the test.

- Input – Output : 500VDC More than  $100M\Omega$

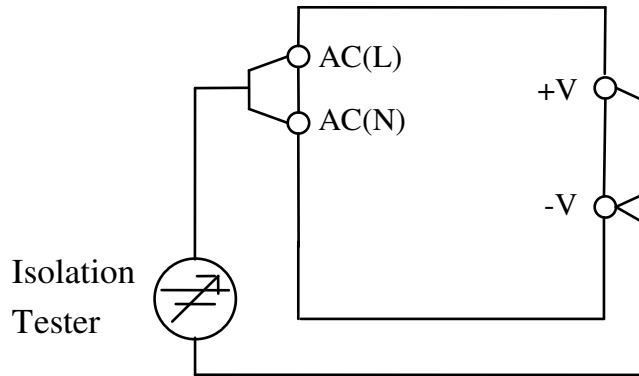

**6-9. Withstand Voltage**

This series is designed to withstand 3.0kVAC between input and output for 1 minute. When testing withstand voltage, set current limit of withstand voltage test equipment at 20mA. The applied voltage must be gradually increased from zero to testing value and then gradually decreased for shut down. When timer is used, the power supply may be damaged by high impulse voltage at switch on and off timing. Connect input and output as follows.

- Input – Output : 3.0kVAC, 1min (20mA)

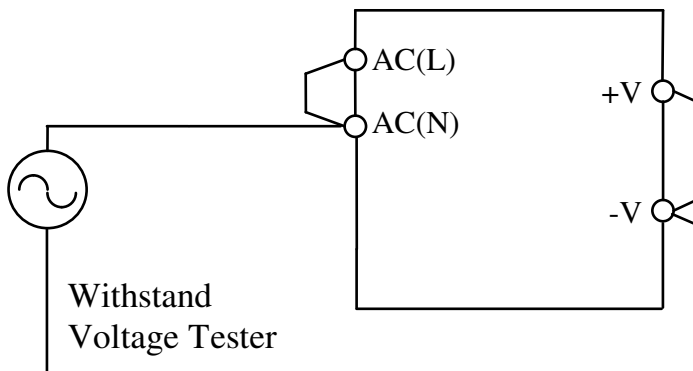

## 7. Mounting Method

### 7-1. Mounting Method

#### (1) Mounting Holes on PCB

The mounting hole position is in Fig.7-1.

(2) To ensure conformance to various safety standards, creepage distance and clearance between the primary and the secondary of the PWB for power module mounting shall be considered.

Keep creepage distance and clearance between the primary and the secondary needs more than 6 mm.

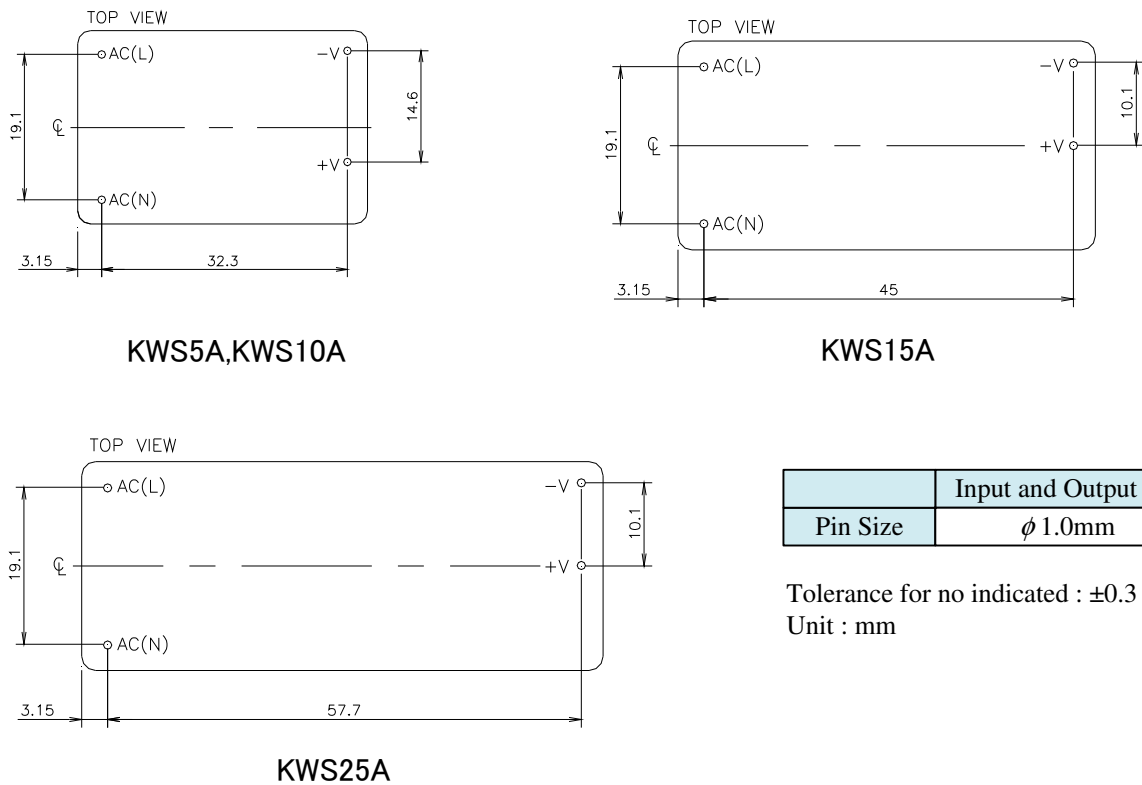

Fig.7-1 The mounting hole position

#### (3) Stress to the pins

- Do not apply excessive stress to the power module input and output pins, it will easily cause internal connections broken.
- Do not pull or bend pins strongly in order to avoid risk of solder crack.

**7-2. Recommended Soldering Condition**

Recommended soldering conditions are as follows.

(1) Soldering Dip

Dip condition : 260°C within 10 seconds up to 1 time.

Pre-heat condition : 110°C for 30 - 40 seconds.

(2) Soldering Iron

350°C within 3 seconds up to 1 time/PIN.

Note) Soldering time changes according to heat capacity of soldering iron, pattern on printed circuit board etc.  
 Please confirm actual performance.

**7-3. Recommended Cleaning Condition**

Recommended cleaning condition after soldering are as follows.

(1) Cleaning Solvent

IPA (isopropyl alcohol)

(2) Cleaning Procedure

Use brush and dry the solvent completely before use.

**7-4. Output Derating according to the Mounting Directions**

The standard mounting is direction (A). Direction (B), (C), (D) and (E) are also possible.

Direction (A)~(E) are same derating. Direction (F) is not recommended for using.

There should be enough consideration for airflow so that heat does not accumulate around the power supply vicinity.

Refer to the output derating below, load (%) is percent of maximum output current value in a rated output voltage.

■ Mounting direction

(A) Standard Mounting

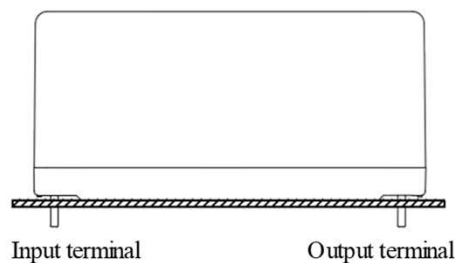

(B)

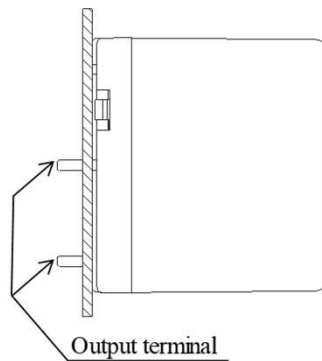

(C)

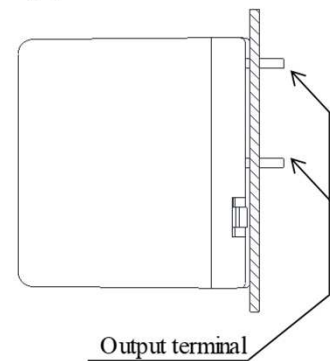

(D)

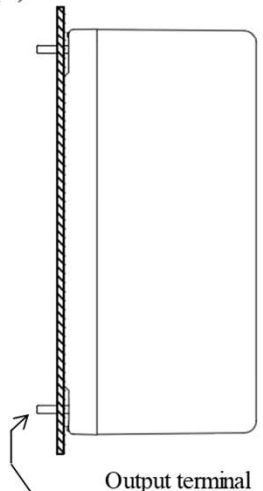

(E)

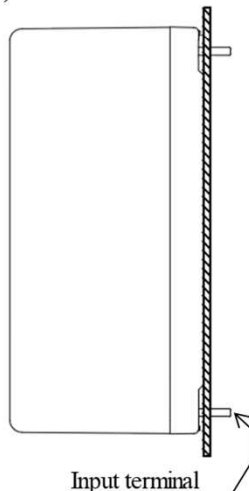

(F)

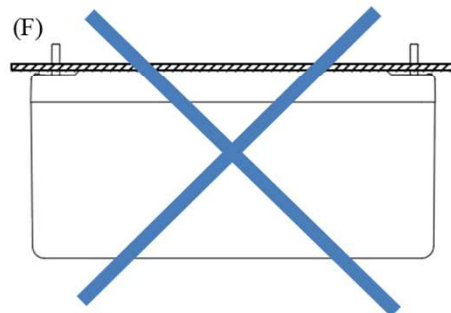

■ Output Derating

**KWS5A**

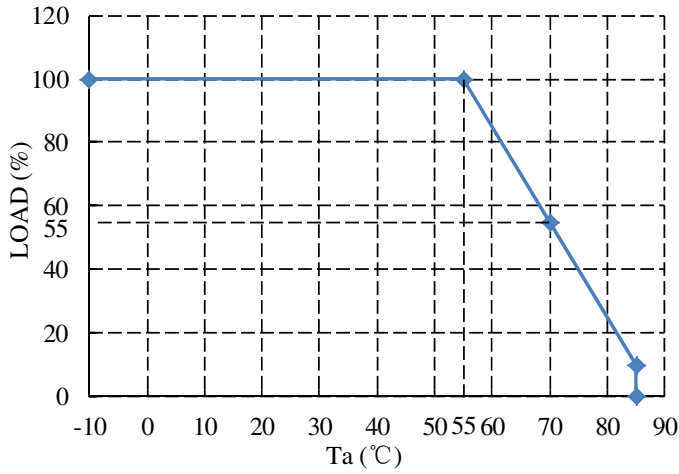

— 5V,12V,15V,24V

5V,12V,15V,24V	
Ta(°C)	Load(%)
-10	100
55	100
70	55
85	10

**KWS10A,KWS15A,KWS25A**

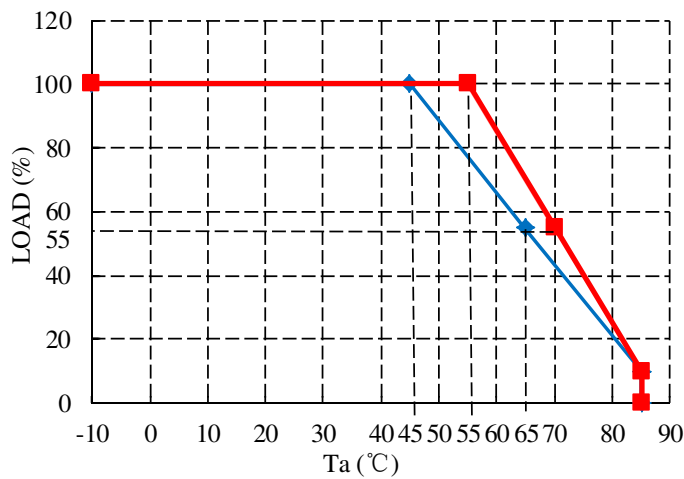

— 5V  
 — 12V,15V,24V

5V	
Ta(°C)	Load(%)
-10	100
45	100
65	55
85	10

12V,15V,24V	
Ta(°C)	Load(%)
-10	100
55	100
70	55
85	10

**7-5. Output Derating according to the Input Voltage**

Load (%) is percent of maximum output current value in a rated output voltage.

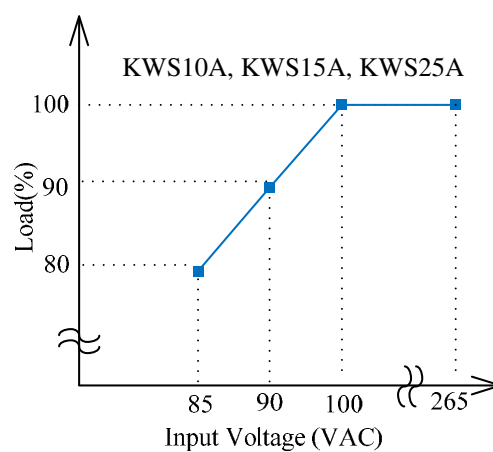
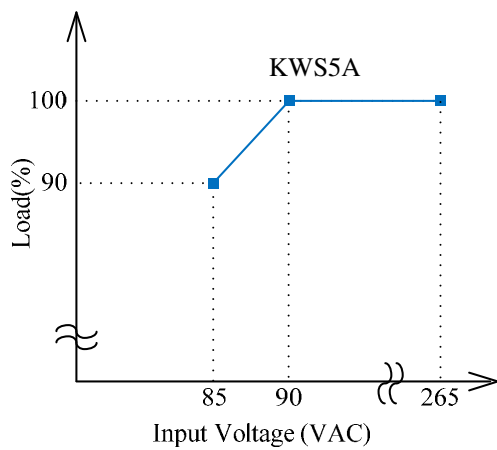

## 8. External Fuse Rating

Refer to the following fuse rating when selecting the external input fuse.  
 Surge current flows when input turn on. Use slow-blow fuse or time-lag fuse. Fast-blow fuse can not be used.  
 Fuse rating is specified by inrush current value at input turn on.  
 Do not select the fuse according to actual input current (rms.) values.

KWS5A, KWS10A : 1.0A  
 KWS15A : 2.0A  
 KWS25A : 3.15A

## 9. Before concluding that the unit is at fault...

Before concluding that the unit is at fault, make the following checks.

- (1) Check if the rated input voltage is connected.
- (2) Check if the PCB pattern thickness is enough.
- (3) Check if the output current and output power does not over specifications.
- (4) Audible noise can be heard when input voltage waveform is not sinusoidal wave.
- (5) Audible noise can be heard during Dynamic-Load operation.
- (6) Ensure that large capacitor is not connected on the output side.

Please use within maximum capacitance shown below.

Maximum external capacitance				
MODEL	5V	12V	15V	24V
KWS5A	2,000uF	820uF	820uF	330uF

Maximum external capacitance				
MODEL	5V	12V	15V	24V
KWS10A	2,000uF	1,000uF	1,000uF	390uF(150uF)*

Maximum external capacitance				
MODEL	5V	12V	15V	24V
KWS15A	2,000uF	1,000uF	1,000uF	560uF

Maximum external capacitance				
MODEL	5V	12V	15V	24V
KWS25A	4,700uF	2,200uF	2,200uF	1,500uF(680uF)*

\* : The value in parentheses " ( ) " is the external capacity of the constant current load.

## 10. The life expectancy

The life of the power supply depends on the life of the built-in aluminum electrolytic capacitor.  
 The life is described in reliability data.  
 The life of the aluminum electrolytic capacitor varies depending on the method of mounting the power supply, the load current, and the ambient temperature.  
 Please refer to "Electrolytic Capacitor Lifetime".  
 Please do not use the product which passed over the life expectancy.  
 There is a risk of unexpected output shutdown and specifications may not be satisfied.  
 Please exchange the product which passed over the life expectancy.

## 11. Warranty Period

This product is warranted for a period of 3 years from the date of shipment.  
 For damages occurring at normal operation within this warranty period, repair is free of charge.

## **12. CE MARKING / UKCA MARKING**

### **CE MARKING**

CE Marking, when applied to a product or packing material for a product covered by this handbook, indicates compliance with the Low Voltage Directive and RoHS Directive.

### **UKCA MARKING**

UKCA Marking, when applied to a product or packing material for a product covered by this handbook, indicates compliance with the Electrical Equipment (Safety) Regulations and Restriction of the Use of Certain Hazardous Substances in Electrical & Electronic Equipment Regulations.