

PFH500 Series

Instruction Manual

BEFORE USING THE POWER SUPPLY UNIT

Be sure to read and understand this instruction manual thoroughly before using this product. Pay attention to all cautions and warnings before using this product. Incorrect usage could lead to an electrical shock, damage to the unit or a fire hazard.

DANGER

Never use this product in locations where flammable gas or ignitable substances are present. There are potential risks of igniting these substances caused by arcing.

WARNING

- Do not touch this product or its internal components while circuit is live, or shortly after shut down. There may be high voltage or high temperature present and you may receive an electric shock or burn.
- While this product is operating, keep your hands and face away from it as you may be injured by an unexpected situation.
- Do not make unauthorized changes to this product, otherwise you may receive an electric shock. It will also void the product warranty.
- Do not drop or insert anything into the product. It might lead to a failure, fire or electric shock.
- Do not use this product if abnormal conditions such as emission of smoke and/or abnormal smell, etc... are present. It might lead to fire and/or electric shock. In such cases, please contact TDK-Lambda. Do not attempt to repair by yourself, as it is dangerous for the user.
- Do not operate these products in the presence of condensation. It might lead to fire or electric shock.

CAUTION

- This power supply is designed and manufactured for use within an end product such that it is accessible only to trained SERVICE ENGINEERS.
- Confirm that the connections to input/output terminals, and signal terminals are correct as specified in this instruction manual before turning on the power.
- Input voltage, Output current, Output power, ambient temperature, case temperature, and ambient humidity should be kept within the specifications, otherwise the product may be damaged.
- Do not operate or store this product in an environment where condensation can occur. Waterproof treatment or special storage and handling is necessary.
- The equipment has been evaluated for use in a Pollution Degree 2 environment.
- Do not use this product in environment with a strong electromagnetic field, corrosive gas or conductive substances.
- For applications, which require very high reliability, such as nuclear related equipment, medical equipment, traffic control equipment, etc., it is necessary to provide a fail-safe mechanism in the end equipment.
- Do not inject abnormal voltages into the output terminals or signal terminals of this product. The injection of reverse voltage or over voltage exceeding nominal output voltage into these terminals can damage the internal components of the product.
- Never operate the product under over-current or short circuit conditions. Failure or other damage may occur.
- The output voltage of this power supply unit is considered to be a hazardous energy level (The voltage is 2 V or more and the electric power is 240 W or more). It must not be made accessible to users. Protection must be provided for Service Engineers against indirect contact with the output terminals and/or to prevent tools being dropped across them. While working on this product, the AC input power must be switched off, and the input, output, +VBUS, and -VBUS terminal voltages should be at a safe level.
- The application circuits and their parameters are for reference only. Be sure to verify effectiveness of these circuits and their parameters before finalizing the circuit design.
- Use a Fast-Blow external fuse to each module to ensure safe operation and compliance with the safety standards to which it is approved. The recommended input fuse rating within the instructions is as follows: 10A, 250V fast acting fuse. The breaking capacity and voltage rating of this fuse may be subject to the end use application.

⚠ CAUTION

- This information in this document is subject to change without prior notice. Please refer to the latest version of the data sheet, etc., for the most up-to date specifications of the product.
- No part of this document may be copied or reproduced in any form without prior written consent TDK-Lambda.



Contents

BEFORE USING THE POWER SUPPLY UNIT	1
1 Model Name Identification Scheme.....	5
1.1 Ordering Table	5
2 Module Pinout (Pin Side-Up).....	6
3 Circuit Block Diagram	7
4 Sequence Timing Diagram	8
5 Terminal Connecting Method	9
5.1 F1 External Input Fuse	10
5.2 C1 (1 μ F); C4 (1 μ F); C5 (2.2 μ F) Film Capacitor or Class X Safety Capacitor	10
5.3 L1 (6.3 mH); L2 (6.3 mH) Common Mode Choke	11
5.4 C2 (3300 pF); C3 (3300 pF) Ceramic Capacitor or Class Y Capacitor	11
5.5 R1 (470 k Ω , 2 W); R3 (470 k Ω , 2 W); R4 (470 k Ω , 2 W)	11
5.6 C6 (470 pF); C7 (470 pF) Ceramic Capacitor or Class Y Capacitor	11
5.7 Electrolytic Bulk Capacitors: C9 (470 μ F); C10 (470 μ F)	11
5.8 C11 (470 pF); C12 (470 pF)	12
5.9 C13 (0.1 μ F, 50 V~100 V Ceramic Capacitor)	12
5.10 C14 (40 μ F, 50 V~100 V or (4) 10 μ F Ceramic capacitors in parallel)	12
5.11 C15; C16 – Output Electrolytic Capacitors	13
5.12 R2	14
5.13 RL Inrush Relay (12 V Coil, 10 A / 277 Vac; 16 A / 125 Vac)	15
6 Explanation of Functions and Precautions	15
6.1 Input Voltage Range	15
6.2 Output Grounding Scheme	15
6.3 Output Voltage Adjustment Range	15
6.4 Inrush Current	18
6.5 Output Over Voltage Protection (OVP)	18
6.6 Boost (or VBUS) Over Voltage and Under Voltage Protection (BOVP/BUVP)	18
6.7 Over Current Protection (OCP)	18
6.8 Auto-Recovery Mode Option (Non-Latching)	19
6.9 Over Temperature Protection (OTP)	19
6.10 Remote Sensing	19
6.11 ON-OFF Control	20
6.12 Power Good Signal (PGood)	21

6.13	Auxiliary Bias Power	22
6.14	OPTIONAL Droop Load Share (Parallel Operation)	22
6.15	PMBus Communication	23
6.16	Ripple and Noise	24
6.17	Series Operation	25
6.18	Isolation Resistance	26
6.19	Withstand Voltage Test (Hipot Test)	26
7	Thermal Considerations and Mounting Method.....	28
7.1	Thermal Consideration	28
7.2	Thermal Test Setup	29
7.3	Output Current / Case Temperature Thermal Derating	29
7.4	Recommended Soldering Condition	31
7.5	Recommended Washing Condition	31
8	Troubleshooting Guide.....	32
9	Warranty Period.....	33
10	Appendix.....	34
10.1	EMI Conducted Emissions CISPR 32:2015 Class B Recommended Values	34
11	Document History	37

1 Model Name Identification Scheme

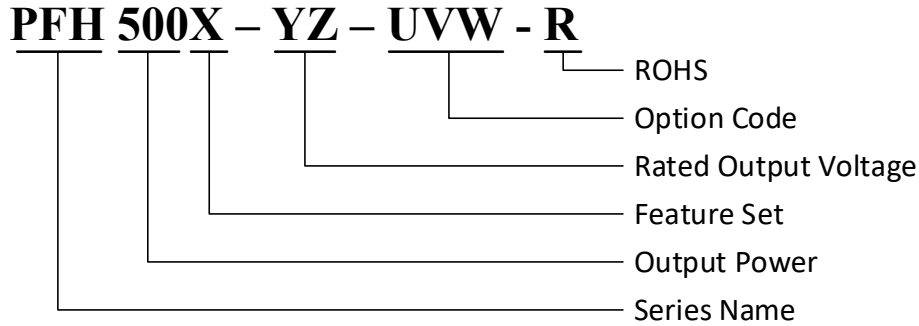

1.1 Ordering Table

X Feature Set	YZ Output	U Case Mounting	V Parallel Operation	W			Pin Length
				OVP (Default)	OCP (Default)	OTP (Default)	
F: Full Features A: 400 Hz Compatible*	12: 12 Vdc 28: 28 Vdc 48: 48 Vdc	0: Thru-Hole 1: Threaded	0: No Load Share D: Droop Load Share	Latching	Non-Latching	Non-Latching	0.240"
-UVW (OPTION CODE EXAMPLES)							
	-000	Thru-Hole	No Load Share	Latching	Non-Latching	Non-Latching	0.240"
	-0D0		Droop Load Share				
	-100	Threaded	No Load Share				
	-1D0		Droop Load Share				

*400 Hz input line frequency operation currently supported in 28 V output module. Consult factory on availability of other output voltages.

2 Module Pinout (Pin Side-Up)

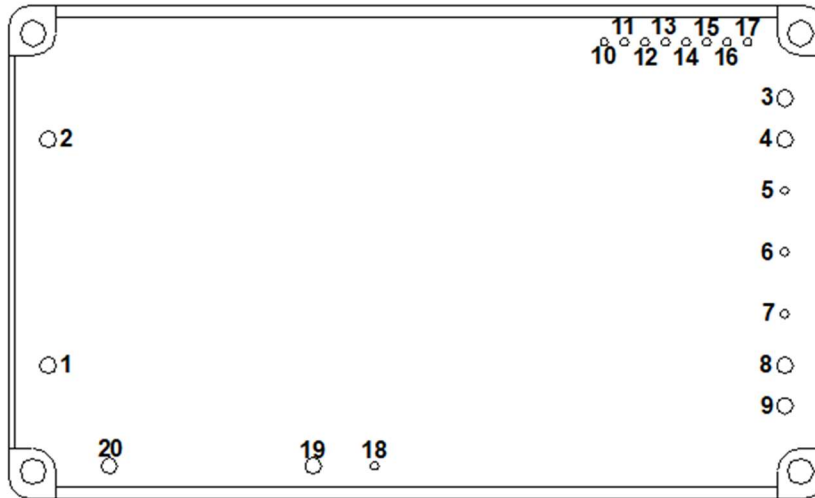

Pin	Function
1	AC(L)
2	AC(N)
3	Vout(-)
4	Vout(-)
5	On/Off
6	Trim
7	RS(+)
8	Vout(+)
9	Vout(+)
10	PGood
11	SGND
12	Aux Pwr
13	PMBus Clock
14	PMBus Data
15	PMBus Alert
16	PMBus Addr2
17	PMBus Addr1
18	Inrush Control
19	-VBUS
20	+VBUS

PIN #	PIN DESIGNATION	FUNCTION	PIN #	PIN DESIGNATION	FUNCTION
1	AC (L)	AC Input - Live Line	11	SGND	Secondary Signal Ground
2	AC (N)	AC Input - Neutral Line	12	Aux Pwr	Auxiliary Supply Output
3	Vout(-)	-Output Voltage (Return)	13	PMBus Clock	i2C Clock
4	Vout(-)	-Output Voltage (Return)	14	PMBus Data	i2C Data
5	On/Off	Output On/Off Pin	15	PMBus Alert	Alert Line
6	Trim	Output Voltage Adjust	16	PMBus Address 2	Address Lines
7	RS(+)	+Remote Sense Line	17	PMBus Address 1	Address Lines
8	Vout(+)	+Output Voltage	18	Inrush Control	Inrush Control pin
9	Vout(+)	+Output Voltage	19	-VBUS	-Boost Voltage
10	PGood	Power Good	20	+VBUS	+Boost Voltage

NOTE:

- Module case can be connected to Earth Ground through the M3 mounting holes.
- Spacing/clearance requirement between mounting screw and pin 20 (≥ 1 mm slot).
- Note that +VBUS and -VBUS terminals are primary voltage with high voltage rating (405 Vdc).
- Do not connect any load(s) across +VBUS and -VBUS terminals. Otherwise, it may damage the module.

3 Circuit Block Diagram

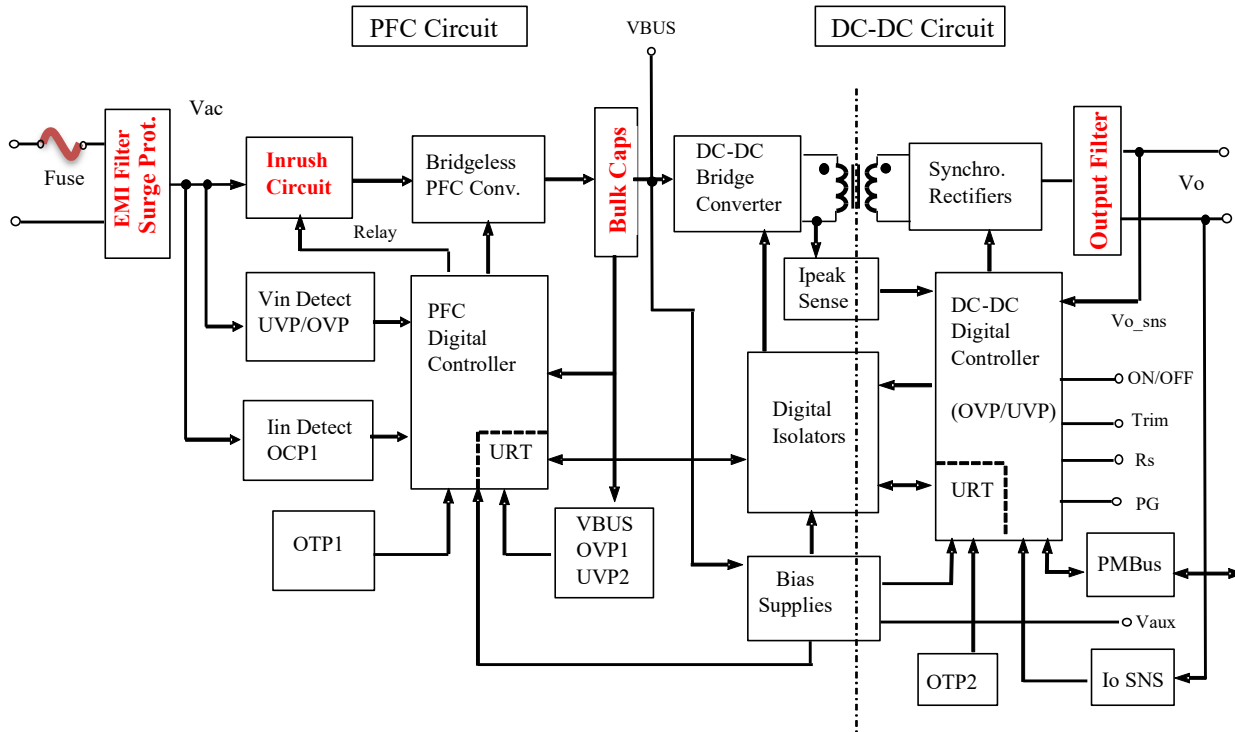

NOTE: The blocks with red font are the external components required for the operation of PFH module.

SWITCHING FREQUENCY		
PFC Converter (Fixed)	145 kHz	
DC-DC Converter (Fixed)		
Vo = 12 Vdc	135 kHz (Primary)	270 kHz (Secondary Ripple)
Vo = 28 Vdc	145 kHz (Primary)	290 kHz (Secondary Ripple)
Vo = 48 Vdc	165 kHz (Primary)	330 kHz (Secondary Ripple)
BIAS Converter	135 kHz	

4 Sequence Timing Diagram

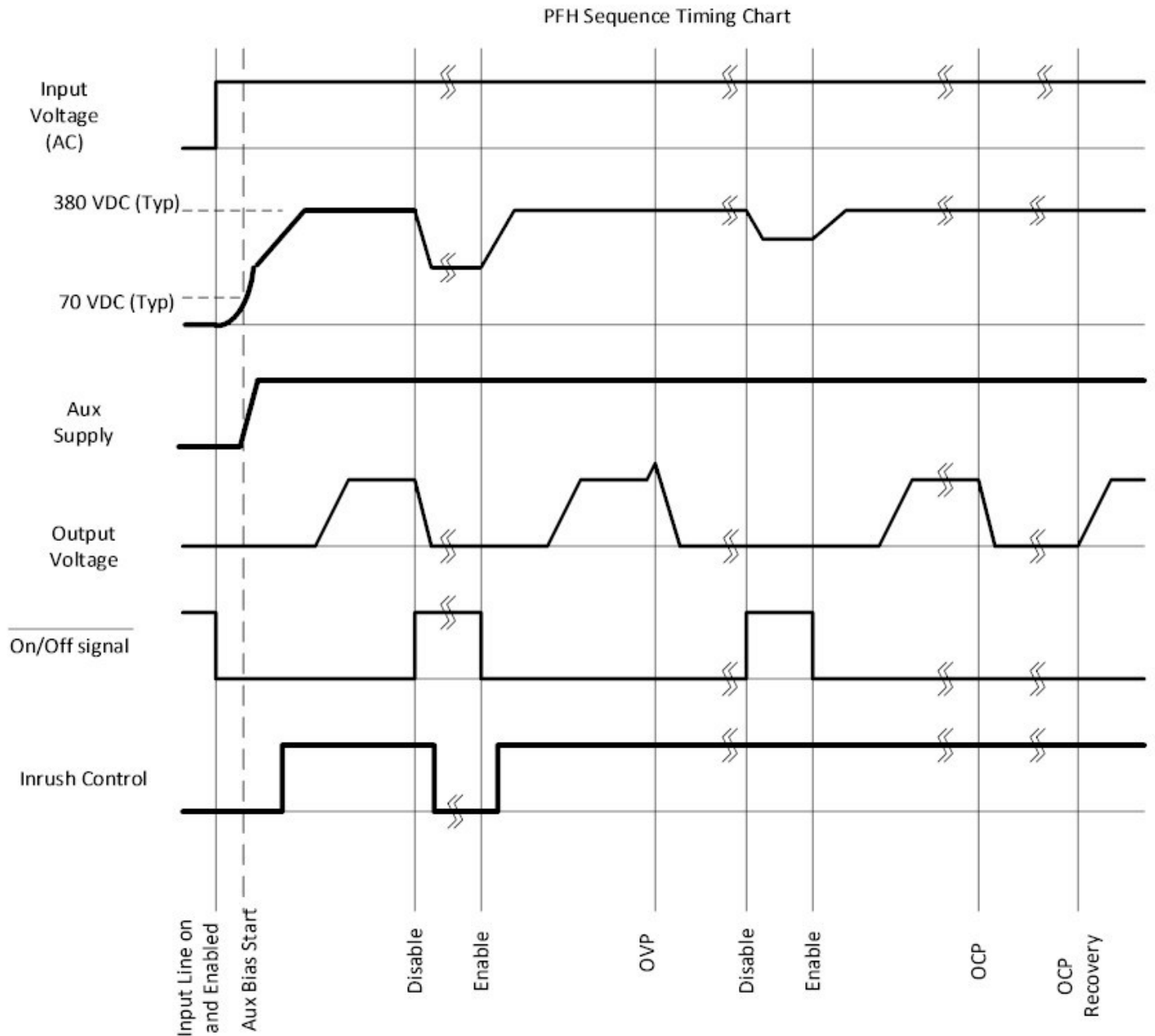

NOTE: PFH Series product has a remote ON/OFF pin (PIN# 5) that is referenced to SGND.

5 Terminal Connecting Method

In order to use the PFH500 series, this module must be connected with external components according to Figure 5-1. Pay attention to the wiring details. If the PFH module is wired incorrectly, the power module may be damaged.

The PFH Series module is designed for both convection and conduction cooling applications. Use a heat sink and fan(s) to remove the heat generated by operation at heavy loads. For selection of heat sink(s) and the heat sink heat transfer method, refer to the Power Module Application Note.

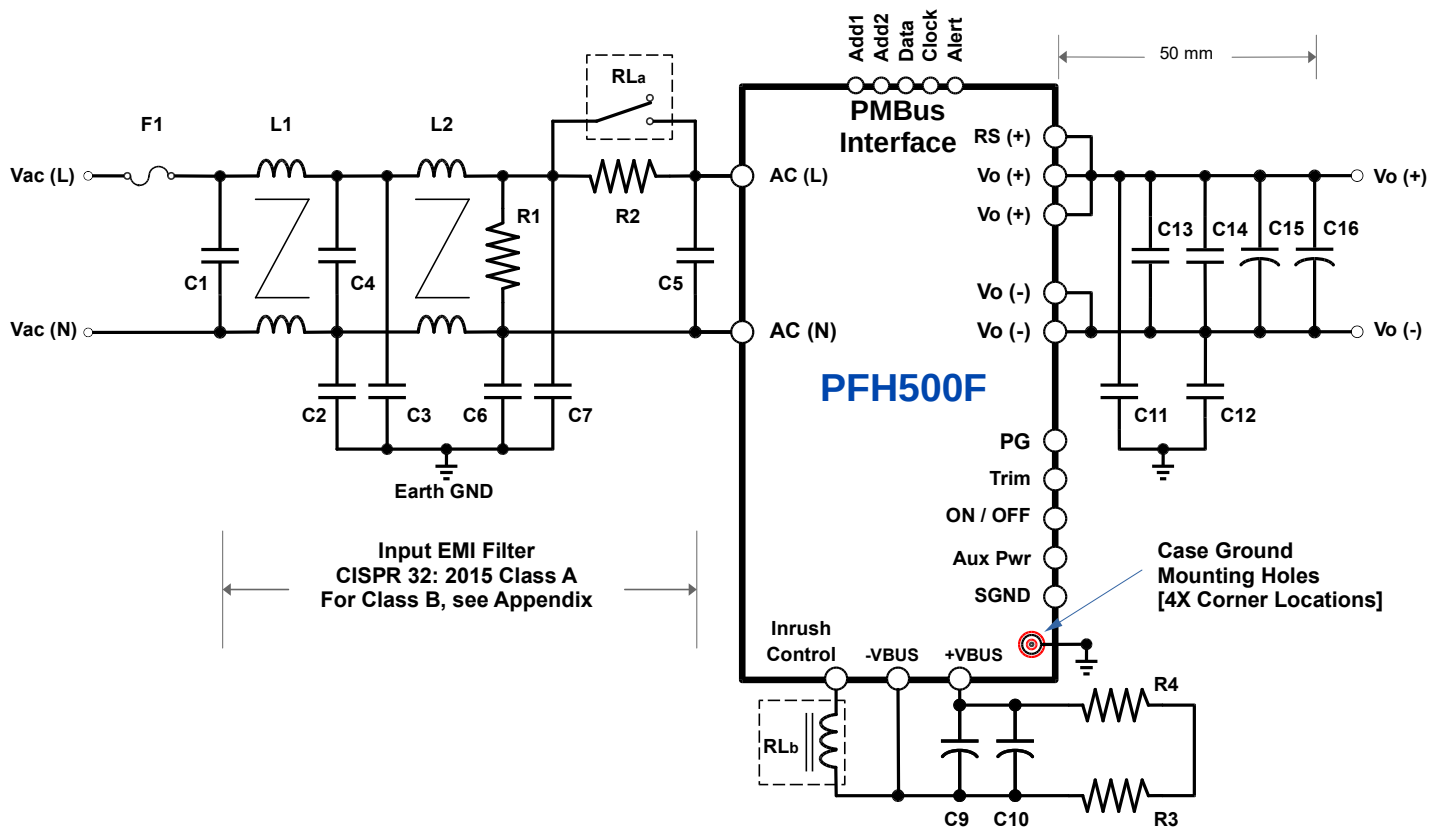

Fig. 5-1 Basic Connection

5.1 F1 External Input Fuse

PFH500 series module has no internal fuse. Use an external fuse to meet Safety Agency requirements.

PFH500 series modules were tested for safety agency certifications (UL, cUL, VDE, etc.) using 10A, 250 Vac, Fast-Acting line fuse. One Fast-Acting type fuse must be used for each PFH module.

When selecting a fuse, be aware the line inrush surge current will flow through the PFH module during initial line power application (or line power switch in). Check the I²t rating of the external power switch (or circuit breaker), and the external line fuse to make sure that the fuse will not blow, and/or the circuit breaker will not trip.

Recommended External Fuse : **10 A, 250 V (Fast Acting)**

Note: Select fuse based on rated voltage, rated current and surge current capability.

(1) Voltage Ratings

100 Vac line: AC125V
 200 Vac line: AC250V

(2) Current Ratings

Rated current is determined by the maximum input current based on operating conditions and can be calculated by the following formula:

$$I_{in} (\text{max}) = \frac{P_{out}}{V_{in} (\text{min}) \times \eta \times PF} (\text{Arms}) \quad (\text{Formula 5-1})$$

I_{in} (max) : Maximum Input Current
 P_{out} : Maximum Output Power
 V_{in} (min) : Minimum Input Voltage
 η : Efficiency
 PF : Power Factor

For Efficiency and Power Factor values, refer to separate document "PFH500F Series Evaluation Data".

5.2 C1 (1 μF); C4 (1 μF); C5 (2.2 μF) Film Capacitor or Class X Safety Capacitor

These capacitors are connected across the lines to reduce differential mode interference. Since the X cap is connected across the line and neutral, the current flowing through the cap can be high. When selecting X capacitor, be sure to check the allowable maximum ripple current rating of this capacitor.

TDK-Lambda Americas recommends the customers to verify the actual ripple current flowing through each X capacitor by measuring the current flow.

Connect C5 as close to the input terminals of PFH500 series power module [i.e. AC(L) and AC(N)] as possible.

Recommended Voltage Rating of X - Capacitors: 250 Vac or greater

5.3 L1 (6.3 mH); L2 (6.3 mH) Common Mode Choke

Add recommended common mode chokes to reduce EMI noise. When using multiple PFH500 series modules in parallel, it is important to provide EMI filtering (including X caps, Y caps, and common mode chokes) for each PFH500 module.

Note:

(1) TDK-Lambda Inductor was used during the testing process (TDK-Lambda Part #: ARA00499).

5.4 C2 (3300 pF); C3 (3300 pF) Ceramic Capacitor or Class Y Capacitor

Y-capacitors are used to protect against common mode noise. Be sure to consider leakage current requirement of your equipment or instrument when selecting these capacitors.

5.5 R1 (470 k Ω , 2 W); R3 (470 k Ω , 2 W); R4 (470 k Ω , 2 W)

Connect bleeder resistor, R1, across the AC input terminals and connect R3 and R4 in series across C9 and C10 as shown in Fig. 5-1.

5.6 C6 (470 pF); C7 (470 pF) Ceramic Capacitor or Class Y Capacitor

Add these Y capacitors as an EMI common-mode noise countermeasure. Be sure to consider leakage current of your equipment when selecting these capacitors.

Connect C6 as close as possible to AC(L) terminal. Connect C7 as close as possible to AC(N) terminal.

5.7 Electrolytic Bulk Capacitors: C9 (470 μ F); C10 (470 μ F)

Recommended Voltage Rating: 450 Vdc (105 °C rated capacitor)

Recommended Capacitance: 2 x 470 μ F

Notes:

1. Connecting capacitors with a higher capacitance value than mentioned could result in the PFH Series power module being damaged. Consult TDK-Lambda for higher bulk capacitance requirement.
2. When using the PFH power modules below -20 °C ambient temperature, both AC ripple of VBUS and output ripple voltage might be affected by ESR characteristics of the bulk capacitors. Therefore, be sure to verify characteristics by actual evaluation.
3. Bleeder resistors, R3 & R4 (470 k Ω / 2 W), are required to be connected across C9 or C10 to discharge the bulk capacitor voltage to a safe level after power off. Refer to Figure 5-1.
4. Do not connect any external load to the Bulk Capacitors or the module may be damaged.

Selection Method of External Bulk Capacitor for VBUS

C9 & C10 capacitor values are determined by intermediate bus voltage ripple, ripple current, and hold-up time. Select a capacitor value such that VBUS voltage ripple does not exceed 15 Vp-p.

Note: When the ambient temperature is $\leq -20\text{ }^{\circ}\text{C}$, the ripple voltage of C9 & C10 will increase due to ESR characteristics. Therefore, verify above characteristics by actual evaluation in the circuit.

For output hold-up time, refer to separate document "PFH500 Series Evaluation Data", and use appropriate capacitor. It is recommended that actual verification testing is performed.

For allowable capacitor ripple current value, refer to Fig. 5-2. Use of a capacitor with higher ripple current rating is highly recommended.

The bulk capacitor value affects the module's output hold-up time, dynamic line transient response, and dynamic load transient response characteristics

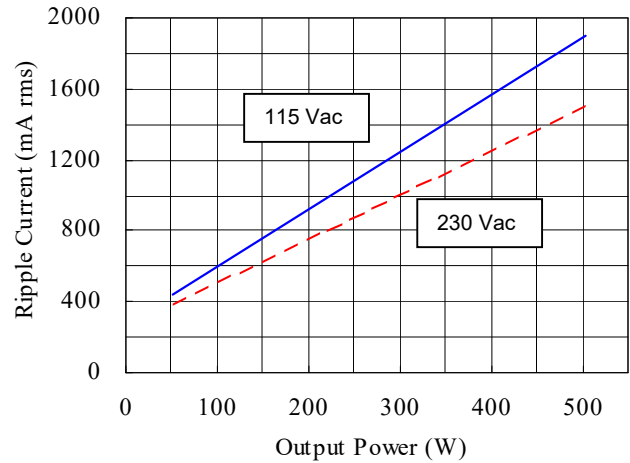

Fig. 5-2 Allowable Ripple Current Value

5.8 C11 (470 pF); C12 (470 pF)

Connect Y class ceramic or film capacitors as EMI noise countermeasure to reduce high frequency noise.

Capacitors with high voltage rating are typically required since high test voltages are often applied across these capacitors (between the output terminals and the module metal case) during Hipot testing. The metal case is connected to earth ground or equipment frame ground (application dependent). Connect C11 as close to Vo(+) terminal as possible, and C12 as close to Vo(-) terminal as possible.

5.9 C13 (0.1 μF, 50 V~100 V Ceramic Capacitor)

Add this output ceramic capacitor approximately 50 mm away from the PFH Series module output terminals to help reduce high frequency output noise.

5.10 C14 (40μF, 50 V~100 V or (4) 10 μF Ceramic capacitors in parallel)

Add this output ceramic capacitor approximately 50 mm away from the PFH Series module output terminals to help reduce the high frequency output ripple noise, and to improve the load transient response.

5.11 C15; C16 – Output Electrolytic Capacitors

Connect C15 and C16 approximately 50mm from the output terminals Vo(+) and Vo(-) of the PFH Series power module to stabilize the module operation. Note that the output noise ripple and the characteristics of the power module during input line turn off might be affected by the ESR and ESL values of the selected electrolytic capacitors. Also, note that output ripple voltage may vary depending on layout of the printed circuit board.

Changes in output voltage due to sudden load change or sudden input line voltage change can be reduced by increasing external output capacitance value.

Table 5-1 Minimum External Output Capacitance for C15, C16

Module Output Voltage	C15	C16
28 V	220 μ F, 50 V	220 μ F, 50 V
48 V	220 μ F, 100 V	220 μ F, 100 V
12 V	1500 μ F, 25 V	1500 μ F, 25 V

Note:

- (2) Panasonic capacitors (EEUFC##### Series) were used during the testing process.
- (3) Use low-impedance electrolytic capacitors with excellent temperature characteristics (Panasonic, Nippon Chemi-Con LXY Series or Nichicon PM Series or equivalent rated at least 105 °C).
- (4) For module operation at ambient temperature below -20 °C, the output ripple voltage will be affected by ESR characteristics of the electrolytic capacitors. Therefore, output capacitance and ESR must be maintained at lower operating temperatures.
- (5) Take note of the maximum allowable ripple current of the electrolytic capacitor used. Considering sudden load current changes, verify actual ripple current and make sure that allowable maximum ripple current of the external capacitor is not being exceeded.
- (6) If large output load steps are performed on the PFH module, it is recommended that the output capacitance be increased, but not to exceed the maximum capacitance value. Refer to the Data Sheet.

5.12 R2

By inserting a ceramic wire wound, thermal fused inrush resistor between the line filter and the input terminal, AC(L) as shown in Fig. 5-1, the inrush current can be limited to a pre-determined level. Proper inrush control is required during turn-on to avoid the external line fuse from being blown, the input circuit breaker from being tripped, the bulk capacitors and/or PFH Series module internal parts from being damaged, and to prevent oscillation between the input inductor and the bulk capacitors.

For 50 / 60 Hz operation, the maximum allowable resistance value is limited by the bulk capacitor bank charging time, and VBUS ramp-up time. The resistance value for R2 is between 20 Ω minimum and 30 Ω maximum. A 22 Ω / 1.6 W ceramic wire wound, thermal fused inrush resistor is typically recommended.

For 400 Hz operation, the maximum allowable resistance value is limited by the bulk capacitor bank charging time, and VBUS ramp-up time. The resistance value for R2 is between 9.4 Ω minimum and 10Ω maximum. Two 4.7 Ω / 5 W wire wound, fusible inrush resistor connected in series is typically recommended.

Note:

- (1) PFH500 series module will not operate if this external inrush resistor is not present.
- (2) For 50 / 60 Hz operations 22 Ω / 1.6 W is typically used (UCHIHASHI, Part#: A5MC-220J or TDK-Lambda Part#: AR00719)
- (3) For 400 Hz operations, two 4.7 Ω / 5 W resistors in series is typically used (TT ELECTRONICS, Part #: ULW5-4R7JT075)
- (4) For 400 Hz operations, R2 could be damaged if the applied input voltage exceeds maximum input voltage rating of 135 Vac.

Selection Method of External Resistor

- (1) Calculating Resistance Value for R2:

Resistance can be calculated by the formula below.

$$R2 = \frac{V_{in_pk}}{I_{rush}} (\Omega) \quad \text{(Formula 5-2)}$$

R2 : Minimum Resistance Value Required for External Thermal Resistor, R2
 Vin_pk : Maximum Input Voltage Peak Value = Maximum Input Voltage (rms) x $\sqrt{2}$
 Irush : Allowed Input Inrush Current Peak Value during Initial Power Switch ON

- (2) Required Surge Current Rating:

Sufficient surge current withstanding capability is required for external R2 thermal resistor. The required Surge Current Rating of R2 can be determined by I²t. (Current squared multiplied by time)

$$I^2t = \frac{C_b \times (V_{in_pk})^2}{2 \times R2} (A^2s) \quad \text{(Formula 5-3)}$$

I²t : Thermal Resistor current-squared multiplied by time rating
 Cb : Maximum Boost Output Bulk Capacitance
 Vin_pk : Maximum Input Voltage Peak Value = Input Voltage (rms) x $\sqrt{2}$
 R2 : Resistance Value for External Thermal Resistor, R2, Chosen

(3) R2 Maximum Value Limitation:

The maximum value of R2 is limited by R-C charging time. The higher the R2 value is, the lower the inrush current, but the longer the start-up time will be (see section 6-3 discussion). PFH Series modules do not have a second inrush event. When the ac line is switched on, the ac power source charges the bulk capacitor bank via the inrush resistor. Once the Boost converter output voltage (or bulk capacitor voltage) reaches about 70 V, the internal bias circuitry starts to work. After a short delay, the PFC controller starts to enable the PFC converter, which charges the bulk capacitor bank to a regulated voltage level, about 385 V. The value of the thermal resistor, R2, limits the PFC converter ramp – up time, especially when operating near low line.

5.13 RL Inrush Relay (12 V Coil, 10 A / 277 Vac; 16 A / 125 Vac)

An inrush relay is connected in parallel with R2 resistor. As soon as VBUS reaches the pre-set value (close to the peak of the maximum ac line voltage), the inrush control pin will energize the relay. This method mitigates or even eliminates the second inrush current event during the relay closing. **It is very important to make sure that the relay contacts are opened before applying AC power.** Otherwise, an inrush current surge will damage the PFH Series module.

The inrush relay chosen must have a maximum switching voltage ≥ 265 Vac. A relay with minimum of 10 A / 277 Vac, 16 A / 125 Vac rating, and 12 V / (15 to 20 mA) nominal coil operating voltage and current is recommended.

Note:

- (1) Panasonic relay (JVN1A-12V-F) was used during the testing process.

6 Explanation of Functions and Precautions

6.1 Input Voltage Range

PFH500F Series

Input AC voltage source should be within the ranged from 85 – 265 Vac (47-63 Hz). Connecting the PFH Series module to any power source outside of this specified range will prevent the module from starting.

PFH500F series power module is certified by various safety agencies with a certified label rating indicating: **100-240 Vac, 50-60 Hz, 8 A.**

PFH500A Series

Input AC voltage source must be within the range from 85 – 135 Vac (375-420 Hz). Connecting the PFH Series module to any power source outside of the recommended range may prevent the module from starting.

6.2 Output Grounding Scheme

Vo (-) and SGND are considered to be two separate grounds inside the PFH Series module. Vo (-) and SGND should not be connected together at any point.

Vo (-) is used as the return path for output load current and voltage, while SGND is used as the return path for logic signals (PMBus connection, Power Good, Trim, ON / OFF, and Aux Power).

6.3 Output Voltage Adjustment Range

The output voltage of the PFH Series module can be adjusted up and down by connecting a trim resistor between Trim pin and RS(+) pin or Vout(-) pin. Care must be taken to prevent the trim up voltage from exceeding 20% of the nominal voltage. Otherwise, it may activate the module's OVP protection function.

Output Voltage Adjustment Range: $\pm 20\%$ of the nominal output voltage setting

When trimming up the output voltage, the output current needs to be reduced to keep the maximum output power to 504 W or less. Operating beyond the specified ratings can cause permanent damage to the power module.

The trim-up and the trim-down connections using external resistor are shown in Fig. 6-2, and Figure 6-4. If the remote sensing feature is NOT used, the RS(+) pin needs to be connected to Vout(+) for local sensing. For details on Remote Sensing function, refer to Sec 6.8, Remote Sensing.

NOTE: Due to noisy environments, it is strongly recommended that an external 0.1 μF capacitor (Min) be placed from the Trim pin to SGND.

Output Voltage Adjustment using external Fixed Trim Resistor

Trim Up: With a trim resistor connected between the Trim pin and Vout (+) pin, the output voltage is adjusted up. To adjust the output voltage up a percentage of Vout (Δ%) from Vo,nom, the trim resistor (in kΩ) should be chosen according to the following equation:

$$R_{trim_up} = 5.11 \times \left(\frac{V_{0,nom} \times (100 + \Delta\%)}{V_{ref} \times \Delta\%} - \frac{100}{\Delta\%} - 2 \right) \quad \text{(Formula 5-4)}$$

$$\begin{aligned} \Delta\% &= 100 \times (V_{o,nom} - V_{desired}) / V_{o,nom} \\ V_{ref} &= 1.22 \text{ V} \end{aligned}$$

The trim-up resistor (Rt_up) values from +5% to +20%¹, can be found in Tables 6-1. The trim-up circuit connection is shown in Figure 6-2. Trim resistors should have +/-1% or better tolerance.

Table 6-1 External Trim-Up Resistor Value for						
	PFH500F-12-xxx		PFH500F-28-xxx		PFH500F-48-xxx ¹	
% Trim-Up of Vo_nom (Vo)	Trim-Up Resistance (Ω)	Calculated Vout (V)	Trim-Up Resistance (Ω)	Calculated Vout (V)	Trim-Up Resistance (Ω)	Calculated Vout (V)
+ 5%	1034 k	12.6 V	2391.4 k	29.4 V	4092 k	50.4 V
+ 10%	540.9 k	13.2 V	1250.3 k	30.8 V	2141 k	52.8 V
+ 15%	376.7 k	13.8 V	869.8 k	32.2 V		
+ 20%	294.6 k	14.4 V	679.6 k	33.6 V		

NOTE1: PFH500F-48-xxx can only trim up +10%

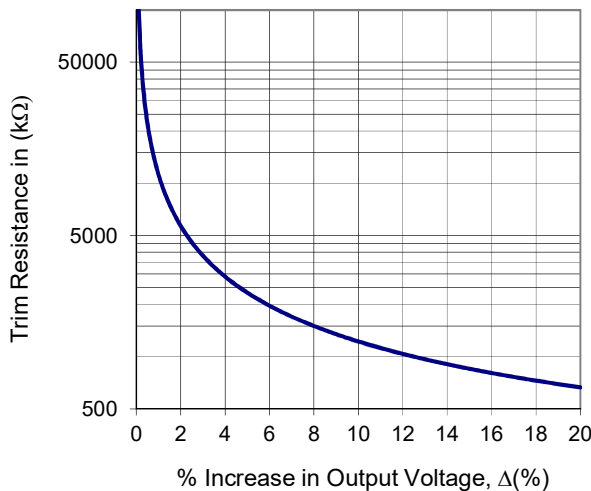

Fig. 6-1 Trim-Up Resistance vs. Percentage Voltage Trim-Up.

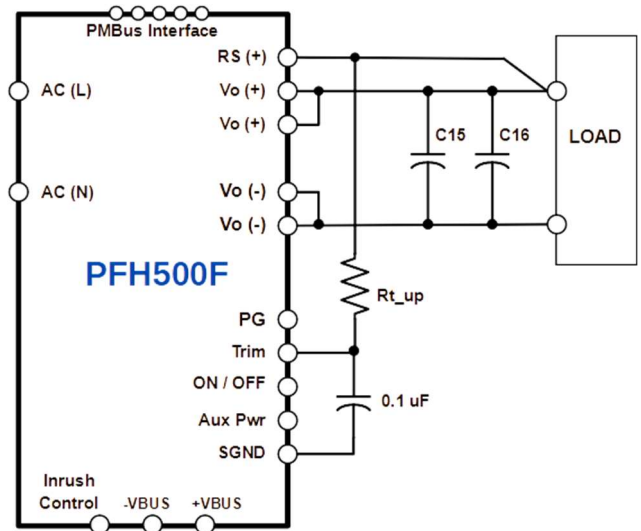

Fig. 6-2 External Trim-Up Circuit Connection.

Trim Down: With a resistor connected between the Trim pin and Vout (-) pin, the output voltage can be adjusted down. To adjust the output voltage down a percentage of Vout ($\Delta\%$) from Vo,nom, the trim resistor should be chosen according to the following equation (in k Ω).

$$R_{trim_down} = 5.11 \times \left(\frac{100}{\Delta\%} - 2 \right) \quad (\text{Formula 5-5})$$

The trim-down resistor (R_{t_down}) values for the trim-down voltage range from -5% to -20% can be found in Tables 6-2. The trim down connection diagram is shown in Figure 6-4.

Table 6-2 External Trim-Down Resistor Value				
		<i>PFH500F – 12 – xxx</i>	<i>PFH500F – 28 – xxx</i>	<i>PFH500F – 48 – xxx</i>
% Trim-Down of Vo_nom (Vo)	Trim-Down Resistance (Ω)	Calculated Vout (V)	Calculated Vout (V)	Calculated Vout (V)
- 5%	92.0 k	11.4 V	26.6 V	45.6 V
- 10%	40.9 k	10.8 V	25.2 V	43.2 V
- 15%	23.9 k	10.2 V	23.8 V	40.8 V
- 20%	15.3 k	9.6 V	22.4 V	38.4 V

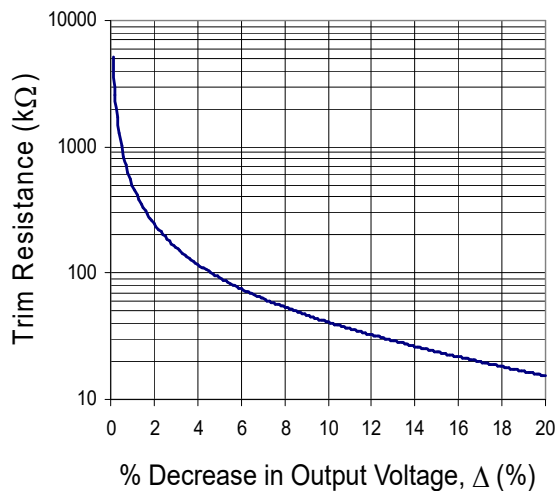

Fig. 6-3 Trim-Down Resistance vs. Percentage Voltage Trim-Down.

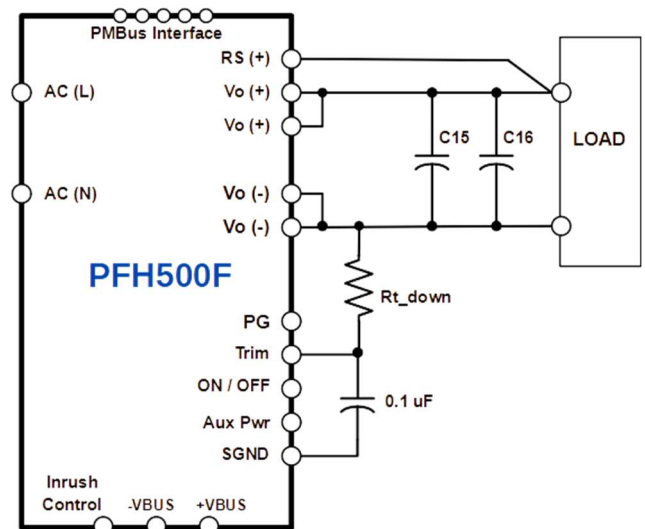

Fig. 6-4 External Trim-Down Circuit Connection.

6.4 Inrush Current

Input inrush or surge current changes with thermal fuse resistor (R2) value and the external boost converter bulk capacitance value (C9 and C10). It is recommended that actual evaluation testing be performed to confirm the inrush current value.

The inrush current peak values shown in the specification or data sheet are measured at nominal lines (115 Vac and 230 Vac), at 25 °C using the basic connection as shown in Figure 5-1.

The external line fuse should be chosen to handle the measured inrush peak current and based on the PFH product label. If used in conjunction with the line fuse, circuit breakers should be selected using the same criteria.

6.5 Output Over Voltage Protection (OVP)

PFH Series modules are equipped with an OVP protection function. The OVP function activates when output voltage is greater than the OVP trip-point. When the OVP triggers, the module output will shut down either with latch or auto-recovery depending upon the option code specified. The standard option for PFH Series modules is a latching over voltage protection.

When the OVP function activates, cut off the input ac line power. Afterwards, verify VBUS voltage has dropped below 10 V. Check for any abnormal conditions. Then, attempt to recover output voltage by cycling input voltage back on. In addition, the OVP latch can also be reset by turning the module off and then on using either the On/Off pin or via PMBus command.

The OVP set-point can be changed via PMBus. The OVP setting can only be lowered by via PMBus. The maximum allowed output voltage is limited by the pre-defined OVP voltage settings.

Care must be taken to avoid applying higher voltage externally to the output terminals of PFH Series module. Otherwise, it may cause permanent damage to the module.

6.6 Boost (or VBUS) Over Voltage and Under Voltage Protection (BOVP/BUVP)

PFH Series modules monitor the VBUS voltage to protect it from both over-voltage and under-voltage operation. If a module reaches these pre-defined protection levels, the module's output will shut down and VBUS will also shutdown. The module will attempt to auto-restart after the shutdown. The inhibiting time before restart depends on the value of the bulk caps and bleeder resistor values used.

6.7 Over Current Protection (OCP)

PFH Series modules are equipped with various OCP protection functions including input PFC over-current protection, DC-DC primary side peak cycle-by-cycle over-current protection, module over-load protection, and short circuit protection. In normal operating conditions as specified by the specification and derating curves, the OCP protection will not be activated.

The module OCP function triggers when the output current typically exceeds 105% to 140% of maximum rated DC output current in the specification. To reduce variation, the OCP set-point is temperature compensated, and is calibrated during the manufacturing test process.

When the PFH Series module is operated outside the specified input voltage range, the input OCP function may be activated to protect the module from drawing excessive input current to help guard against damage to the module.

The PFH Series OCP set-point is set to a fixed value, however it can be reduced via PMBus.

NOTE:

- (1.) Certain Electronic Loads may have excessive current overshoot which can cause the PFH overcurrent protection to engage.
- (2.) Continuous short circuit or overload conditions are not recommended and might result in power supply over-heating or damage.

6.8 Auto-Recovery Mode Option (Non-Latching)

Auto-Recovery is when the module will try to restart once the alarm condition has been removed and timer has cleared.

An alarm condition is either Over-Voltage, Under-Voltage, Over-Current, or Auxiliary Bias Power Over-Load.

- For modules with non-latching alarms, the module will enter a 2-second hiccup retry sequence once an alarm condition is detected.
- The module will try to re-start up to 6 times at 2-second hiccup interval.
- If the alarm condition remains after the module tries to re-start up to 6 times, then it will enter a 6-minute hiccup timer retry sequence.
- Once the module enters the 6-minute hiccup timer, it will stay there until the alarm condition is removed and timer has cleared.
- Once alarm condition and timer has cleared, module will restart and must operate for more than 7 minutes without any alarms. After the 7-minute counter has cleared, the module will revert to the standard 2-second hiccup timer when an alarm is detected. However, if an alarm occurs within the 7-minute window the module will initiate another 6-minute hiccup cycle.

6.9 Over Temperature Protection (OTP)

PFH Series modules are equipped with internal OTP protection function. There are multiple thermal sensors located in the hotspot of the PFH module. The digital controller reads back the temperature sensed and disables the operation based on the pre-set OTP settings. Refer to Sections 7.1 and 7.2 for the external thermal measurement location of the PFH module and for the module's safe operating range.

When any one of these sensors hit their temperature trigger point, the OTP protection will be activated, and the module will shut down. The module will re-start after the internal temperature drops below the re-start point, usually 20 °C below the trip point. Non-latching, auto-restart OTP protection is a standard feature for PFH modules.

Note: When a module recovers from an OTP fault, the module might trip OCP during the start-up and cause a long hiccup delay (6 Minutes). Therefore it is recommend to reduce the module's load current to 80% of its output current rating prior to OTP recovery.

6.10 Remote Sensing

PFH Series modules have one remote sensing terminal, RS(+), to compensate for the line drop from the output terminals to the output load. When the remote sensing is not required, i.e. using local sensing, be sure to short RS(+) pin to the Vout(+) pins. Note, the output line drop (the voltage drop due to long cable impedance) and voltage compensation range must fall within the typical (50 mV) output remote sense range. At any conditions, the maximum output power of PFH module should not be exceeded.

When using the remote sensing feature, do adequate evaluation to make sure the module does not have excessive noise or oscillation at the load terminals. Should a noise filter inductor be inserted between Vo(+) pin(s) and the load terminal, the RS(+) sense must be connected on the module's side of the inductor. Some precaution in the layout may be needed. Contact TDK-Lambda Technical Support for assistance if needed.

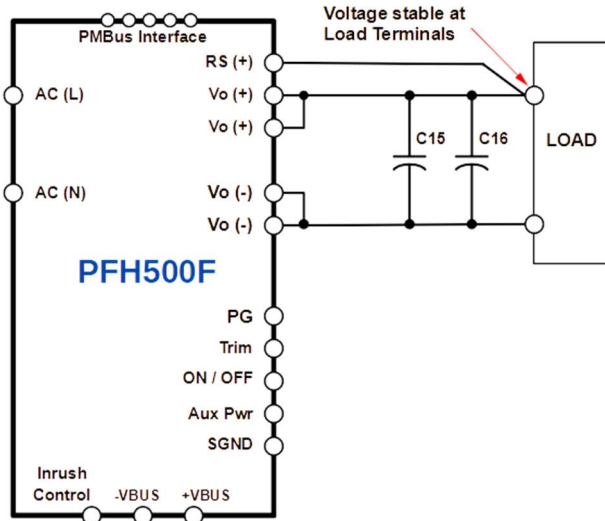

Fig. 6-5 Remote Sensing is USED.

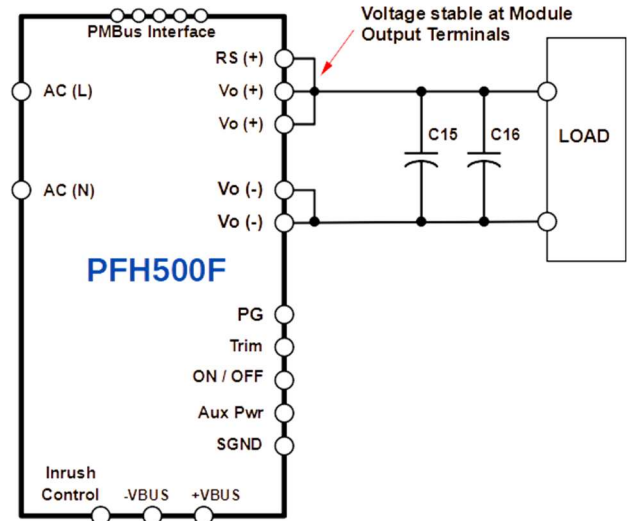

Fig. 6-6 Remote Sensing is NOT USED (Local Sensing).

6.11 ON-OFF Control

PFH Series modules have an ON-OFF control pin, which is used to enable (turn on) or disable (turn off) the module. When this pin is low, the PFH module is enabled. Internally, this pin is connected to a 10 k Ω pull-up resistor that is in series with 3.3 V source. Due to noisy environments, it is strongly recommended that an external 0.1 μ F capacitor (Min) be placed from the ON-OFF pin to SGND.

Maximum sink current of ON-OFF pin	: 300 μ A
Maximum low voltage for ON-OFF pin	: 1 V
Maximum high voltage of ON-OFF pin	: 3.3 V

ON-OFF pin references to SGND.

The digital controller inside the module will remember the ON-OFF control sequence. If the module is enabled by ON-OFF pin, then it must be turned off by ON-OFF pin. Trying to turn off the module by PMBus will be ignored. If the module is enabled by PMBus control, then it must be turned Off through PMBus control, the ON-OFF pin control function will be ignored.

Rapid toggling of the enable pin is not recommended. If the PFH module is turned off and back on too quickly there may be a short delay time before the unit will respond.

Various ON-OFF pin connection schemes are shown below:

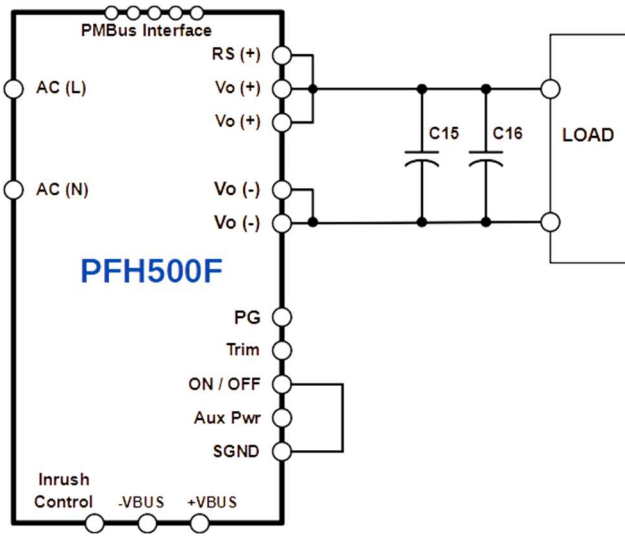

Fig. 6-7a ON-OFF Pin Tied Active.

NOTE: Module is always On

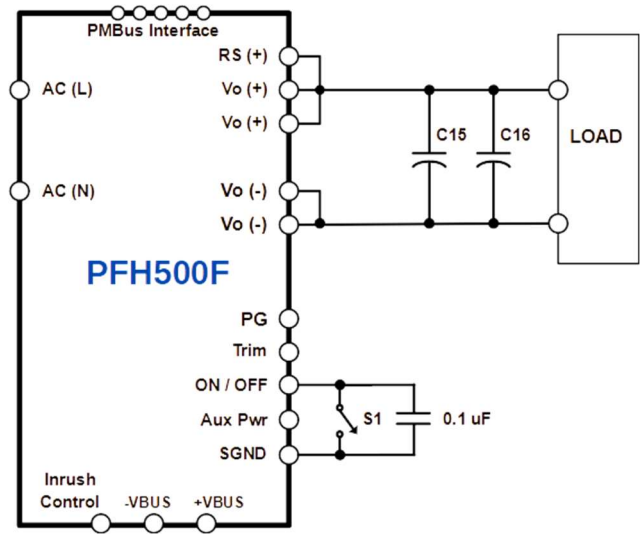

Fig. 6-7b ON-OFF Control Using Switch.

NOTE: S1 should be located next to the module

6.12 Power Good Signal (PGood)

PFH Series modules have an Open-Drain Power Good pin. The PGood pin can be used to either turn on or off load(s), or to communicate with external controllers and signal the system regarding the status of PFH module. An external pull-up resistor is required to limit sink current.

When the output voltage of PFH module is within the specified output voltage regulation band, the Power Good signal is activated. An active “Low level” indicates Power Good.

Maximum sink current of Power Good pin	: 150 mA
Maximum voltage of Power Good Pin	: 50 V
V _{OUT_LOW} (Max)	: 1 V @ 150 mA

Some filtering (hardware and/or software) of the Power Good pin may be required for applications with large noise levels.

It is recommended to use the Power Good signal to ensure the PFH output has reached regulation before enabling downstream loads.

6.13 Auxiliary Bias Power

PFH Series modules have an Auxiliary Bias Supply pin, referenced to SGND. It is capable of providing a loosely regulated 12 V bias (10 – 14 V, with 200 mA maximum current). The auxiliary bias supply output is enabled whenever the PFH module is provided a source voltage within its rated input voltage range. The auxiliary bias supply is internally protected against over loading. Severe over loading may cause the auxiliary bias and the PFH module to shut down. The auxiliary bias supply voltage and PFH module will auto-recover after the overload condition is removed. Refer to Section 6.8, Auto-Recovery Mode Option.

6.14 OPTIONAL Droop Load Share (Parallel Operation)

Droop load sharing scheme is available. The droop load share scheme senses the module's output load current, and then intentionally lowers the output voltage reference, which then in turns reduces the regulated output voltage as shown in Figure 6-8b.

Use of OR-ing diodes (Schottky diodes or Or-ing FETs) with same forward voltage drops and same temperature rise characteristics is required. The use of the OR-ing diodes is to prevent any negative current from flowing back into the PFH module(s).

In steady state and near ideal sharing, each PFH Series module will provide close to 50% of the total load current. Figure 6-8c depicts two PFH units running at 18 A load, and then one of the units is turned off.

The load share accuracy is a function of the module's initial output voltage setting accuracy, load current sensing accuracy, output wiring impedance differences, and the forward voltage drop difference of the external OR-ing diodes (or OR-ing FETs). Dual-Packaged Schottky diodes with the same forward voltage drop and temperature characteristics will help improve the load share accuracy.

When using droop current sharing, the RS (+) needs to be connected for local sense mode, i.e. to Vo (+) pins.

Since PFH Series modules feature hiccup OCP protection scheme, in a multiple module parallel system, start-up load current must be the same or less than one PFH module's maximum rated current to avoid start-up problems.

It is recommended that the load is enabled after the output voltage has been established (e.g. use the Power Good feature to enable the load). Derate load by 10% when operating in parallel.

NOTE: The Auxiliary Bias Power cannot be connected in parallel.

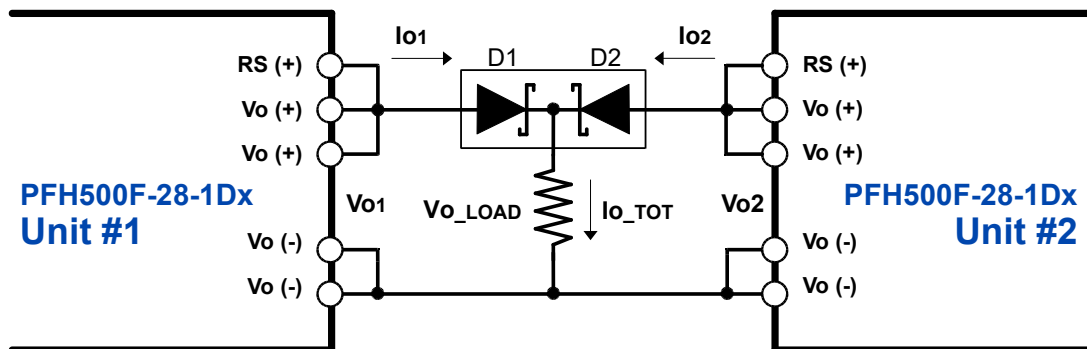

Fig. 6-8a Droop Load Share Configuration (with OR-ing Diodes)

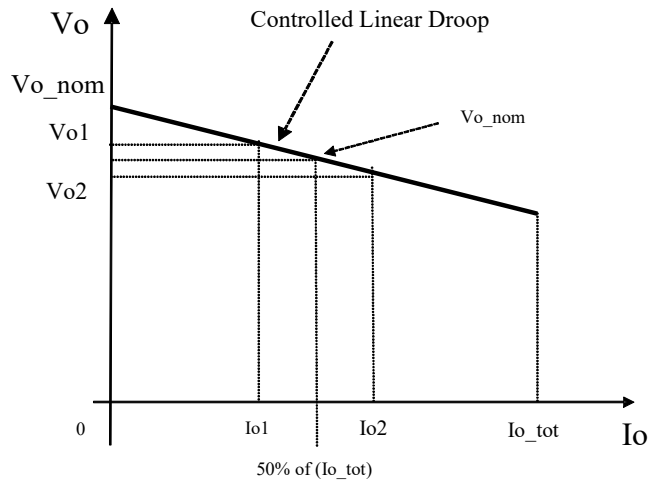

Fig. 6-8b Two PFH Modules in Droop Load Share Mode (with OR-ing Diodes).

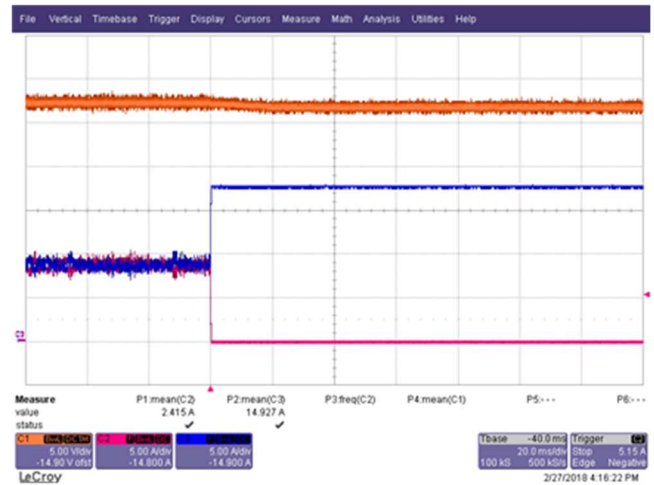

Fig. 6-8c Two PFH Modules running 18 A Load and then one (1) PFH module turned Off.

6.15 PMBus Communication

The PFH Series module supports PMBus. This allows the host computer to communicate with the PFH module controller to either read out, command, or set the module(s) operating parameters.

PFH Series module operating status and telemetry can be monitored over the PMBus. PMBus can also be used to modify some of the operation parameters and/or limit settings, etc. For details, please refer to TDK-Lambda "PFH PMBus Specification and Application Note".

NOTE: If the PMBus feature set is utilized then an external 2200 pF capacitor should be placed from the PMBus_Add1 pin to SGND and PMBus_Add2 pin to SGND.

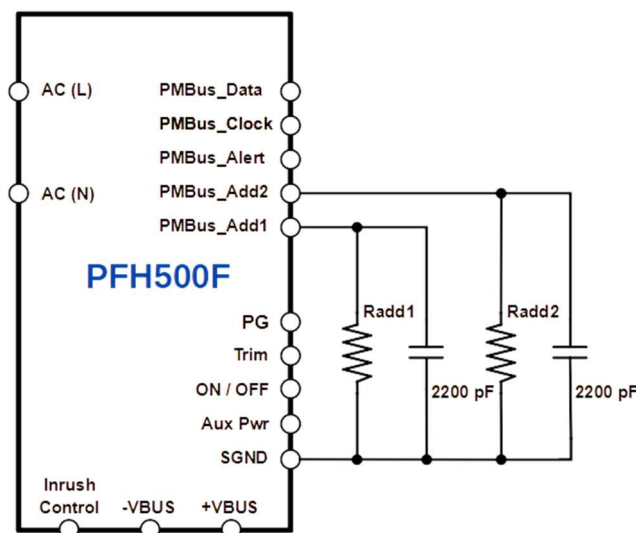

Fig 6-9 PMBus Addressing Configuration

6.16 Ripple and Noise

The output ripple and noise is measured in accordance with industry practices.

The output noise measurement connection can be found in the diagram shown in Figure 6-9 below.

A 0.1 μF ceramic capacitor, C13, and four (4) 10 μF ceramic capacitors, C14, are connected across the PFH module's output bus at a location 50 mm from the module output terminals. A 20 MHz bandwidth oscilloscope is recommended to be used to measure peak-peak and RMS values.

Note that the measured high frequency noise spikes may vary depending on the wiring pattern of the printed circuit board, and the contact impedance of the scope coaxial cable connection.

In general, the module's output ripple spikes can be reduced by increasing external ceramic capacitor quantity and value.

NOTE: Noise is an RF frequency measurement that requires RF measurement techniques. Do not use flying ground leads on oscilloscope probes. An RF connector is required for accurate measurements.

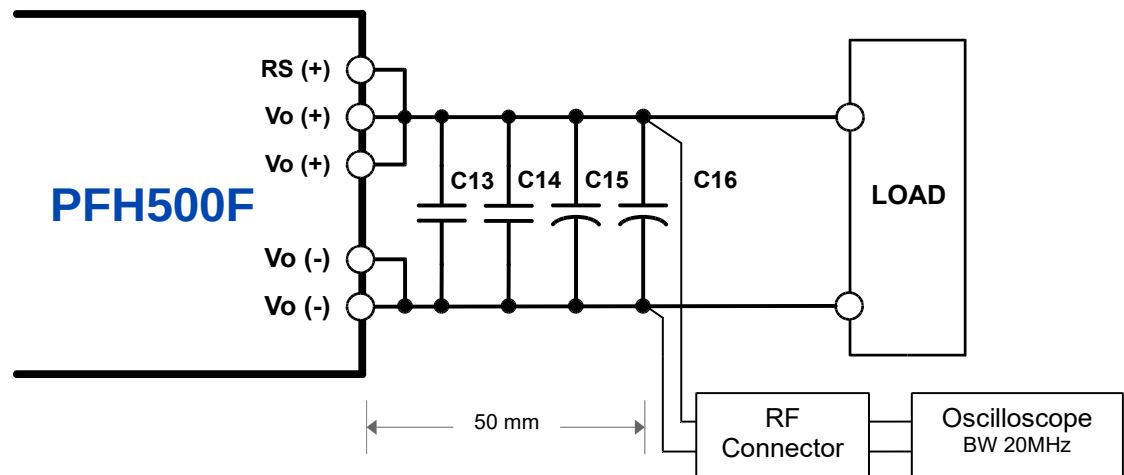

Fig 6-10 Output Noise or Ripple (including Spike Noise) Measurement Method.

6.17 Series Operation

To increase the output voltage of a PFH Series module, it is possible to connect two or more PFH500 Series modules in series. For two modules connected in series configuration, the connection diagrams are shown in Figure 6-10a and Figure 6-10b. The output voltage from each module can be set (or trimmed) to different levels to form various combination of the total output voltages. The RS(+) pin needs to be connected at local sense mode, i.e. to Vo(+) pin(s). Care must be taken when using the ON-OFF feature in this configuration. Optocouplers or other isolated devices are needed. Contact TDK-Lambda Customer Support for assistance.

$$V_{out_tot} = V_{out1} + V_{out2}$$

(Formula 5-6)

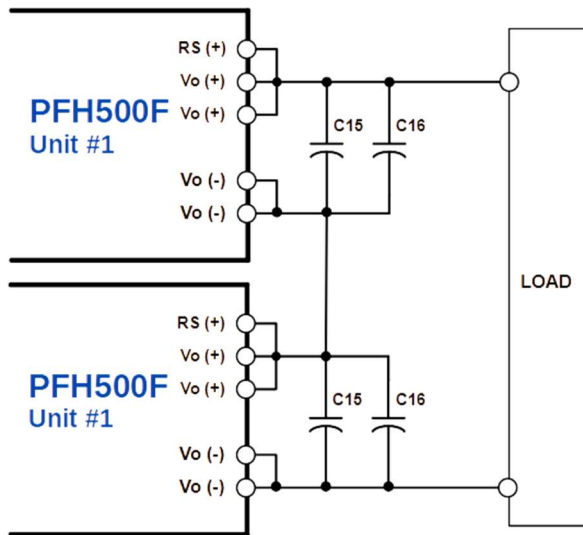

Fig. 6-11a Series Operation #1 (Higher Output Voltage).

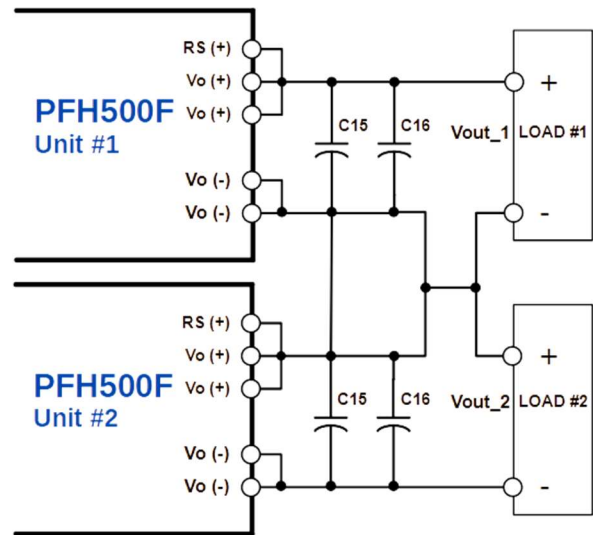

Fig. 6-11b Series Connection #2 (Different Load with Different Output Voltage).

6.18 Isolation Resistance

The isolation resistance between the PFH Output and the module's case typically will be 100 MΩ with 500 Vdc applied.

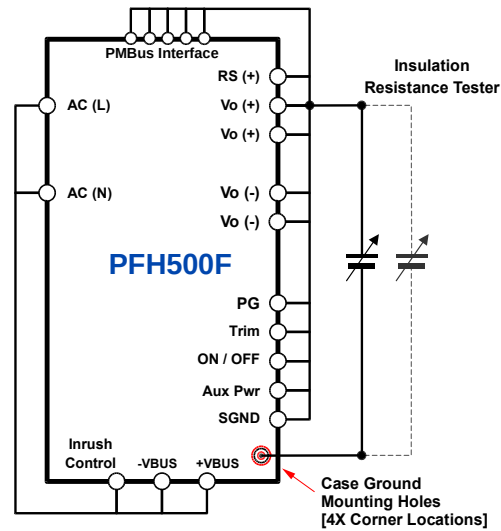

Fig 6-12 Isolation Resistance Test Method

6.19 Withstand Voltage Test (Hipot Test)

PFH Series modules are designed to withstand 2.5 kVac between input and module case, 3.0 kVac (reinforced voltage) between input and output, and 1.5 kVdc between output and case, each for 1-minute dwell. When testing withstand voltage (or Hipot test), set the leakage current limit of the withstand voltage tester (or Hipot tester) to 20 mA.

Be sure to apply only DC Hipot test voltages between output and case. AC test voltages between output and case may damage PFH modules.

The applied voltage must be gradually ramped from zero-volts to preset testing level, and then gradually decreased back to zero-volts. The ramp rate must not exceed 300 Vrms/sec and the dwell time should be 1 sec in mass production or 60 seconds during the safety qualification test. Connect each terminal of PFH module according to the circuit diagrams as shown in Figure 6-12a, Figure 6-12b, and Figure 6-12c.

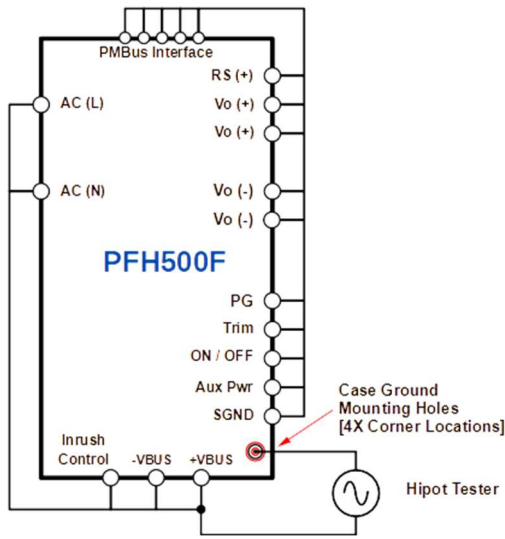

Fig. 6-13a Input to Case Hipot Test Method.

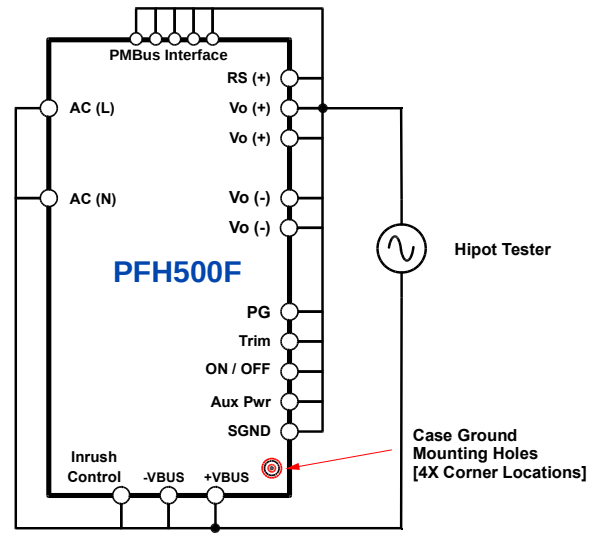

Fig. 6-13b Input to Output Hipot Test Method.

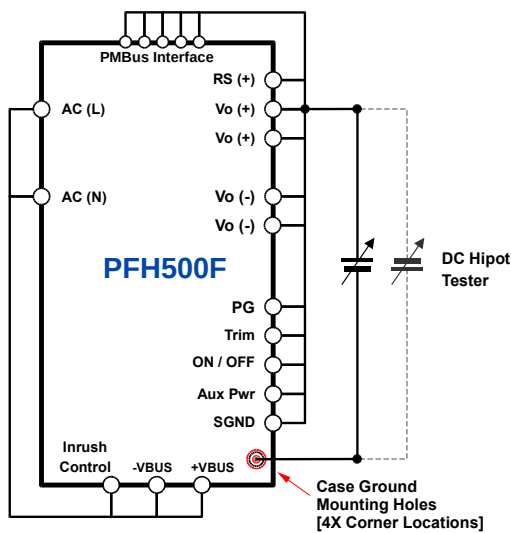

Fig. 6-13c Output to Case Hipot Test Method.

Withstand Voltage Testing with External Supporting Circuitry

The aforementioned Withstand Voltage Testing (or Hipot testing) only applies to PFH Series power module as a stand-alone unit. If the Withstand Voltage Testing is to be performed in a system level with the supporting circuitry such as shown in Fig. 5-1, care must be taken to check and verify the voltage rating of the selected external capacitors (and/or MOVs, and spark gaps for line surge protection) between the Input terminals and Case, and Output terminals and Case.

- | | |
|--|------------------|
| Capacitor: Input terminals to Case (or Frame GND) | : C2, C3, C6, C7 |
| Capacitor: Output terminals to Case (or Frame GND) | : C11, C12 |

7 Thermal Considerations and Mounting Method

7.1 Thermal Consideration

The PFH Series module is designed for both convection and conduction cooling applications.

This product can be mounted in any orientation, but for forced convection applications, be sure to provide adequate airflow around the power supply to avoid heat accumulation. Consider layout of surrounding components and orient the PFH such that air flow across module is optimized.

It is recommended that this product operate when case temperature is maintained at or below the derating curves as shown in Figure 7-2. The maximum case temperature should be 100 °C or less regardless of the input operating line voltage and/or frequency. For any technical issues related to thermal derating, thermal test set-up, mounting, the heat sink attachment, and use of the thermal interface material, please contact TDK-Lambda Americas for technical support.

Case temperature thermal measurement location is shown in Fig. 7-1.

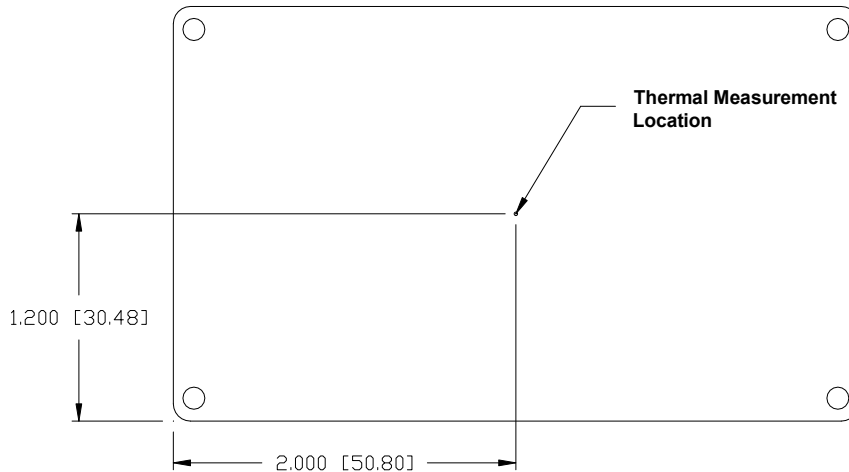

Fig. 7-1 Baseplate Temperature Measuring Point.

To achieve a more rugged physical design and minimize common mode noise, the PFH Series module is constructed without an Insulated Metal Substrate (IMS) board. Instead the PFH construction comprises of a multi-layer, heavy Cu PCB enclosed within a 5-sided insulated case.

7.2 Thermal Test Setup

The thermal derating curves in Section 7.3 are based upon measurements obtained in a test setup that simulates typical conduction cooled applications. The PFH module is isolated from the external ambient air so there is no forced convection. A large aluminum heatsink is attached to the PFH metal case to maintain its case temperature. The power module is mounted onto an 8-layer 2oz copper PCB with pins connected to power planes on multiple layers. The PFH internal construction consists of a single multilayer PCB installed inside a five-sided insulated metal case with thick copper power pins to connect the module to the mounting PCB. Heat is transferred from the module pins into the mounting board. If this heat transfer mechanism is reduced, lower maximum case operating temperatures can result. Contact TDK-Lambda technical support for additional assistance with thermal management of PFH power modules.

7.3 Output Current / Case Temperature Thermal Derating

PFH500F module is derated according to Figure 7-2. Derating varies based on AC input voltage and desired case temperature/output current.

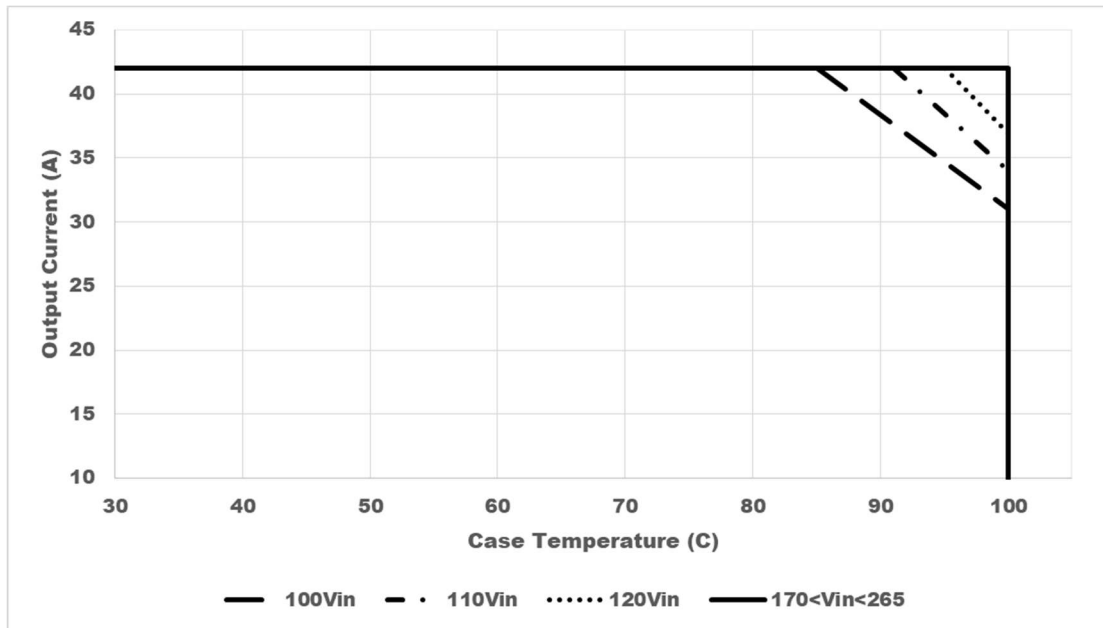

Fig. 7-2a PFH500F-12-xxx Derating Curves.

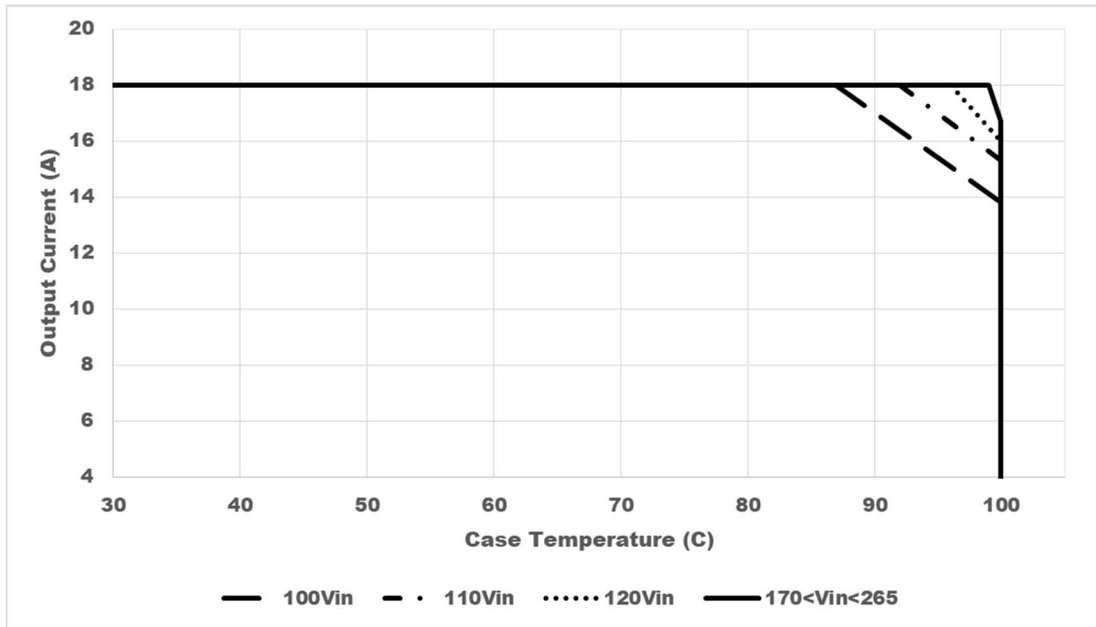

Fig. 7-2b PFH500F-28-xxx Derating Curves.

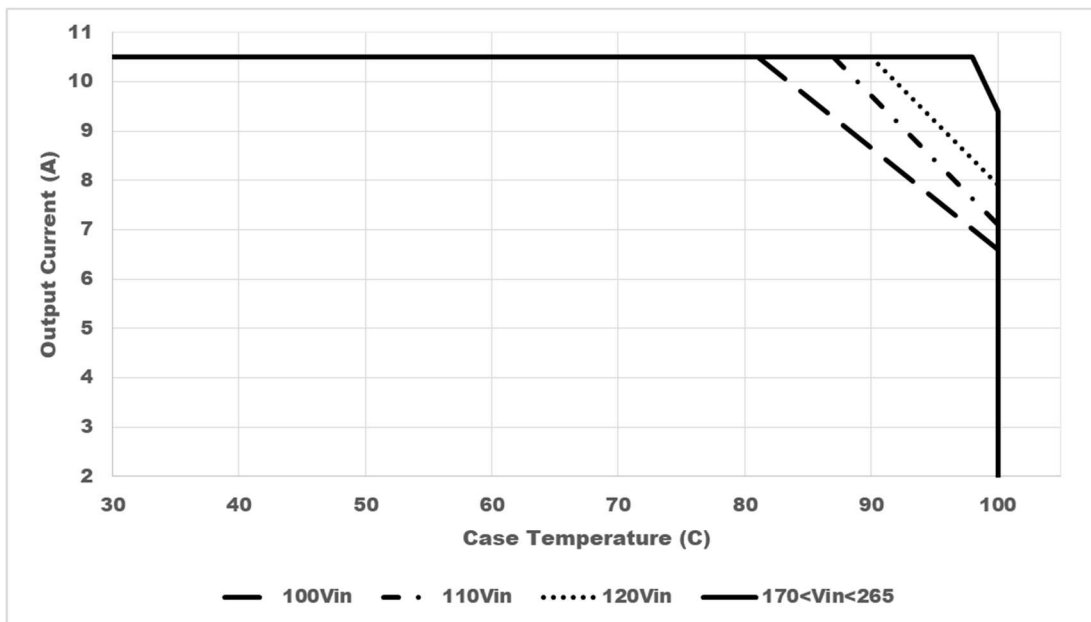

Fig. 7-2c PFH500F-48-xxx Derating Curves.

7.4 Recommended Soldering Condition

Recommended soldering temperature is as follows:

Soldering Dip : 260 ± 5 °C, within 10 seconds
Preheat : 130 °C

7.5 Recommended Washing Condition

After soldering, the following washing condition is recommended.

For other washing conditions, consult TDK-Lambda Americas Technical Support.

- (1) Recommended washing solution
IPA (Isopropyl Alcohol)
- (2) Washing method
In order to avoid penetration inside the power module, washing should be done with brush. Then, dry up thoroughly after washing.

8 Troubleshooting Guide

To ensure proper operation of the PFH module, the recommended test setup, required external components, connections and specified test limits as described in this Instruction Manual should always be followed.

In the unlikely event that the PFH module encounters the abnormal performance behavior described below, the troubleshooting guide maybe able to help rule out any external factors outside of the module that may be causing the abnormality.

- (1) No output voltage
 - a. Is specified input voltage applied to the module's input pins (Pin #1 & Pin#2)?
 - b. Is the Remote ON/OFF (Pin #5) pulled low or tied to SGND (Pin #11)?
 - c. During output voltage adjustment, is the correct fixed resistor used?
 - d. Is the power module attempting to re-start (hiccup mode, Refer to section 6.6)?
 - e. Is the output load within the range of the module under test?
 - f. Is the case temperature (Refer to section 7) within the specified operating temperature range of this module?
 - g. Does the output load current overshoot and exceed the modules current rating at startup?
 - h. Disconnect AC input voltage, wait 60 seconds, re-apply AC Input Voltage, then enable module?
- (2) Output voltage is too high
 - a. Is the remote sensing terminal RS(+) correctly connected?
 - b. Is the measurement done at the sensing points?
 - c. During output voltage adjustment, is the fixed resistor used correct?
- (3) Output voltage is too low
 - a. Is the remote sensing terminal RS(+) correctly connected?
 - b. Is the measurement done at the sensing points?
 - c. During output voltage adjustment, is the fixed resistor used correct?
 - d. Is there an abnormality with the output load?
- (4) Load regulation or line regulation is out of specification
 - a. Is specified input voltage applied?
 - b. Are the input or output terminals firmly connected?
 - c. Is the measurement done at the sensing points?
 - d. Are the Input and Output cables properly sized?
 - e. Is the output capacitance within the range per Table 5-1?
- (5) Large output ripple
 - a. Is the measurement done according to methods described in the Instruction Manual (Section 6.14)?
 - b. Is the recommended ceramic capacitance used?
 - c. Is the measuring probe contact resistance too large (dirty or greasy)?

9 Warranty Period

Standard warranty is 3 years or whatever is specified on the purchasing agreement.

The following cases are not covered by warranty:

- (1) Improper use like dropping products, applying excessive shock, spilling fluids on the module, etc.
- (2) Operating the PFH Series module outside the specification or not following this Instruction Manual.
- (3) Defects resulting from natural disaster (fire, flood, earthquake, tornado, hurricane, etc...).
- (4) Unauthorized modifications or repair by the buyers/customers.

10 Appendix

10.1 EMI Conducted Emissions CISPR 32:2015 Class B Recommended Values

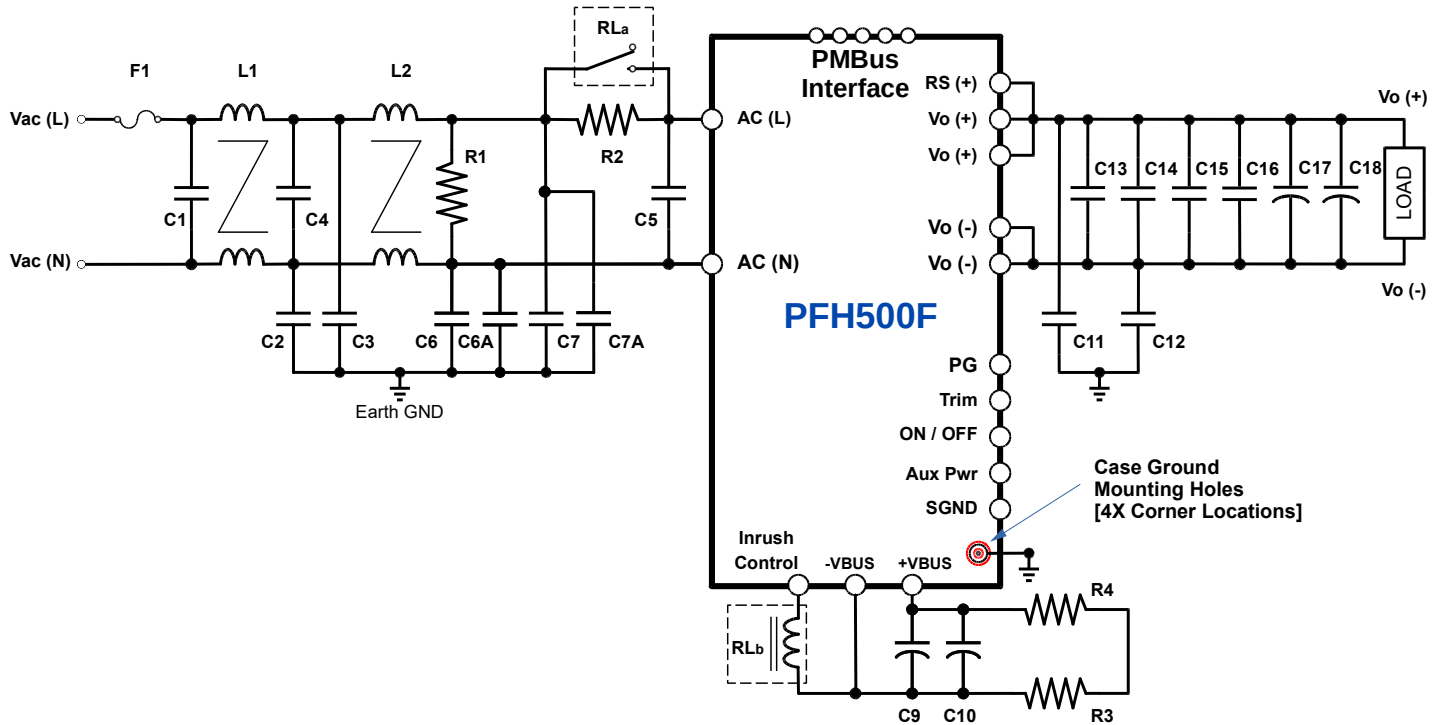

Figure 10.1 PFH500F-12-xxx-R

C1, C4	1 μ F Film Capacitor	C13, C14, C15, C16	10 μ F Ceramic Capacitor
C2, C3	3300 pF Ceramic Capacitor	C17, C18	1500 μ F Electrolytic Capacitor
C5	2.2 μ F Film Capacitor	F1	10 A, 250 V, Fast Blow
C6, C7	330 pF Ceramic Capacitor	L1, L2	6.3 mH
C6A, C7A	68 pF Ceramic Capacitor	R1, R3, R4	470 k Ω , 2 W
C9, C10	470 μ F Electrolytic Capacitor	R2	22 ohms
C11, C12	470 pF Ceramic Capacitor	RL	1 Form A relay with 10 A, 277 Vac, power rating: 12 Vdc, 16.7 mA, 200 mW, High Sensitivity

NOTE:

- (1) For EMI Conduction EMI Emission testing (Class A & B) Fair-Rite 31 material was used on the Input and Output cables.
- (2) Input cable 3-turns and Output cable 4-turns.

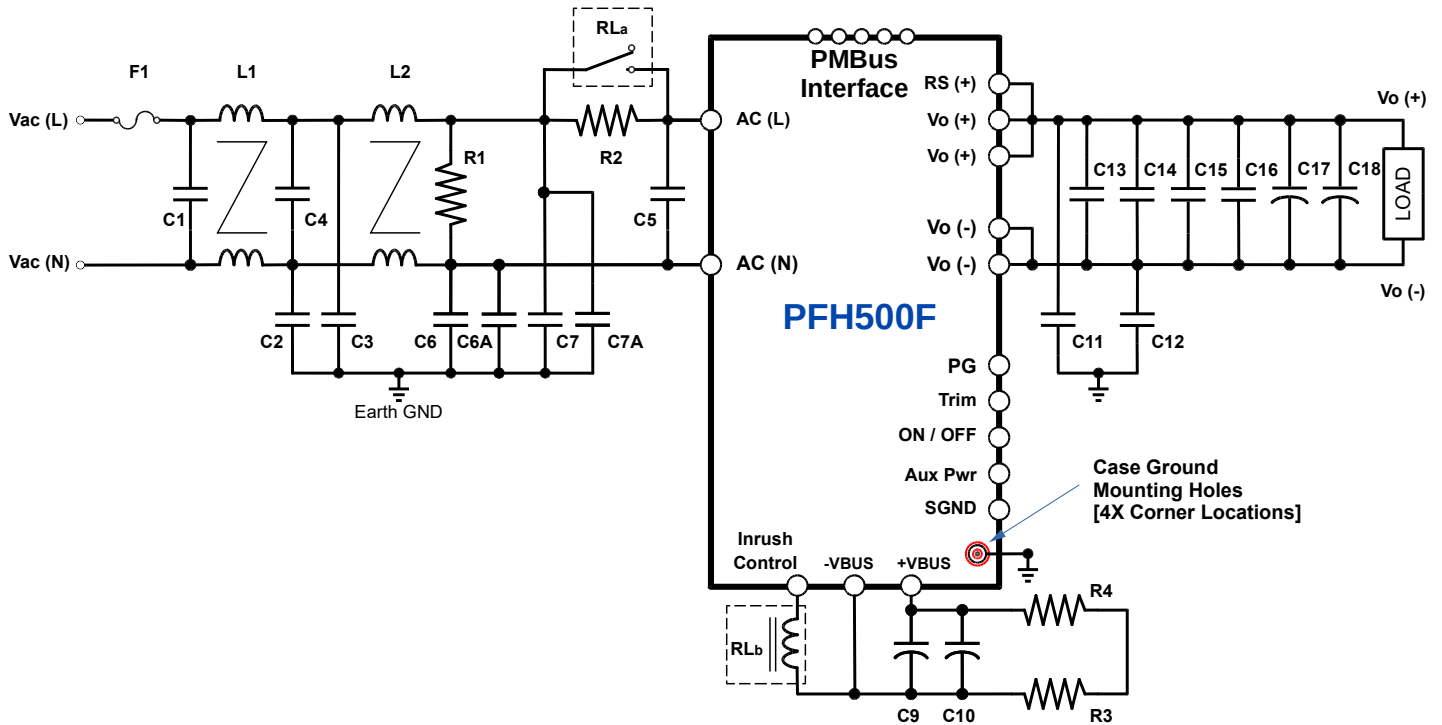

Figure 10.2 PFH500F-28-xxx-R

C1, C4	1 μ F Film Capacitor	C17, C18	470 μ F Electrolytic Capacitor
C2, C3	3300 pF Ceramic Capacitor	F1	10 A, 250 V, Fast Blow
C5	2.2 μ F Film Capacitor	L1, L2	6.3 mH
C6, C7, C11, C12	470 pF Ceramic Capacitor	R1, R3, R4	470 k Ω , 2 W
C9, C10	470 μ F Electrolytic Capacitor	R2	22 ohms
C13, C14, C15, C16	10 μ F Ceramic Capacitor	RL	1 Form A relay with 10 A, 277 Vac, power rating: 12 Vdc, 16.7 mA, 200 mW, High Sensitivity

NOTE:

- (1) For EMI Conduction EMI Emission testing (Class A & B) Fair-Rite 31 material was used on the Input and Output cables.
- (2) Input cable 3-turns and Output cable 4-turns.

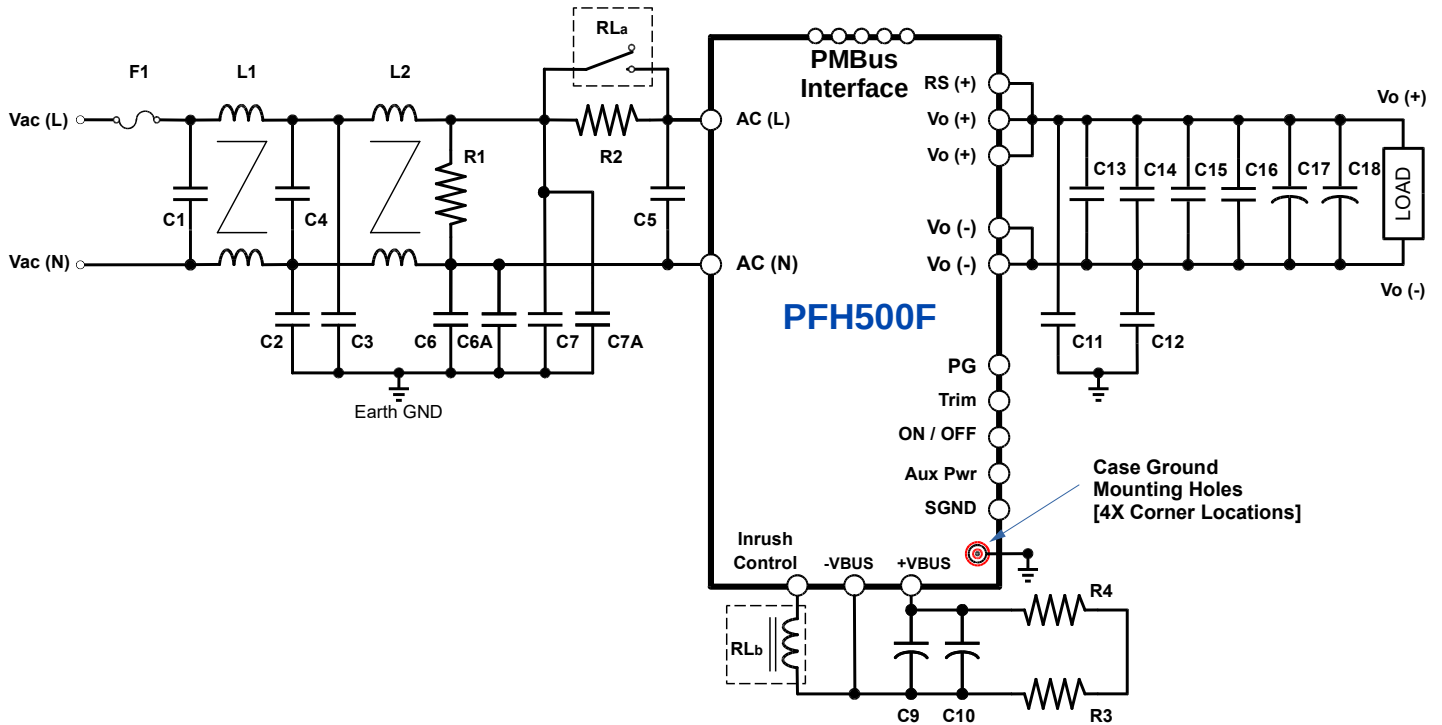

Figure 10.3 PFH500F-48-xxx-R

C1, C4	1 μ F Film Capacitor	C13, C14, C15, C16	10 μ F Ceramic Capacitor
C2, C3	3300 pF Ceramic Capacitor	C17, C18	470 μ F Electrolytic Capacitor
C5	2.2 μ F Film Capacitor	F1	10 A, 250 V, Fast Blow
C6, C7	470 pF Ceramic Capacitor	L1, L2	6.3 mH
C6A, C7A	330 pF Ceramic Capacitor	R1, R3, R4	470 k Ω , 2 W
C9, C10	470 μ F Electrolytic Capacitor	R2	22 ohms
C11, C12	2200 pF Ceramic Capacitor	RL	1 Form A relay with 10 A, 277 Vac, power rating: 12VDC, 16.7 mA, 200 mW, High Sensitivity

NOTE:

- (1) For EMI Conduction EMI Emission testing (Class A & B) Fair-Rite 31 material was used on the Input and Output cables.
- (2) Input cable 3-turns and Output cable 4-turns.

11 Document History

Revision:	Date:	Description:
3.1	6/18/2021	Add Section 11, Document History Table
		Section 6.10, added sentence to the end of the section, regarding Power Good sequence start-up.
		Case pin has been removed from all Figures
	7/22/2021	Added Section 6.2, Output Grounding Scheme
		Added TDK-Lambda Part # to Sections 5.3 and 5.12 Refreshed all Figures
3.2	2/22/22	Revised Section 6.7, Over Current Protection (OCP) Added Section 6.8, Auto-Recovery Mode Option (Non-Latching)
3.3	11/22/22	Updated Section 7.2
3.4	5/5/23	Updated Section 6.13, Updated pin's description.
		Updated Section 6.11, ON-OFF pin, is now referenced to SGND. Also updated toggling of the ON-OFF pin.
		Updated Section 6.8, Added Auxiliary Bias Power Overload as an alarm.
		Updated Section 4, Updated timing chart. Updated Section 10.1, Added Fair-Rite 31 material to note.

Information furnished by TDK-Lambda is believed to be accurate and reliable. However, TDK-Lambda assumes no responsibility for its use, nor for any infringement of patents or other rights of third parties, which may result from its use. No license is granted by implication or otherwise under any patent or patent rights of TDK-Lambda. TDK components are not designed to be used in applications, such as life support systems, wherein failure or malfunction could result in injury or death. All sales are subject to TDK-Lambda's Terms and Conditions of Sale, which are available upon request. Specifications are subject to change without notice.



TDK-Lambda France SAS

Tel: +33 1 60 12 71 65
 ttf.fr.powersolutions@tdk.com
 www.emea.lambda.tdk.com/fr



Italy Sales Office

Tel: +39 02 61 29 38 63
 ttf.it.powersolutions@tdk.com
 www.emea.lambda.tdk.com/it



Netherlands

tfn.nl.powersolutions@tdk.com
 www.emea.lambda.tdk.com/nl



TDK-Lambda Germany GmbH

Tel: +49 7841 666 0
 tlq.powersolutions@tdk.com
 www.emea.lambda.tdk.com/de



Austria Sales Office

Tel: +43 2256 655 84
 tlq.at.powersolutions@tdk.com
 www.emea.lambda.tdk.com/at



Switzerland Sales Office

Tel: +41 44 850 53 53
 tlq.ch.powersolutions@tdk.com
 www.emea.lambda.tdk.com/ch



Nordic Sales Office

Tel: +45 8853 8086
 tlq.dk.powersolutions@tdk.com
 www.emea.lambda.tdk.com/dk



TDK-Lambda UK Ltd.

Tel: +44 (0) 12 71 85 66 66
 tlu.powersolutions@tdk.com
 www.emea.lambda.tdk.com/uk



TDK-Lambda Ltd.

Tel: +9 723 902 4333
 tli.powersolutions@tdk.com
 www.emea.lambda.tdk.com/il-en



TDK-Lambda Americas

Tel: +1 800-LAMBDA-4 or 1-800-526-2324
 tla.powersolutions@tdk.com
 www.us.lambda.tdk.com



TDK Electronics do Brasil Ltda

Tel: +55 11 3289-9599
 sales.br@tdk-electronics.tdk.com
 www.tdk-electronics.tdk.com/en



TDK-Lambda Corporation

Tel: +81-3-6778-1113
 www.jp.lambda.tdk.com



TDK-Lambda (China) Electronics Co. Ltd.

Tel: +86 21 6485-0777
 tlc.powersolutions@tdk.com
 www.lambda.tdk.com.cn



TDK-Lambda Singapore Pte Ltd.

Tel: +65 6251 7211
 tfs.marketing@tdk.com
 www.sg.lambda.tdk.com



TDK India Private Limited, Power Supply Division

Tel: +91 80 4039-0660
 mathew.philip@tdk.com
 www.sg.lambda.tdk.com

