

ZWS15B/A

SPECIFICATIONS

CA791-01-01/A-A

ITEMS		MODEL	ZWS15B -3/A	ZWS15B -5/A	ZWS15B -12/A	ZWS15B -15/A	ZWS15B -24/A	
1	Nominal Output Voltage	V	3.3	5	12	15	24	
2	Maximum Output Current	A	3.0	3.0	1.3	1.0	0.7	
3	Maximum Output Power	W	9.9	15.0	15.6	15.0	16.8	
4	Efficiency (Typ) (*1)	100VAC	%	70	76	80	81	82
		200VAC	%	71	78	83	84	85
5	Input Voltage Range (*2)(*12)	-	85- 265VAC( 47-63Hz) or 120- 370VDC					
6	Input Current (Typ) (*1)	A	0.24 / 0.15		0.34 / 0.17			
7	Inrush Current (Typ) (*1)(*3)	-	15A at 100VAC,30A at 200VAC,Ta=25°C,Cold Start					
8	Output Voltage Range	V	2.97 -3.63	4.5 - 5.5	10.8 - 13.2	13.5 - 16.5	21.6 - 26.4	
9	Maximum Ripple & Noise (*4)(*5)	0≤Ta≤60°C, 35-100% Load	mV	120	120	150	150	150
		-10≤Ta<0°C, 35-100% Load	mV	160	160	180	180	180
		-10<Ta<60°C, 0~35% Load	mV	200	200	240	240	240
10	Maximum Line Regulation (*4)(*6)	mV	20	20	48	60	96	
11	Maximum Load Regulation (*4)(*7)	mV	40	40	96	120	150	
12	No Load Power Consumption	-	Typical 0.2W at 100VAC/200VAC, 0.5W Max					
13	Temperature Coefficient (*4)	-	Less than 0.02% / °C					
14	Over Current Protection (*8)	A	3.15 -	3.15 -	1.37 -	1.05 -	0.74 -	
15	Over Voltage Protection (*9)	V	4.00 - 5.25	5.75 - 7.00	13.8 - 16.2	17.3 - 20.3	27.6 - 32.4	
16	Hold-up Time (Typ) (*1)	-	20ms					
17	Leakage Current (*10)	-	0.15/0.30mA Max. (100VAC / 230VAC 60Hz)					
18	Remote Control	-	-					
19	Parallel Operation	-	-					
20	Series Operation	-	Possible					
21	Operating Temperature (*11)	-	Convection : -10 - +60°C (-10 - +40°C:100%, +50°C:70%, +60°C:40%)					
22	Operating Humidity	-	30 - 90%RH (No Condensing)					
23	Storage Temperature	-	-30 - +75°C					
24	Storage Humidity	-	10 - 95%RH (No Condensing)					
25	Cooling	-	Convection Cooling					
26	Withstand Voltage	-	Input - FG : 2kVAC (10mA), Input - Output : 3kVAC (10mA) Output - FG : 500VAC (20mA) for 1min					
27	Isolation Resistance	-	More than 100MΩ at 25°C and 70%RH Output - FG : 500VDC					
28	Vibration	-	At no operating, 10 - 55Hz (Sweep for 1min) 19.6m/s <sup>2</sup> Constant, X,Y,Z 1hour each.					
29	Shock	-	Less than 196.1m/s <sup>2</sup>					
30	Safety	-	Approved by UL62368-1, CSA62368-1, EN62368-1, UL60950-1, CSA60950-1, EN60950-1 (Expire date of 60950-1 : 20/12/2020), EN50178(OV II) Designed to meet DENAN at 100VAC only.					
31	Conducted Emission	-	Designed to meet EN55011/EN55032-B, FCC-B, VCCI-B					
32	Radiated Emission	-	Designed to meet EN55011/EN55032-B, FCC-B, VCCI-B					
33	Immunity	-	Designed to meet IEC61000-6-2 IEC61000-4-2, -3, -4, -5, -6, -8, -11					
34	Weight (Typ)	g	125					
35	Size (W x H x D)	mm	60 x 32 x 107.5 ( Refer to Outline Drawing )					

\*Read instruction manual carefully, before using the power supply unit.

=NOTES=

- \*1. At 100VAC/200VAC, Ta=25°C, nominal output voltage and maximum output power.
- \*2. For cases where conformance to various safety specs (UL, CSA, EN) are required, to be described as 100 - 240VAC(50/60Hz).
- \*3. Not applicable for the in-rush current to noise filter for less than 0.2ms.
- \*4. Please refer to Fig. A for measurement of Vo, line & load regulation and ripple voltage.
- \*5. For start up at low ambient temperature and low input voltage, output ripple noise might not meet specification. However, specification can be met after one second.
- \*6. 85 - 265VAC, constant load.
- \*7. No load-Full load, constant input voltage.
- \*8. Current limiting (hiccup) with automatic recovery.  
Avoid to operate at over load or short circuit condition for more than 30seconds.
- \*9. OVP circuit will shut down output , manual reset (Re power on).
- \*10. Measured by the each measuring method of UL, CSA, EN and DENAN(at 60Hz), Ta=25°C.
- \*11. Output Deratings
  - Derating at standard mounting. Refer to output derating curve (CA791-01-02/A\_).
  - When forced air cooling, refer to derating curve(CA791-01-02/A\_).
  - Load (%) is percent of maximum output power or maximum output current, do not exceed its derating of maximum load.
- \*12. Output Derating needed when input voltage less than 90VAC. Refer to output derating vs. input voltage (CA791-01-03/A\_).

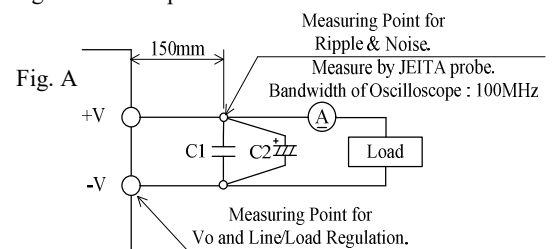

C1 : Film Cap. 0.1 μF  
C2 : Elec. Cap. 100 μF

ZWS15B/A

OUTPUT DERATING

CA791-01-02/A

\*COOLING: CONVECTION COOLING

Ta (°C)	LOADING CONDITION(%)	
	Mounting A,B,C,D	Mounting E,F
-10~35	100	100
40	100	90
50	70	70
60	40	40

\*COOLING: FORCED AIR COOLING

Ta (°C)	LOADING CONDITION(%)
	All Mounting (A,B,C,D,E,F)
-10~50	100
60	70

Air Velocity ≥ 0.7m/s: Air must flow through component side.

\*COOLING: CONVECTION COOLING

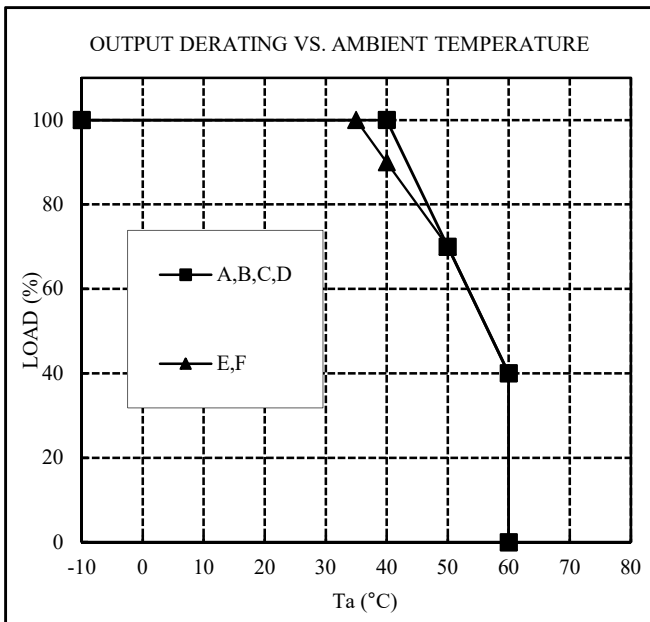

\*COOLING: FORCED AIR COOLING

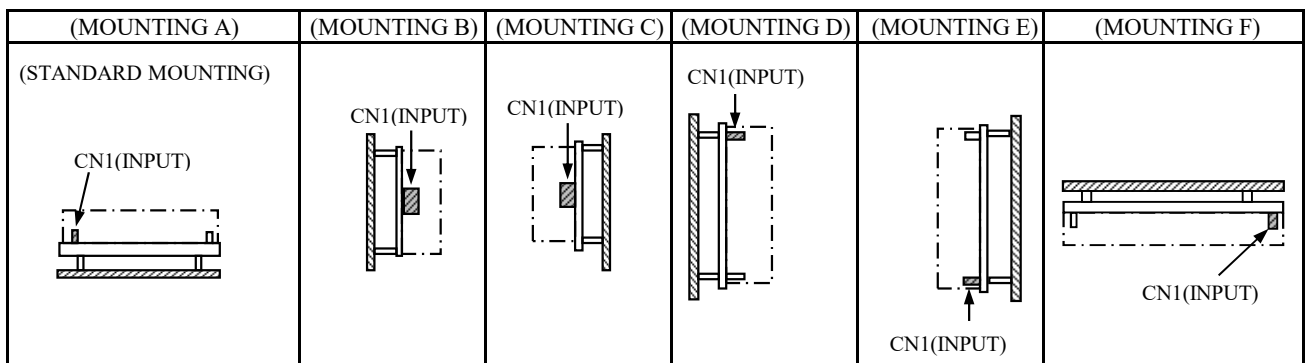
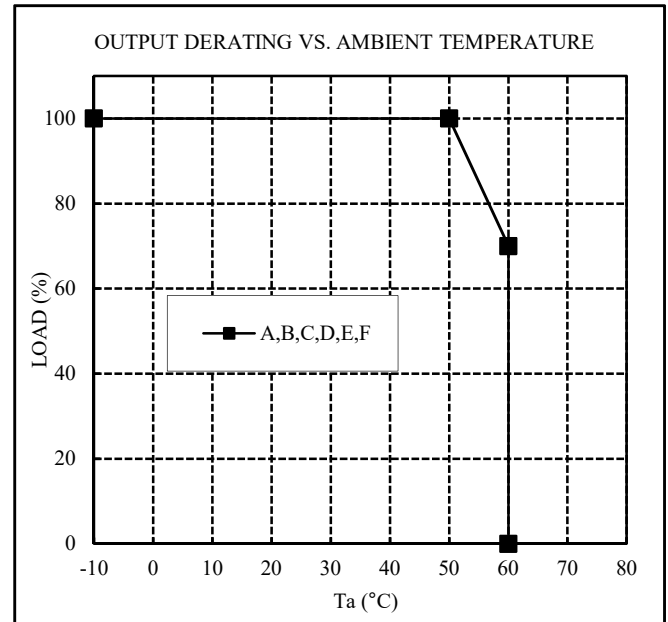

**ZWS15B/A**

OUTPUT DERATING

CA791-01-03/A

Input voltage	LOADING CONDITION(%)
	All Mounting (A,B,C,D,E,F)
85VAC	90
90VAC-265VAC	100

