

ZWX300/L1

SPECIFICATIONS(1/2)

A236-01-01/L1-B

(This specifications sheet also to other option model /L2.)

ITEMS		MODEL	ZWX300/L1						
			V1	V2	V3-1	V3-2	V4	V5 (5V SB)	
1	Nominal Output Voltage	V	+3.3	+5	+12	+12	-12	+5	
2	Minimum Output Current	A	0	0	0	0	0	0	
3	Maximum Output Current (Convection)	A	10.0	6.0	4.0	8.0	0.2	1.4	
4	Maximum Output Power Each CH (Convection)	W	33.0	30.0	48.0	96.0	2.4	7.0	
			Combined 131W						
5	Total Output Power (Convection)	W	150						
6	Maximum Output Current (Forced Air)	A	14.0	8.4	5.6	11.2	0.4	2.0	
7	Maximum Output Power Each CH (Forced Air)	W	46.2	42.0	67.2	134.4	4.8	10.0	
8	Total Output Power (Forced Air)	W	255						
9	Peak Output Current (*1)	A	20.0	12.0	8.0	16.0	0.4	2.0	
10	Peak Output Power Each CH (*1)	W	66.0	60.0	96.0	192.0	4.8	10.0	
			Combined 264W						
11	Total Peak Output Power (*1)	W	300						
12	Efficiency (100/200VAC)(Typ) (*2)	-	81%/84%						
13	Input Voltage Range (*4)	-	85-265VAC (47-63Hz)						
14	Input Current (100/200VAC) (Typ) (*2)	-	3.2A/1.6A						
15	Inrush Current (100/200VAC) (Typ) (*5)	-	14A/28A at Cold Start (Ta=25°C)						
16	PFHC	-	Designed to meet IEC61000-3-2						
17	Power Factor (100/200VAC)(Typ) (*2)	-	0.99/0.93						
18	Output Voltage Accuracy	%	±5	±5	±5	±5	±5	±5	
19	Output Voltage Range	-	Fixed	Fixed	Fixed	Fixed	Fixed	Fixed	
20	Maximum Ripple & Noise	-10≤Ta<0°C	mV	160	180	180	180	160	160
		0≤Ta≤50°C	mV	120	150	150	150	120	120
21	Maximum Line Regulation (*3,*6,*7)	mV	20	48	48	48	20	20	
22	Maximum Load Regulation (*3,*6,*8)	mV	100	300	300	300	100	100	
23	Over Current Protection (*9)	A	14.7-	8.82-	5.88-	11.8-	0.42-	2.1-	
24	Over Voltage Protection (*10)	-	V1 : 114%-130%(3.76-4.3V), V2 : 115%-140%(5.74-7V) V3-1, V3-2 : 112%-130%(13.4-15.6V)						
25	Hold-up Time (Typ) (*2)	-	20ms at 100VAC						
26	Leakage Current (*3,*11)	-	Less than 0.75mA						
27	Remote Sensing	-	Possible (V1 only)						
28	ON/OFF Control (PS_ON)	-	TTL compatible (H : Output Inhibit, L : Output Enable) : Designed to meet ATX standard.						
29	Series / Parallel Operation	-	-						
30	Operating Temperature (*12)	-	-10 - +50°C : 100%, 60°C : 60%, 70°C : 20%						
31	Operating Humidity	-	30 - 90%RH (No Dewdrop)						
32	Storage Temperature	-	-30 - +85°C						
33	Storage Humidity	-	10 - 95%RH (No Dewdrop)						
34	Cooling (*12)	-	Convection Cooling / Forced air Cooling (System air Cooling) : 0.85 m ³ /min						
35	Withstand Voltage	-	Input-FG : 2kVAC(20mA), Input-Output : 3kVAC(20mA) Output-FG : 500VAC(100mA) for 1min.						
36	Isolation Resistance	-	More than 100MΩ at 25°C and 70%RH Output-FG : 500VDC						
37	Vibration	-	At no operating 10 - 55Hz(Sweep for 1min) 19.6 m/s ² Constant, X,Y,Z 1hour each.						
38	Shock	-	Less than 392 m/s ² at no operating.						
39	Safety	-	Approved by UL60950-1, CSA60950-1, EN60950-1, EN50178(OV II), Designed to meet Den-an Appendix12 (J60950-1)						
40	Conducted Emission (*3)	-	Designed to meet EN55011/EN55022-B, FCC-ClassB, VCCI-B						
41	Radiated Emission (*3)	-	Designed to meet EN55011/EN55022-B, FCC-ClassB, VCCI-B						

ZWX300/L1

SPECIFICATIONS(2/2)

A236-01-02/L1

(This specifications sheet also to other option model /L2.)

ITEMS		MODEL	ZWX300/L1				
			V1	V2	V3-1	V3-2	V4
42	Immunity	-	Designed to meet IEC61000-4-2, -3, -4, -5, -6, -8, -11				
43	Weight (Typ.)	g	950				
44	Size (W x H x D)	mm	121 x 45.5 x 280 (Refer to Outline Drawing)				

*Read instruction manual carefully, before using the power supply unit.

=NOTE=

- *1. Operating time at peak output is less than 5sec.
(Average output power and current are less than maximum output power and current.)
- *2. At total output power (Forced air) (V1=12A, V2=7.0A, V3-1=5.0A, V3-2=9.4A, V4=0.2A, V5=1.0A), Ta=25°C.
- *3. At total output power (Forced air).
- *4. For cases where conformance to various safety specs (UL, CSA, EN) are required, to be described as 100 - 240VAC (50/60Hz).
- *5. Not applicable for the inrush current to Noise Filter for less than 0.2ms.
- *6. Please refer to Fig. A for measurement of line & load regulation and ripple voltage.
- *7. 85 - 265VAC , constant load.
- *8. No load-Full load, constant input voltage.
- *9. Avoid to operate at overload or short circuit condition for more than 30 seconds.
V1,V2,V3-1 and V3-2
: OCP circuit will shut down output except V5 with delay (more than 5s), manual reset (PS_ON reset or re power on.).
V4 : Constant current limit with automatic recovery.
V5 : Constant current limit in conjunction with all output with automatic recovery.
- *10. OVP circuit will shut down output, manual reset (PS_ON reset or re power on.).
- *11. Measured by the each measuring method of UL, CSA, EN and DENAN (at 60Hz), Ta=25°C.
- *12. At forced air cooling, standard mounting. Refer to output derating curve.(A236-01-03_, A236-01-04_)

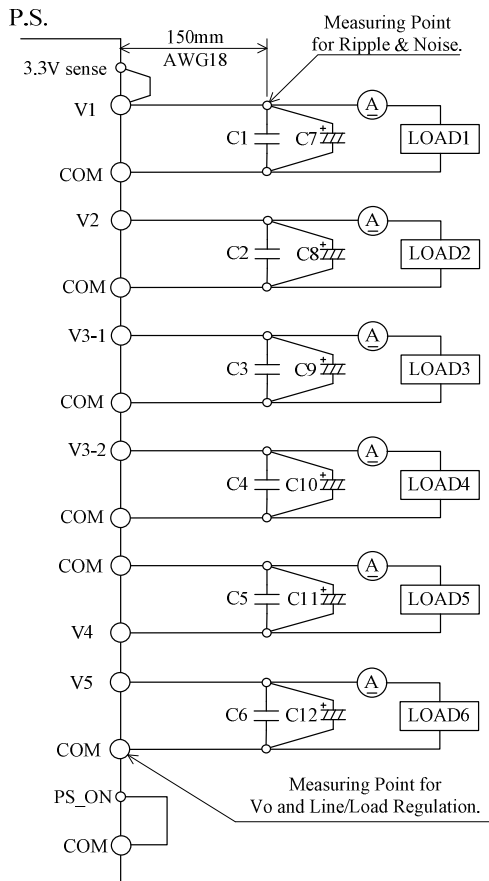

Measure with EIAJ RC-9131 probe.
Bandwidth of scope : 100MHz

	Capacitance
C1,C2,C3,C4,C5,C6 : Film Cap.	0.1 μF
C7,C8,C9,C10,C11,C12 : Elec. Cap.	100 μF

Fig.A