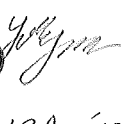
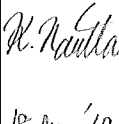

CN200A110-*

EVALUATION DATA

型式データ

DWG.NO. C257-53-01		
承認	査閲	担当
 20 Aug '10	 19 Aug '10	 18 Aug '10

INDEX

1. 測定方法	Evaluation Method	PAGE
1.1	測定回路 Measurement Circuits	T-1
	(1) 静特性、過電流保護特性、出力リップル、ノイズ波形 Steady state characteristics, Over current protection (OCP) characteristics and Output ripple and noise waveform	
	(2) 過渡応答、過電圧保護特性、その他 Dynamic response, Over voltage protection (OVP) characteristics and Other characteristics	
	(3) 入力サージ電流 (突入電流) 特性 Inrush current characteristics	
	(4) EMI 特性 Electro-Magnetic Interference characteristics	
1.2	使用測定機器 List of equipment used	T-3
2. 特性データ	Characteristics	
2.1	静特性 Steady state data	
	(1) 入力・負荷・温度変動 Regulation - line and load, temperature drift	T-4
	(2) 出力電圧・リップル、ノイズ電圧 対 入力電圧 Output voltage and ripple and noise voltage vs. Input voltage	T-6
	(3) 入力電流・効率 対 出力電流 Input current and Efficiency vs. Output current	T-8
	(4) 効率 対 入力電圧 Efficiency vs. Input voltage	T-10
	(5) 効率 対 ベースプレート温度 Efficiency vs. Baseplate temperature	T-12
	(6) 起動・停止電圧特性 Start and Stop voltage characteristics	T-14
2.2	待機電力特性 Standby power characteristics	T-16
2.3	通電ドリフト特性 Warm up voltage drift characteristics	T-18
2.4	過電流保護特性 Over current protection (OCP) characteristics	T-20
2.5	過電圧保護特性 Over voltage protection (OVP) characteristics	T-22
2.6	出力立ち上がり、立ち下がり特性 Output rise and fall characteristics	T-24
2.7	過渡応答(負荷急変)特性 Dynamic load response characteristics	T-32
2.8	入力サージ電流(突入電流)特性 Inrush current characteristics	T-34
2.9	出力リップル、ノイズ波形 Output ripple and noise waveform	T-35
2.10	EMI特性 Electro-Magnetic Interference characteristics	T-37

使用記号 Terminology used

Definition		
V _{in}	入力電圧	Input voltage
V _o	出力電圧	Output voltage
V _{cnt}	CNT電圧	CNT voltage
I _{in}	入力電流	Input current
I _o	出力電流	Output current
T _{bp}	ベースプレート温度	Baseplate temperature
T _a	周囲温度	Ambient temperature
f	周波数	Frequency

1. 測定方法 Evaluation Method

1.1 測定回路 Measurement Circuits

- (1) 静特性、過電流保護特性、出力リップル、ノイズ波形
Steady state characteristics, Over current protection (OCP) characteristics and Output ripple and noise waveform

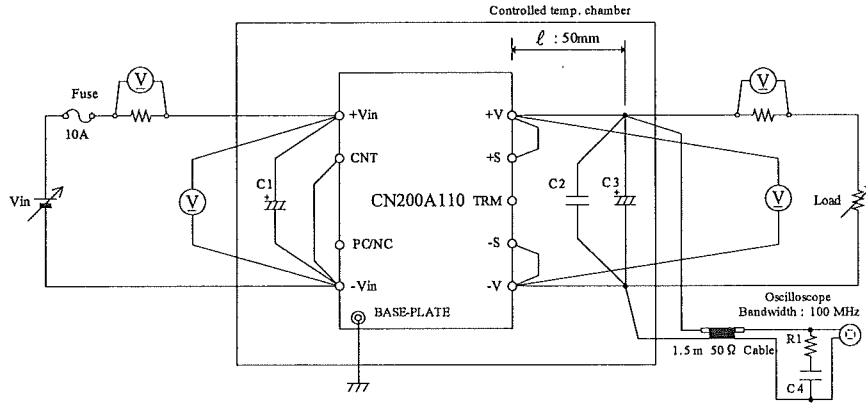

- (2) 待機電力、通電ドリフト、過電圧保護、出力立ち上がり、立ち下り、過渡応答特性
Standby power, Warm up voltage drift, Over voltage protection (OVP), Output rise and fall and Dynamic response characteristics

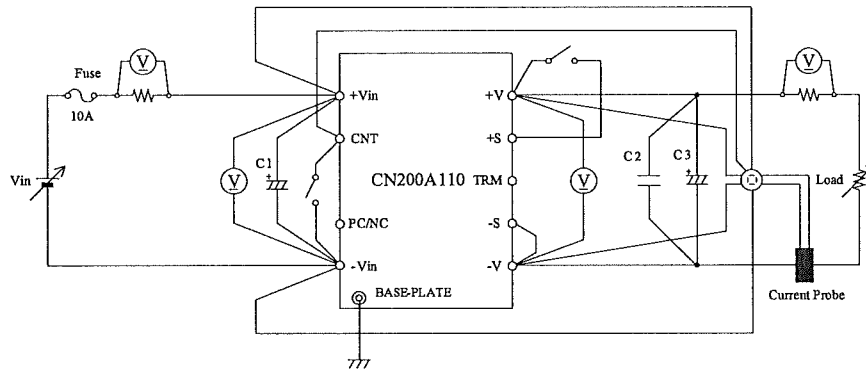

- (3) 入力サージ電流（突入電流）特性
Inrush current characteristics

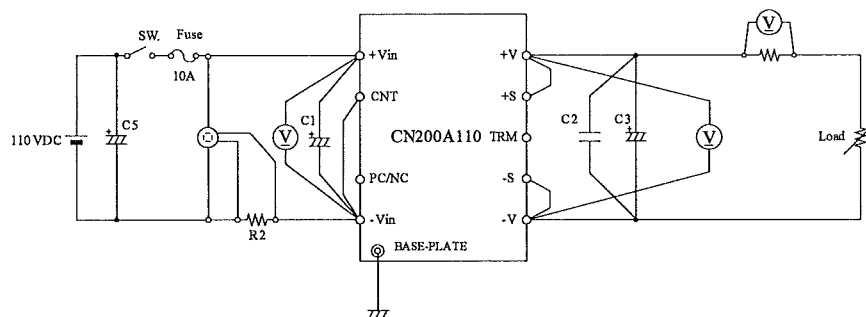

C1 : 100uF Electrolytic Capacitor

C2 : 2.2μF Ceramic Capacitor

C3 : 5V-2200uF Electrolytic Capacitor

: 12V-1000uF Electrolytic Capacitor

: 15V-1000uF Electrolytic Capacitor

: 24V-470uF Electrolytic Capacitor

C4 : 4700pF Ceramic Capacitor

C5 : 8000uF Electrolytic Capacitor

R1 : 50 Ω

R2 : 0.01 Ω

(4) EMI特性 Electro-Magnetic Interference characteristics

(a) 雑音端子電圧 (帰還ノイズ) Conducted Emission Noise

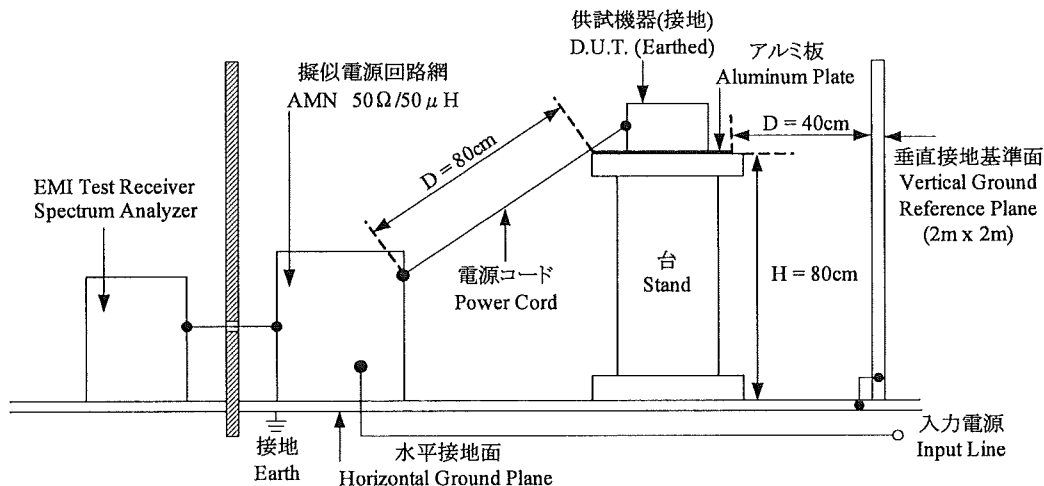

(b) 雑音電界強度 (輻射ノイズ) Radiated Emission Noise

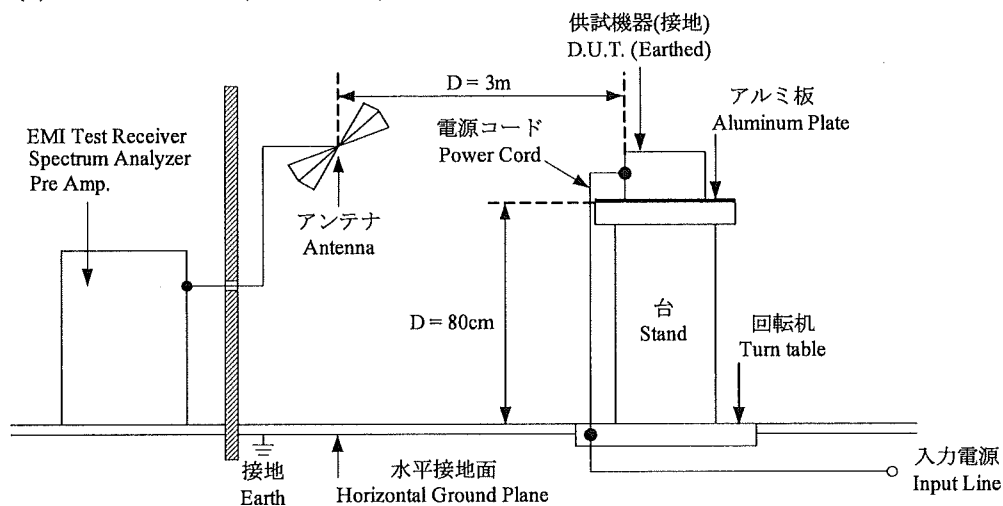

* 入出力ケーブルとしてシールドケーブルを使用
Shielded cable used to input and output cable.

VCCI class A対応アプリケーションシステム
VCCI class A application system

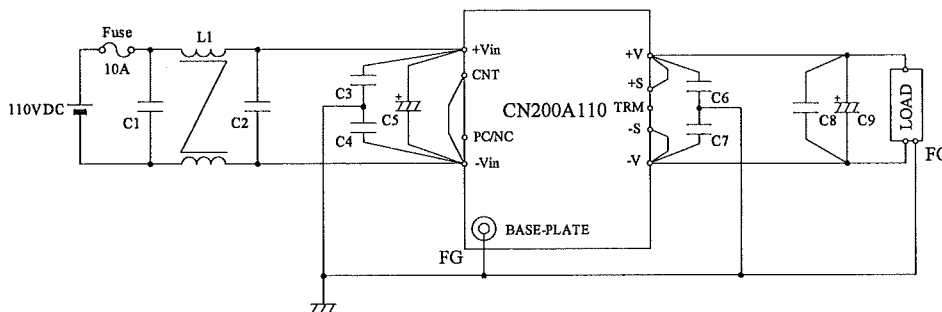

- | | |
|--|---------------------------------------|
| C1, C2 : 2.2μF Film Capacitor | C9 : 5V-2200μF Electrolytic Capacitor |
| C3, C4 : 4700pF Ceramic Capacitor x 2 parallel | : 12V-1000μF Electrolytic Capacitor |
| C5 : 100μF Electrolytic Capacitor | : 15V-1000μF Electrolytic Capacitor |
| C6, C7 : 4700pF Ceramic Capacitor x 2 parallel | : 24V-470μF Electrolytic Capacitor |
| C8 : 2.2μF Ceramic Capacitor | L1 : 3.0mH |

1.2 使用測定機器 List of equipment used

	EQUIPMENT USED	MANUFACTURER	MODEL NO.
1	OSCILLOSCOPE	TEKTRONIX	TDS3012
2	DIGITAL STORAGE OSCILLOSCOPE	LECROY	WR6050A
3	DATA ACQUISITION / SWITCH UNIT	AGILENT	34970A
4	CURRENT PROBE	TEKTRONIX	A6303
5	SHUNT RESISTER	YOKOGAWA ELECT.	2215
6	CONTROLLED TEMP. CHAMBER	ESPEC CORP.	SU-261
7	SPECTRUM ANALYZER EMI TEST RECEIVER	ROHDE & SCHWARZ	ESCI
8	AMN	SCHWARZBECK	NNLK8121
9	ANTENNA(BICONICAL ANTENNA)	TESEQ	CBL6111D
10	DYNAMIC DUMMY LOAD	TAKASAGO	FK-1000L
11	AC POWER SUPPLY	TAKASAGO	AA-2000XG

2. 特性データ Characteristics

2.1 静特性 Steady state data

(1) 入力・負荷・温度変動 Regulation - line and load, Temperature drift

5V

1. Regulation - line and load Condition Tbp : 25°C

Io \ Vin	60VDC	110VDC	160VDC	Line regulation	
0%	5.003V	5.003V	5.003V	0mV	0.000%
50%	5.003V	5.002V	5.002V	1mV	0.020%
100%	5.002V	5.001V	5.001V	1mV	0.020%
Load regulation	1mV	2mV	2mV		
	0.020%	0.040%	0.040%		

2. Temperature drift

Conditions Vin : 110VDC

Io : 100%

Tbp	-40°C	+25°C	+100°C	Temperature stability	
Vo	5.010V	5.001V	4.997V	13mV	0.260%

12V

1. Regulation - line and load Condition Tbp : 25°C

Io \ Vin	60VDC	110VDC	160VDC	Line regulation	
0%	12.006V	12.005V	12.005V	1mV	0.008%
50%	12.004V	12.003V	12.002V	2mV	0.017%
100%	12.001V	12.001V	12.000V	1mV	0.008%
Load regulation	5mV	4mV	5mV		
	0.042%	0.033%	0.042%		

2. Temperature drift

Conditions Vin : 110VDC

Io : 100%

Tbp	-40°C	+25°C	+100°C	Temperature stability	
Vo	12.037V	12.001V	11.980V	57mV	0.475%

(1) 入力・負荷・温度変動 Regulation - line and load, Temperature drift

15V

1. Regulation - line and load Condition Tbp : 25°C

Io \ Vin	60VDC	110VDC	160VDC	Line regulation	
0%	14.991V	14.992V	14.991V	1mV	0.007%
50%	14.990V	14.990V	14.989V	1mV	0.007%
100%	14.988V	14.988V	14.987V	1mV	0.007%
Load regulation	3mV	4mV	4mV		
	0.020%	0.027%	0.027%		

2. Temperature drift

Conditions Vin : 110VDC

Io : 100%

Tbp	-40°C	+25°C	+100°C	Temperature stability	
Vo	15.019V	14.988V	14.972V	47mV	0.313%

24V

1. Regulation - line and load Condition Tbp : 25°C

Io \ Vin	60VDC	110VDC	160VDC	Line regulation	
0%	24.005V	24.004V	24.003V	2mV	0.008%
50%	24.003V	24.002V	24.001V	2mV	0.008%
100%	24.000V	23.999V	23.998V	2mV	0.008%
Load regulation	5mV	5mV	5mV		
	0.021%	0.021%	0.021%		

2. Temperature drift

Conditions Vin : 110VDC

Io : 100%

Tbp	-40°C	+25°C	+100°C	Temperature stability	
Vo	24.053V	23.999V	23.965V	88mV	0.367%

(2) 出力電圧・出力リップル、ノイズ電圧 対 入力電圧

Output voltage and ripple and noise voltage vs. Input voltage

Conditions I_o : 100 %
 T_{bp} : -40 °C ---
 : 25 °C - · - · -
 : 100 °C ———

5V

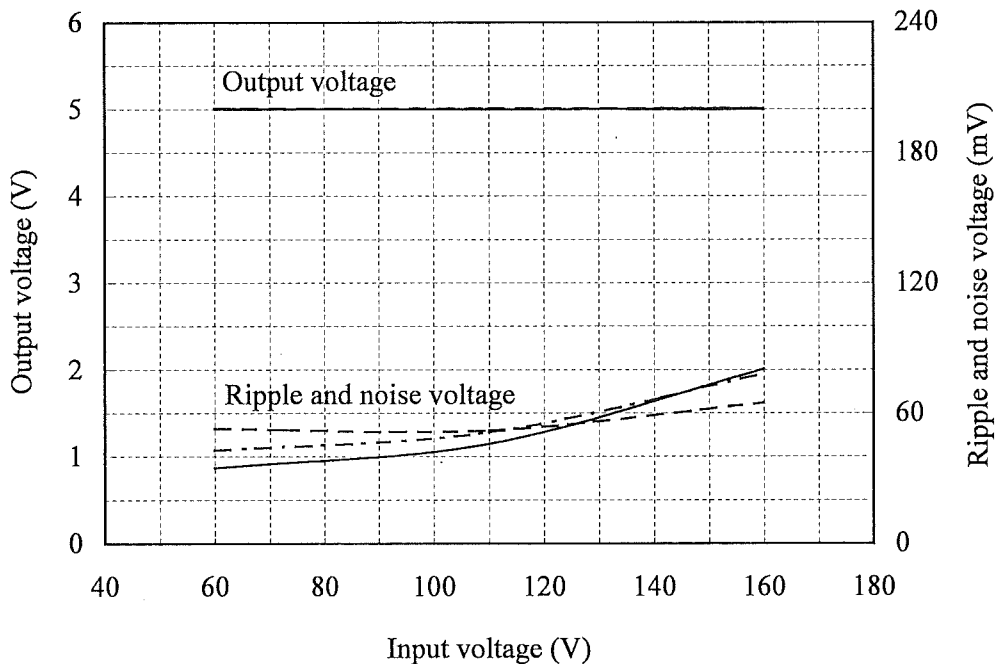

12V

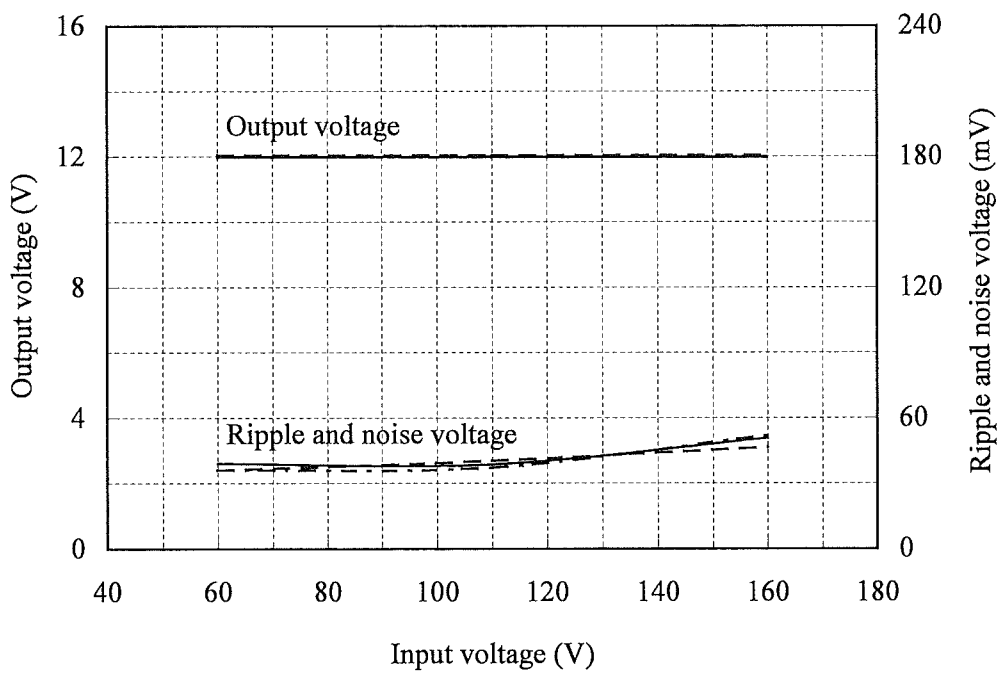

(2) 出力電圧・出力リップル、ノイズ電圧 対 入力電圧

Output voltage and ripple and noise voltage vs. Input voltage

Conditions I_o : 100 %

T_{bp} : -40 °C

: 25 °C

: 100 °C



15V

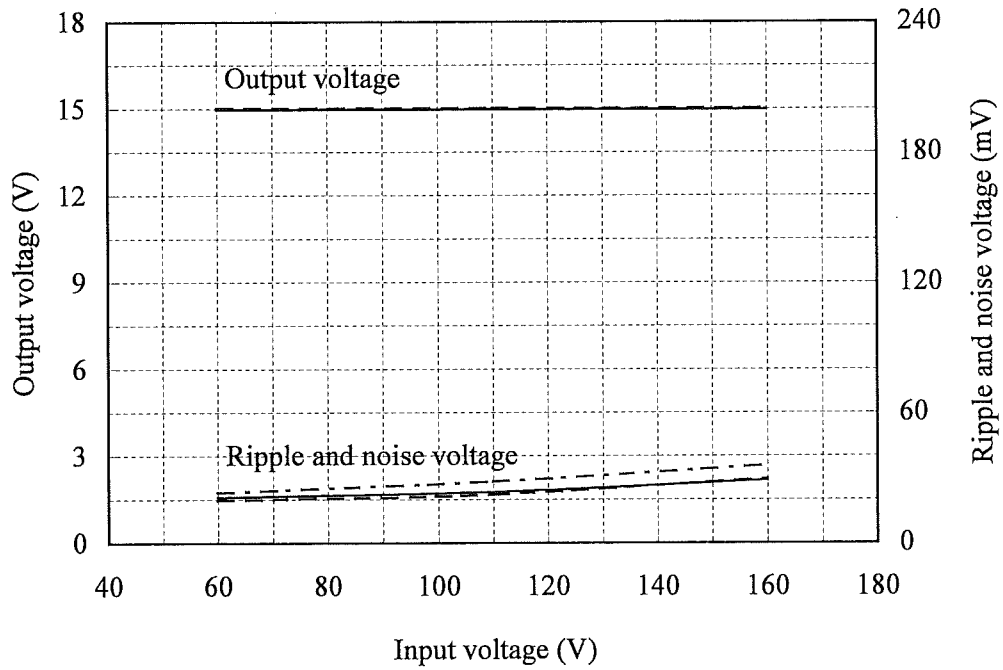

24V

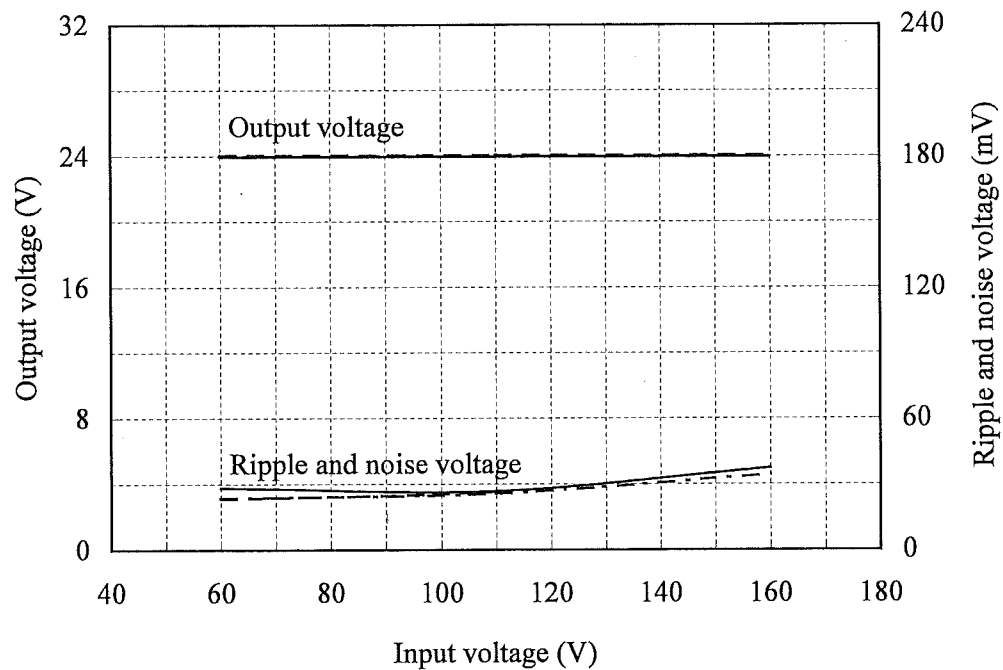

(3) 入力電流・効率 対 出力電流

Input current and Efficiency vs. Output current

Conditions Vin : 60 VDC -----
 : 110 VDC - - - - -
 : 160 VDC _____
 Tbp : 25 °C

5V

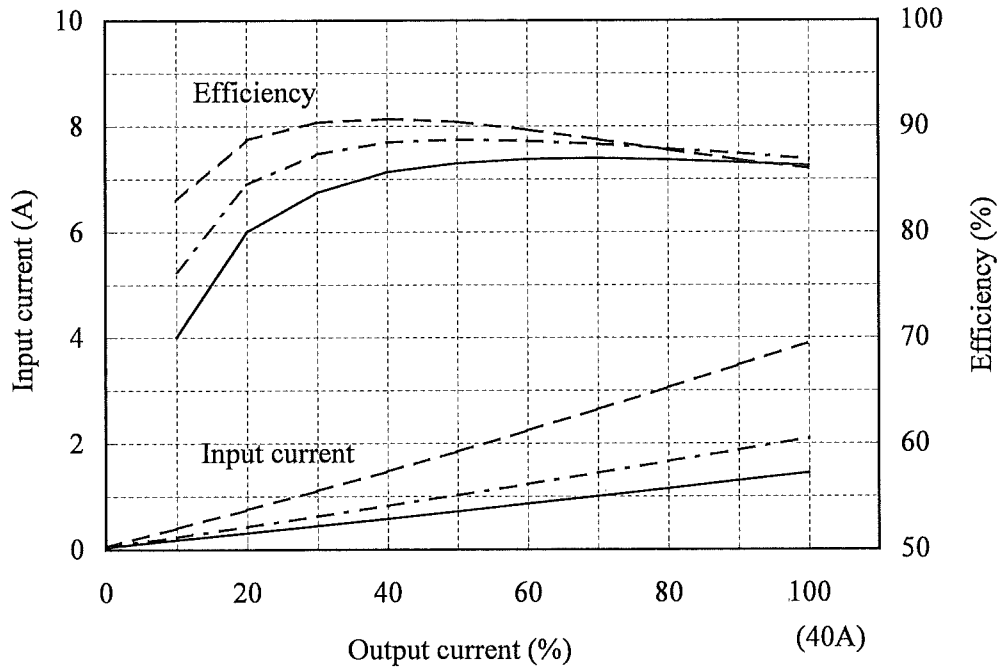

12V

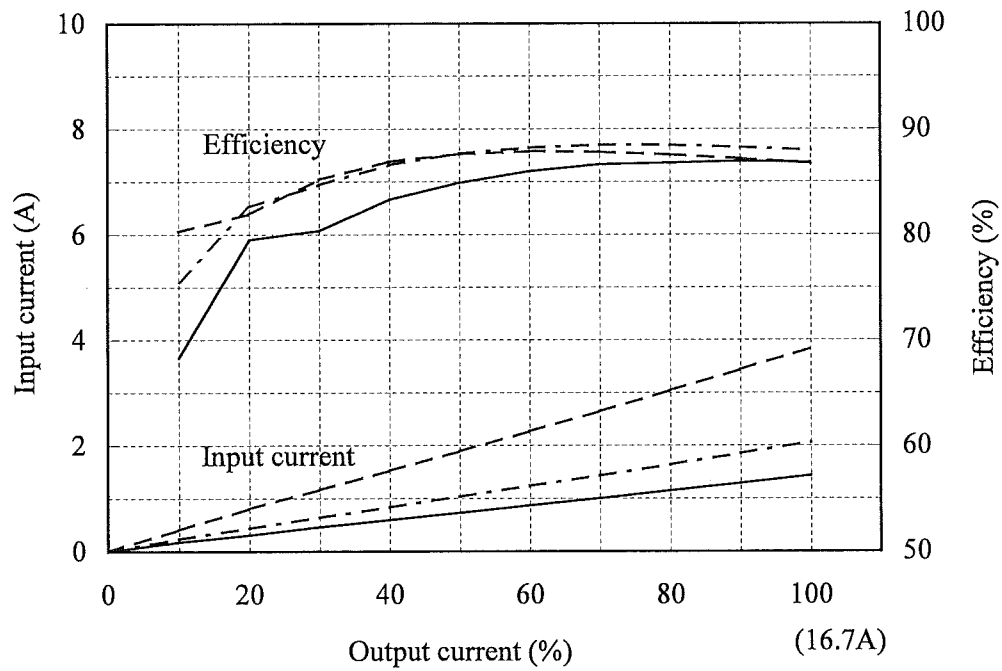

(3) 入力電流・効率 対 出力電流

Input current and Efficiency vs. Output current

Conditions Vin : 60 VDC -----
 : 110 VDC - - - - -
 : 160 VDC _____
 Tbp : 25 °C

15V

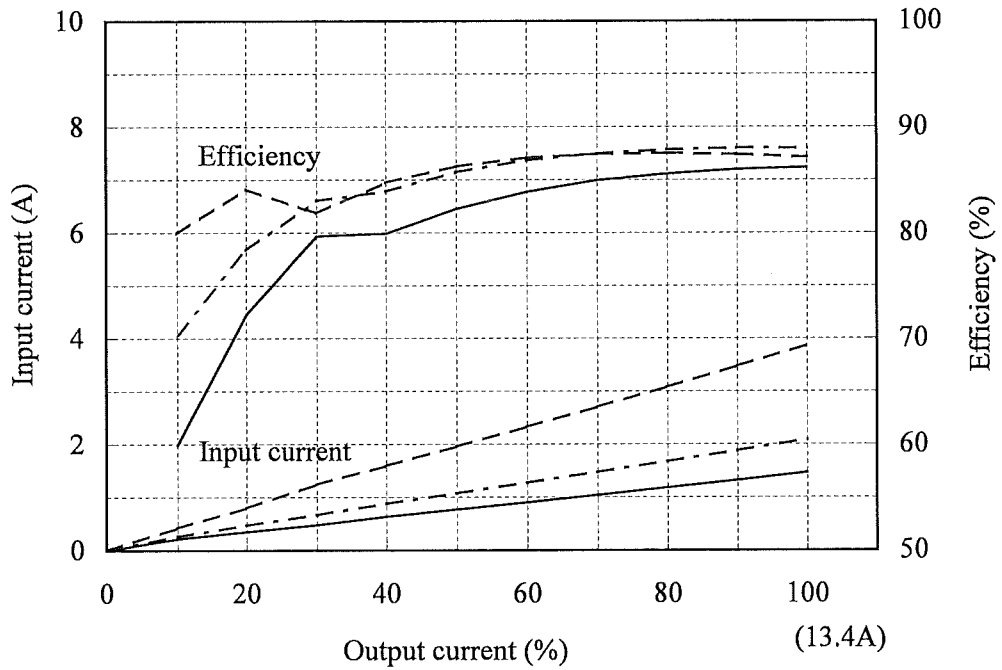

24V

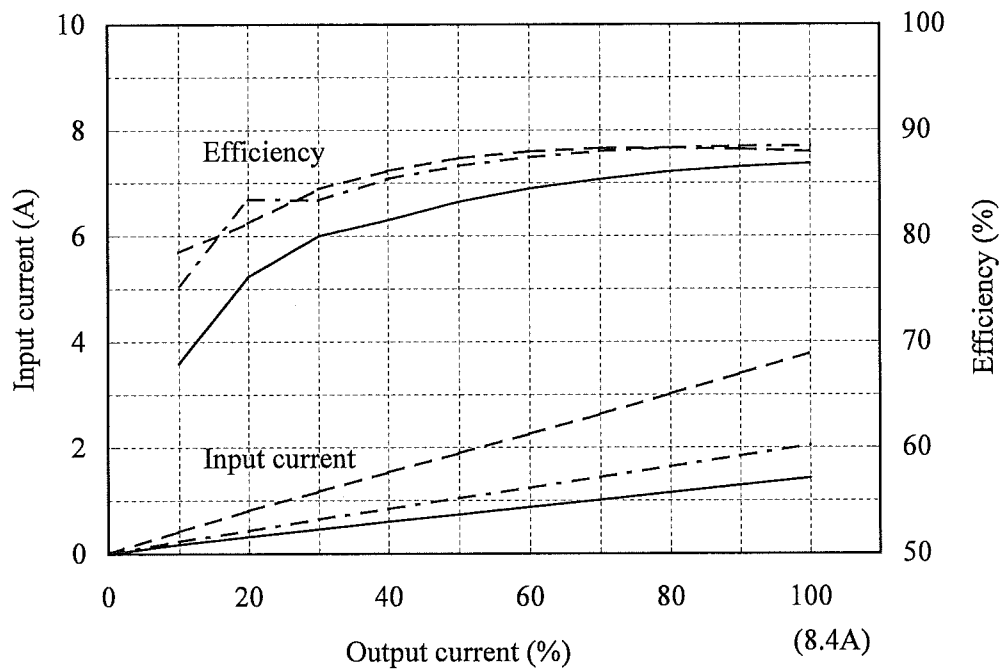

(4) 効率 対 入力電圧

Efficiency vs. Input voltage

Conditions Io : 50 % ----
 : 100 % ----
 Tbp : 25 °C

5V

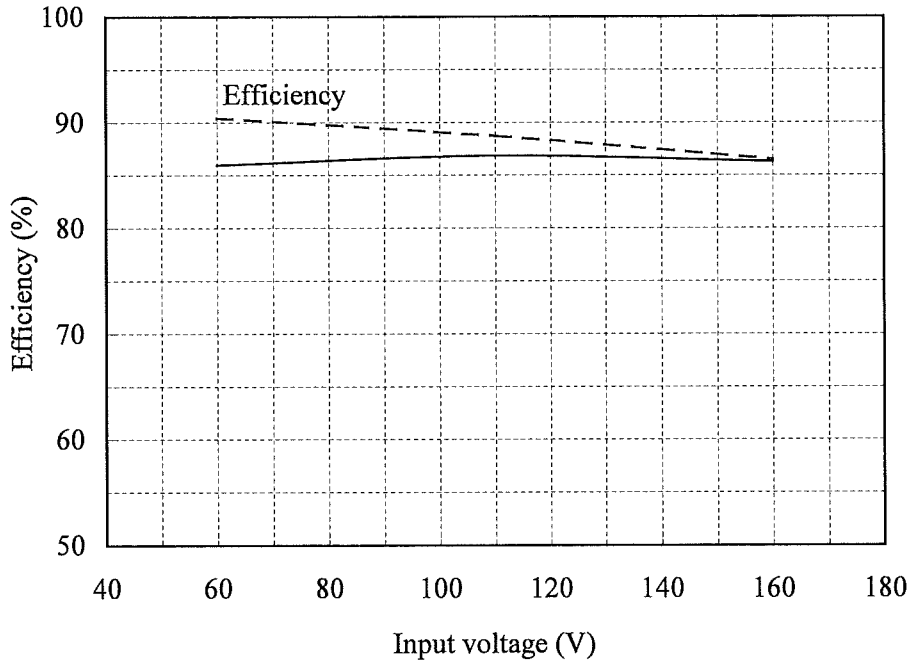

12V

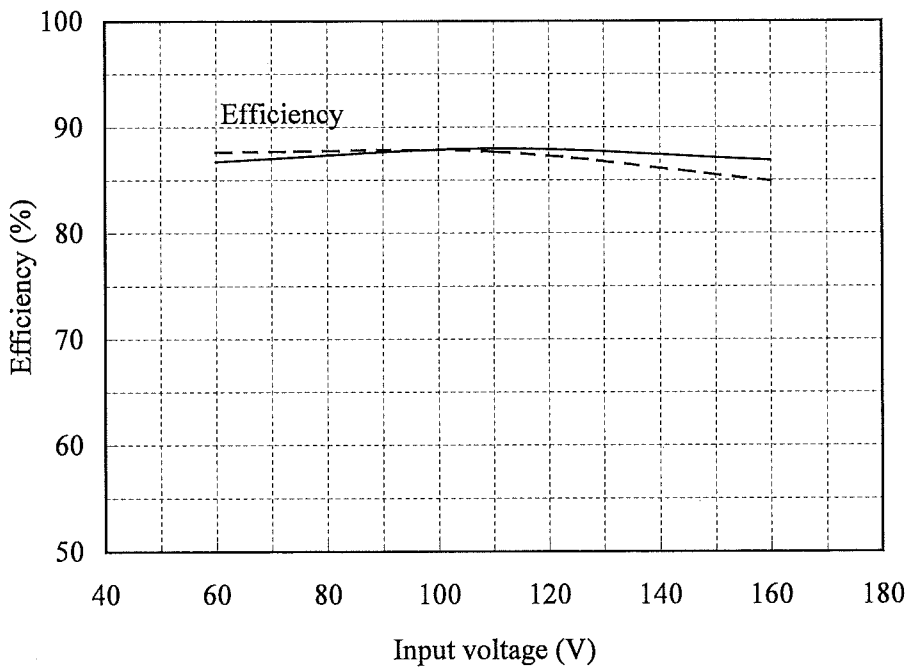

(4) 効率 対 入力電圧
Efficiency vs. Input voltage

Conditions Io : 50 % ----
 : 100 % ——
 Tbp : 25 °C

15V

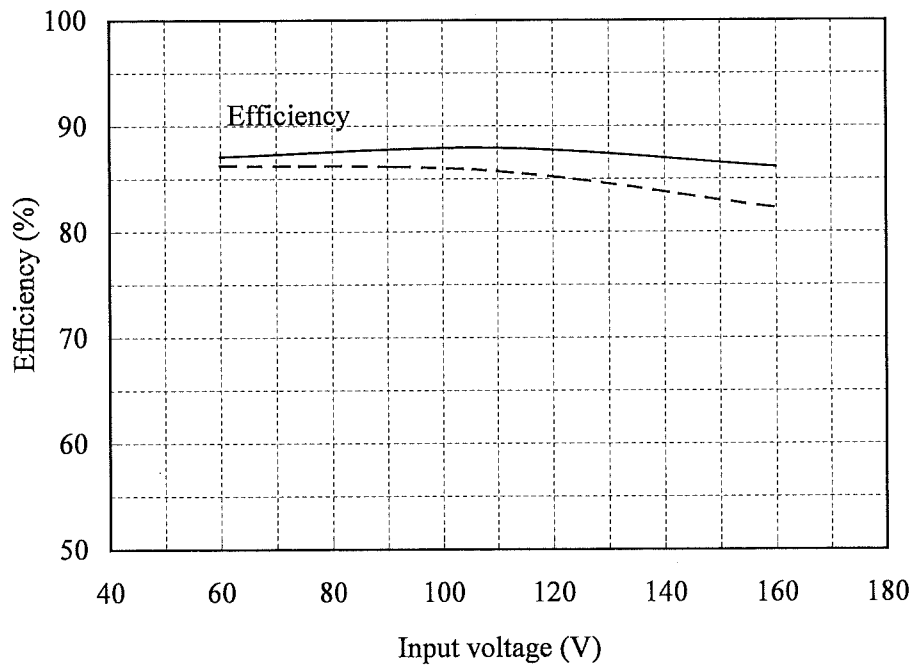

24V

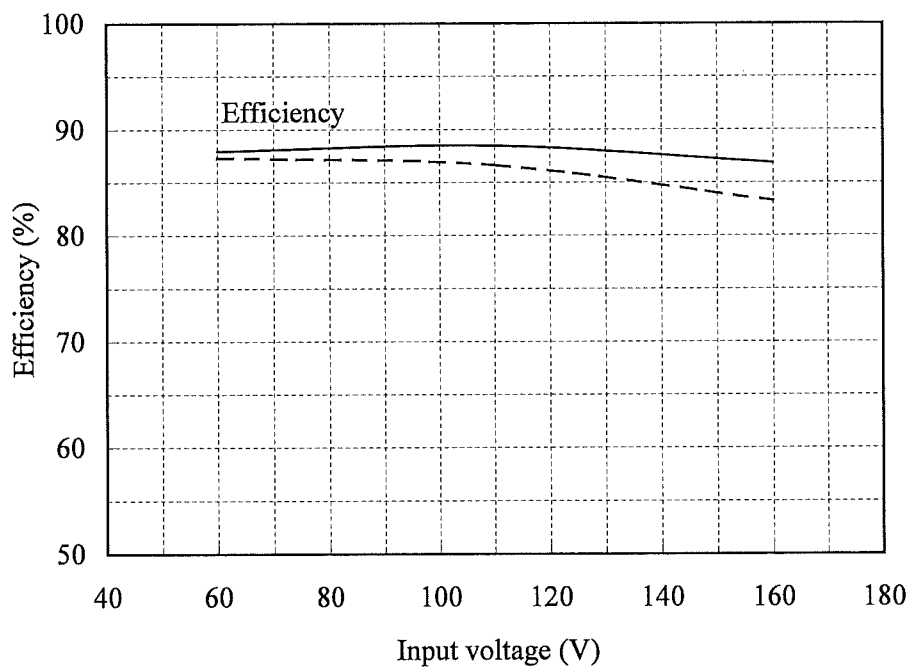

(5) 効率対ベースプレート温度
Efficiency vs. Baseplate temperature

Conditions Vin : 110 VDC
Io : 100 %

5V

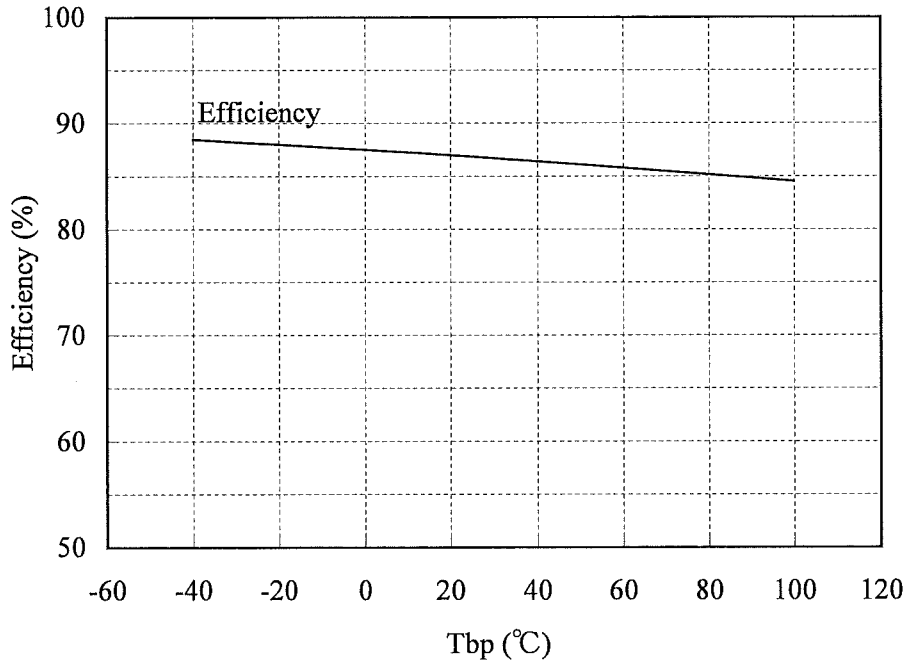

12V

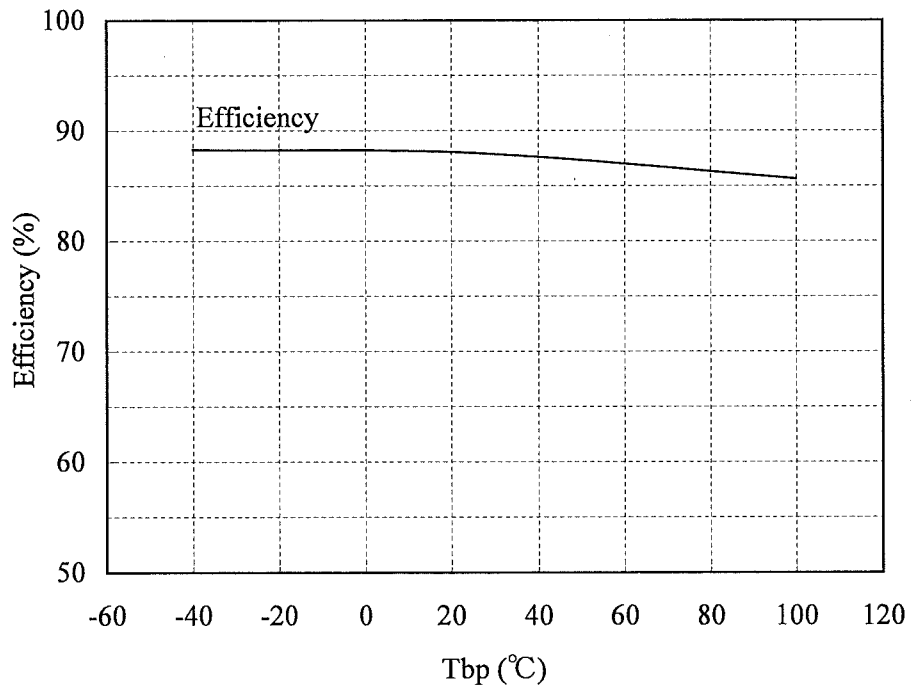

(5) 効率対 ベースプレート温度
Efficiency vs. Baseplate temperature

Conditions Vin : 110 VDC
Io : 100 %

15V

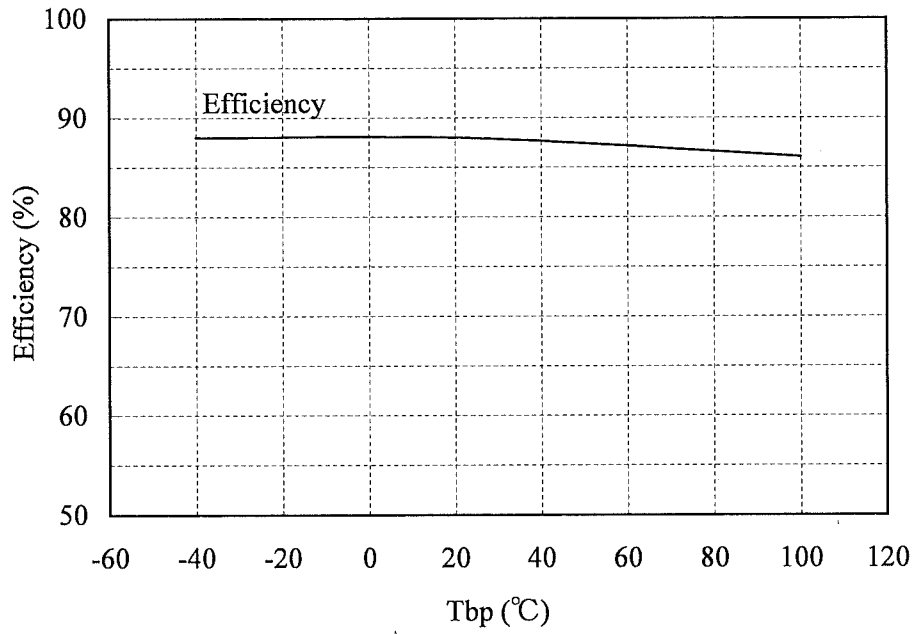

24V

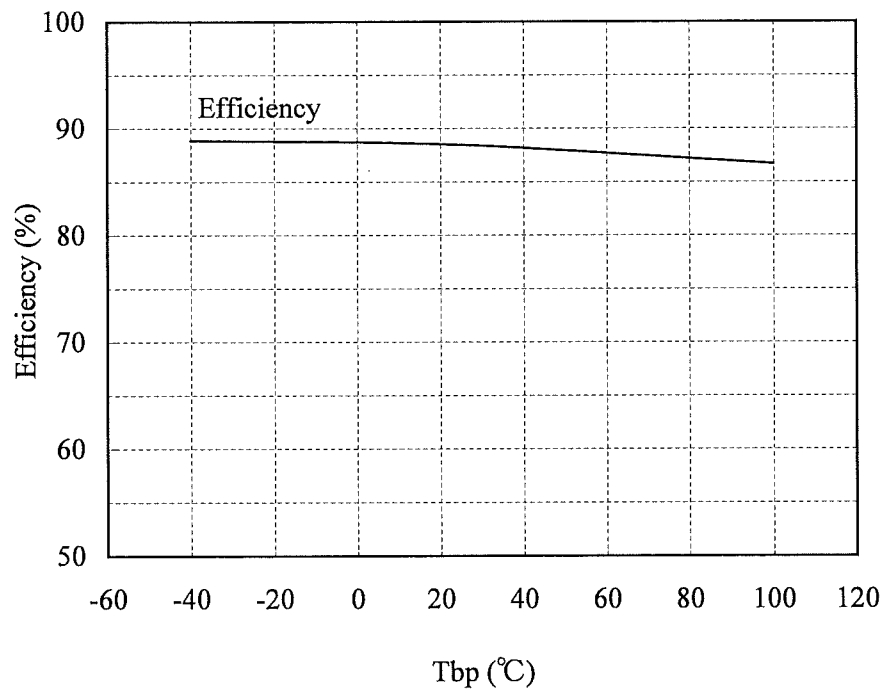

(6) 起動・停止電圧特性
Start and Stop voltage characteristics

出力電圧 対 入力電圧
Output voltage vs. Input voltage

Conditions I_o : 100 %
 T_{bp} : 25 °C

入力電流 対 入力電圧
Input current vs. Input voltage

Conditions I_o : 100 %
 T_{bp} : 25 °C

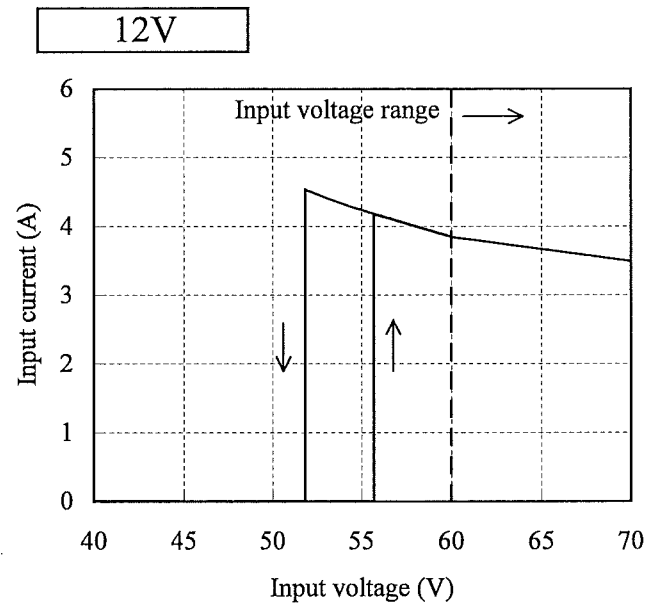
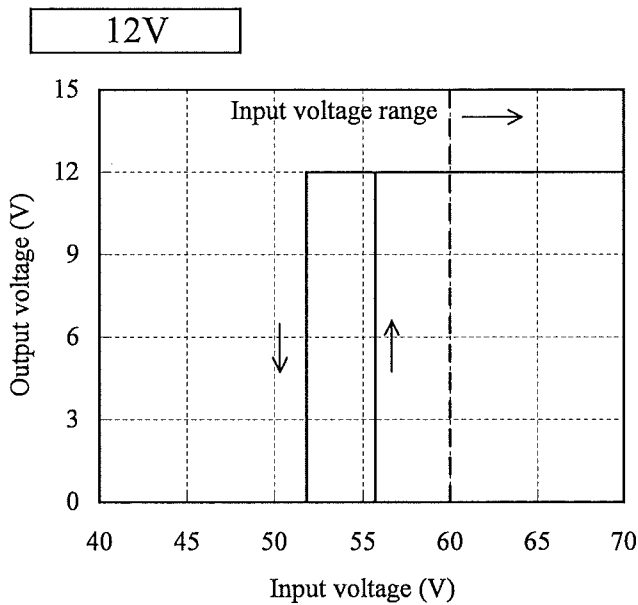
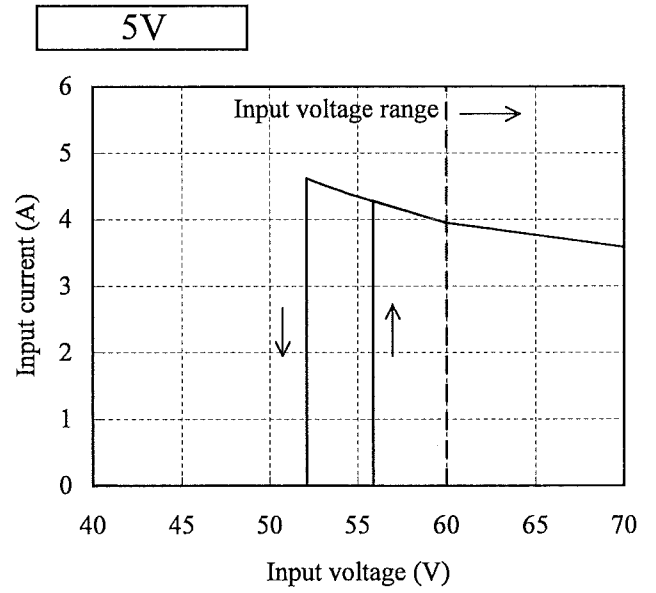
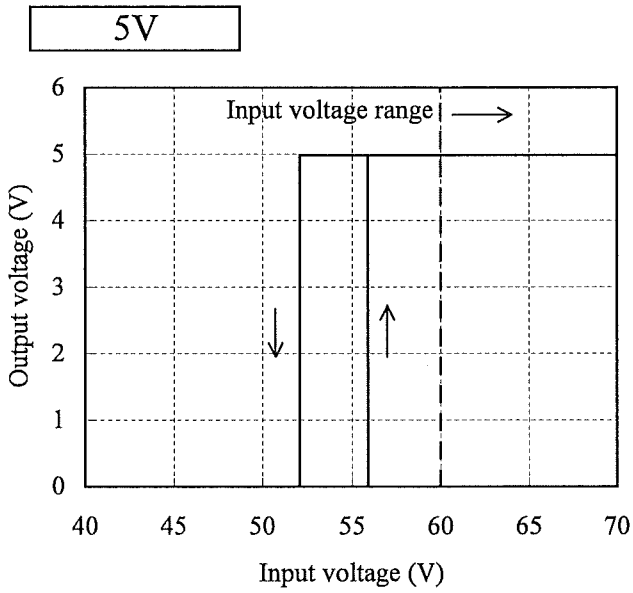

(6) 起動・停止電圧特性
Start and Stop voltage characteristics

出力電圧 対 入力電圧
Output voltage vs. Input voltage

Conditions I_o : 100 %
 T_{bp} : 25 °C

入力電流 対 入力電圧
Input current vs. Input voltage

Conditions I_o : 100 %
 T_{bp} : 25 °C

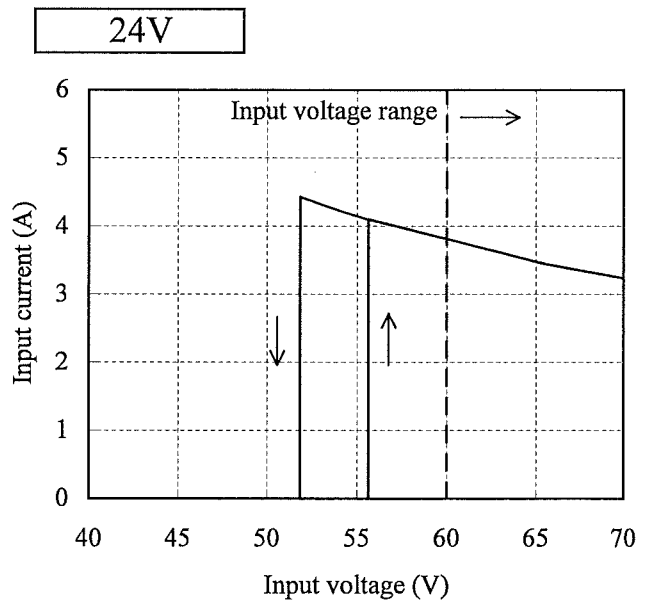
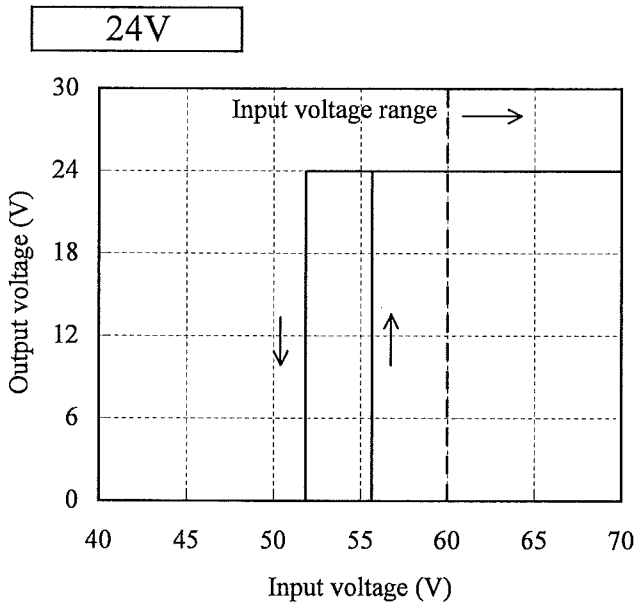
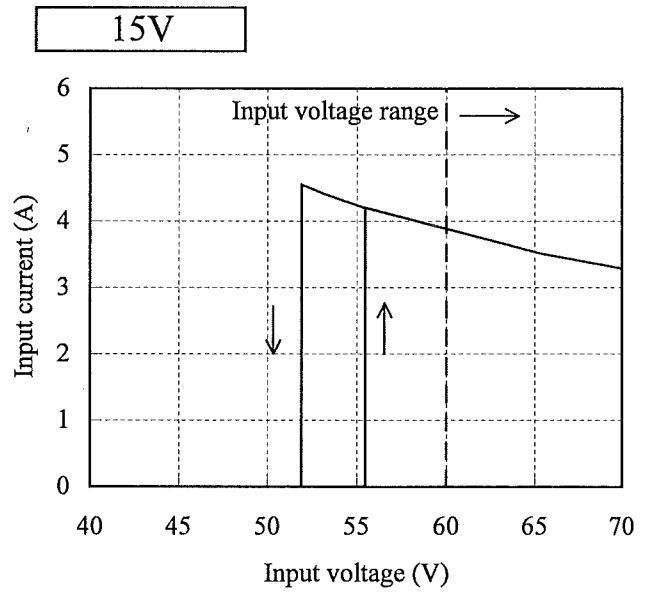
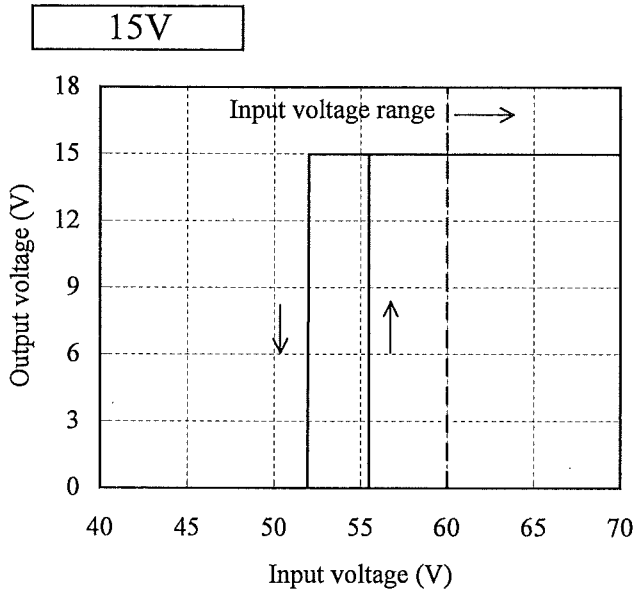

2.2 待機電力特性

Standby power characteristics

Condition T_{bp} : 25 °C

5V

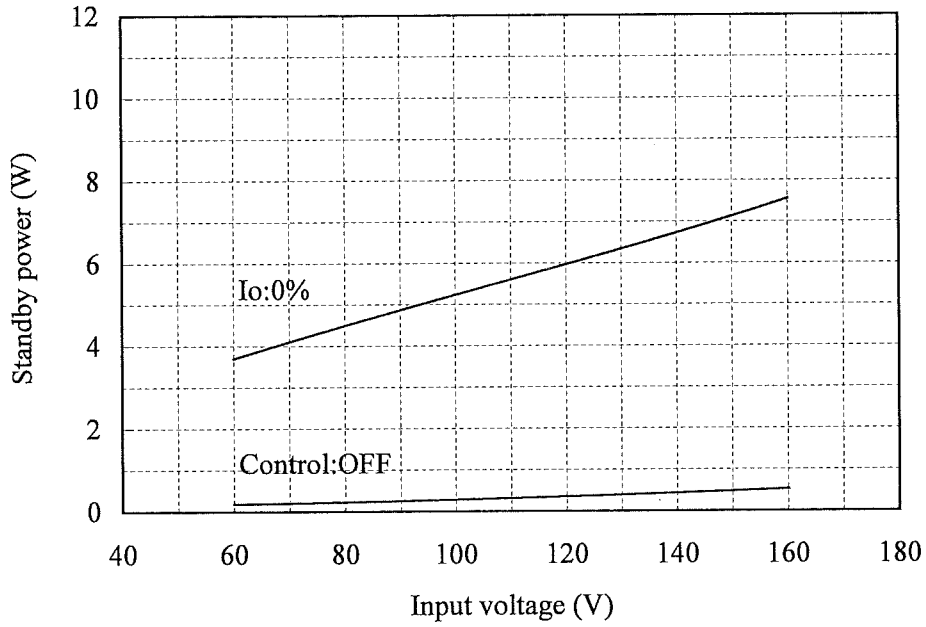

12V

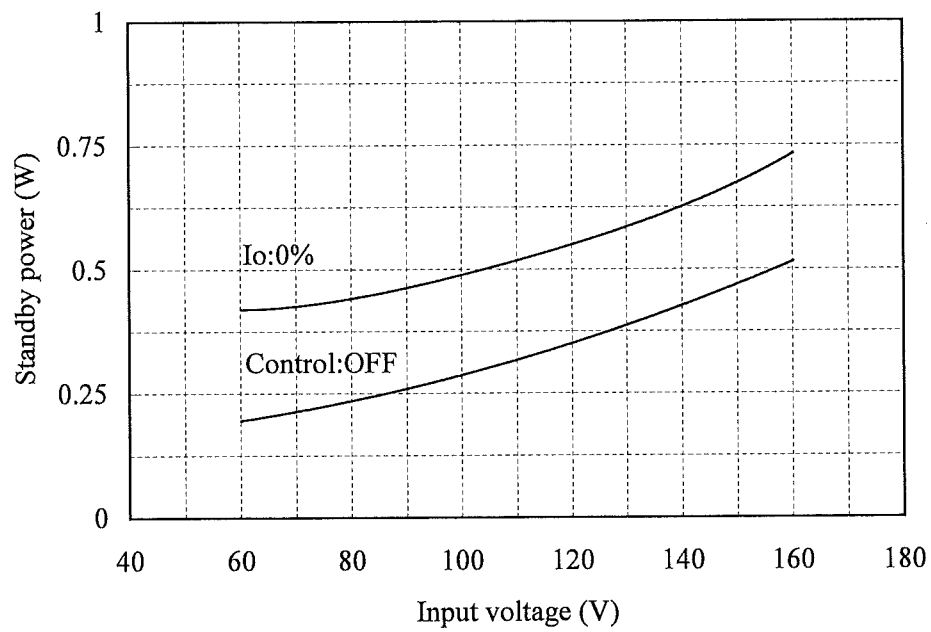

2.2 待機電力特性

Standby power characteristics

Condition Tbp : 25 °C

15V

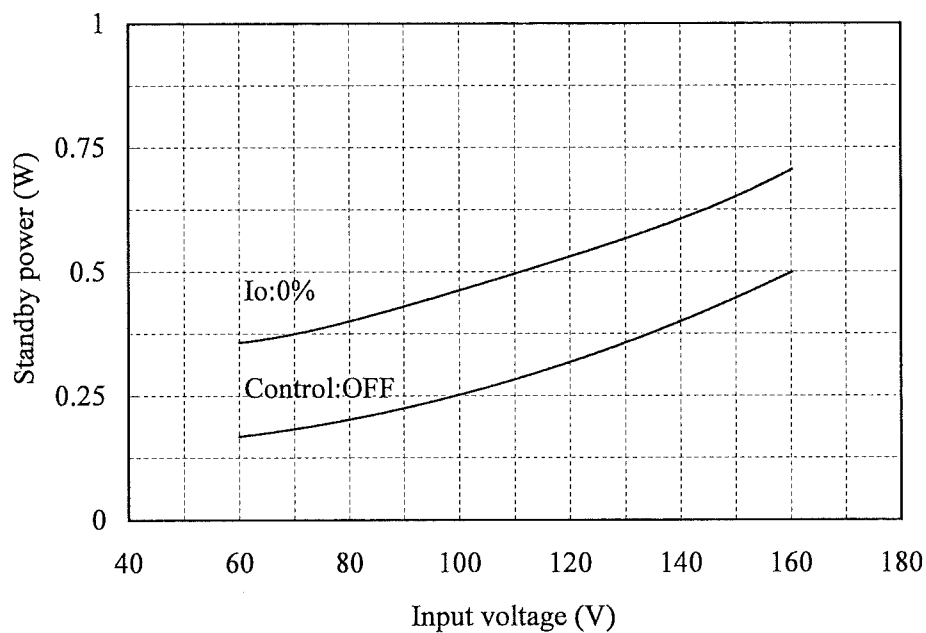

24V

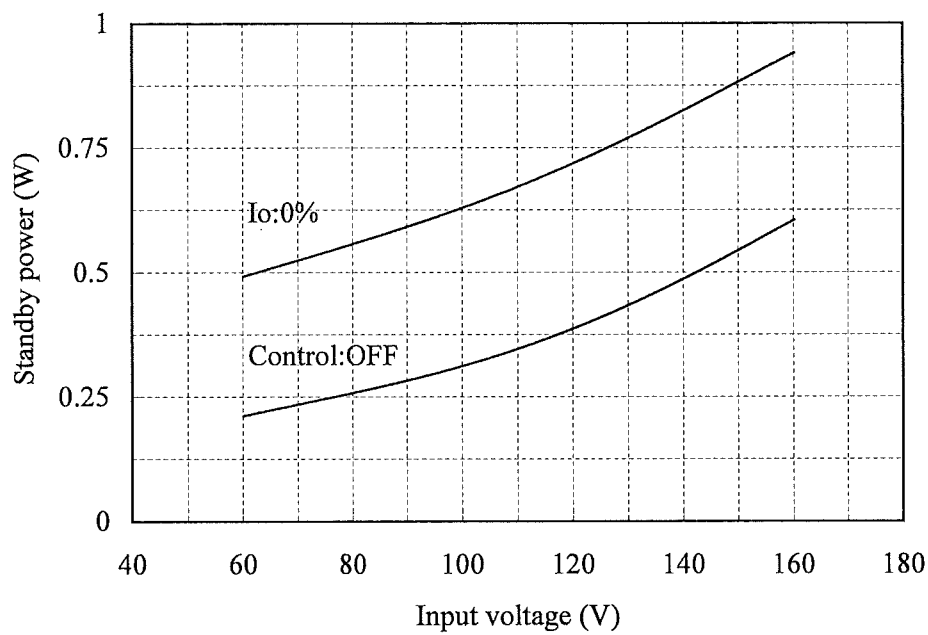

2.3 通電ドリフト特性

Warm up voltage drift characteristics

Conditions

V_{in} : 110 VDC

I_o : 100 %

T_a : 25 °C

5V

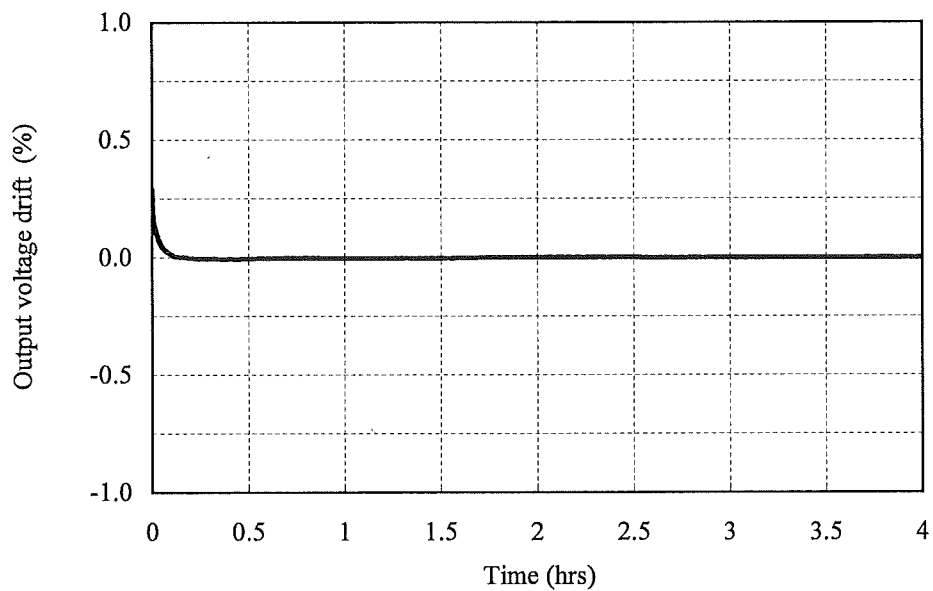

12V

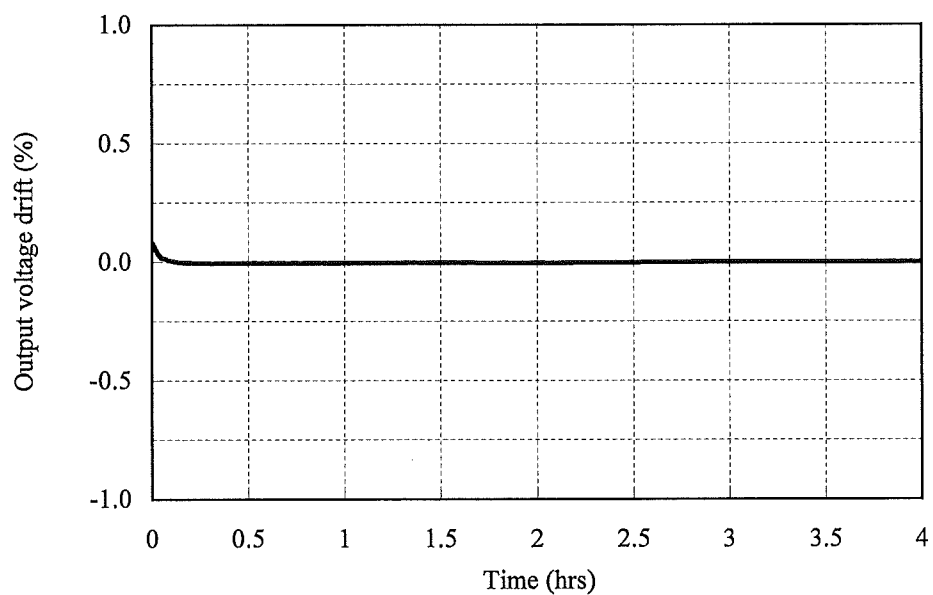

2.3 通電ドリフト特性

Warm up voltage drift characteristics

Conditions

Vin : 110 VDC

Io : 100 %

Ta : 25 °C

15V

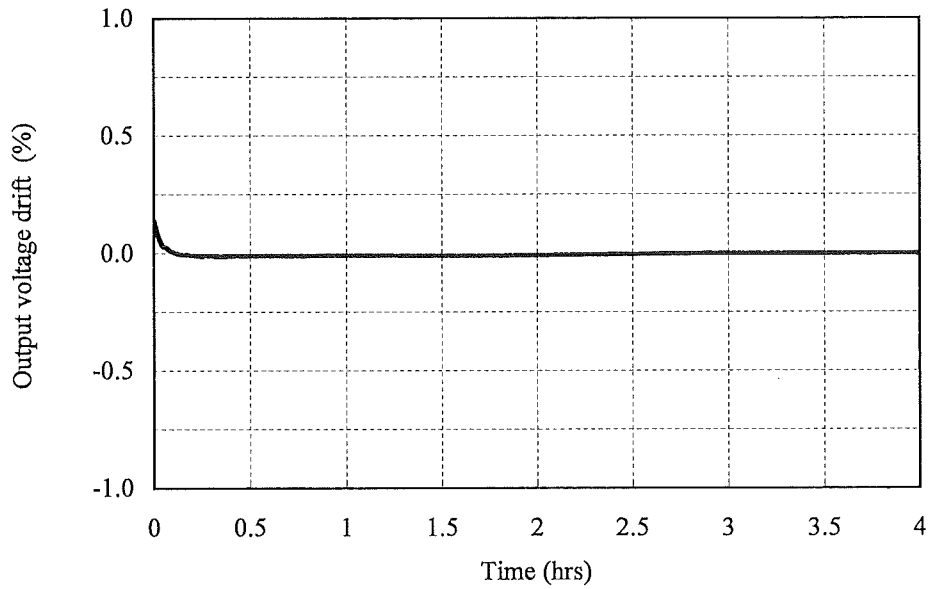

24V

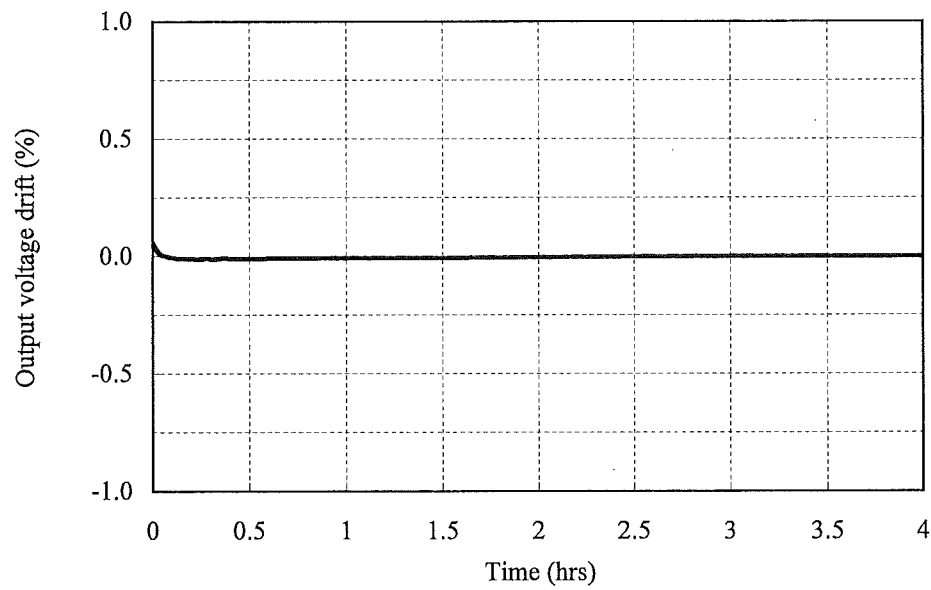

2.4 過電流保護特性

Over current protection (OCP) characteristics

入力電圧依存性

Input voltage dependence

Conditions Vin : 60 VDC -----
 : 110 VDC - - - - -
 : 160 VDC _____
 Tbp : 25 °C

ベースプレート温度依存性

Baseplate temperature dependence

Conditions Vin : 110 VDC
 Tbp : -40 °C -----
 : 25 °C - - - - -
 : 100 °C _____

5V

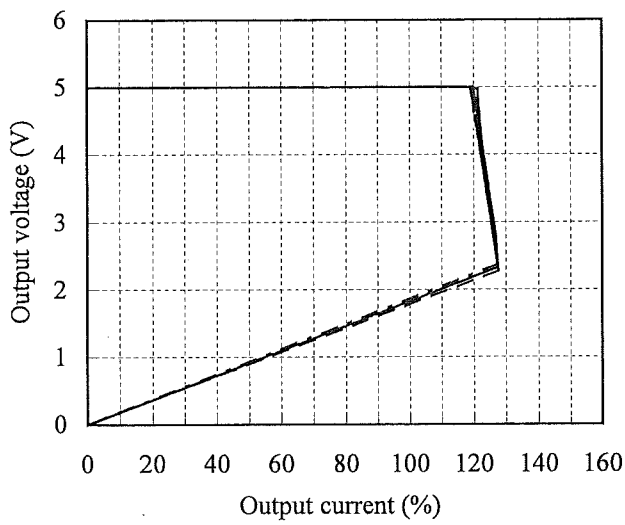

5V

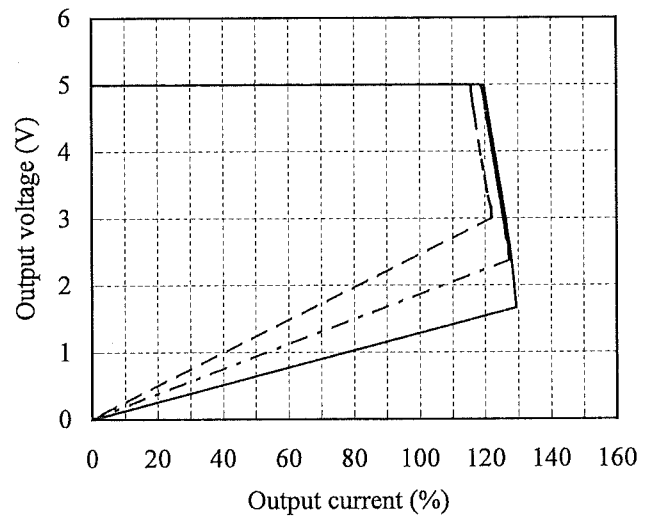

12V

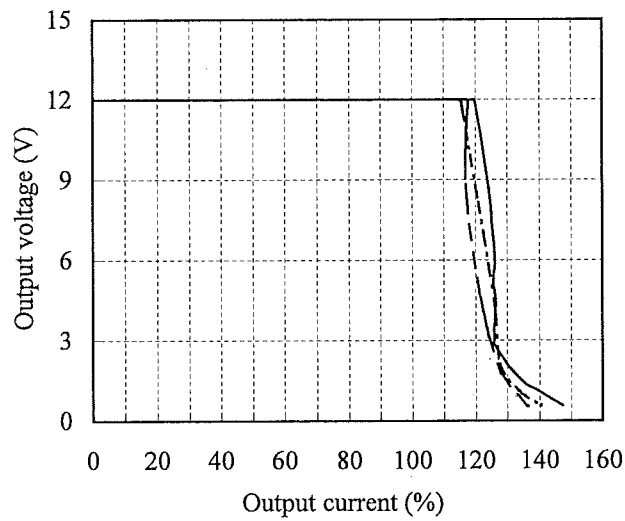

12V

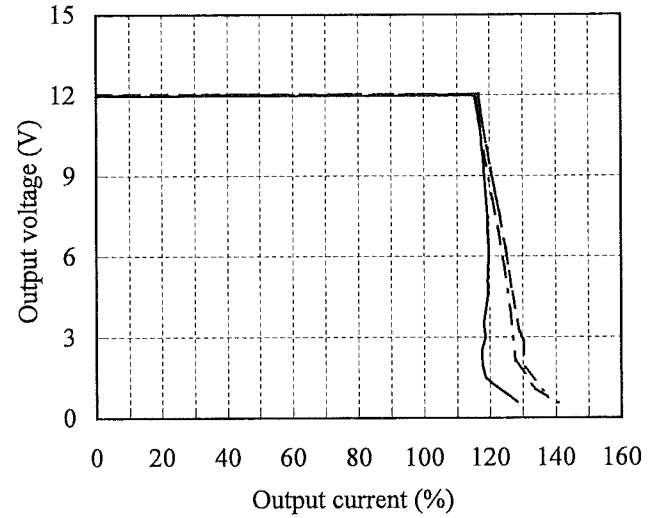

2.4 過電流保護特性

Over current protection (OCP) characteristics

入力電圧依存性

Input voltage dependence

Conditions Vin : 60 VDC -----
 : 110 VDC - - - - -
 : 160 VDC ————
 Tbp : 25 °C

ベースプレート温度依存性

Baseplate temperature dependence

Conditions Vin : 110 VDC
 Tbp : -40 °C -----
 : 25 °C - - - - -
 : 100 °C ————

15V

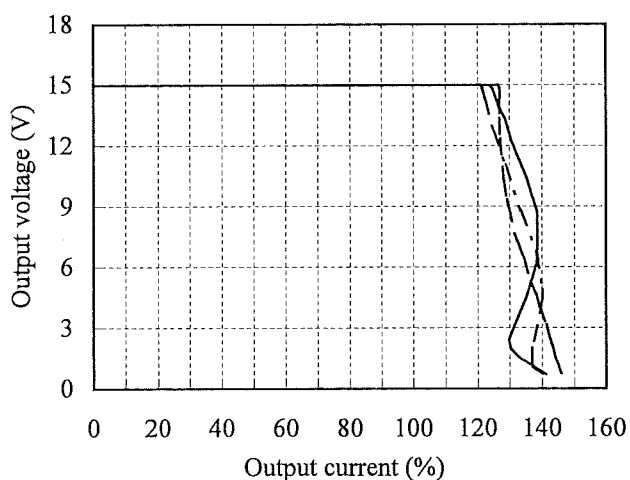

15V

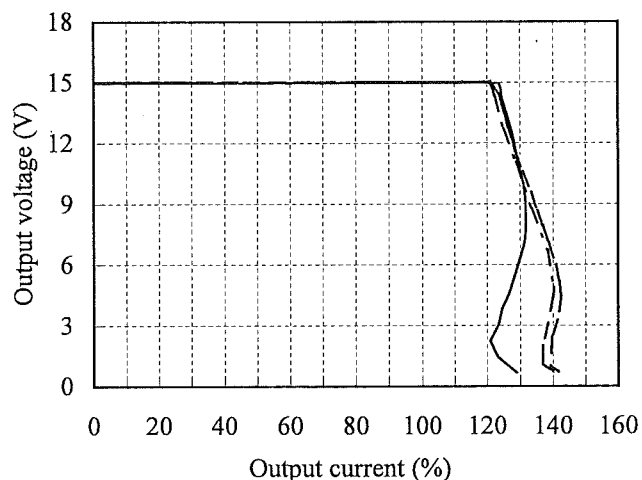

24V

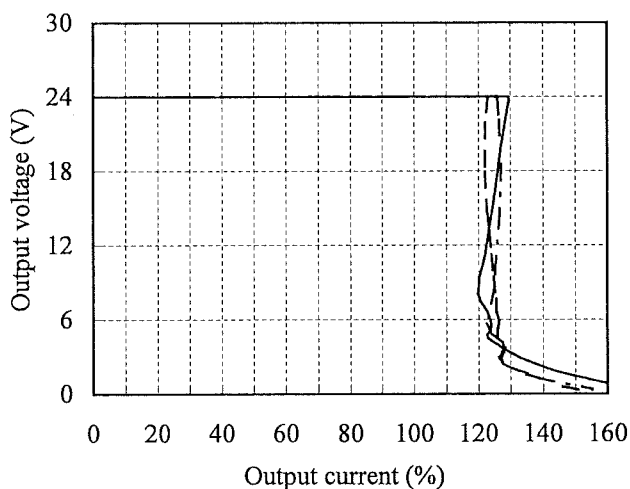

24V

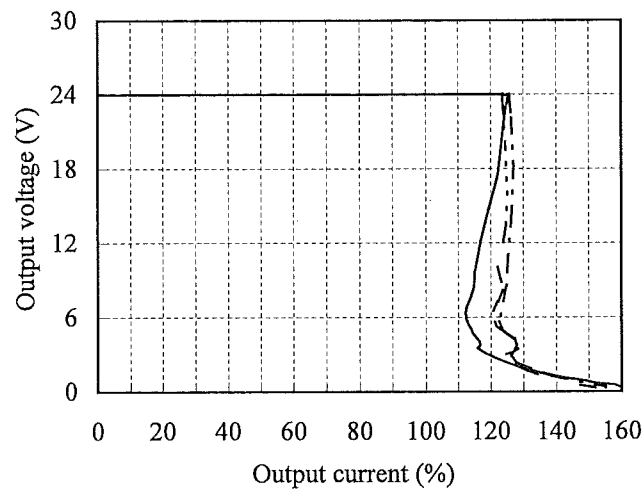

2.5 過電圧保護特性

Over voltage protection (OVP) characteristics

Conditions

Vin : 110 VDC

Io : 0 %

Tbp : 25 °C

5V

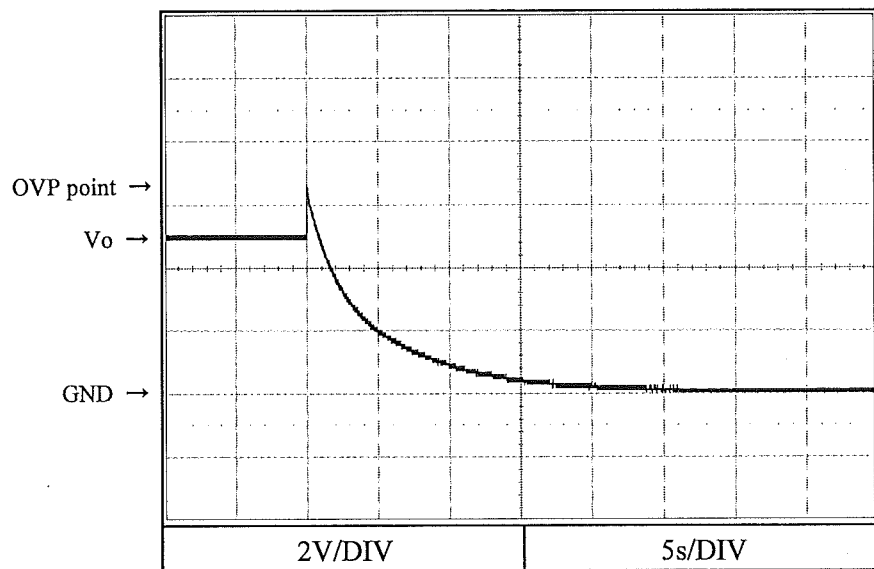

12V

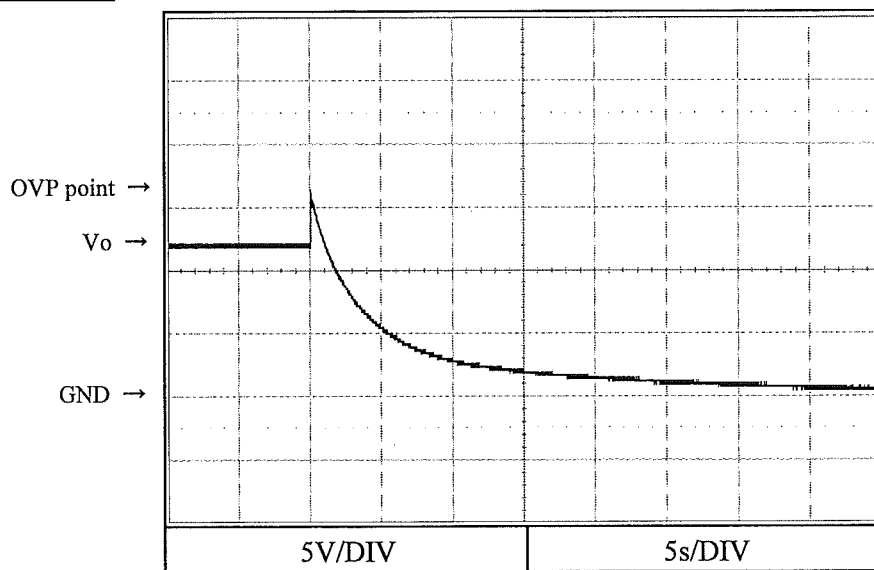

2.5 過電圧保護特性

Over voltage protection (OVP) characteristics

Conditions

Vin : 110 VDC

Io : 0 %

Tbp : 25 °C

15V

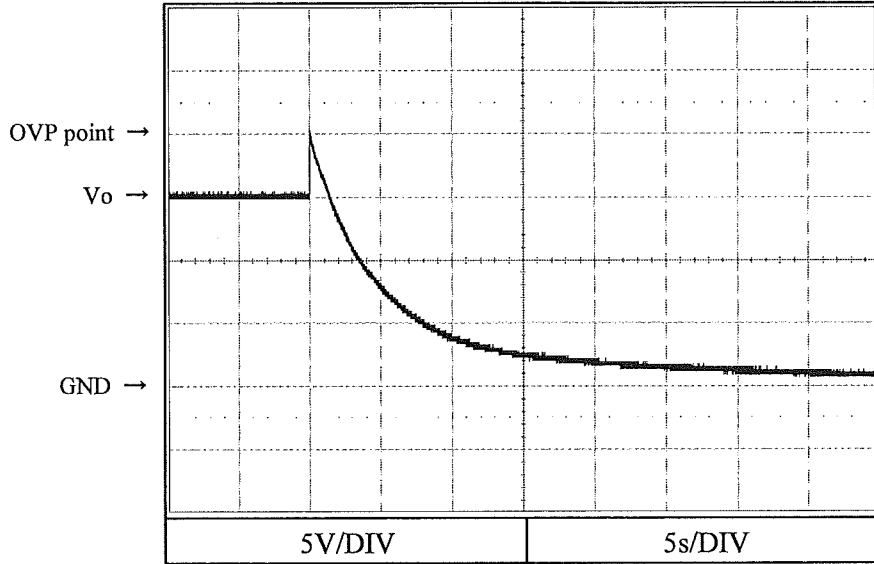

24V

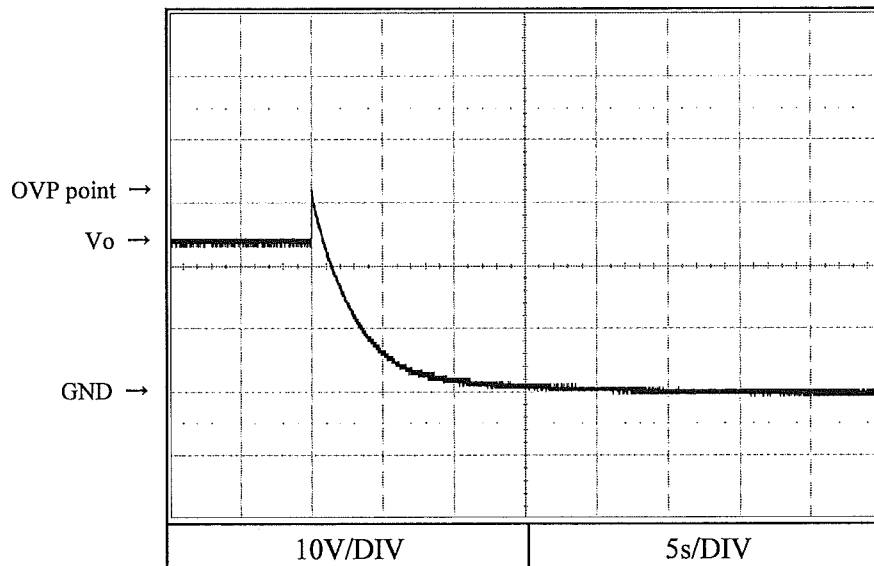

2.6 出力立ち上がり、立ち下がり特性
Output rise and fall characteristics

Conditions Vin : 110 VDC
Io : 0 %
Tbp : 25 °C

5V

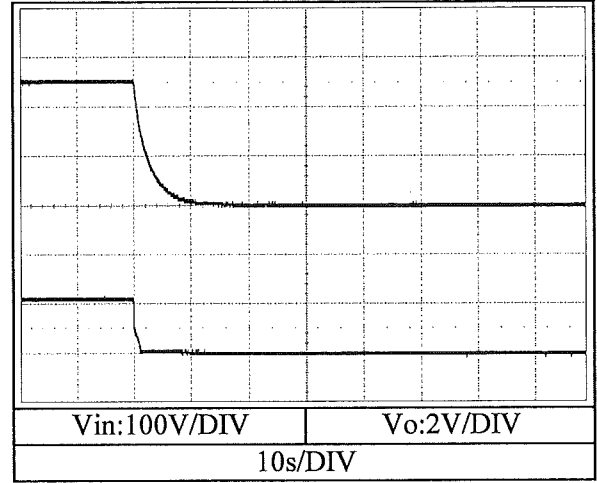
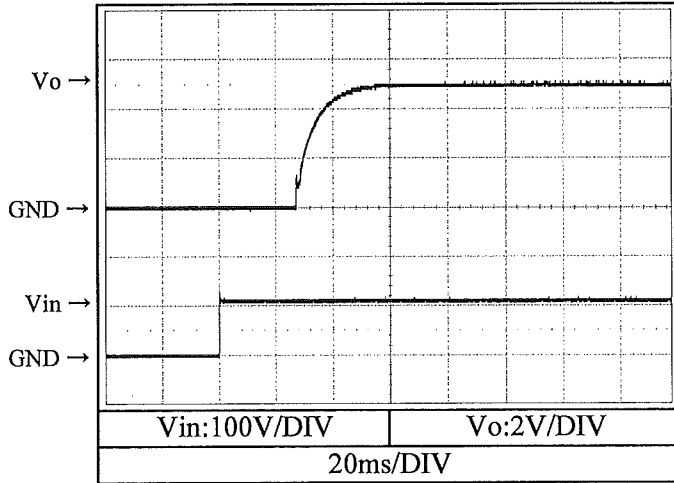

12V

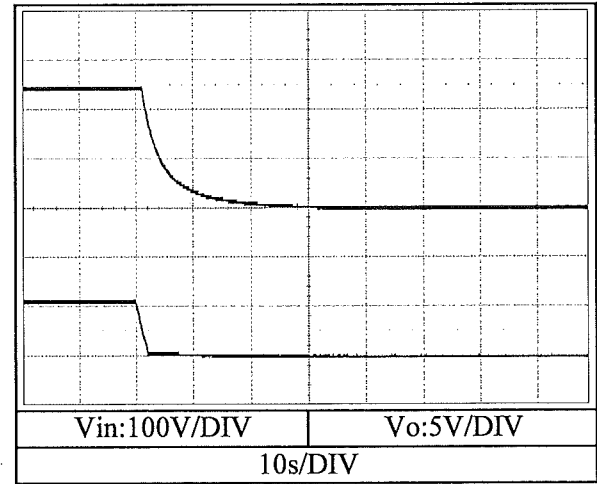
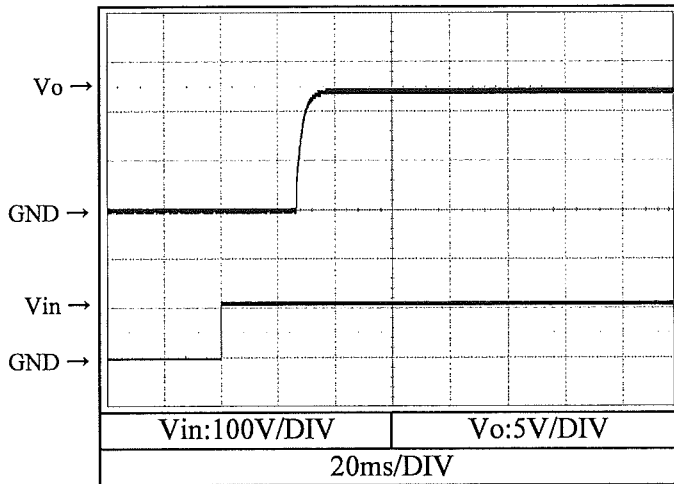

2.6 出力立ち上がり、立ち下がり特性
Output rise and fall characteristics

Conditions Vin : 110 VDC
Io : 0 %
Tbp : 25 °C

15V

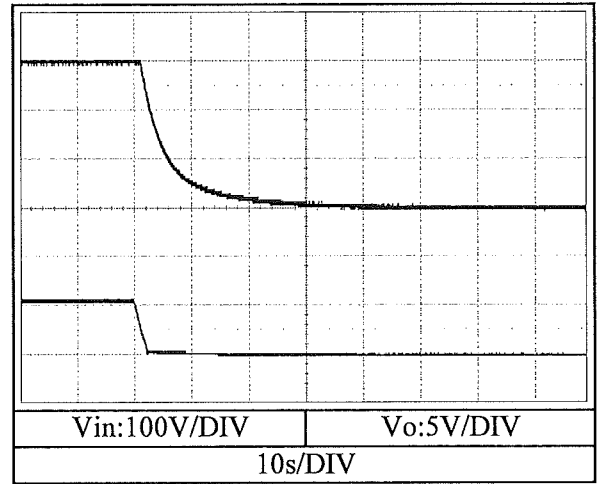
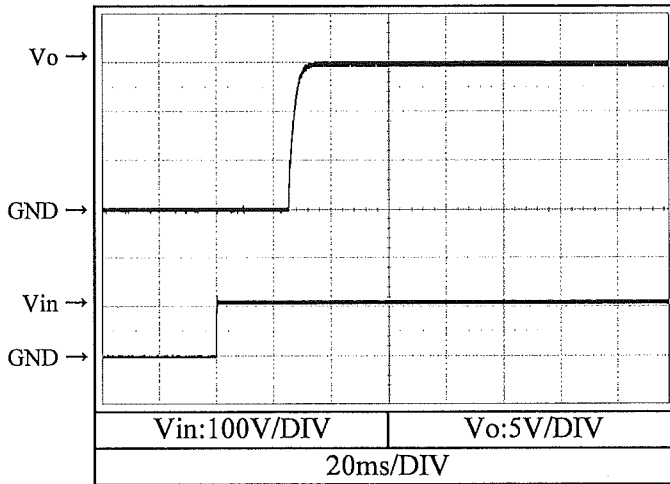

24V

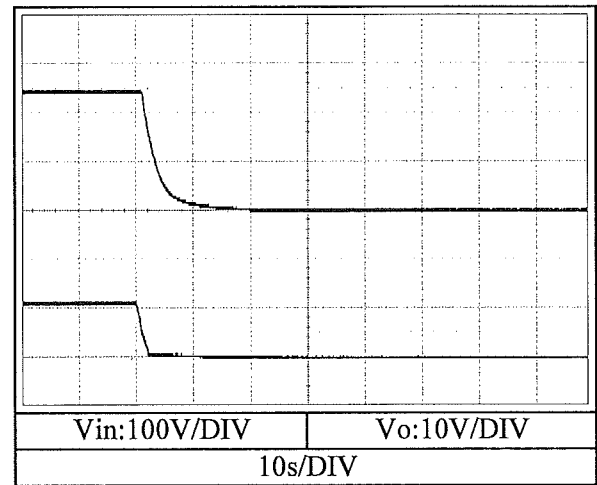
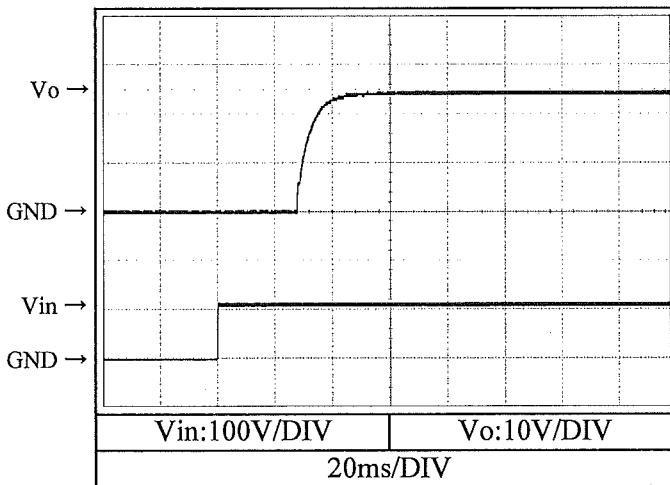

2.6 出力立ち上がり、立ち下がり特性
Output rise and fall characteristics

Conditions Vin : 110 VDC
Io : 100 %
Tbp : 25 °C

5V

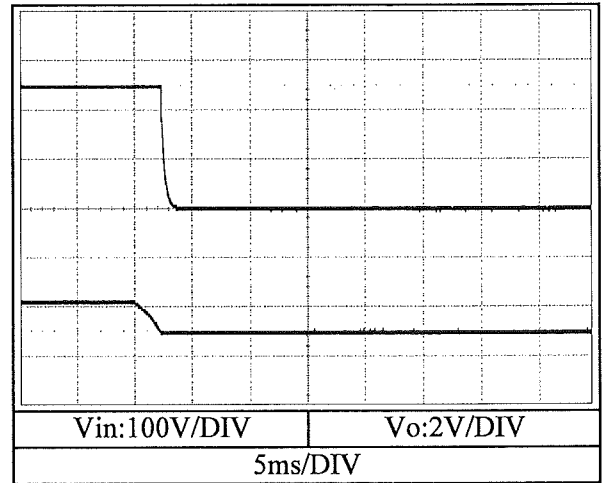
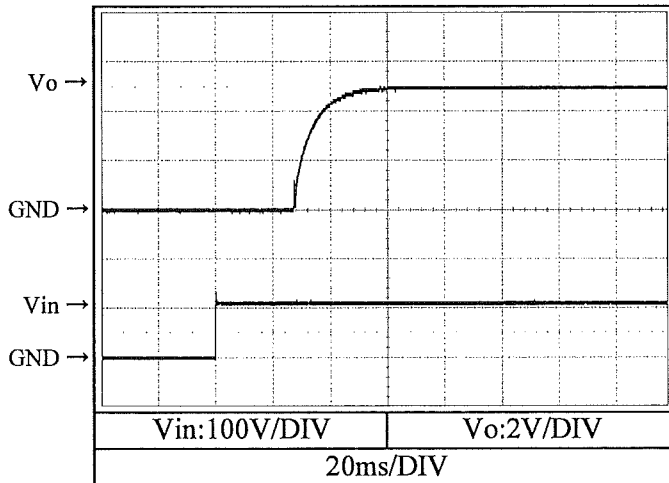

12V

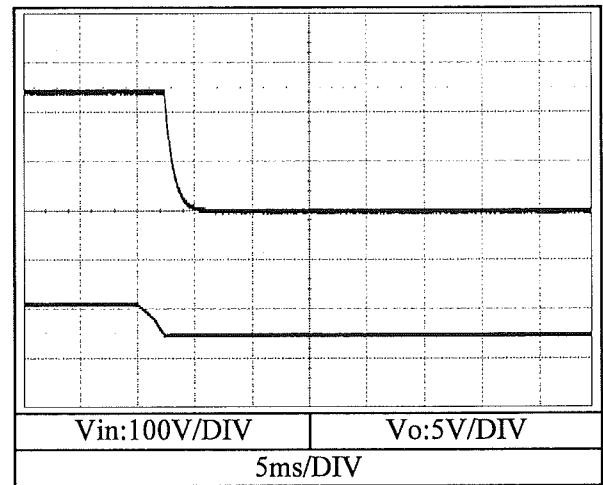
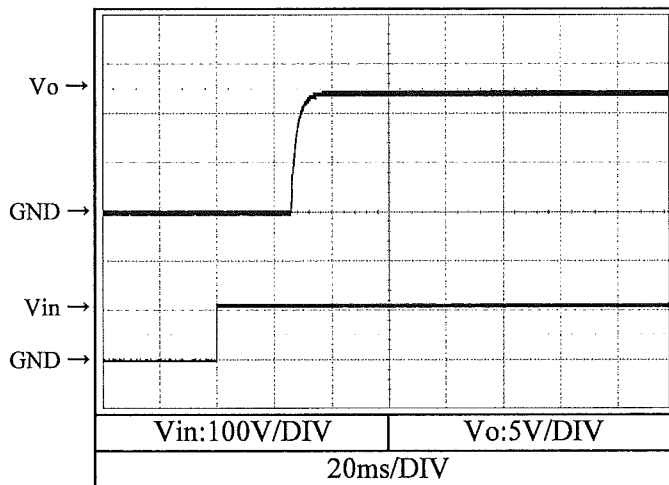

2.6 出力立ち上がり、立ち下がり特性
Output rise and fall characteristics

Conditions Vin : 110 VDC
Io : 100 %
Tbp : 25 °C

15V

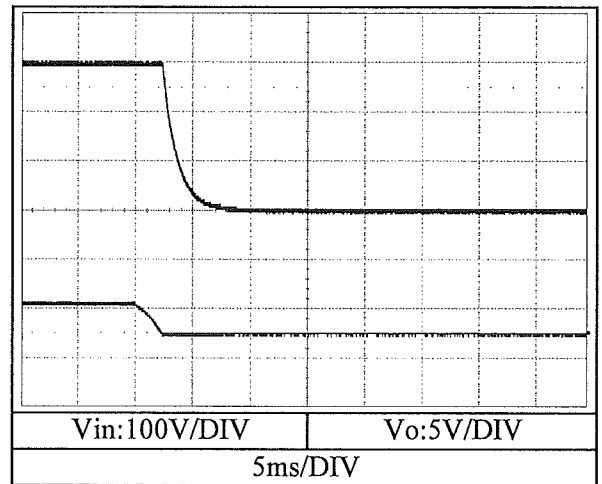
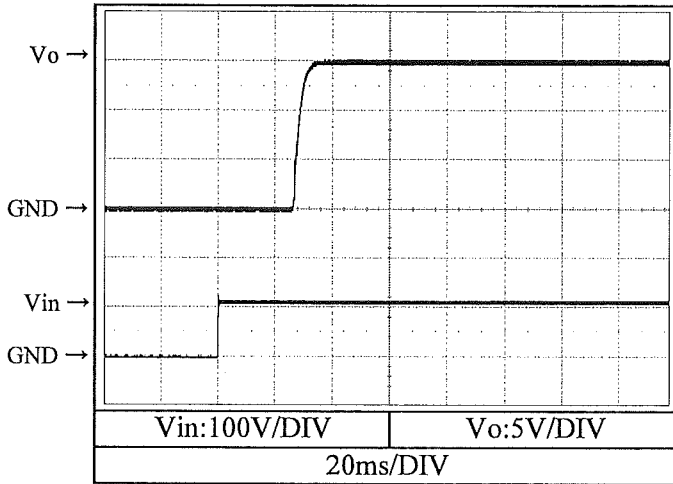

24V

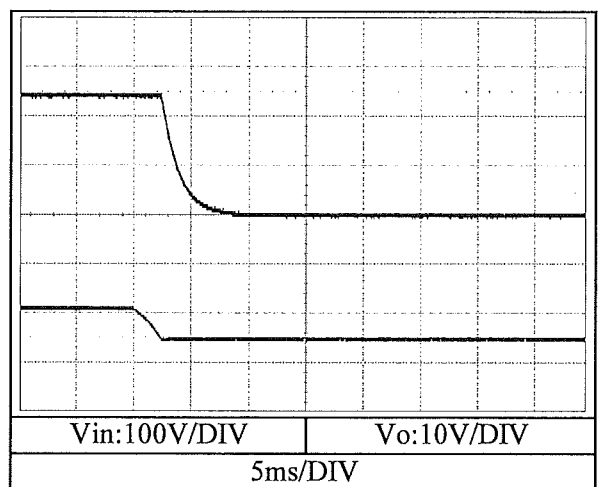
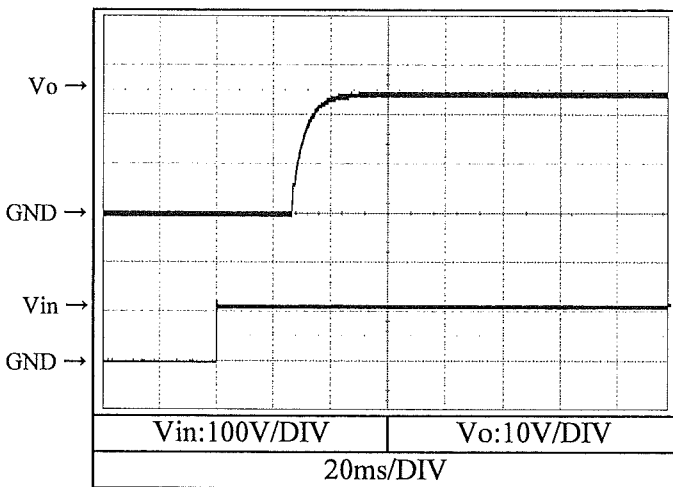

2.6 出力立ち上がり、立ち下がり特性 (ON/OFFコントロール時)

Output rise and fall characteristics with ON/OFF CONTROL

Conditions

Vin : 110 VDC

Io : 0%

Tbp : 25 °C

5V

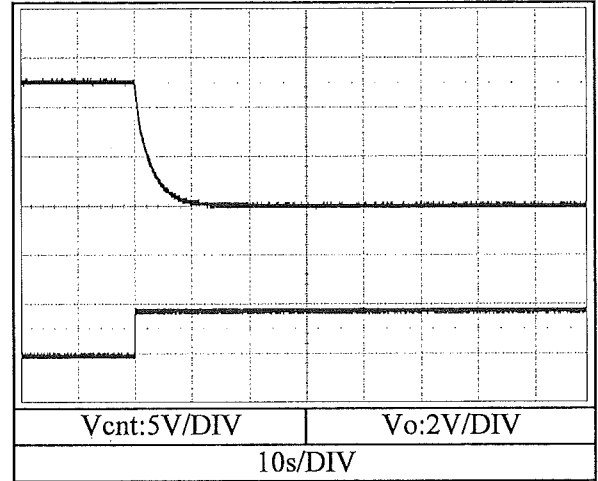
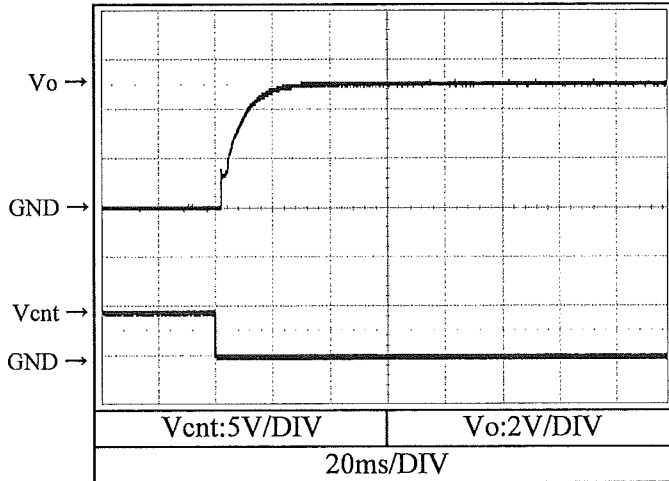

12V

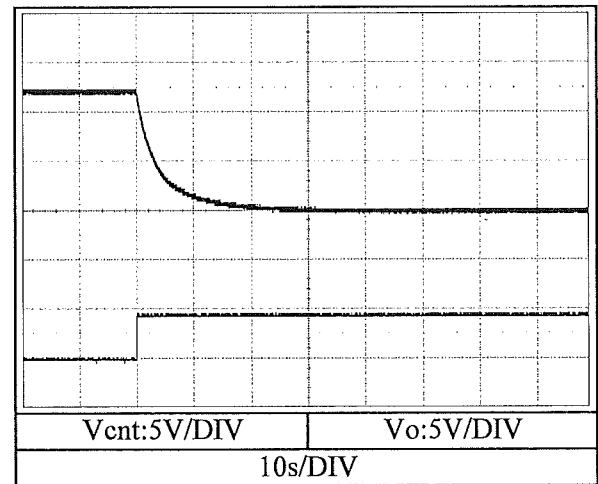
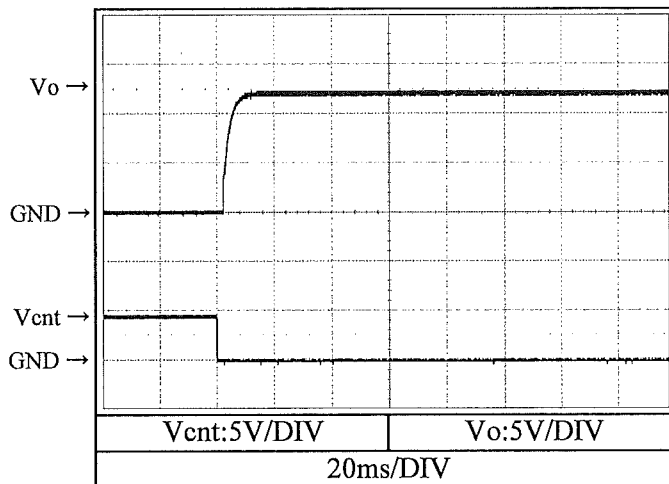

2.6 出力立ち上がり、立ち下がり特性 (ON/OFFコントロール時)

Output rise and fall characteristics with ON/OFF CONTROL

Conditions

Vin : 110 VDC

Io : 0%

Tbp : 25 °C

15V

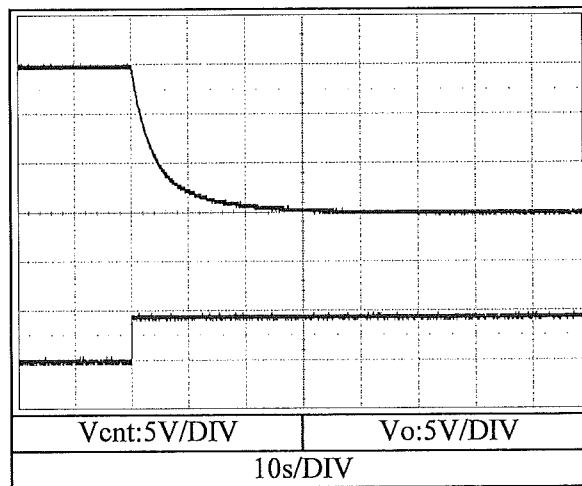
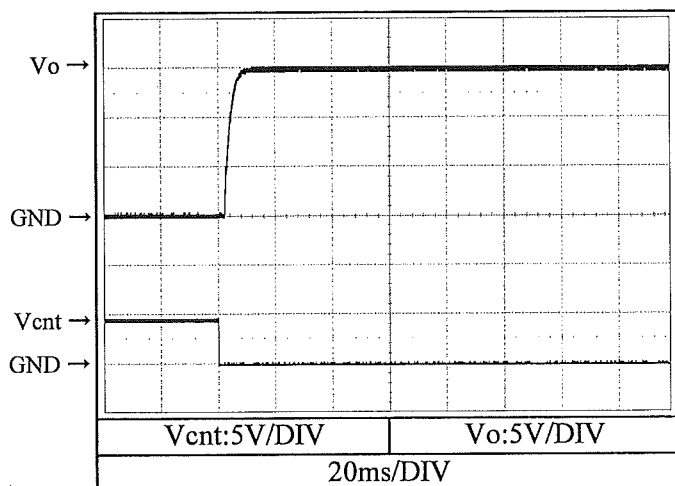

24V

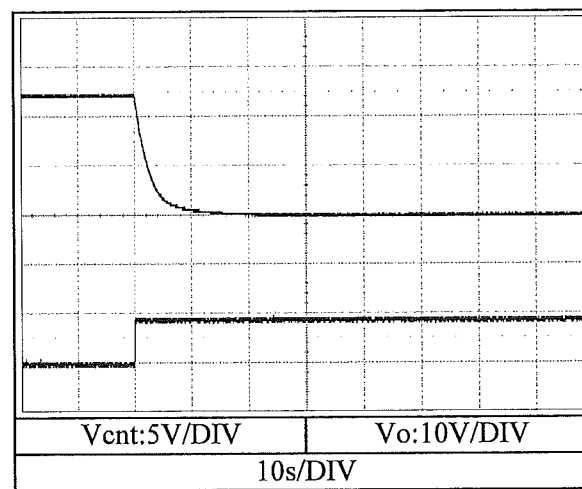
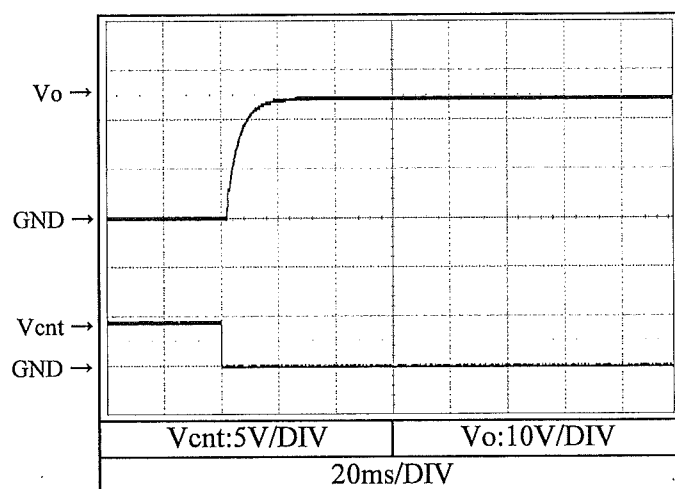

2.6 出力立ち上がり、立ち下がり特性 (ON/OFFコントロール時)

Output rise and fall characteristics with ON/OFF CONTROL

Conditions

Vin : 110 VDC

Io : 100 %

Tbp : 25 °C

5V

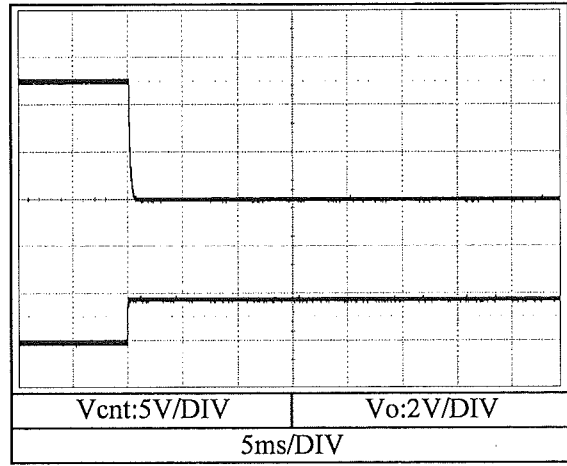
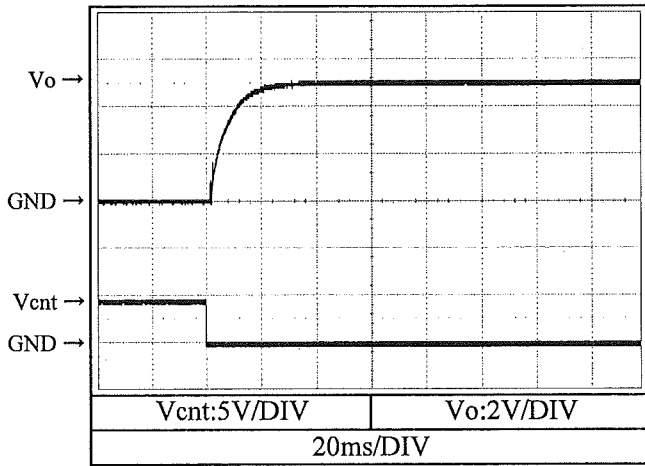

12V

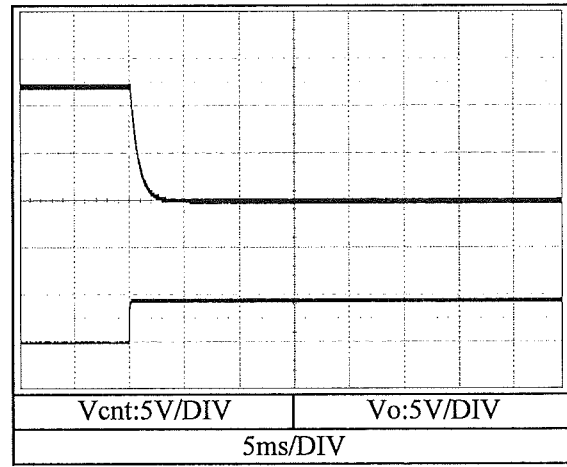
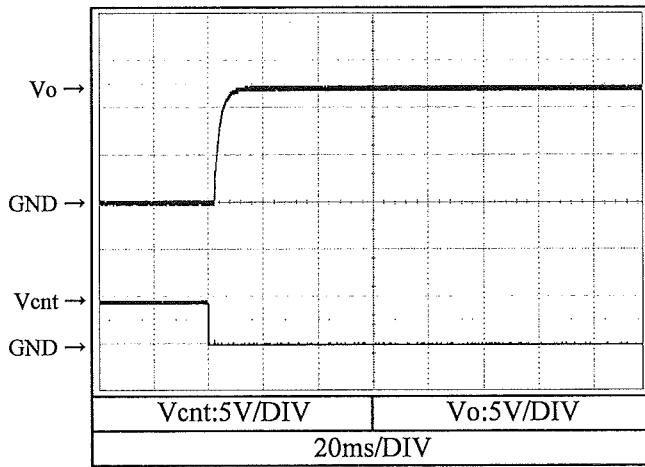

2.6 出力立ち上がり、立ち下がり特性 (ON/OFFコントロール時)

Output rise and fall characteristics with ON/OFF CONTROL

Conditions

Vin : 110 VDC

Io : 100 %

Tbp : 25 °C

15V

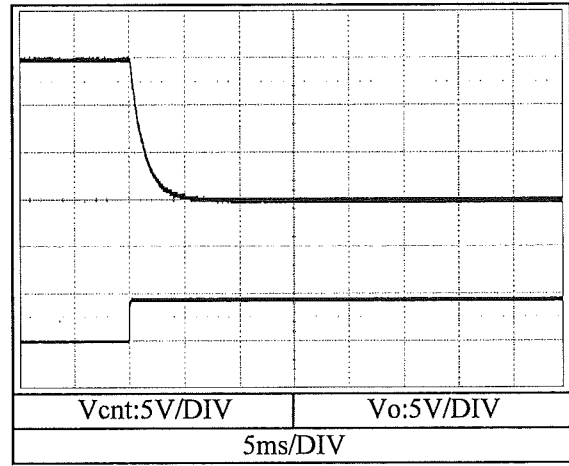
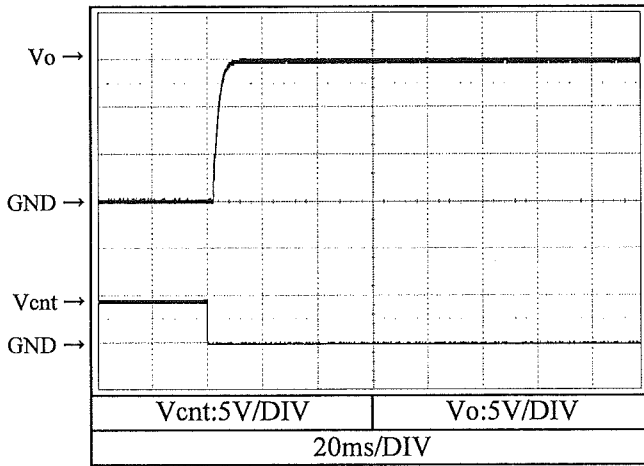

24V

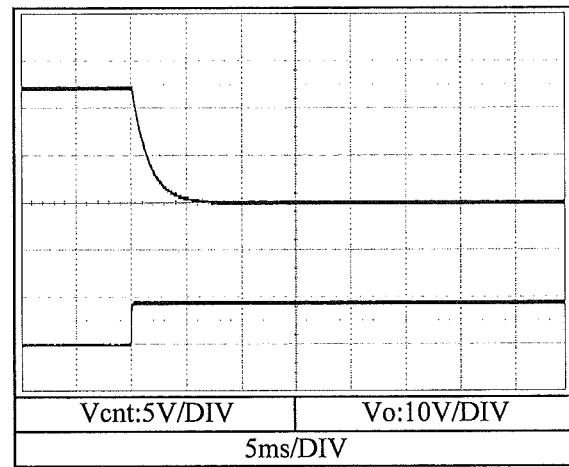
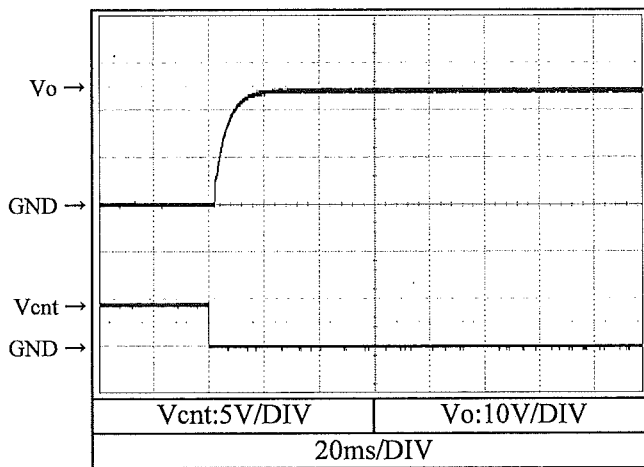

2.7 過渡応答（負荷急変）特性
Dynamic load response characteristics

Conditions Vin : 110 VDC
Tbp : 25 °C

5V

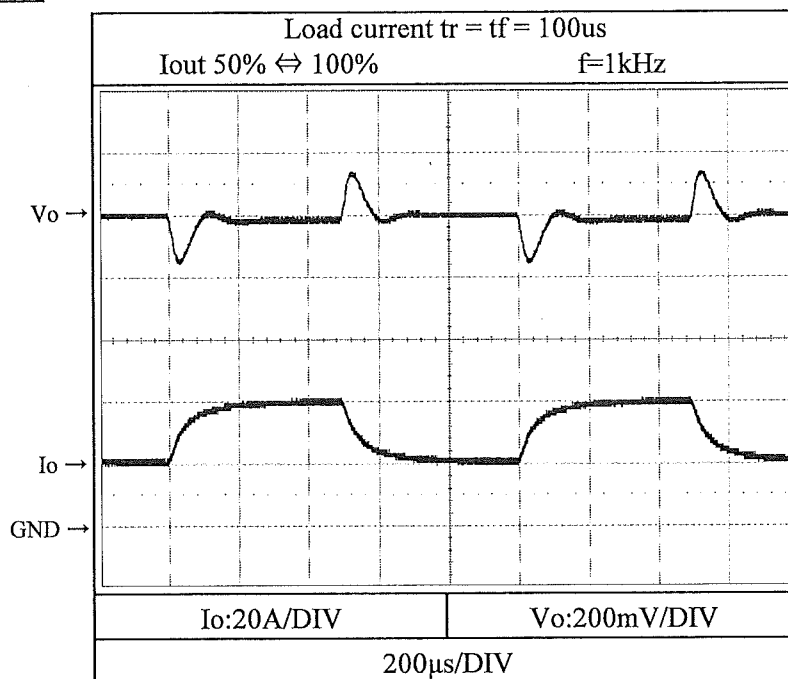

12V

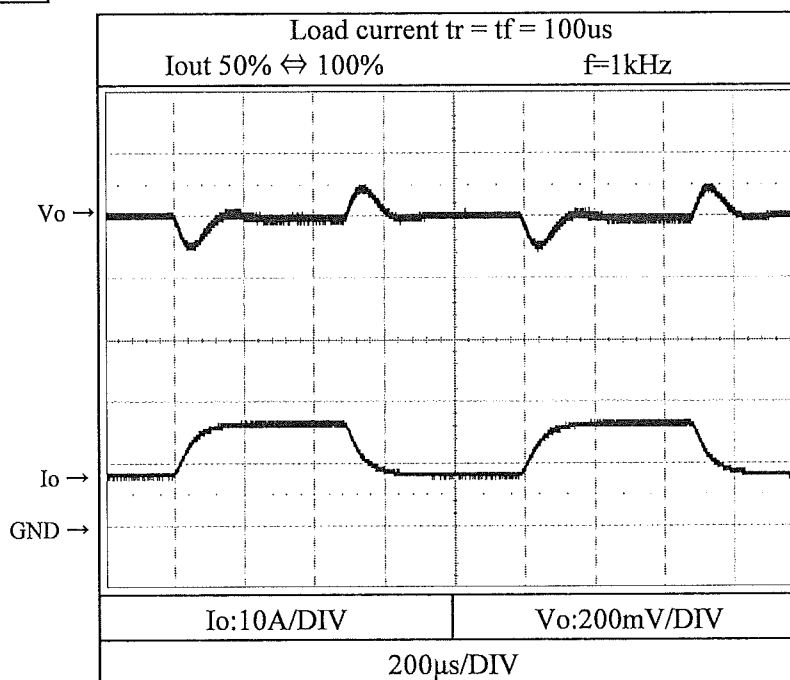

2.7 過渡応答（負荷急変）特性
Dynamic load response characteristics

Conditions Vin : 110 VDC
Tbp : 25 °C

15V

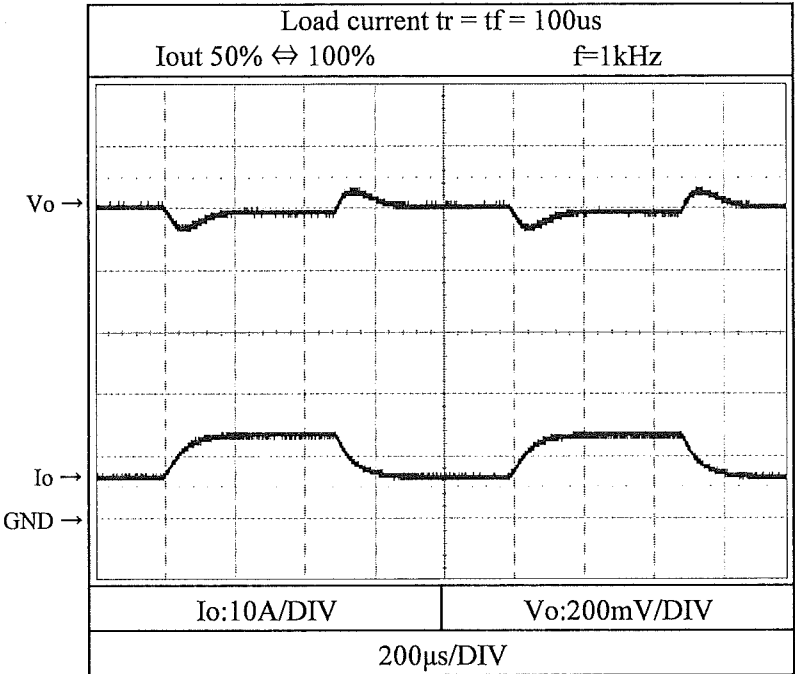

24V

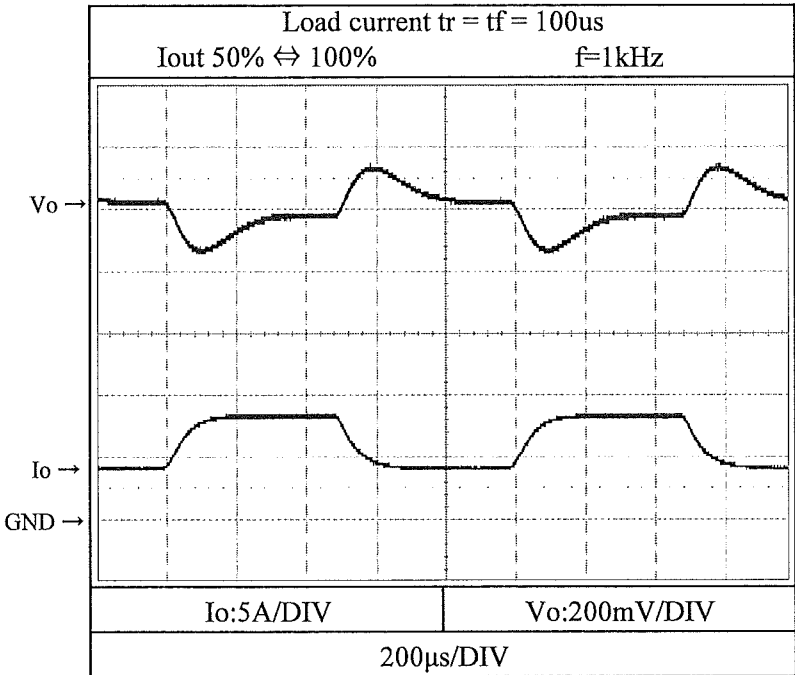

2.8 入力サージ電流（突入電流）特性
Inrush current characteristics

Conditions

V_{in} : 110 VDC
I_o : 100 %
T_{bp} : 25 °C

5V

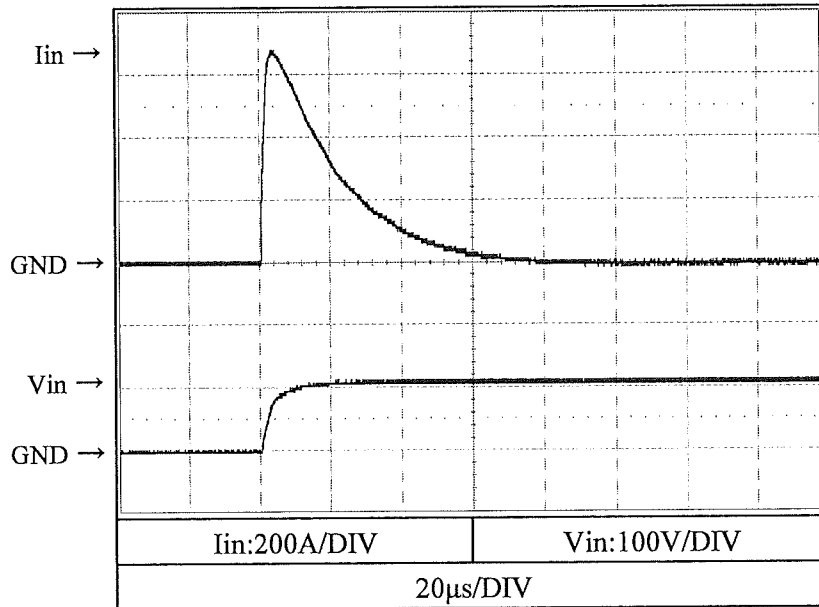

2.9 出力リップル、ノイズ波形
Output ripple and noise waveform

Conditions

Vin : 110 VDC

Io : 100 %

Tbp : 25 °C

5V

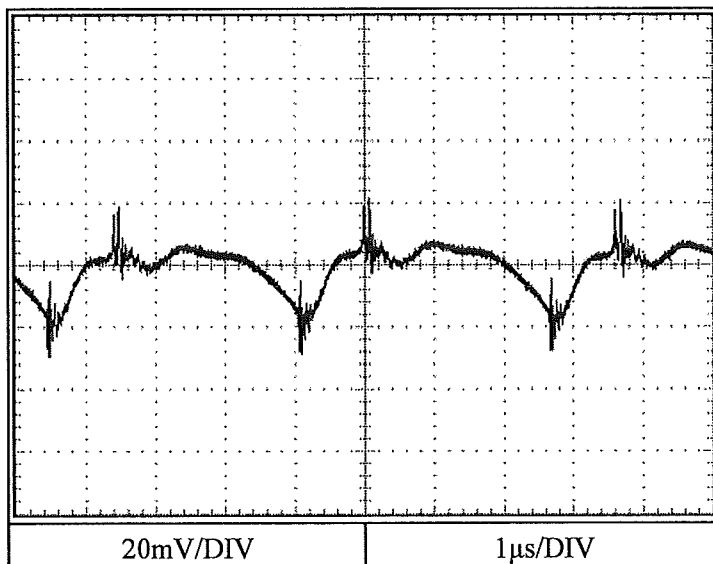

12V

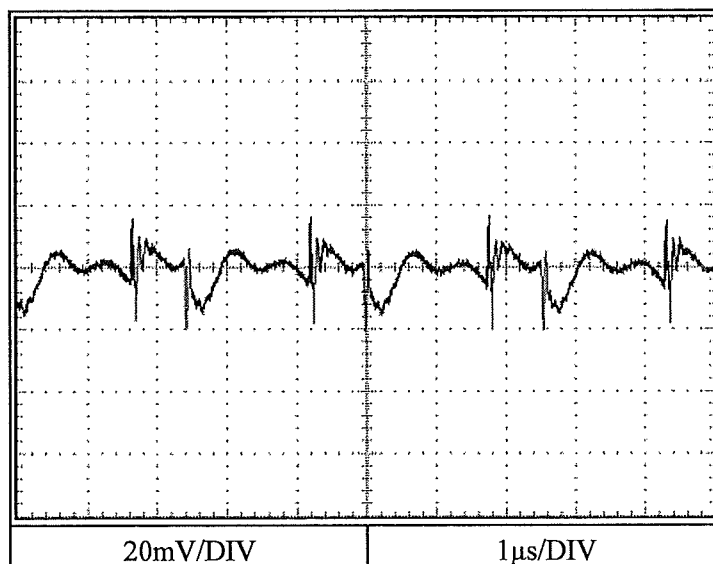

2.9 出力リップル、ノイズ波形
Output ripple and noise waveform

Conditions

Vin : 110 VDC

Io : 100 %

Tbp : 25 °C

15V

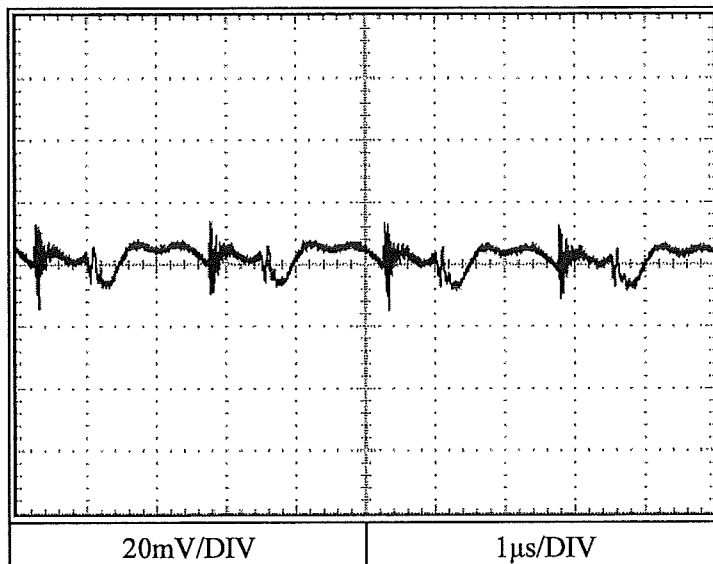

24V

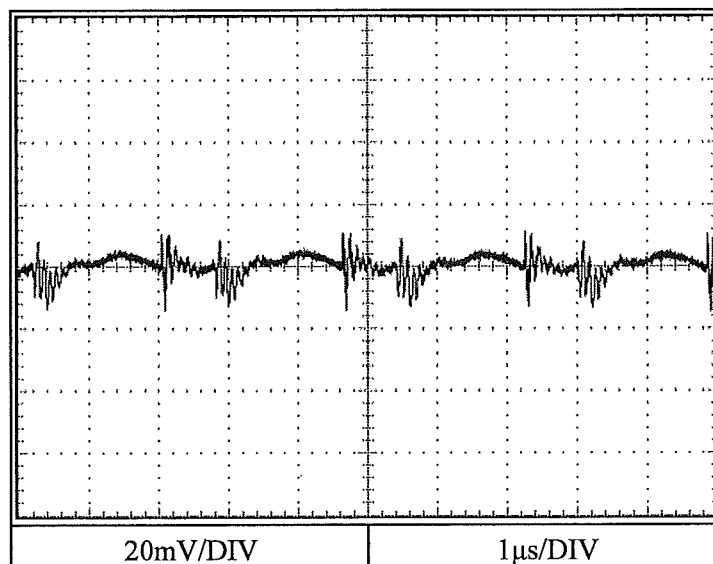

2.10 EMI特性

Electro-Magnetic Interference characteristics

(a) 雑音端子電圧 (帰還ノイズ)

Conducted Emission

Conditions

Vin : 110 VDC

Io : 100 %

Tbp : 25 °C

5V

+Vin

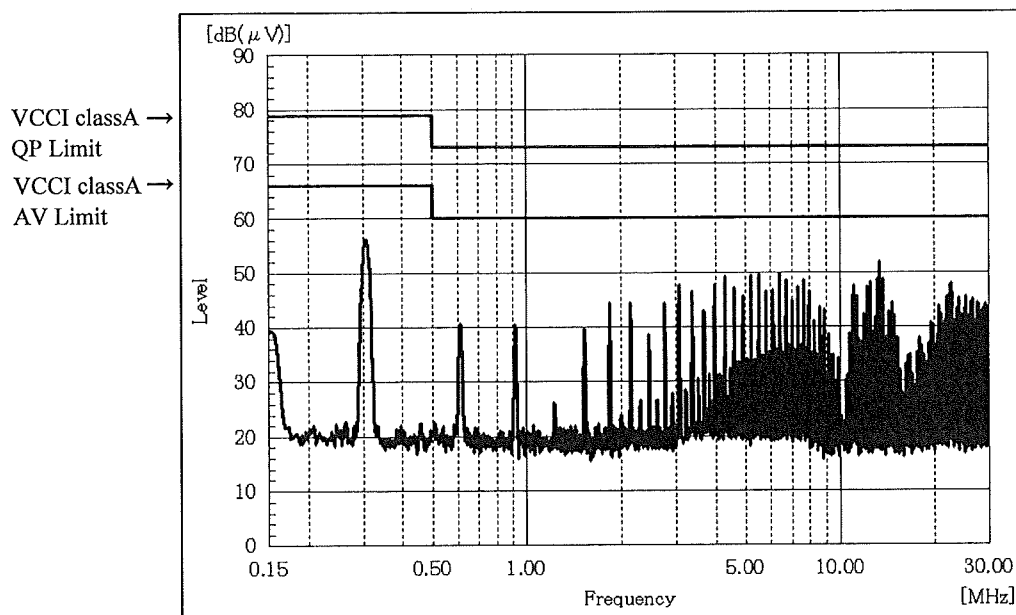

-Vin

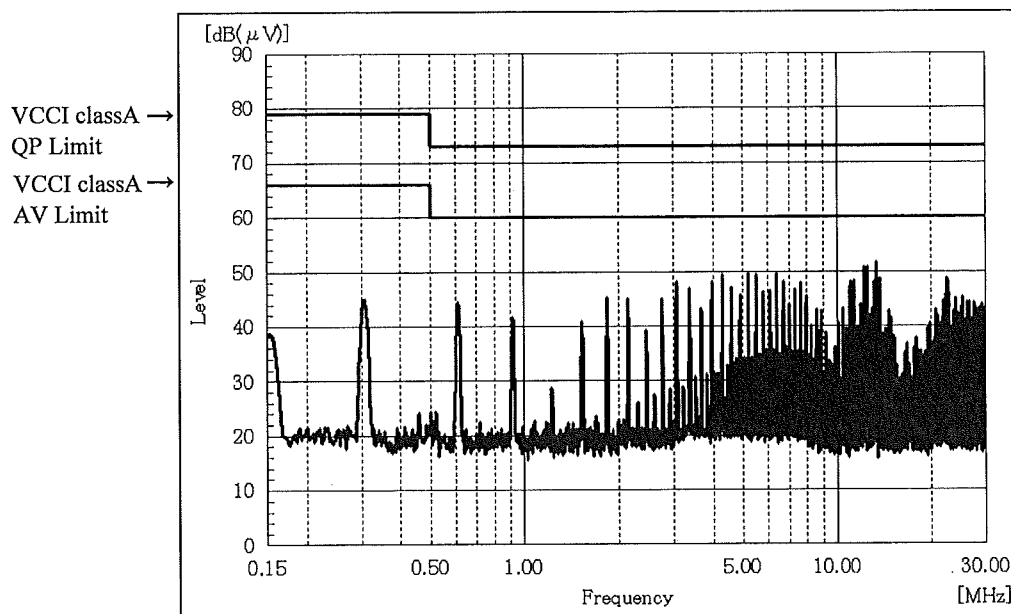

2.10 EMI特性

Electro-Magnetic Interference characteristics

(a) 雑音端子電圧 (帰還ノイズ)

Conducted Emission

Conditions

Vin : 110 VDC

Io : 100 %

Tbp : 25 °C

12V

+Vin

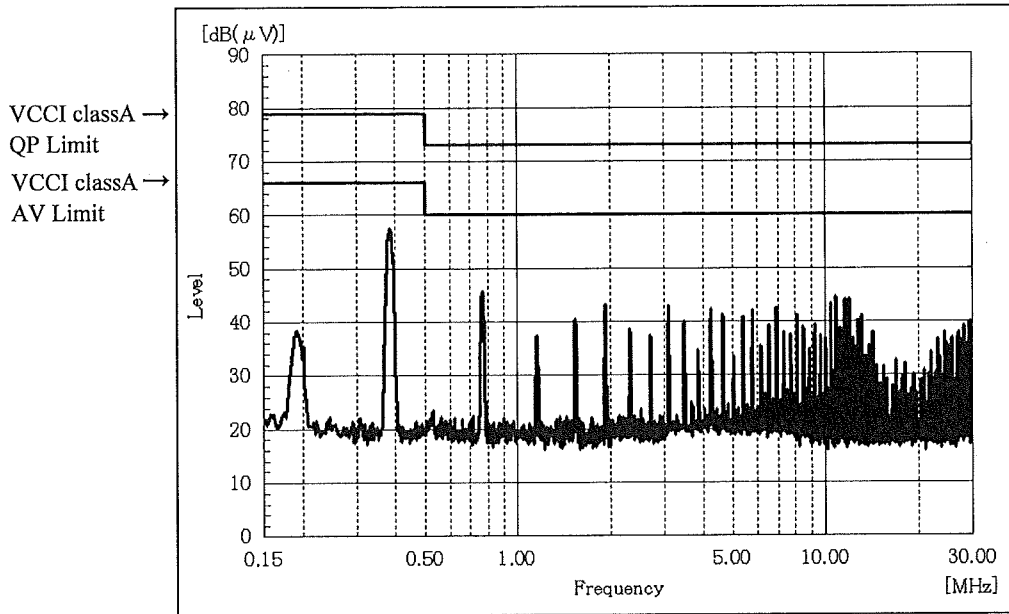

-Vin

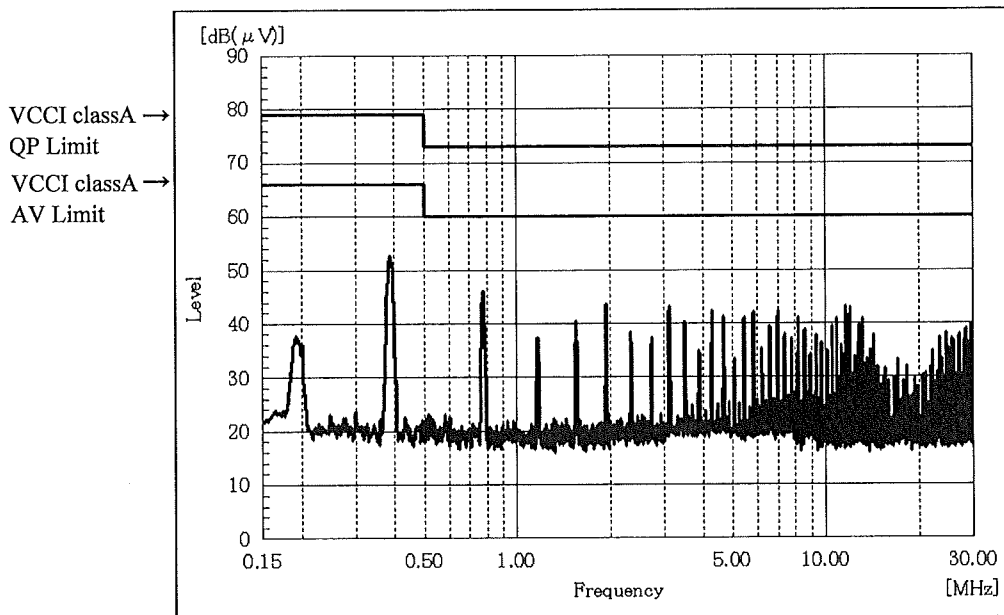

2.10 EMI特性

Electro-Magnetic Interference characteristics

(a) 雑音端子電圧 (帰還ノイズ)

Conducted Emission

Conditions

Vin : 110 VDC

Io : 100 %

Tbp : 25 °C

15V

+Vin

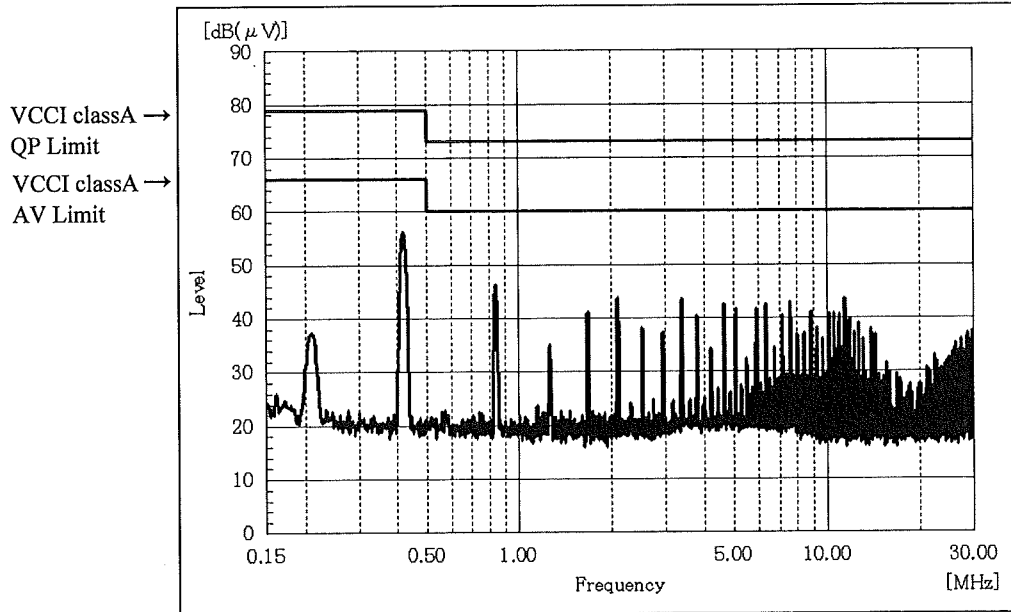

-Vin

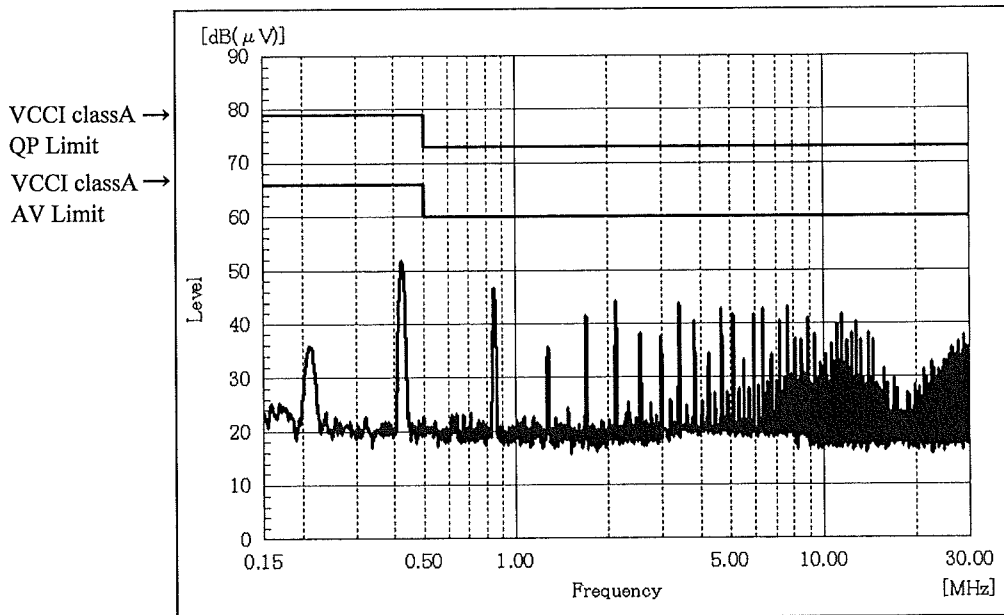

2.10 EMI特性

Electro-Magnetic Interference characteristics

(a) 雑音端子電圧 (帰還ノイズ)

Conducted Emission

Conditions

Vin : 110 VDC

Io : 100 %

Tbp : 25 °C

24V

+Vin

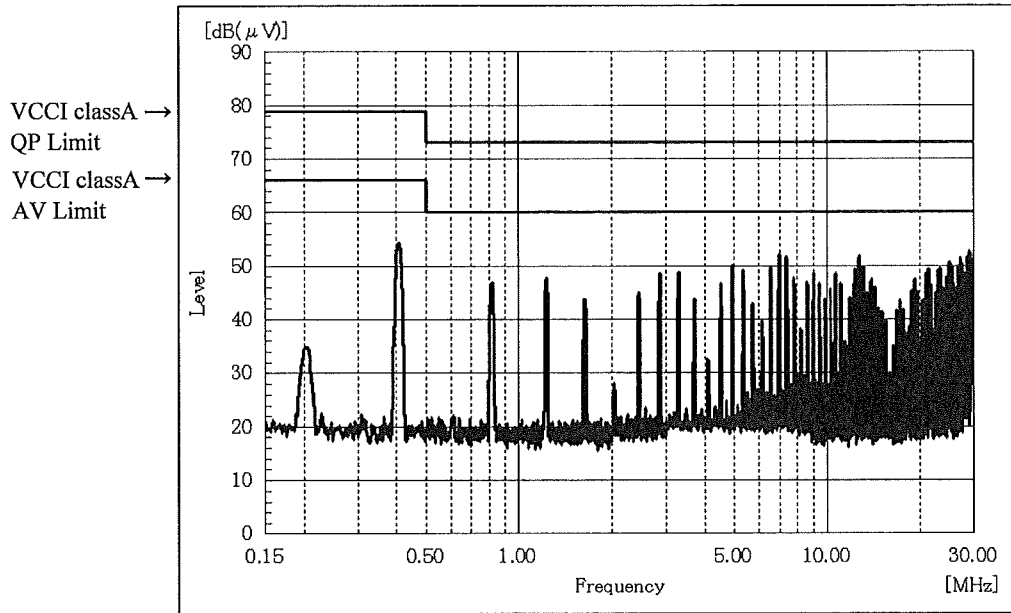

-Vin

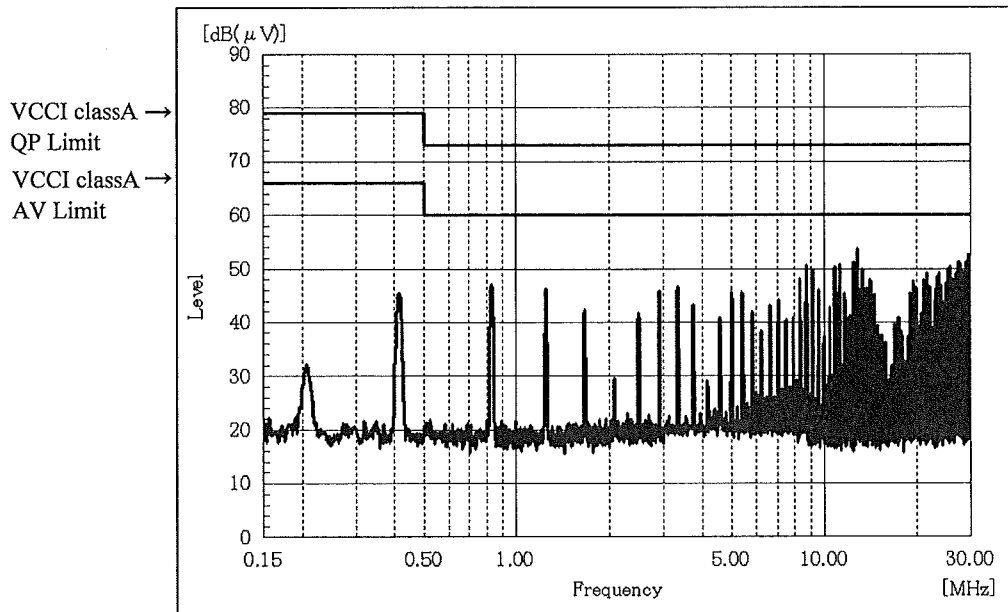

2.10 EMI特性

Electro-Magnetic Interference characteristics

(b) 雑音電界強度 (輻射ノイズ)

Radiated Emission

Conditions

Vin : 110 VDC

Io : 100 %

Tbp : 25 °C

5V

HORIZONTAL

VCCI classA →
QP Limit

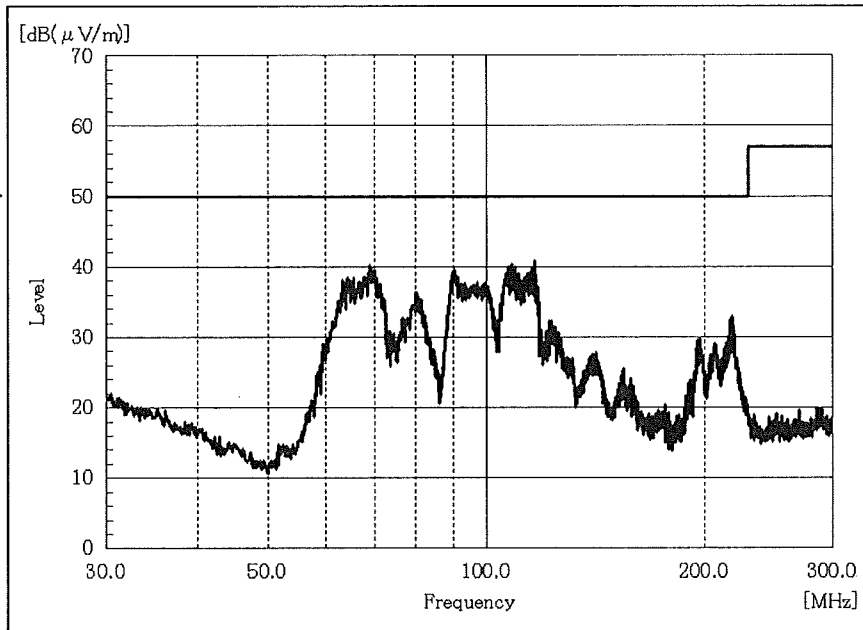

VERTICAL

VCCI classA →
QP Limit

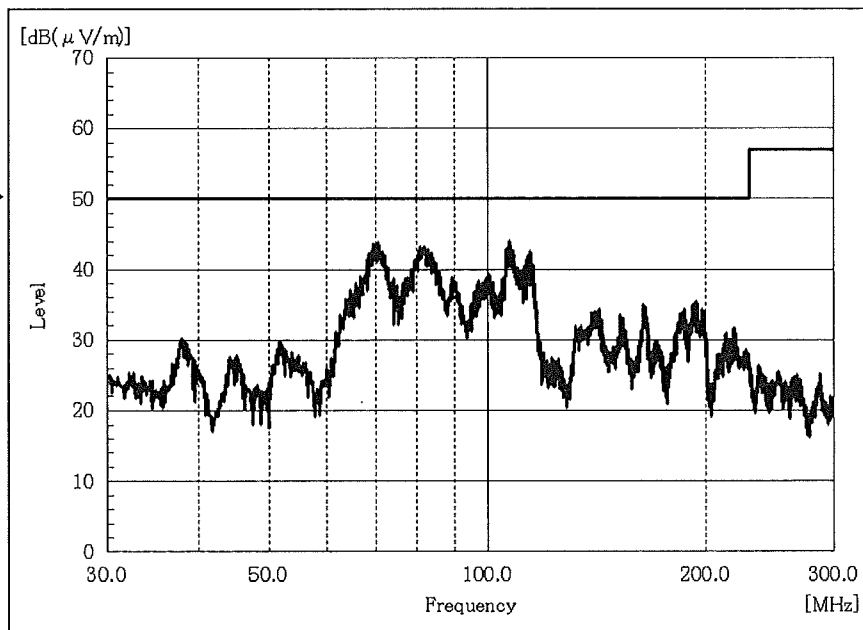

2.10 EMI特性

Electro-Magnetic Interference characteristics

(b) 雑音電界強度 (輻射ノイズ)

Radiated Emission

Conditions

Vin : 110 VDC

Io : 100 %

Tbp : 25 °C

12V

HORIZONTAL

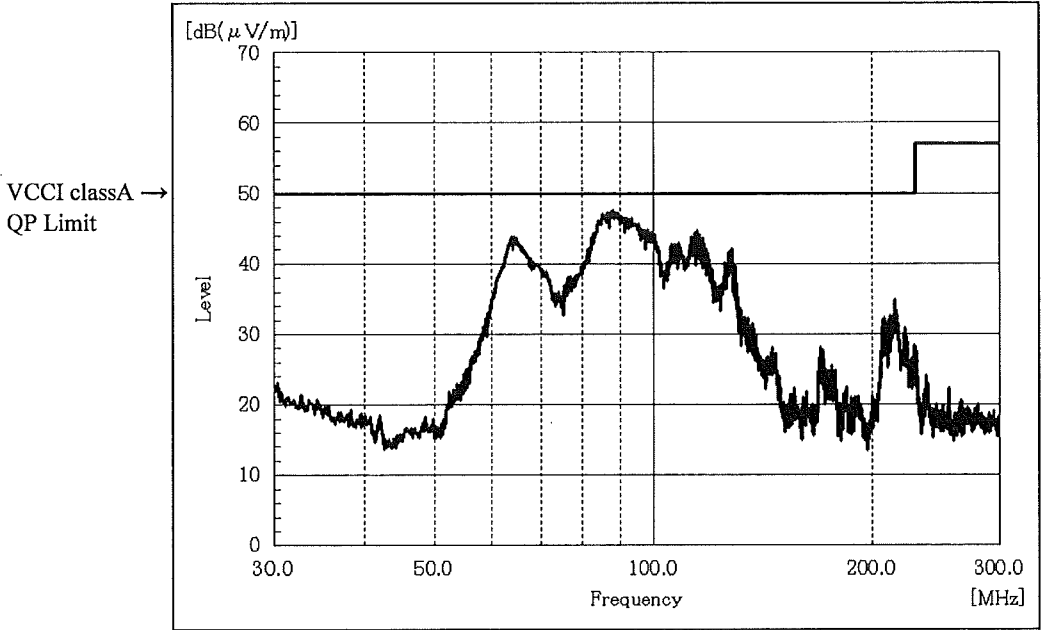

VERTICAL

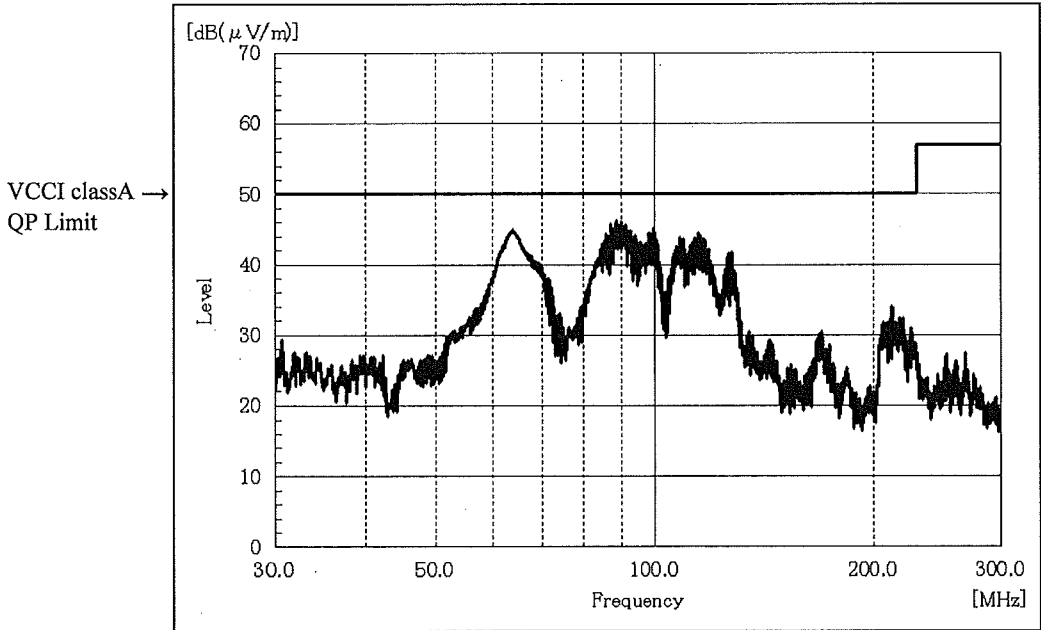

2.10 EMI特性

Electro-Magnetic Interference characteristics

(b) 雑音電界強度 (輻射ノイズ)

Radiated Emission

Conditions

Vin : 110 VDC

Io : 100 %

Tbp : 25 °C

15V

HORIZONTAL

VCCI classA →
QP Limit

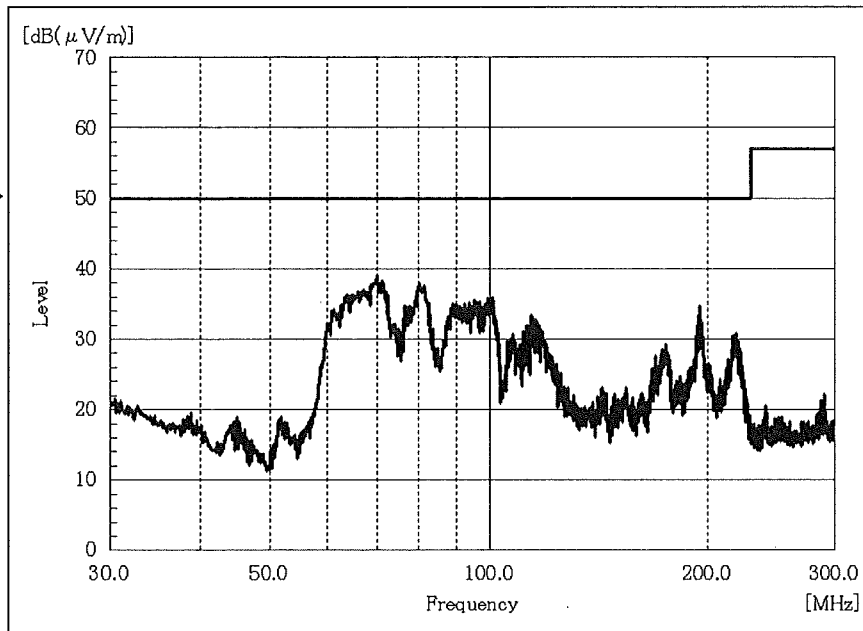

VERTICAL

VCCI classA →
QP Limit

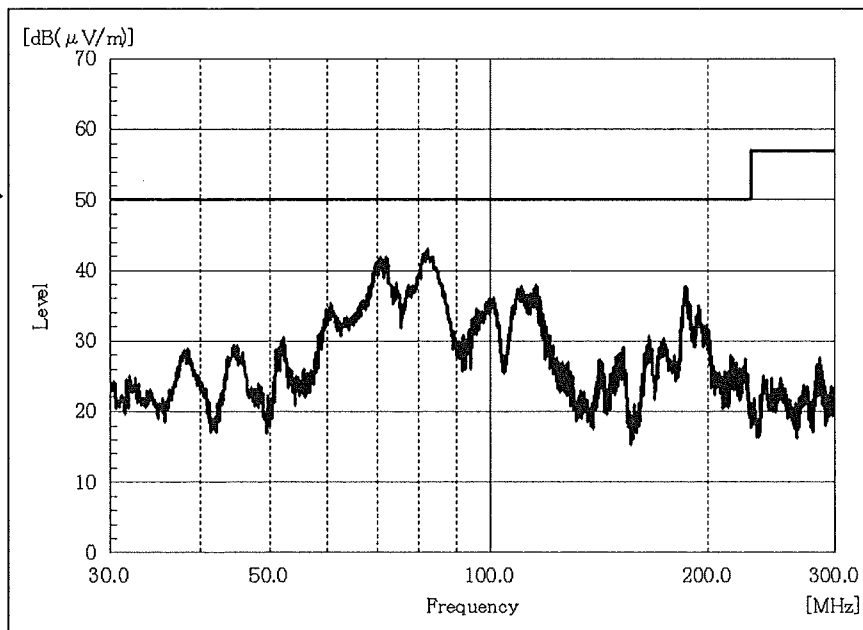

2.10 EMI特性

Electro-Magnetic Interference characteristics

(b) 雑音電界強度 (輻射ノイズ)

Radiated Emission

Conditions

Vin : 110 VDC

Io : 100 %

Tbp : 25 °C

24V

HORIZONTAL

VCCI classA →
QP Limit

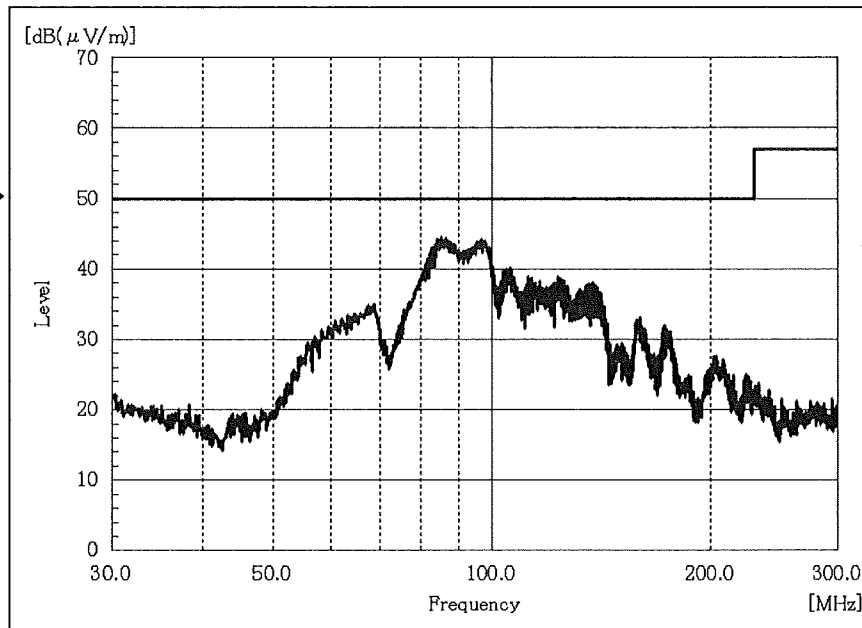

VERTICAL

VCCI classA →
QP Limit

