



# CN50A110-\*

## EVALUATION DATA

### 型式データ

DWG.NO. C256-53-01/50-B		
承認	査閲	担当
 1. Oct '10	 29. Sep '10	 29. Sep '10

## INDEX

1. 測定方法	Evaluation Method	PAGE
1.1	測定回路 Measurement Circuits .....	T-1
	(1) 静特性、過電流保護特性、出力リップル、ノイズ波形 Steady state characteristics, Over current protection (OCP) characteristics and Output ripple and noise waveform	
	(2) 過渡応答、過電圧保護特性、その他 Dynamic response, Over voltage protection (OVP) characteristics and Other characteristics	
	(3) 入力サージ電流 (突入電流) 特性 Inrush current characteristics	
	(4) EMI 特性 Electro-Magnetic Interference characteristics	
1.2	使用測定機器 List of equipments used .....	T-3
2.	特性データ Characteristics	
2.1	静特性 Steady state data	
	(1) 入力・負荷・温度変動 Regulation - line and load, temperature drift .....	T-4
	(2) 出力電圧・リップル、ノイズ電圧 対 入力電圧 Output voltage and ripple and noise voltage vs. Input voltage .....	T-6
	(3) 入力電流・効率 対 出力電流 Input current and Efficiency vs. Output current .....	T-8
	(4) 効率 対 入力電圧 Efficiency vs. Input voltage .....	T-10
	(5) 効率 対 ベースプレート温度 Efficiency vs. Baseplate temperature .....	T-12
	(6) 起動・停止電圧特性 Start and Stop voltage characteristics .....	T-14
2.2	待機電力特性 Standby power characteristics .....	T-16
2.3	通電ドリフト特性 Warm up voltage drift characteristics .....	T-18
2.4	過電流保護特性 Over current protection (OCP) characteristics .....	T-20
2.5	過電圧保護特性 Over voltage protection (OVP) characteristics .....	T-22
2.6	出力立ち上がり、立ち下がり特性 Output rise and fall characteristics .....	T-24
2.7	過渡応答(負荷急変)特性 Dynamic load response characteristics .....	T-32
2.8	入力サージ電流(突入電流)特性 Inrush current characteristics .....	T-34
2.9	出力リップル、ノイズ波形 Output ripple and noise waveform .....	T-35
2.10	EMI特性 Electro-Magnetic Interference characteristics .....	T-37

## 使用記号 Terminology used

Definition		
Vin .....	入力電圧	Input voltage
Vo .....	出力電圧	Output voltage
Vcnt .....	CNT電圧	CNT voltage
Iin .....	入力電流	Input current
Io .....	出力電流	Output current
Tbp .....	ベースプレート温度	Baseplate temperature
Ta .....	周囲温度	Ambient temperature
f .....	周波数	Frequency

1. 測定方法 Evaluation Method

1.1 測定回路 Measurement Circuits

- (1) 静特性、過電流保護特性、出力リップル、ノイズ波形  
Steady state characteristics, Over current protection (OCP) characteristics and Output ripple and noise waveform

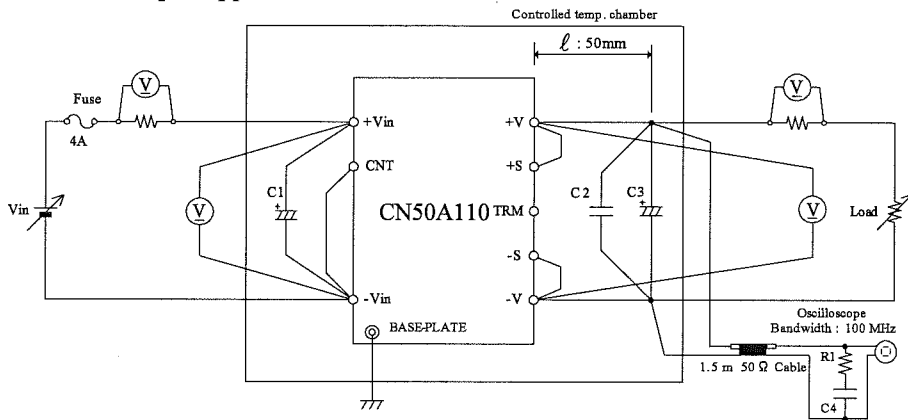

- (2) 待機電力、通電ドリフト、過電圧保護、出力立ち上がり、立ち下り、過渡応答特性  
Standby power, Warm up voltage drift, Over voltage protection (OVP), Output rise and fall and Dynamic response characteristics

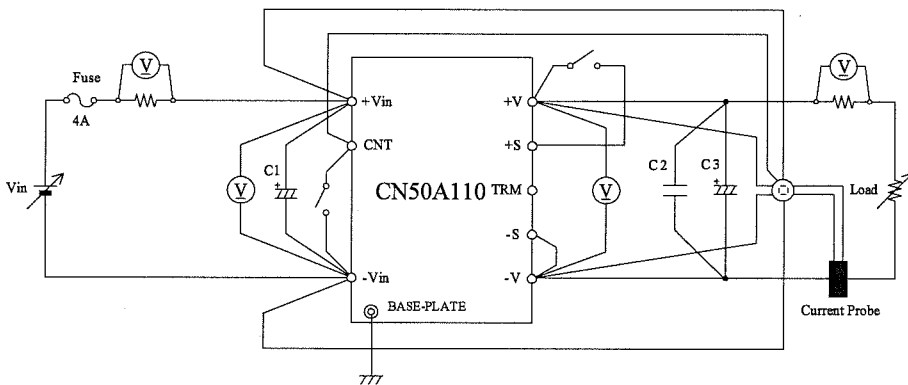

- (3) 入力サージ電流 (突入電流) 特性  
Inrush current characteristics

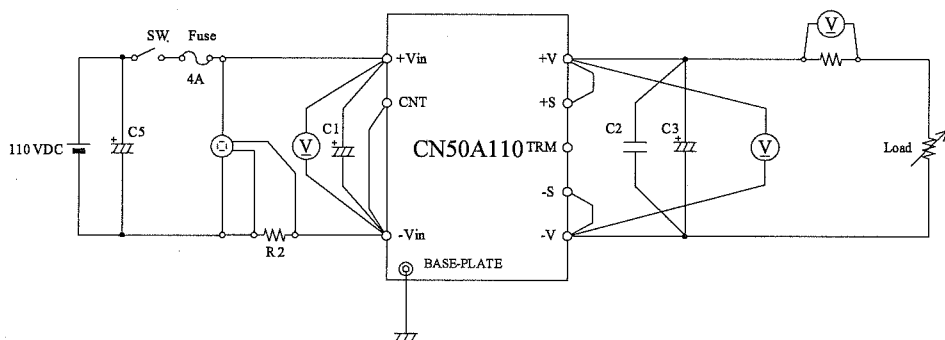

C1 : 47 $\mu$ F Electrolytic Capacitor

C2 : 2.2 $\mu$ F Ceramic Capacitor

C3 : 5V-1000 $\mu$ F Electrolytic Capacitor  
: 12V-470 $\mu$ F Electrolytic Capacitor  
: 15V-470 $\mu$ F Electrolytic Capacitor  
: 24V-220 $\mu$ F Electrolytic Capacitor

C4 : 4700pF Ceramic Capacitor

C5 : 8000 $\mu$ F Electrolytic Capacitor

R1 : 50  $\Omega$

R2 : 0.01  $\Omega$

(4) EMI特性 Electro-Magnetic Interference characteristics

(a) 雑音端子電圧 (帰還ノイズ) Conducted Emission Noise

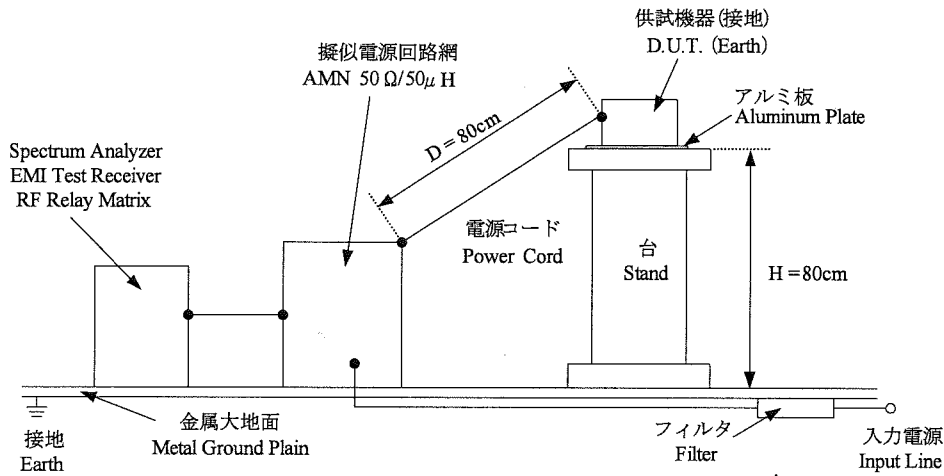

(b) 雑音電界強度(輻射ノイズ) Radiated Emission Noise

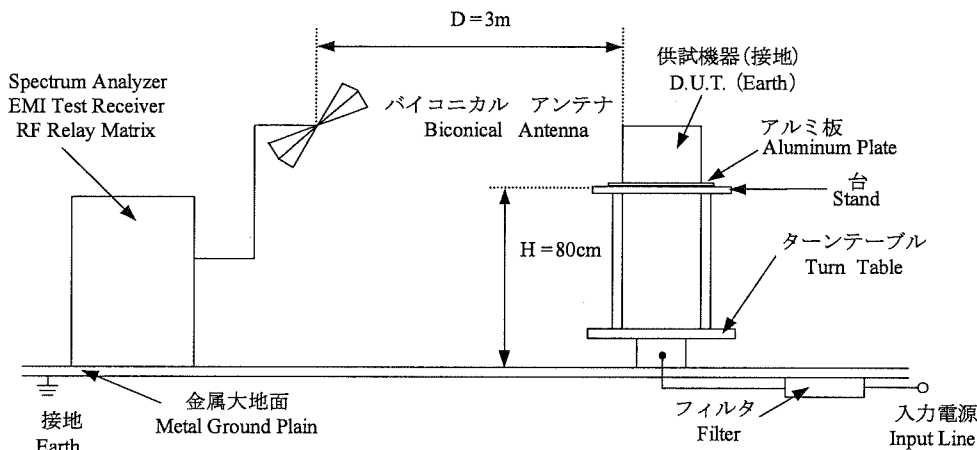

\*入出力ケーブルとしてシールドケーブルを使用  
Shielded cable used to input and output cable.

VCCI class A対応アプリケーションシステム  
VCCI class A application system

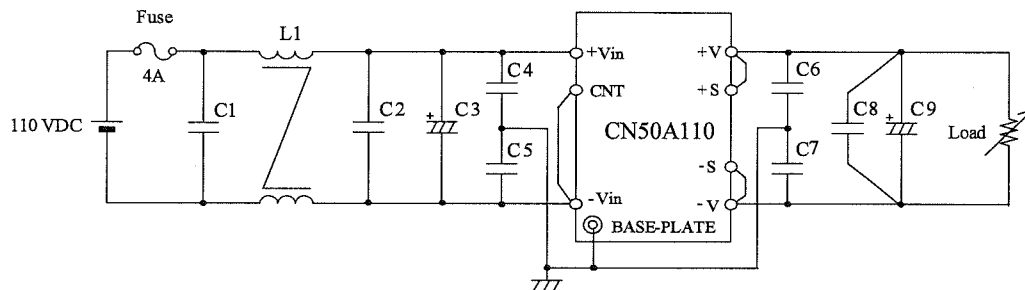

- C1,C2 : 1.5μF Film Capacitor
- C3 : 47μF Electrolytic Capacitor
- C4,C5 : 3300pF Ceramic Capacitor
- C6,C7 : 4700pF Ceramic Capacitor
- C8 : 2.2μF Ceramic Capacitor

- C9 : 5V-1000μF Electrolytic Capacitor
- : 12V-470μF Electrolytic Capacitor
- : 15V-470μF Electrolytic Capacitor
- : 24V-220μF Electrolytic Capacitor
- L1 : 1.4mH

## 1.2 使用測定機器 List of equipments used

	EQUIPMENT USED	MANUFACTURER	MODEL NO.
1	OSCILLOSCOPE	TEKTRONIX	TDS3012
2	DIGITAL STORAGE OSCILLOSCOPE	LECROY	WR6050A
3	DATA ACQUISITION / SWITCH UNIT	AGILENT	34970A
4	CURRENT PROBE	LECROY	AP015
5	SHUNT RESISTER	YOKOGAWA ELECT.	2215
6	CONTROLLED TEMP. CHAMBER	ESPEC CORP.	SU-261
7	SPECTRUM ANALYZER EMI TEST RECEIVER	ROHDE & SCHWARZ	ESCI
8	RF SELECTOR	TOYO, CORP	NS4900
9	AMN	SCHWARZBECK	NNLK8121
10	ANTENNA(BICONICAL ANTENNA)	TESEQ	CBL6111D
11	DYNAMIC DUMMY LOAD	TAKASAGO	FK-400L
12	AC POWER SUPPLY	TAKASAGO	AA-2000XG

## 2. 特性データ Characteristics

## 2.1 静特性 Steady state data

(1) 入力・負荷・温度変動 Regulation - line and load, Temperature drift

5V

1. Regulation - line and load				Condition Tbp : 25°C	
Io \ Vin	60VDC	110VDC	160VDC	Line regulation	
0%	5.015V	5.016V	5.015V	1mV	0.020%
50%	5.016V	5.015V	5.014V	2mV	0.040%
100%	5.015V	5.014V	5.013V	2mV	0.040%
Load regulation	1mV	2mV	2mV		
	0.020%	0.040%	0.040%		

2. Temperature drift Conditions Vin : 110VDC  
Io : 100%

Tbp	-40°C	+25°C	+100°C	Temperature stability	
Vo	5.027V	5.014V	5.002V	25mV	0.500%

12V

1. Regulation - line and load				Condition Tbp : 25°C	
Io \ Vin	60VDC	110VDC	160VDC	Line regulation	
0%	11.977V	11.977V	11.977V	0mV	0.000%
50%	11.977V	11.977V	11.976V	1mV	0.009%
100%	11.976V	11.976V	11.975V	1mV	0.009%
Load regulation	1mV	1mV	2mV		
	0.009%	0.009%	0.017%		

2. Temperature drift Conditions Vin : 110VDC  
Io : 100%

Tbp	-40°C	+25°C	+100°C	Temperature stability	
Vo	11.981V	11.976V	11.987V	11mV	0.092%

(1) 入力・負荷・温度変動 Regulation - line and load, Temperature drift

15V

1. Regulation - line and load				Condition Tbp : 25°C	
Io \ Vin	60VDC	110VDC	160VDC	Line regulation	
0%	14.996V	14.996V	14.996V	0mV	0.000%
50%	14.996V	14.996V	14.996V	0mV	0.000%
100%	14.996V	14.996V	14.995V	1mV	0.007%
Load regulation	0mV	0mV	1mV		
	0.000%	0.000%	0.007%		

2. Temperature drift				Conditions Vin : 110VDC Io : 100%	
Tbp	-40°C	+25°C	+100°C	Temperature stability	
Vo	15.008V	14.996V	14.993V	15mV	0.100%

24V

1. Regulation - line and load				Condition Tbp : 25°C	
Io \ Vin	60VDC	110VDC	160VDC	Line regulation	
0%	23.966V	23.966V	23.966V	0mV	0.000%
50%	23.966V	23.966V	23.965V	1mV	0.005%
100%	23.966V	23.965V	23.965V	1mV	0.005%
Load regulation	0mV	1mV	1mV		
	0.000%	0.005%	0.005%		

2. Temperature drift				Conditions Vin : 110VDC Io : 100%	
Tbp	-40°C	+25°C	+100°C	Temperature stability	
Vo	23.993V	23.965V	23.975V	28mV	0.117%

(2) 出力電圧・出力リップル、ノイズ電圧 対 入力電圧

Output voltage and ripple and noise voltage vs. Input voltage

Conditions  $I_o$  : 100 %

$T_{bp}$  : -40 °C

: 25 °C

: 100 °C



5V

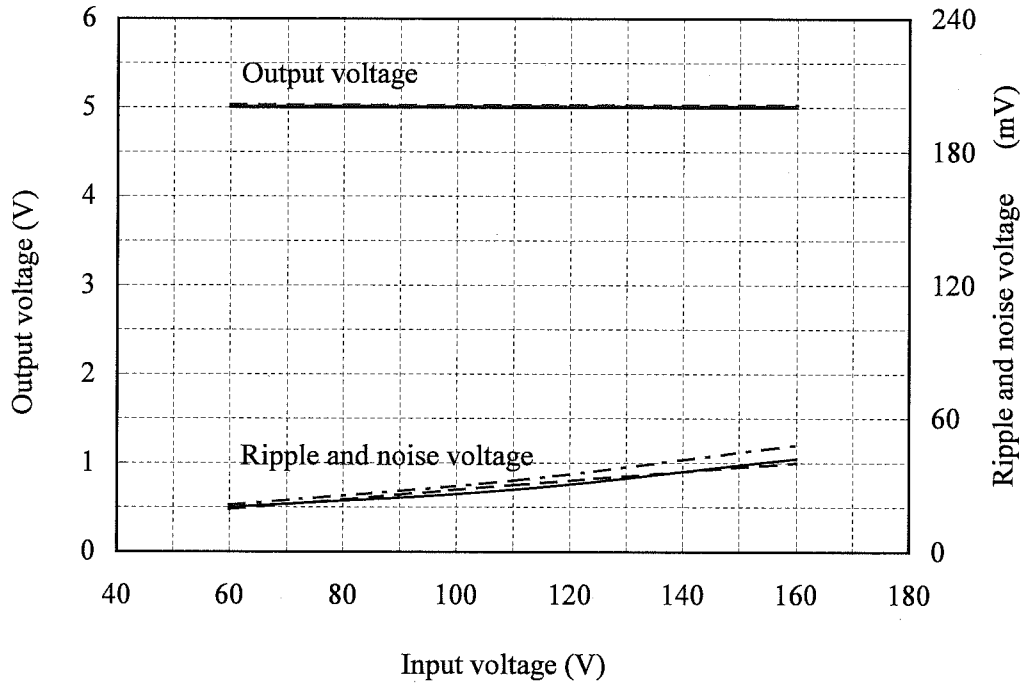

12V

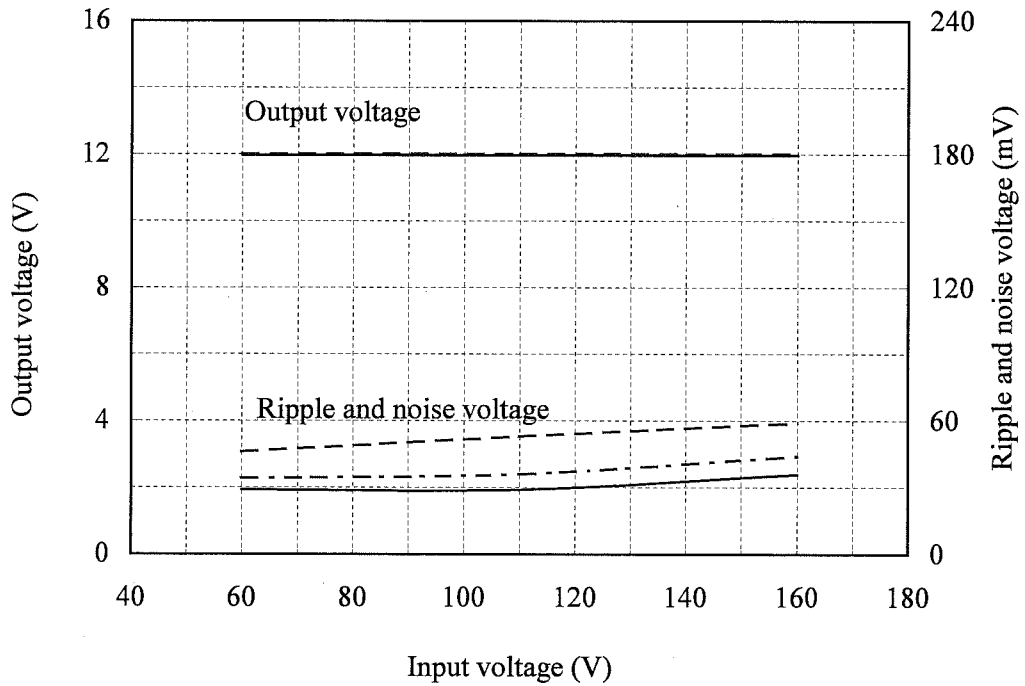



(2) 出力電圧・出力リップル、ノイズ電圧 対 入力電圧

Output voltage and ripple and noise voltage vs. Input voltage

Conditions  $I_o$  : 100 %

$T_{bp}$  : -40 °C

: 25 °C

: 100 °C



15V

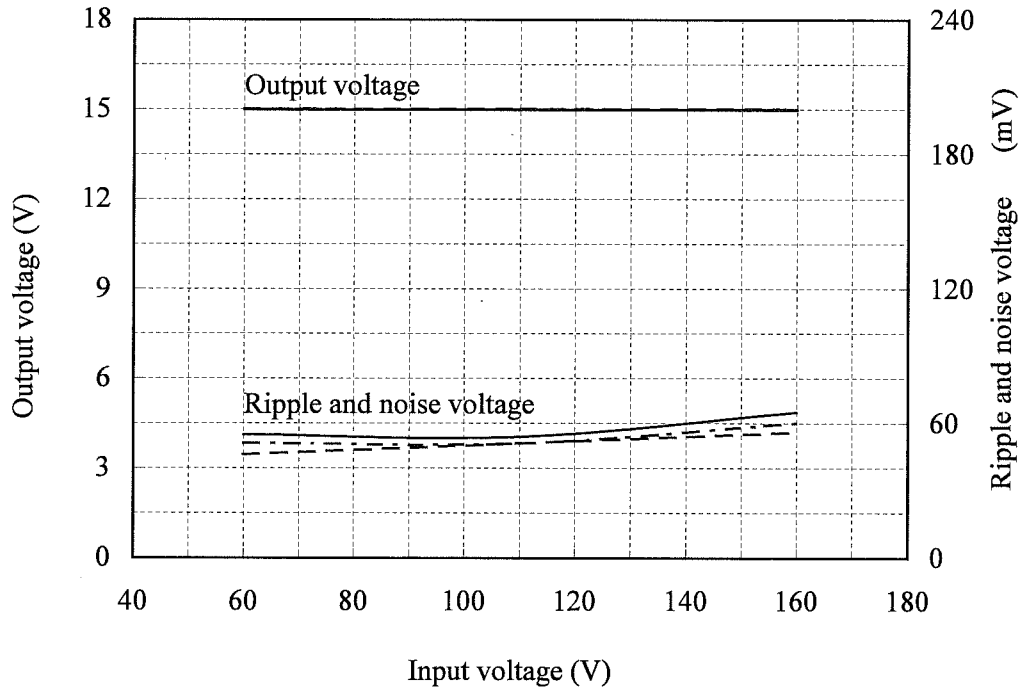

24V

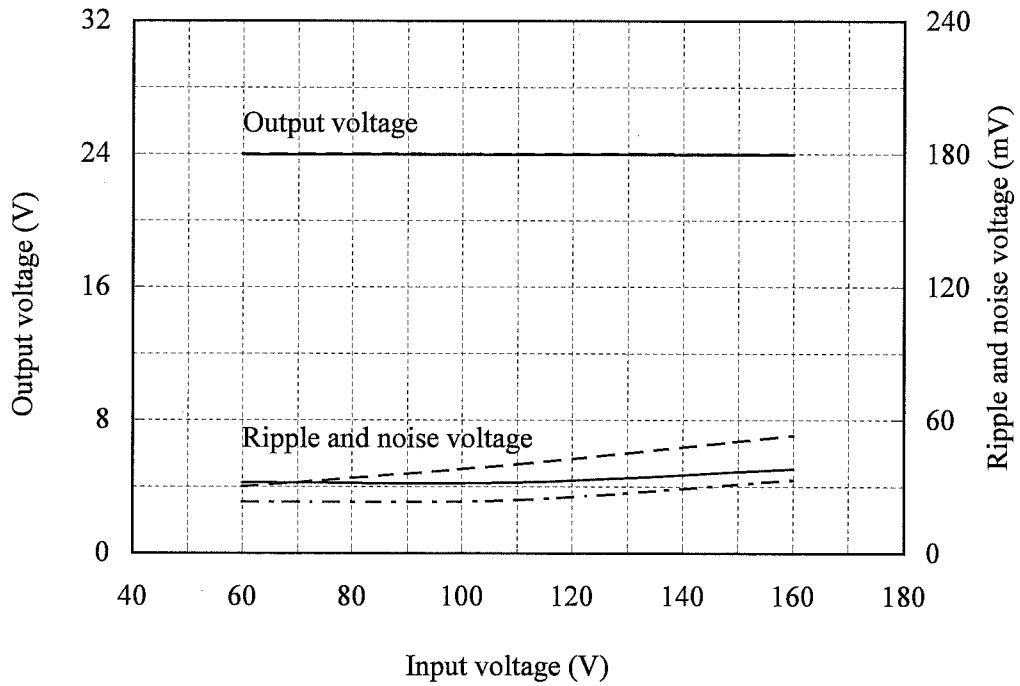

(3) 入力電流・効率対出力電流  
Input current and Efficiency vs. Output current

Conditions Vin : 60 VDC ---  
: 110 VDC - - -  
: 160 VDC ———  
Tbp : 25 °C

5V

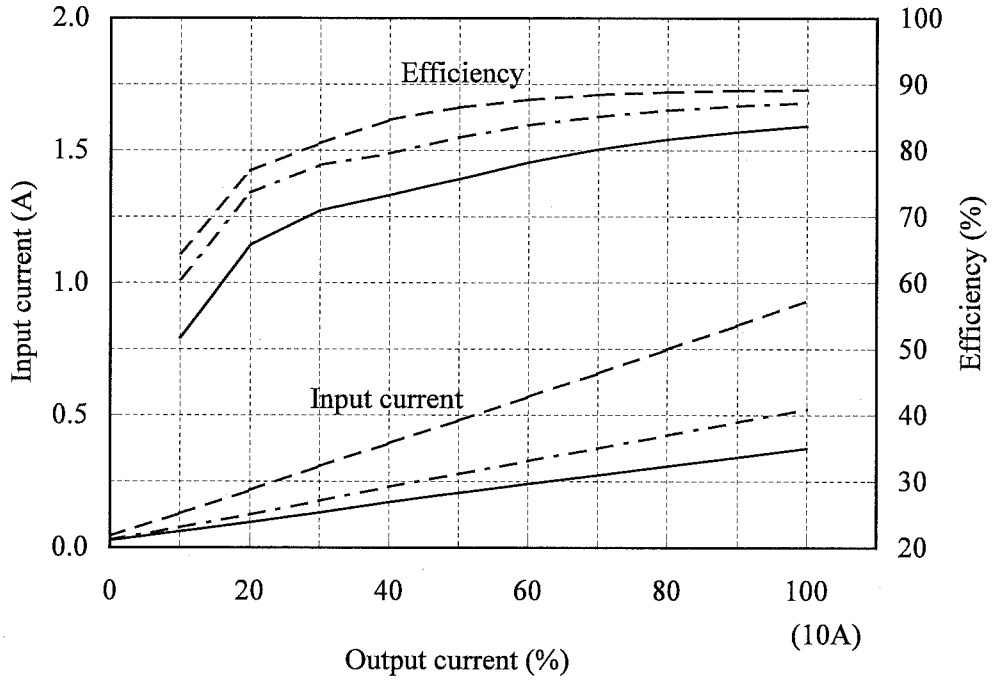

12V

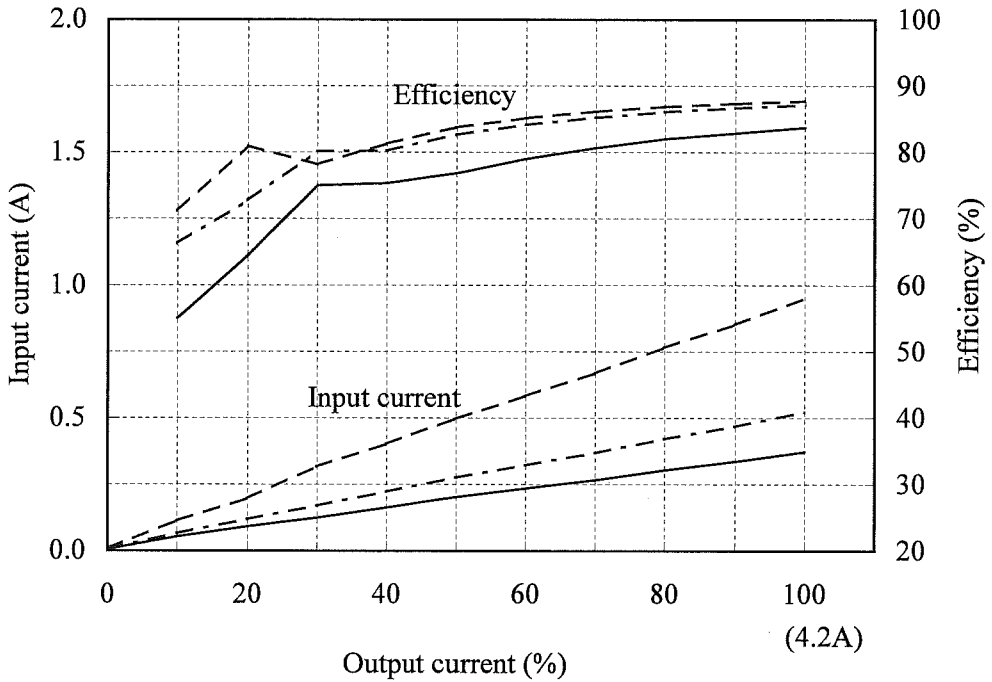

(3) 入力電流・効率対出力電流

Input current and Efficiency vs. Output current

Conditions Vin : 60 VDC ---  
 : 110 VDC - - -  
 : 160 VDC ———  
 Tbp : 25 °C

15V

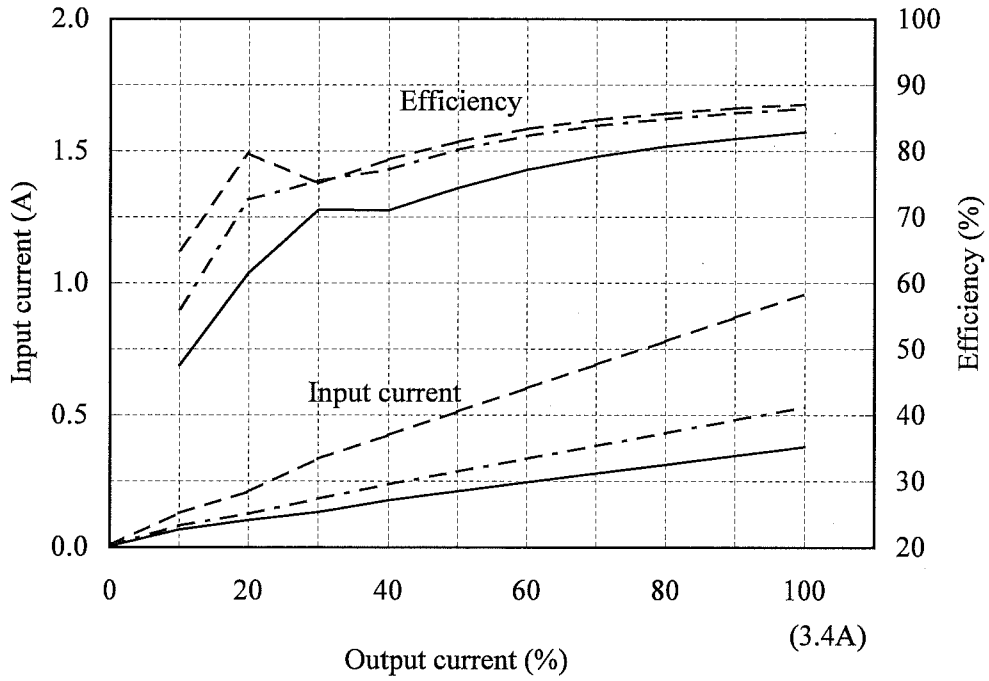

24V

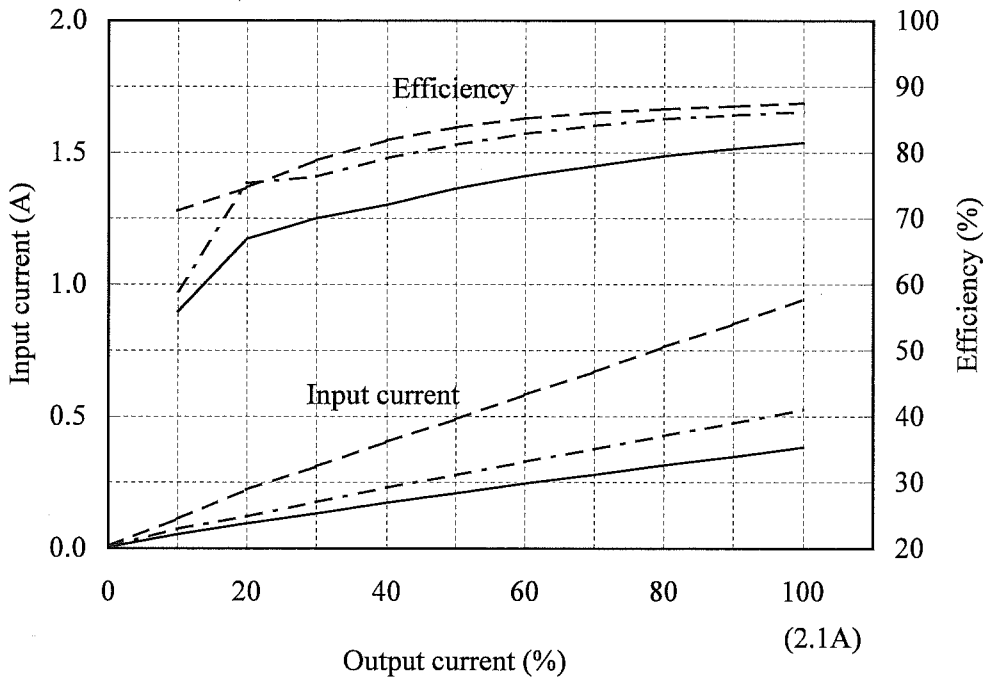

(4) 効率 対 入力電圧  
Efficiency vs. Input voltage

Conditions Io : 50 % -----  
                  : 100 %        —————  
                  Tbp : 25 °C

5V

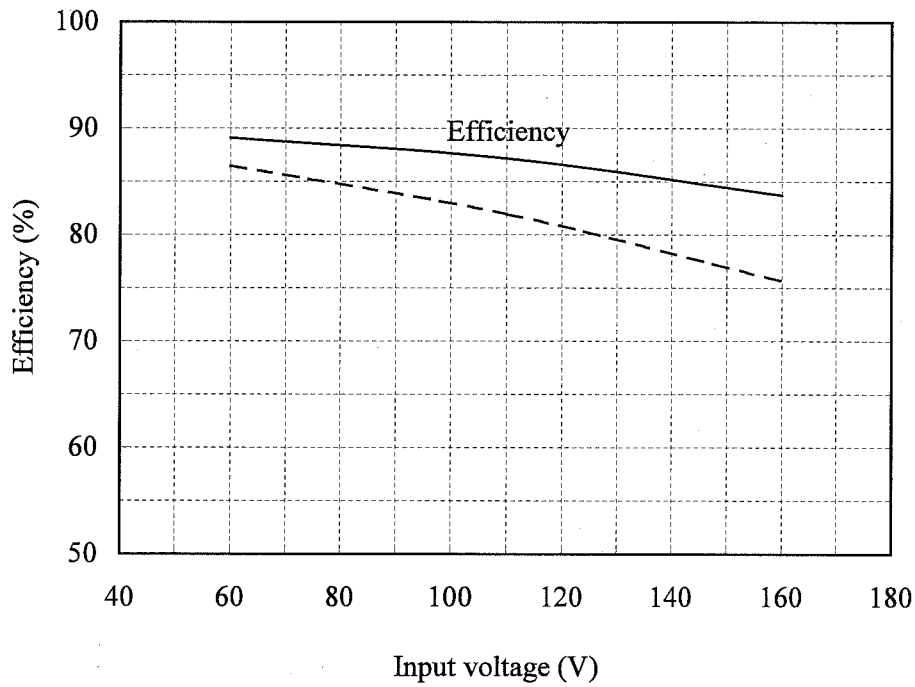

12V

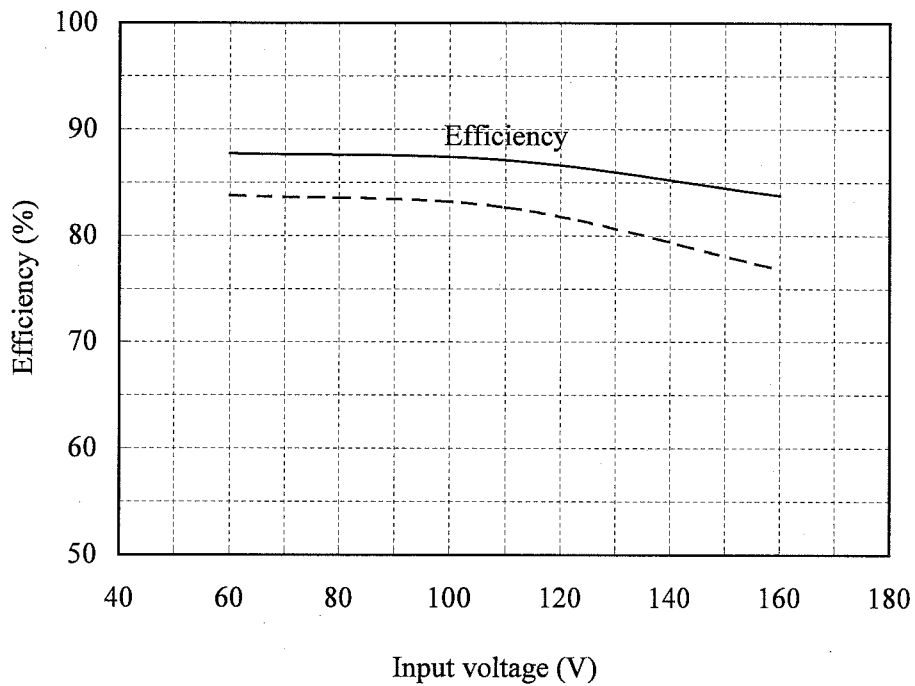

(4) 効率 対 入力電圧  
Efficiency vs. Input voltage

Conditions Io : 50 %    ----  
                  : 100 %    ——  
                  Tbp : 25 °C

15V

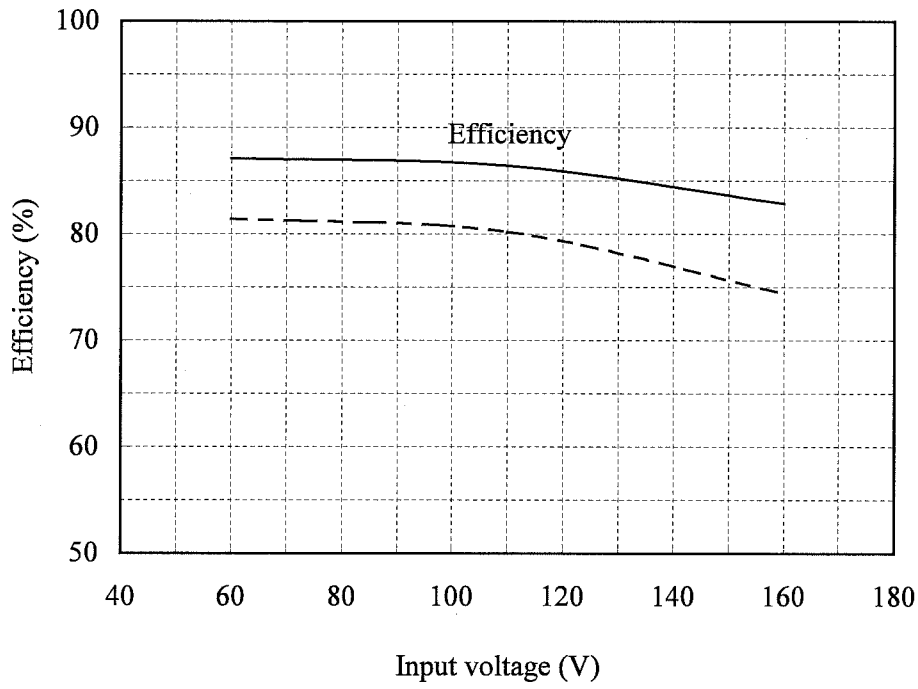

24V

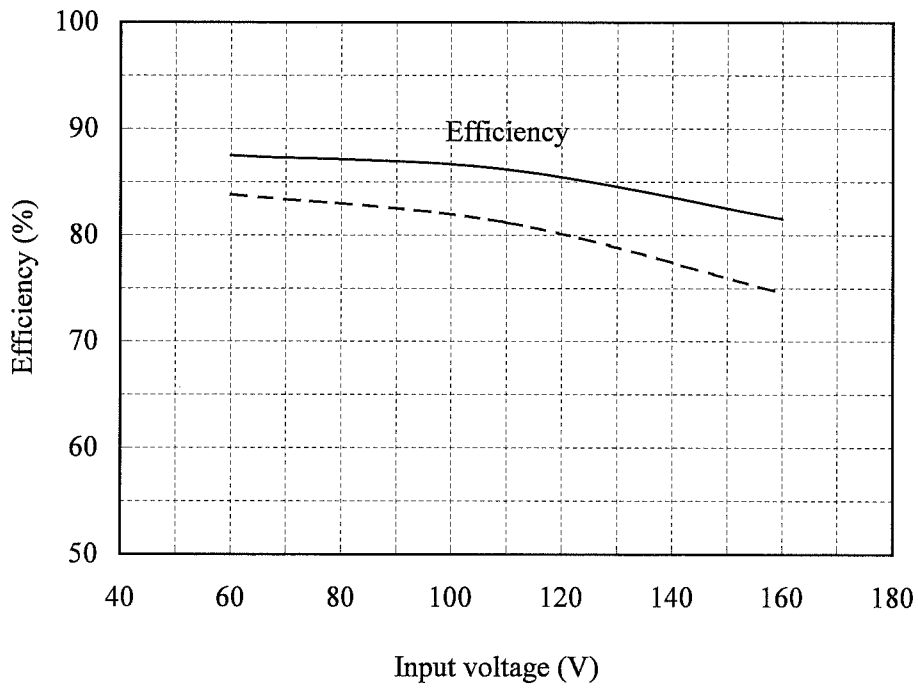

(5) 効率対ベースプレート温度  
Efficiency vs. Baseplate temperature

Conditions Vin : 110 VDC  
Io : 100 %

5V

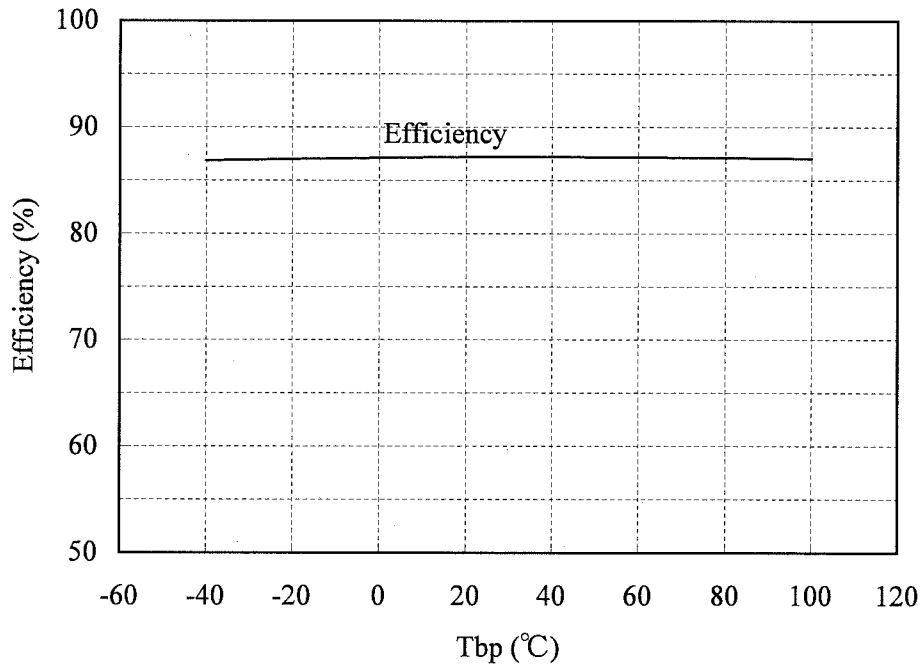

12V

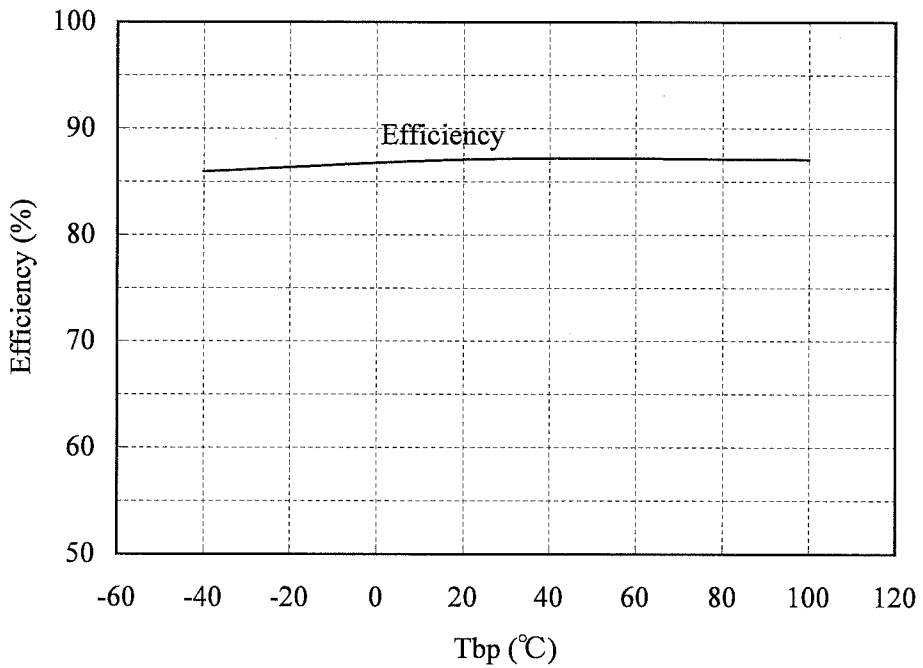

(5) 効率 対 ベースプレート温度  
Efficiency vs. Baseplate temperature

Conditions  $V_{in}$  : 110 VDC  
 $I_o$  : 100 %

15V

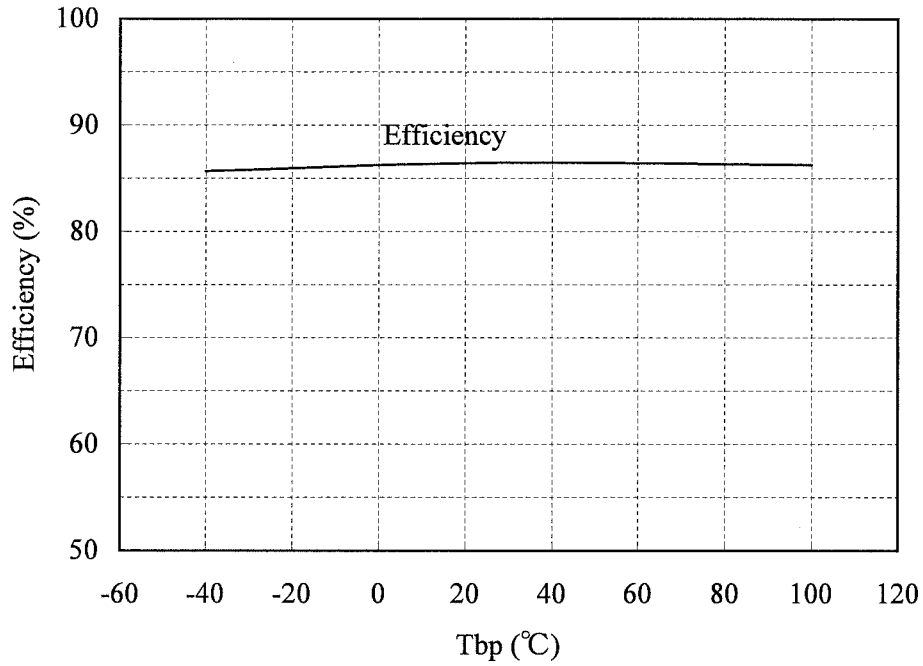

24V

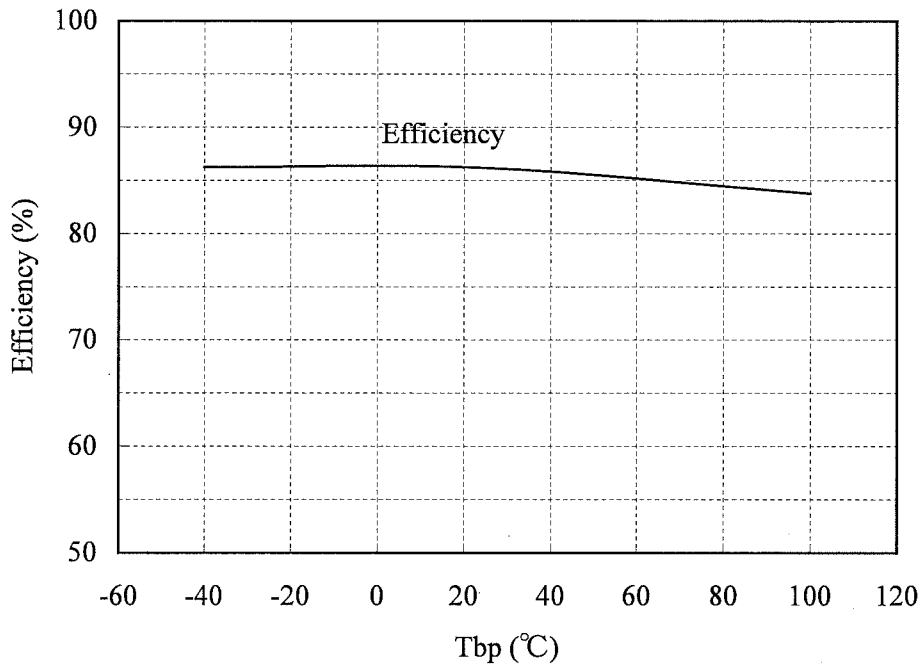

(6) 起動・停止電圧特性  
Start and Stop voltage characteristics

出力電圧 対 入力電圧  
Output voltage vs. Input voltage

Conditions  $I_o$  : 100 %  
 $T_{bp}$  : 25 °C

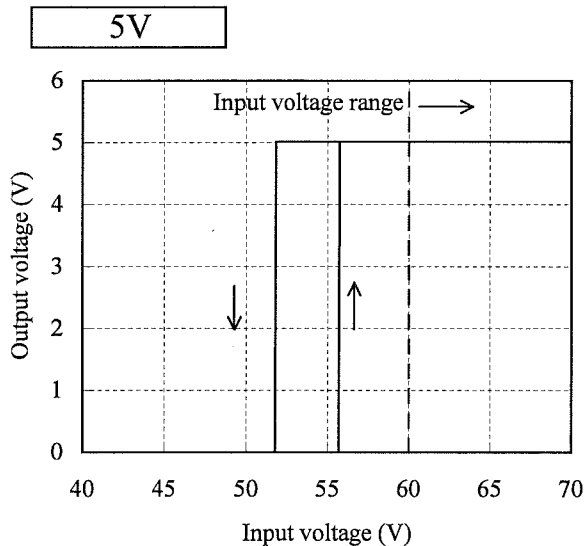

入力電流 対 入力電圧  
Input current vs. Input voltage

Conditions  $I_o$  : 100 %  
 $T_{bp}$  : 25 °C

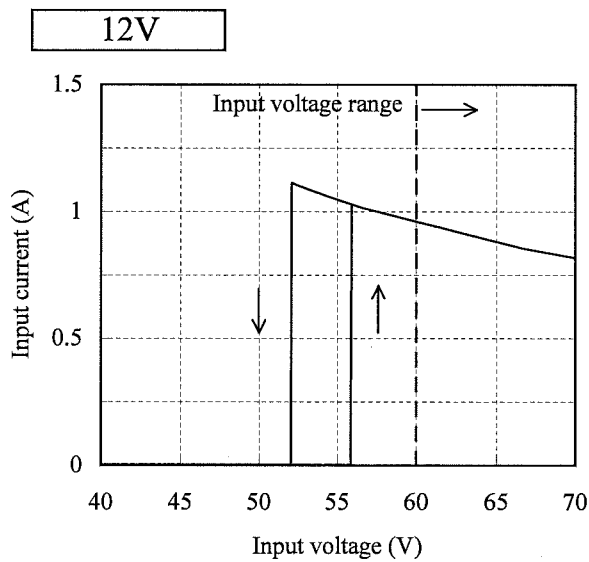
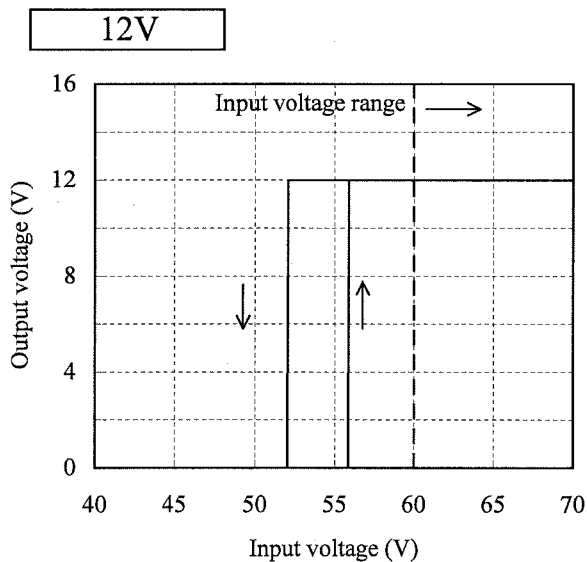
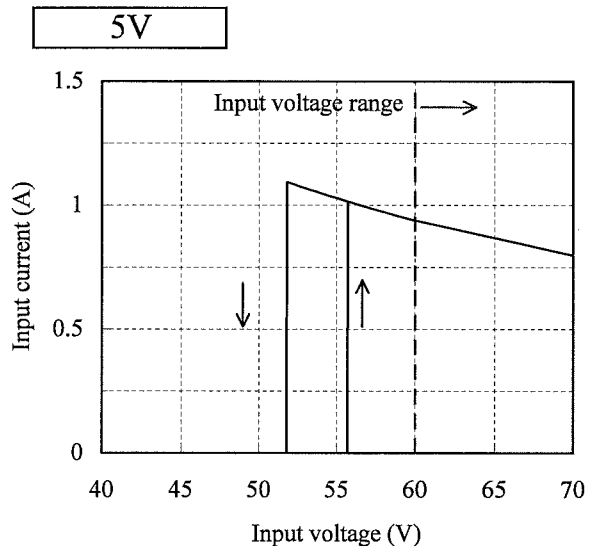



(6) 起動・停止電圧特性  
Start and Stop voltage characteristics

出力電圧 対 入力電圧  
Output voltage vs. Input voltage

Conditions  $I_o$  : 100 %  
 $T_{bp}$  : 25 °C

入力電流 対 入力電圧  
Input current vs. Input voltage

Conditions  $I_o$  : 100 %  
 $T_{bp}$  : 25 °C

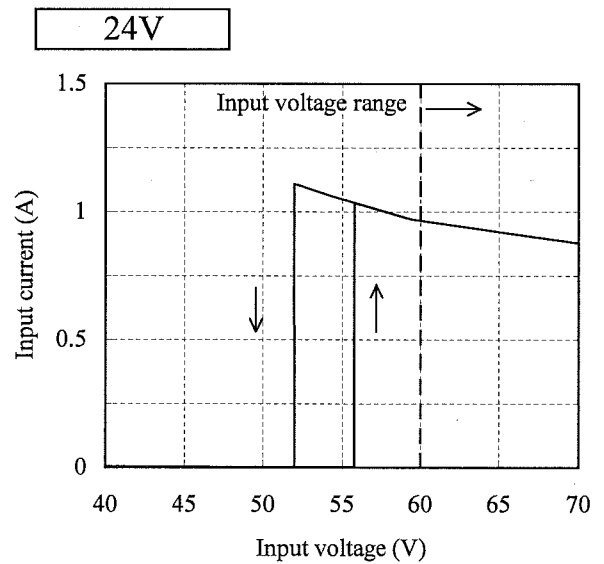
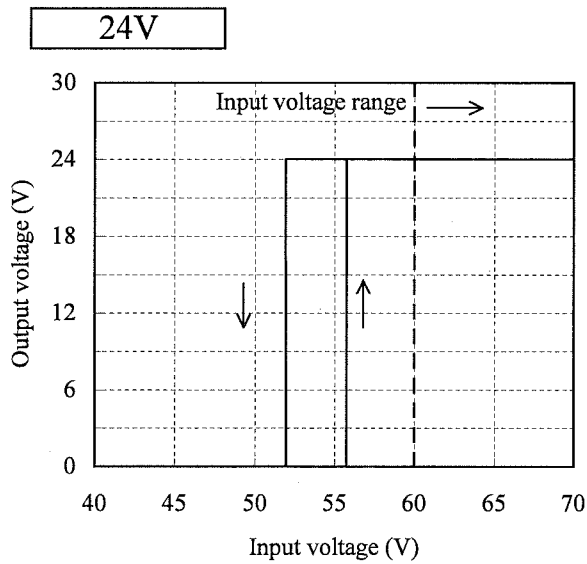
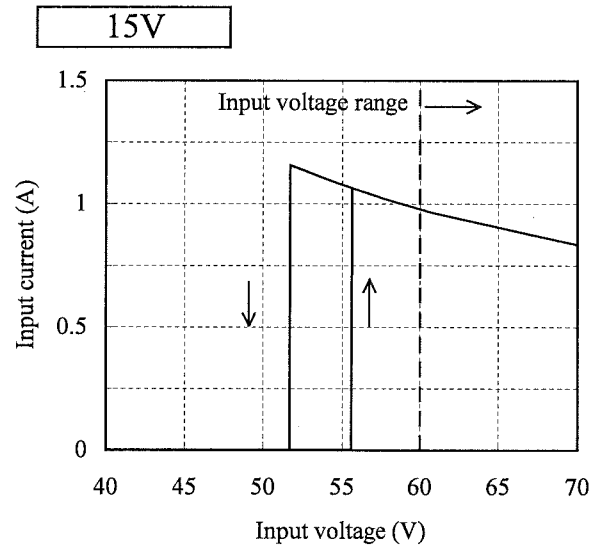
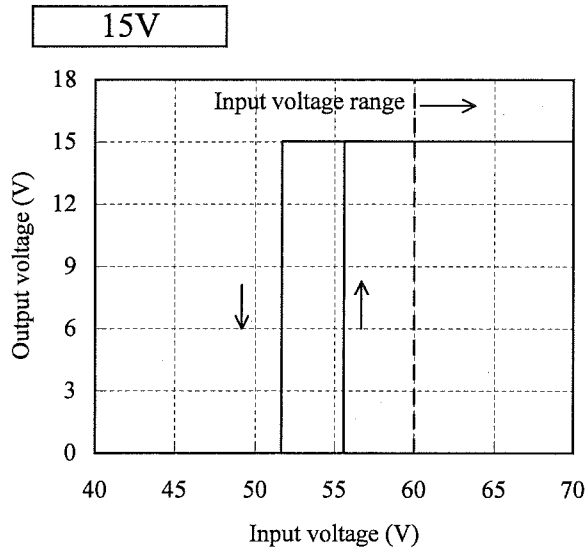

2.2 待機電力特性

Standby power characteristics

Conditions Tbp : 25 °C

5V

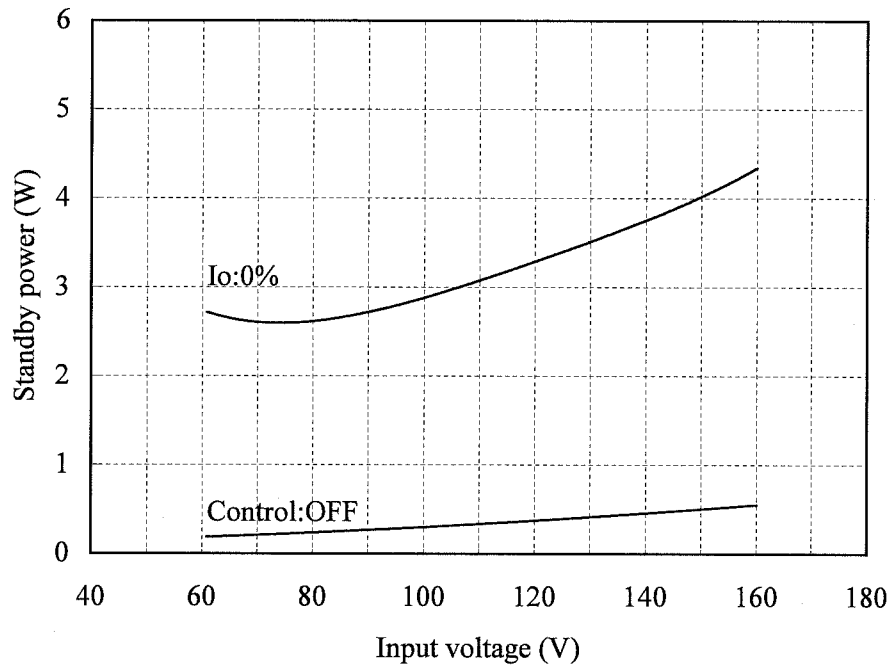

12V

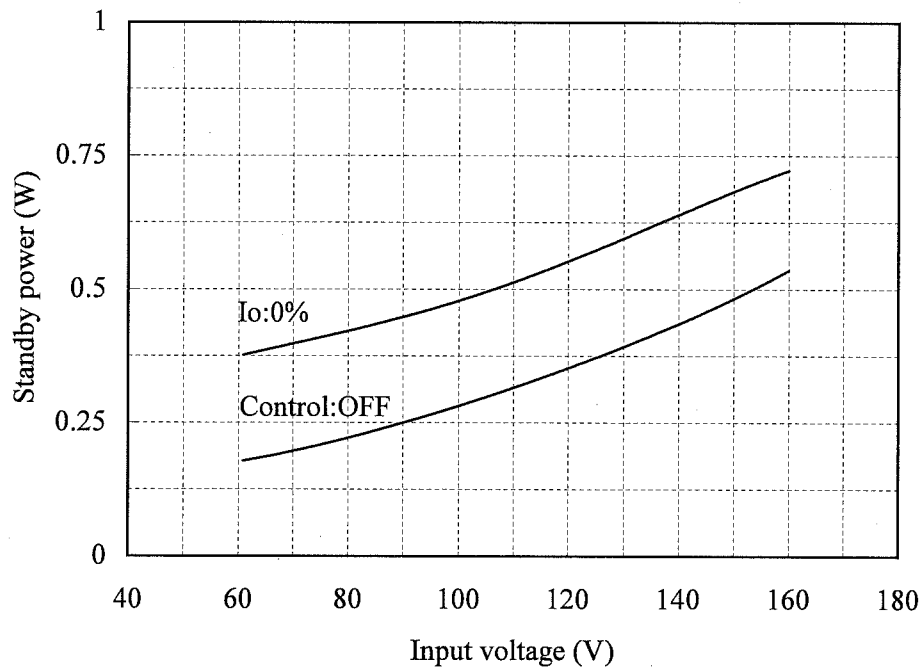

2.2 待機電力特性  
Standby power characteristics

Conditions Tbp : 25 °C

15V

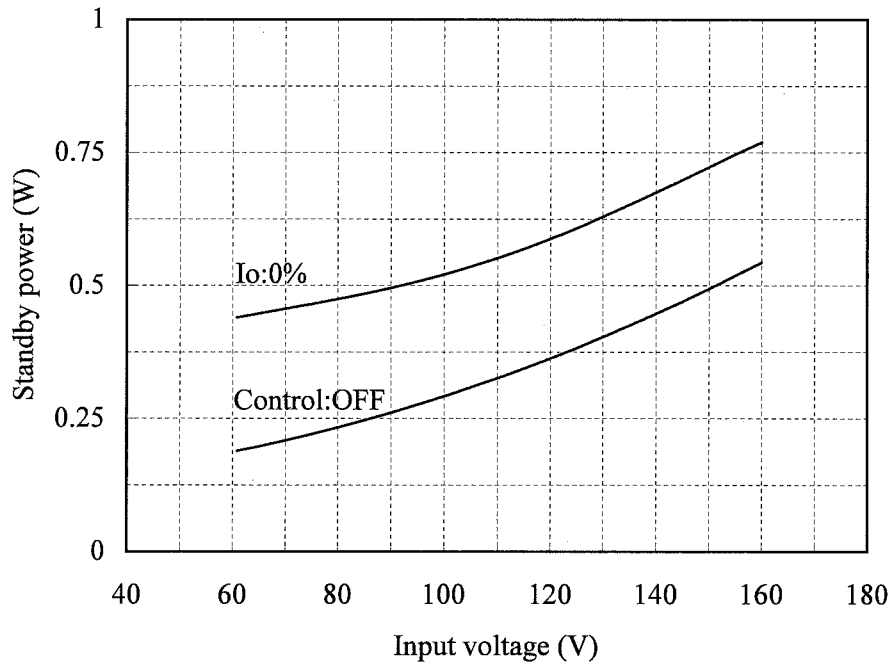

24V

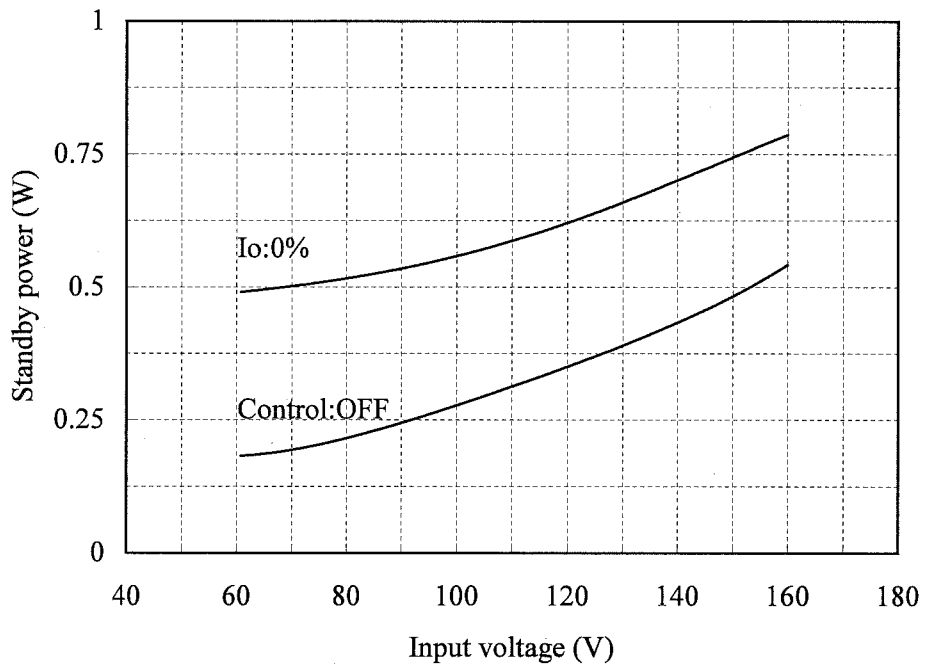

2.3 通電ドリフト特性

Warm up voltage drift characteristics

Conditions

V<sub>in</sub> : 110 VDC

I<sub>o</sub> : 100 %

T<sub>a</sub> : 25 °C

5V

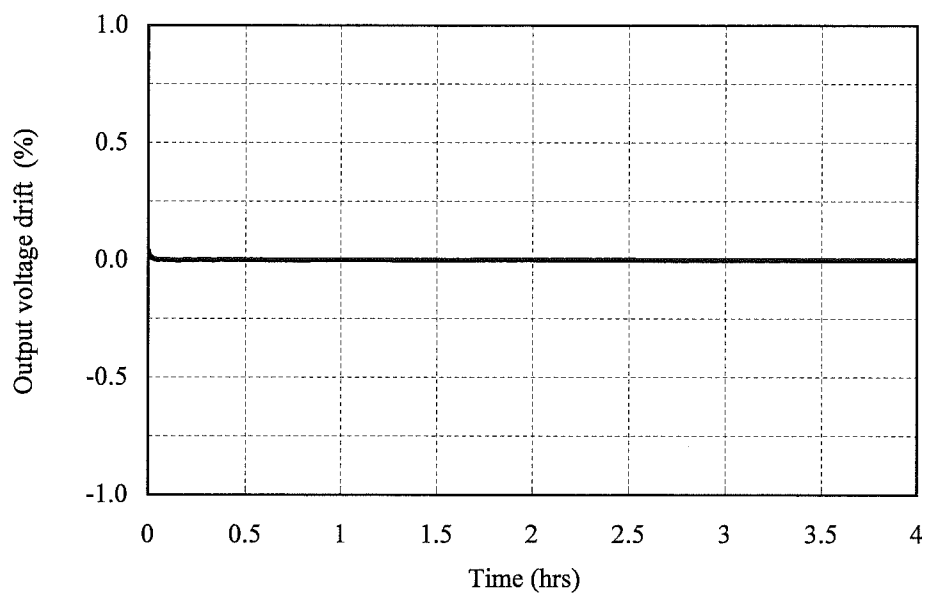

12V

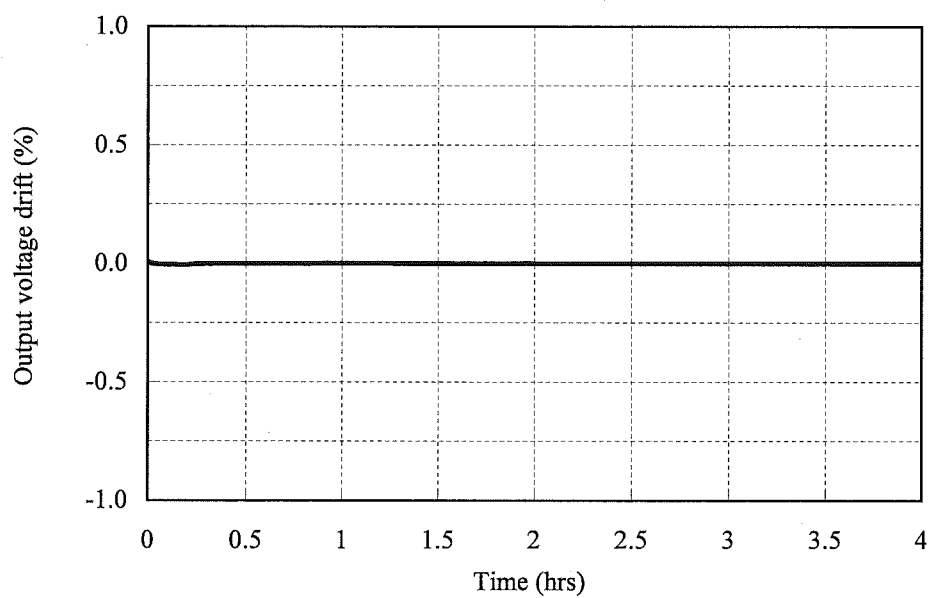

2.3 通電ドリフト特性

Warm up voltage drift characteristics

Conditions

Vin : 110 VDC

Io : 100 %

Ta : 25 °C

15V

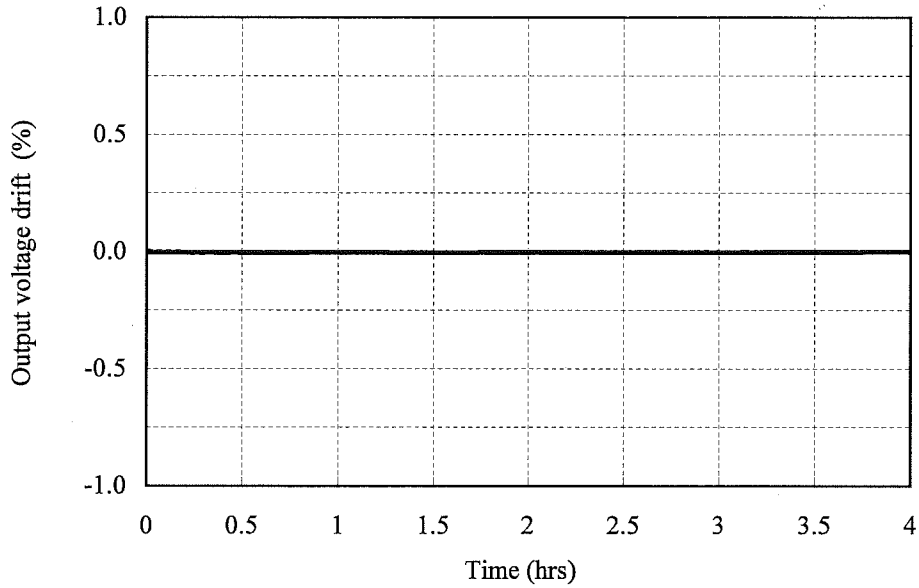

24V

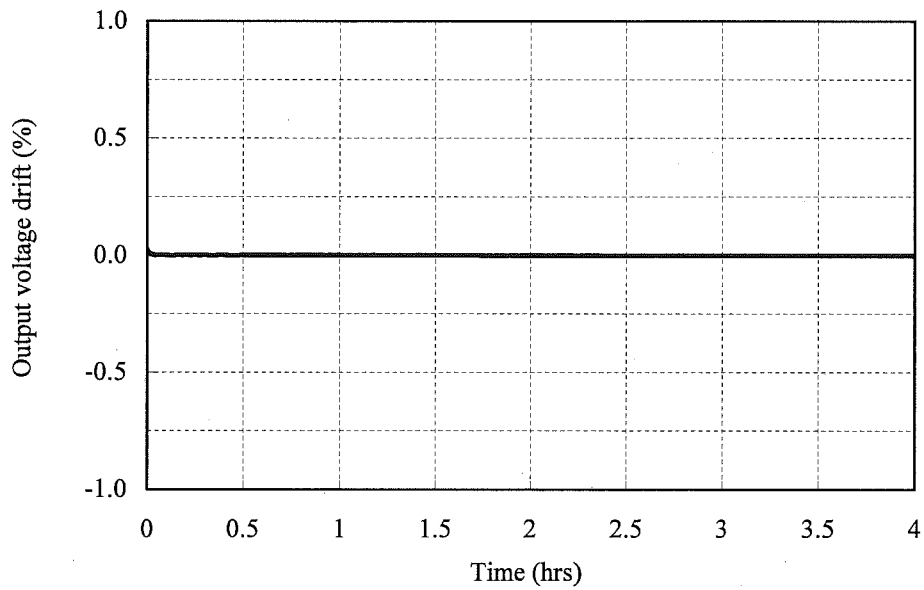

2.4 過電流保護特性

Over current protection (OCP) characteristics

入力電圧依存性

Input voltage dependence

Conditions Vin : 60 VDC -----  
 : 110 VDC - - - - -  
 : 160 VDC \_\_\_\_\_  
 Tbp : 25 °C

ベースプレート温度依存性

Baseplate temperature dependence

Conditions Vin : 110 VDC  
 Tbp : -40 °C -----  
 : 25 °C - - - - -  
 : 100 °C \_\_\_\_\_

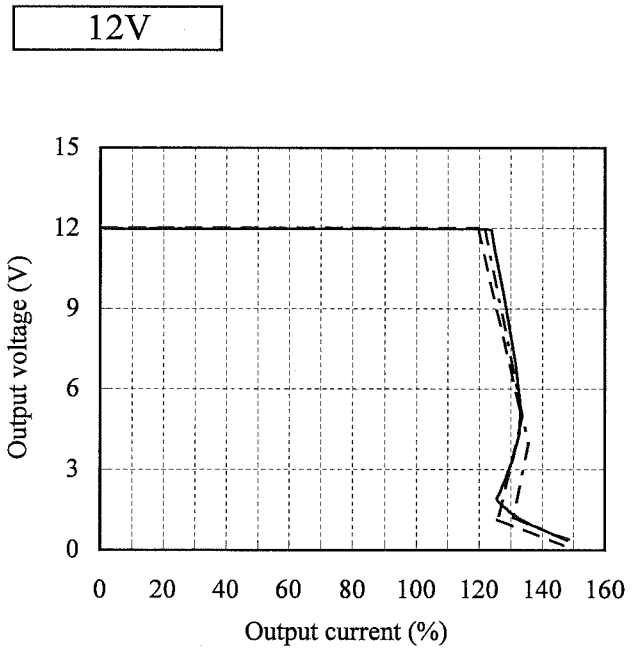
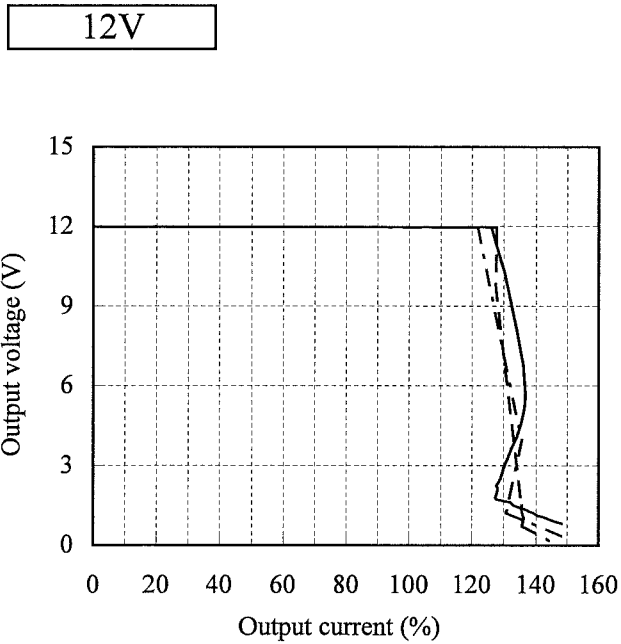
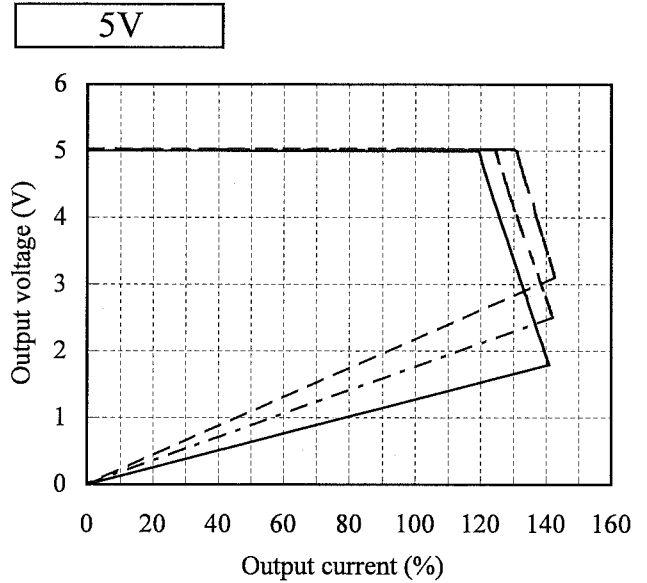
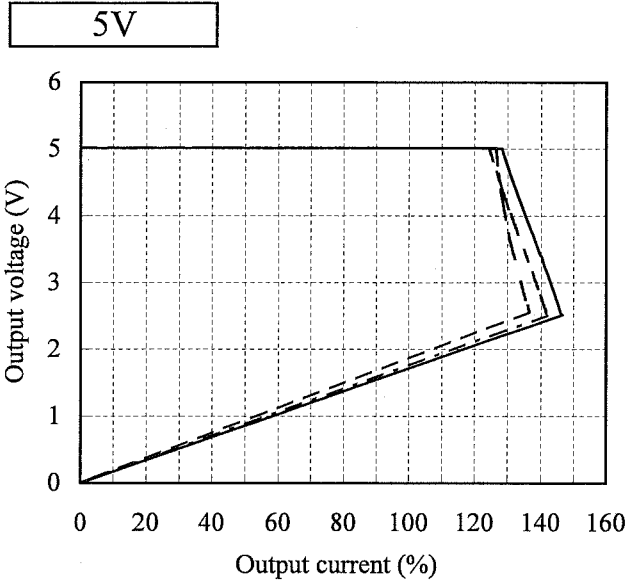

2.4 過電流保護特性

Over current protection (OCP) characteristics

入力電圧依存性

Input voltage dependence

Conditions Vin : 60 VDC -----  
 : 110 VDC - - - - -  
 : 160 VDC \_\_\_\_\_  
 Tbp : 25 °C

ベースプレート温度依存性

Baseplate temperature dependence

Conditions Vin : 110 VDC  
 Tbp : -40 °C -----  
 : 25 °C - - - - -  
 : 100 °C \_\_\_\_\_

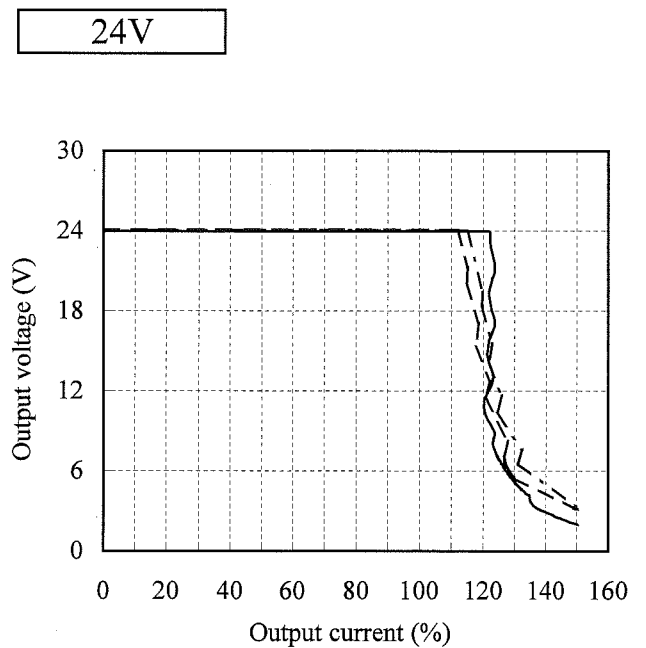
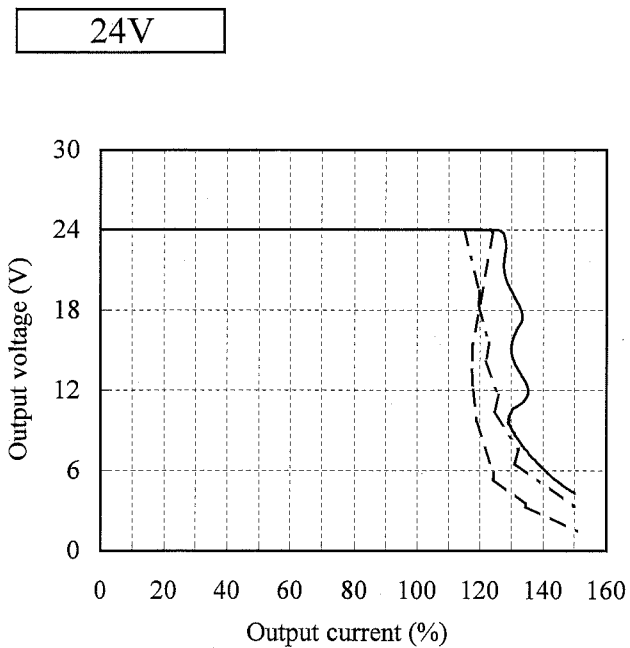
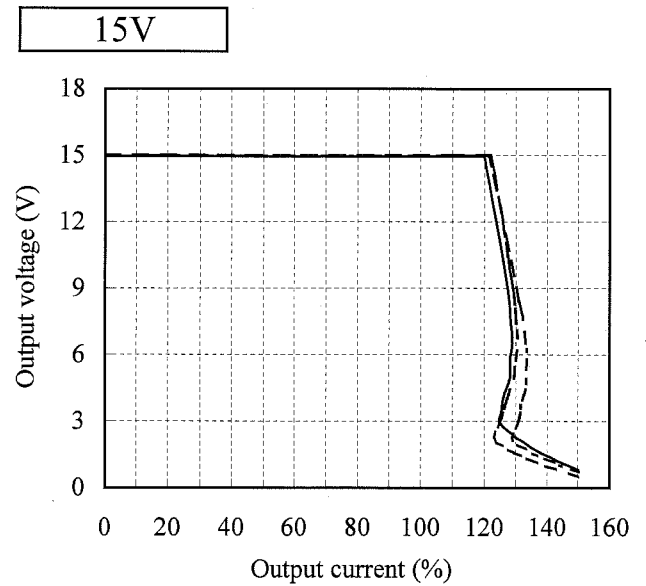
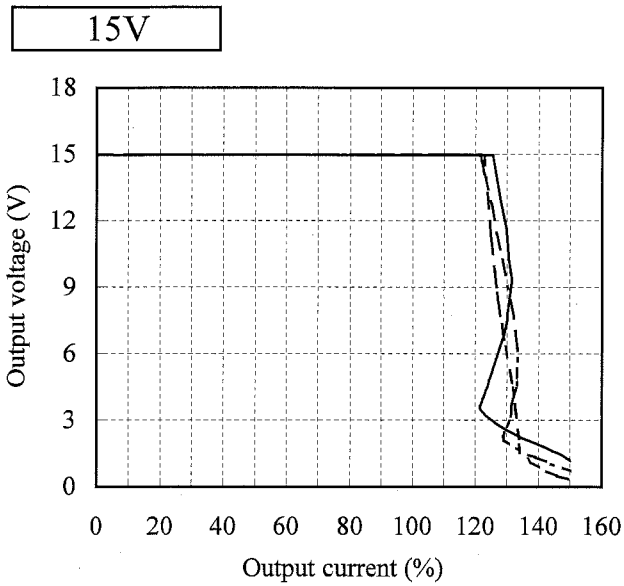

2.5 過電圧保護特性

Over voltage protection (OVP) characteristics

Conditions

$V_{in}$  : 110 VDC

$I_o$  : 0%

$T_{bp}$  : 25 °C

5V

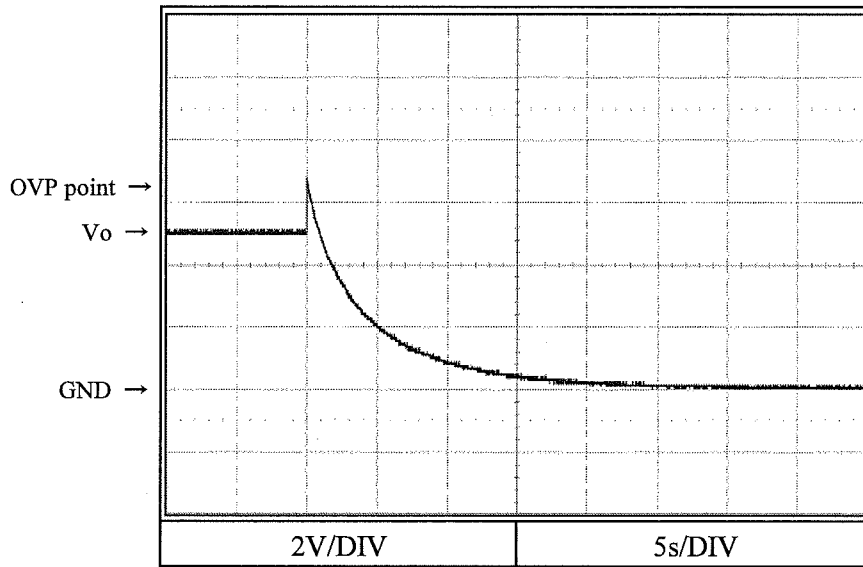

12V

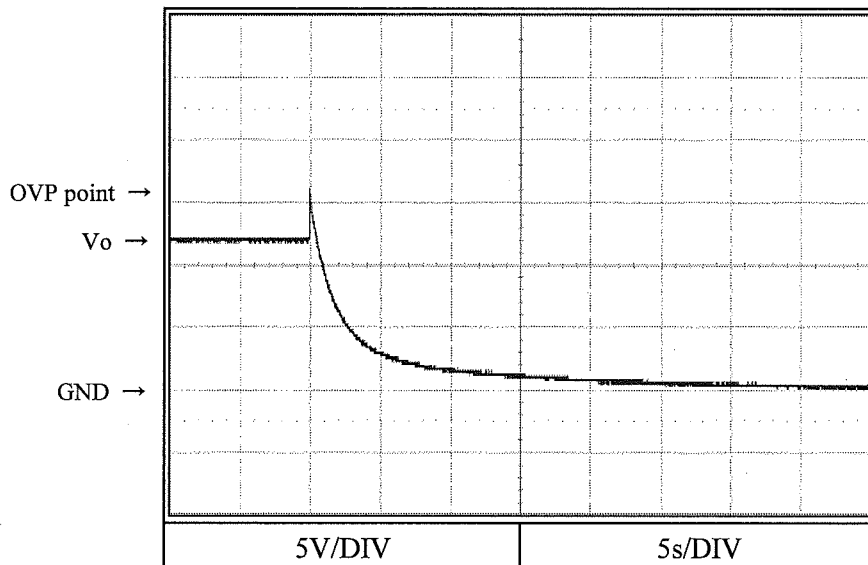



2.5 過電圧保護特性

Over voltage protection (OVP) characteristics

Conditions

Vin : 110 VDC

Io : 0%

Tbp : 25 °C

15V

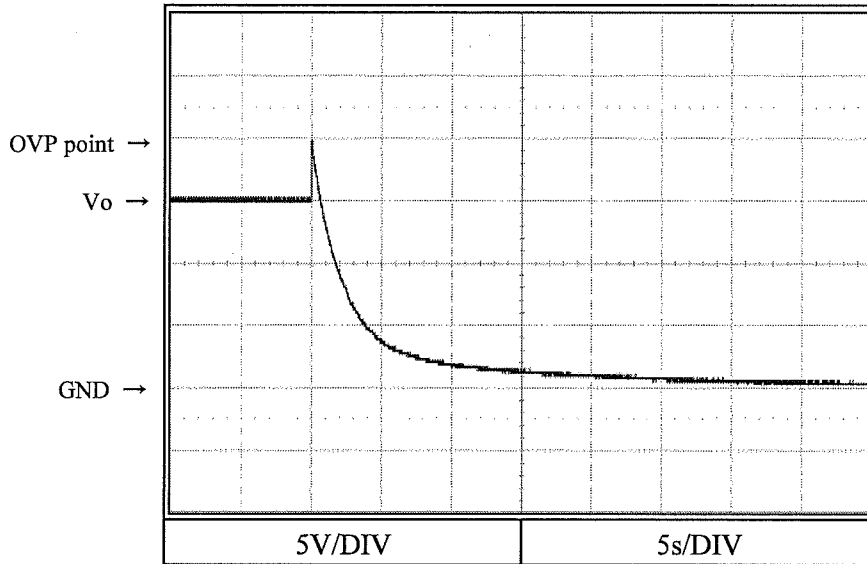

24V

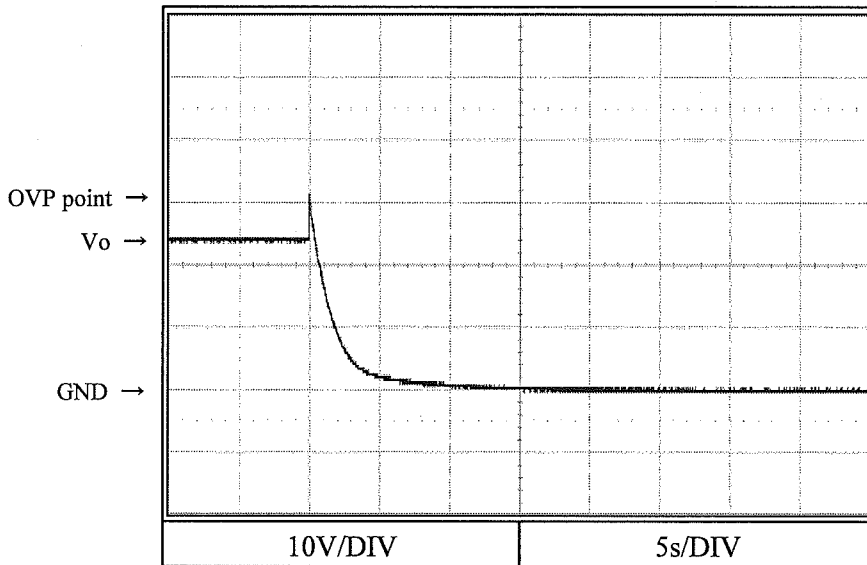

2.6 出力立ち上がり、立ち下がり特性  
Output rise and fall characteristics

Conditions

Vin : 110 VDC

Io : 0 %

Tbp : 25 °C

5V

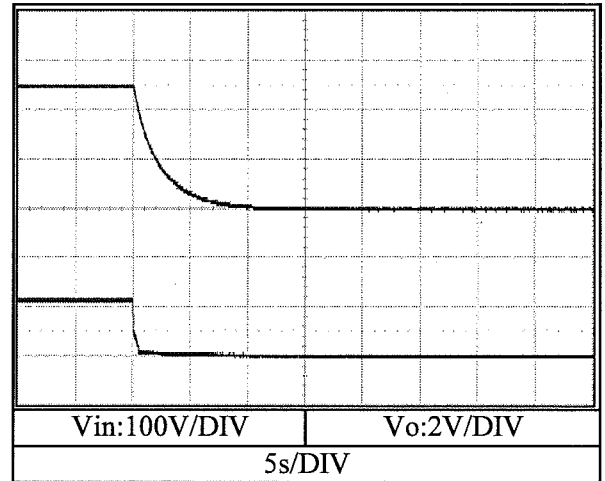
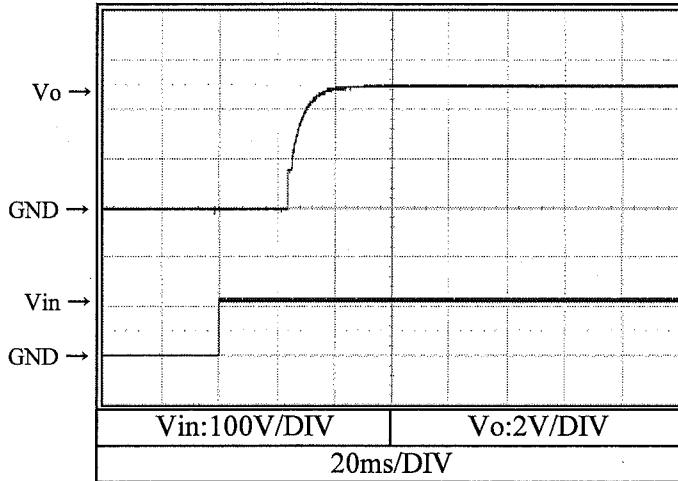

12V

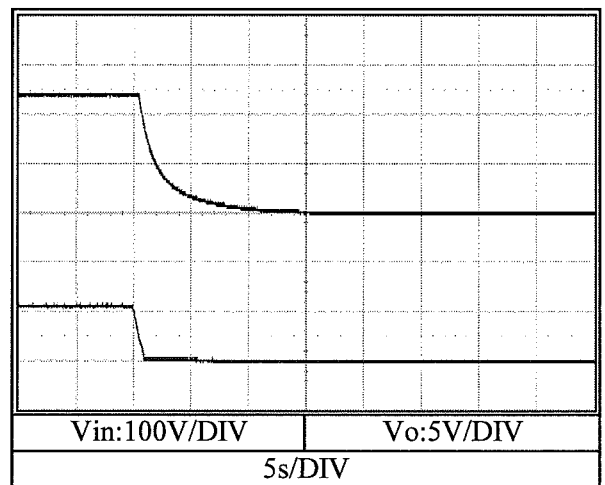
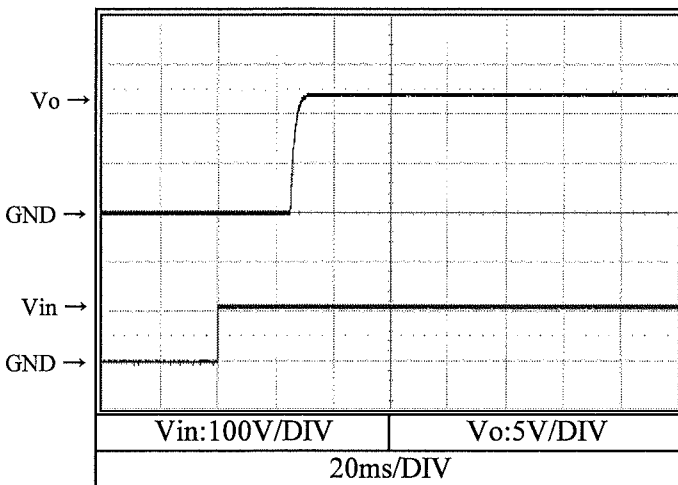

2.6 出力立ち上がり、立ち下がり特性  
Output rise and fall characteristics

Conditions Vin : 110 VDC  
Io : 0 %  
Tbp : 25 °C

15V

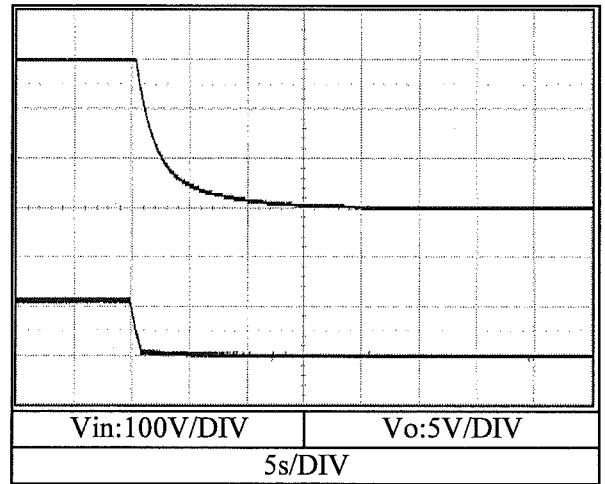
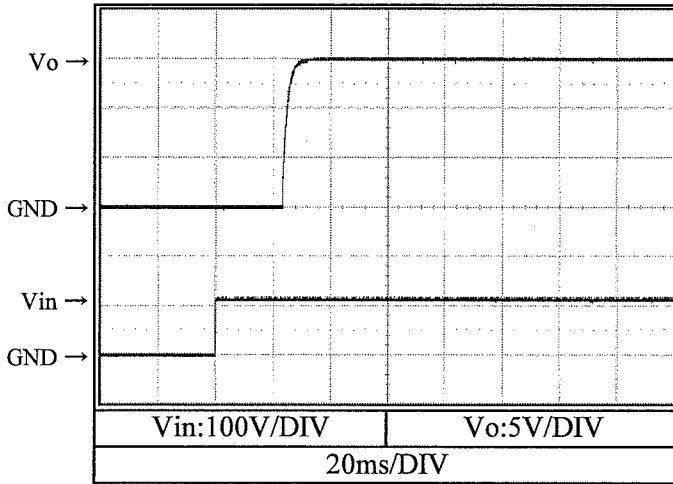

24V

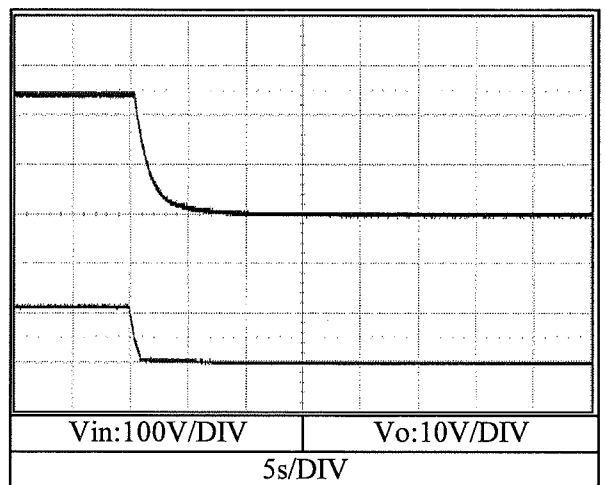
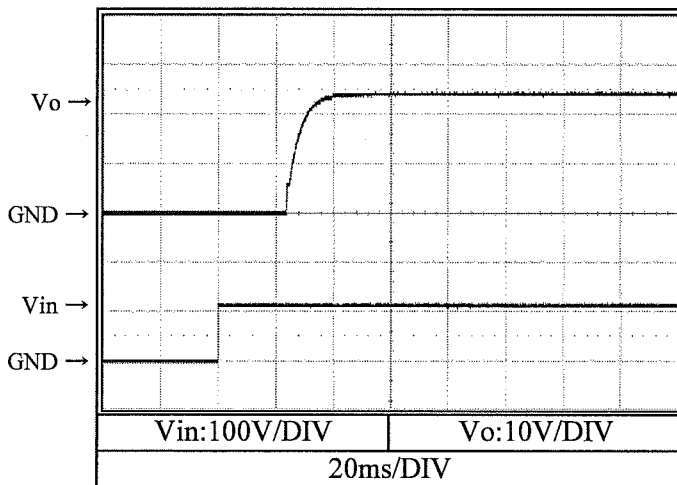

2.6 出力立ち上がり、立ち下がり特性  
Output rise and fall characteristics

Conditions Vin : 110 VDC  
Io : 100 %  
Tbp : 25 °C

5V

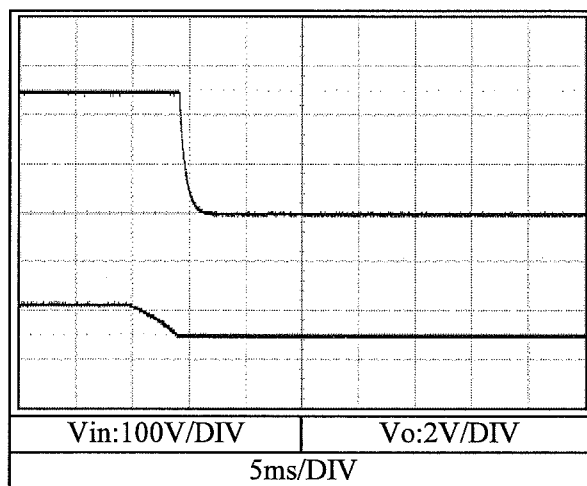
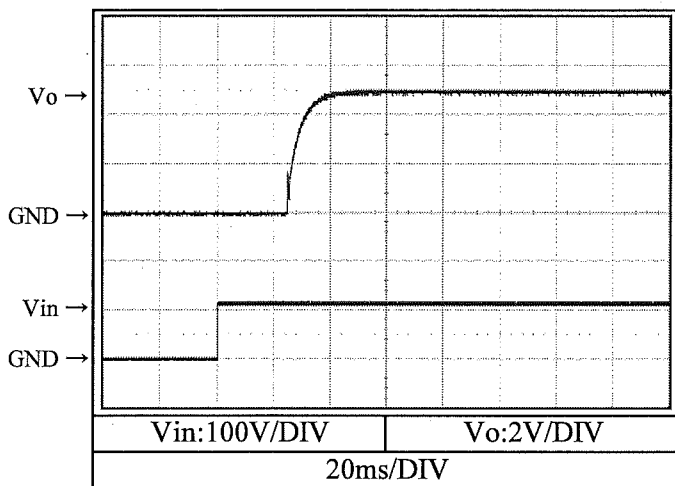

12V

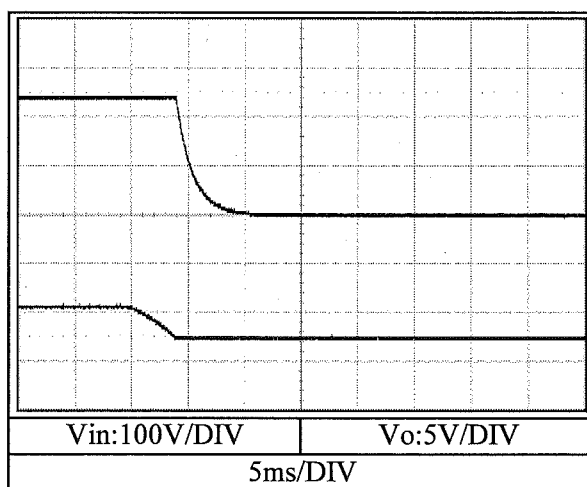
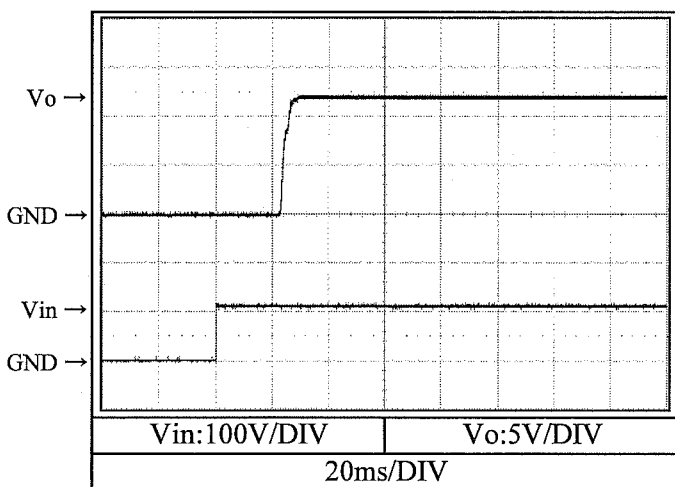

2.6 出力立ち上がり、立ち下がり特性  
Output rise and fall characteristics

Conditions Vin : 110 VDC  
Io : 100 %  
Tbp : 25 °C

15V

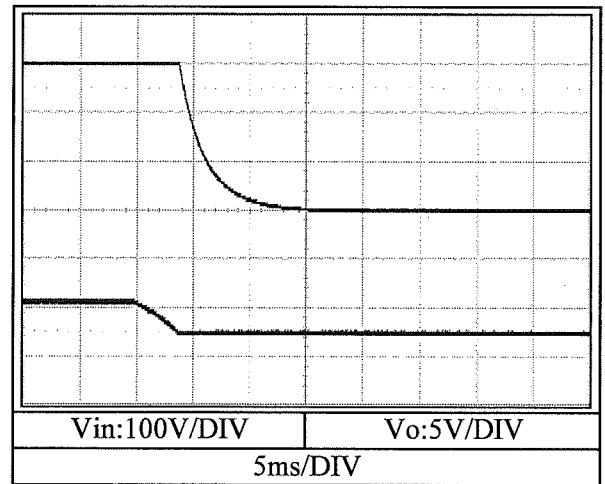
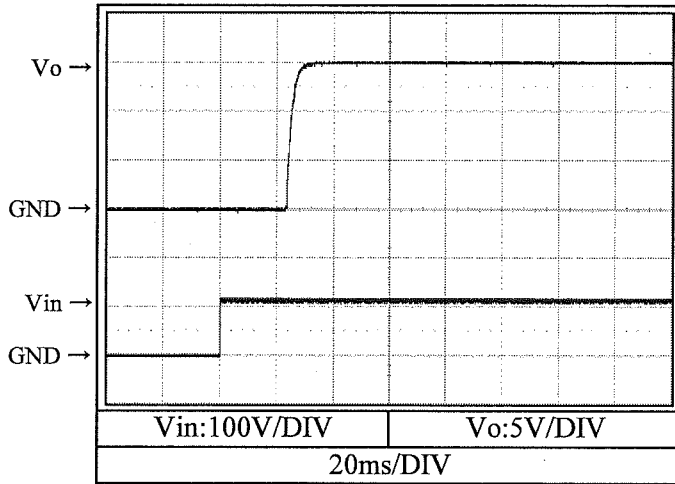

24V

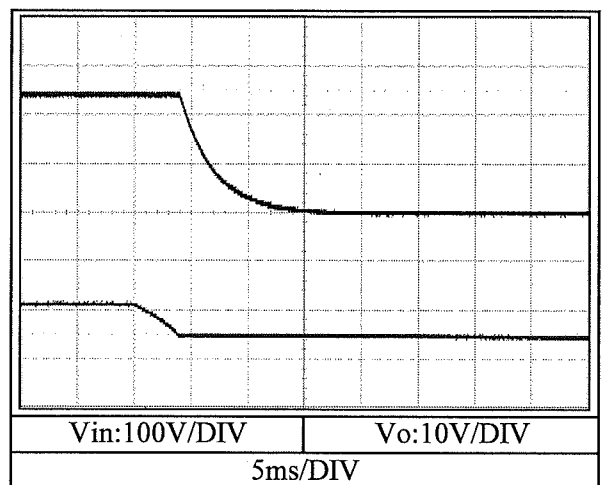
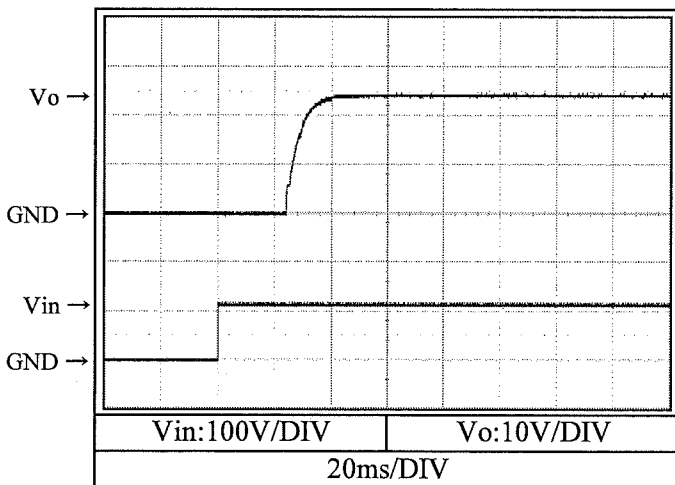

2.6 出力立ち上がり、立ち下がり特性 (ON/OFFコントロール時)

Output rise and fall characteristics with ON/OFF CONTROL

Conditions

Vin : 110 VDC

Io : 0 %

Tbp : 25 °C

5V

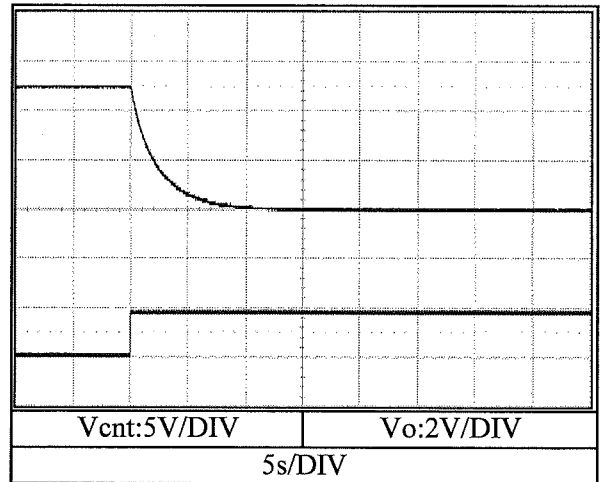
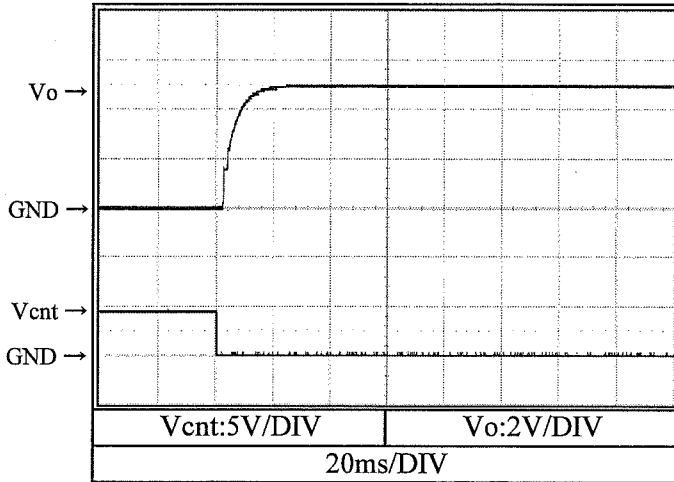

12V

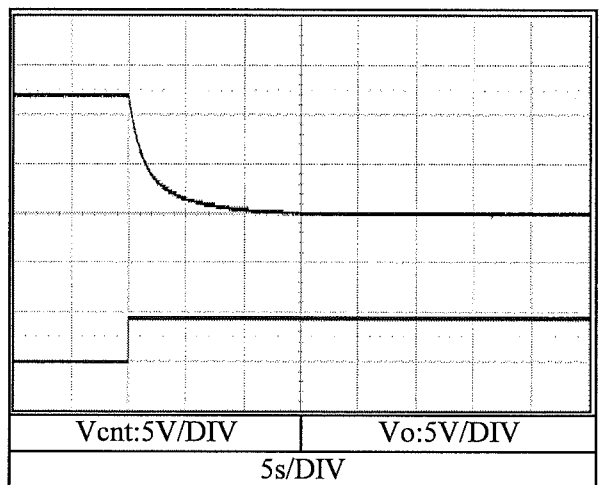
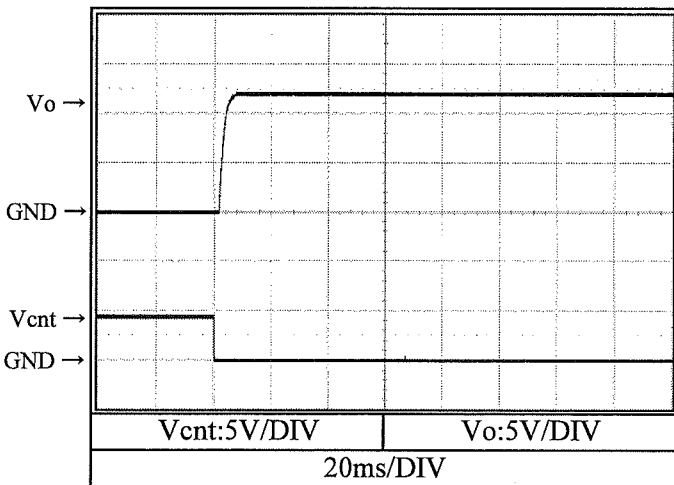

2.6 出力立ち上がり、立ち下がり特性 (ON/OFFコントロール時)

Output rise and fall characteristics with ON/OFF CONTROL

Conditions

Vin : 110 VDC

Io : 0%

Tbp : 25 °C

15V

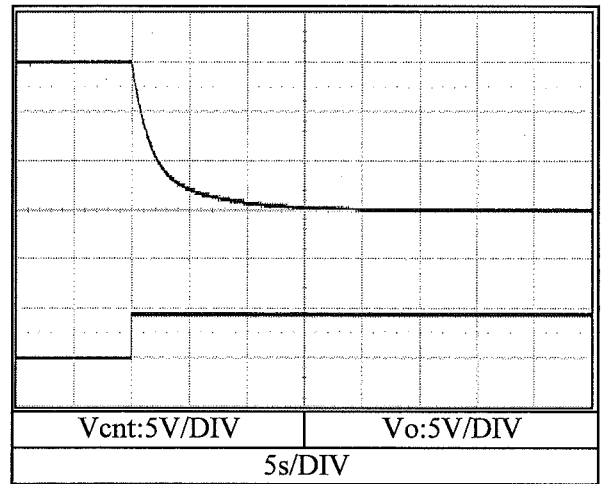
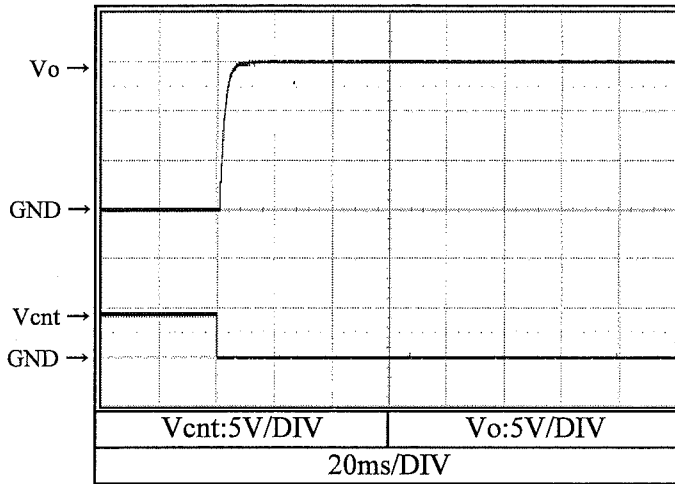

24V

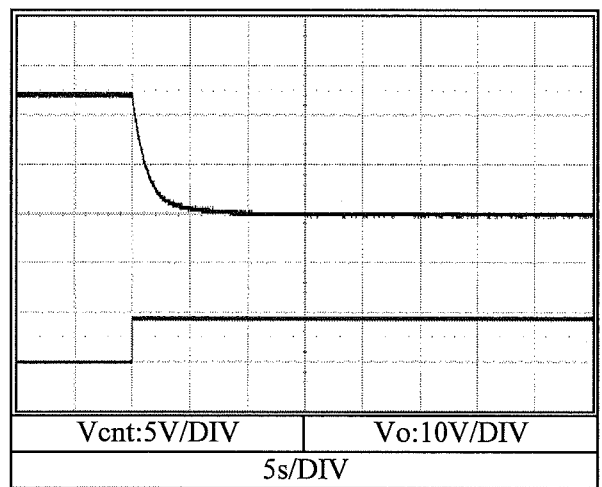
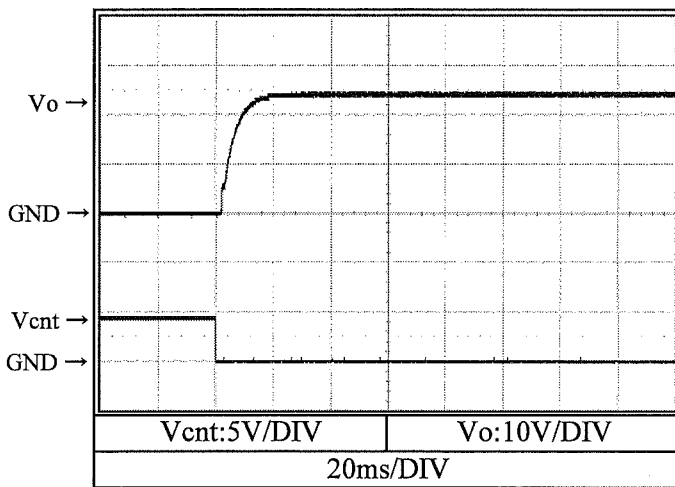

2.6 出力立ち上がり、立ち下がり特性 (ON/OFFコントロール時)

Output rise and fall characteristics with ON/OFF CONTROL

Conditions

Vin : 110 VDC

Io : 100 %

Tbp : 25 °C

5V

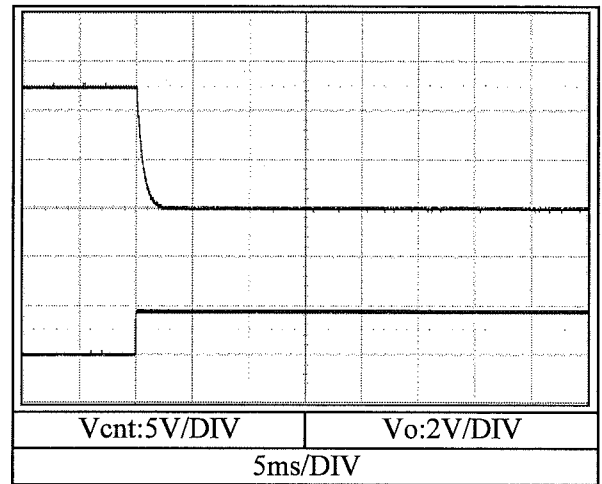
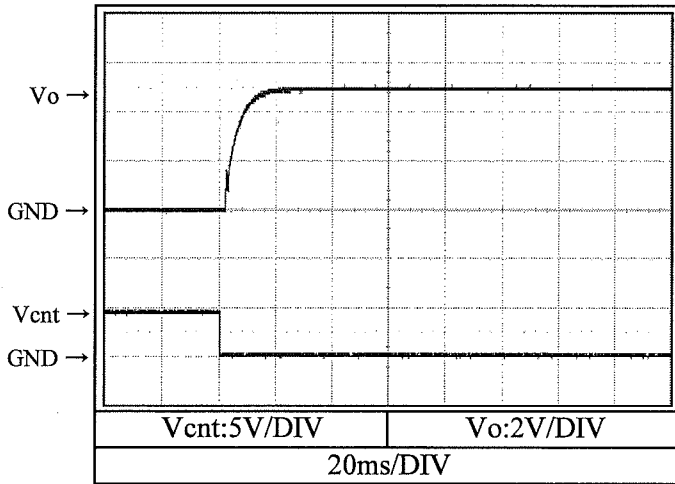

12V

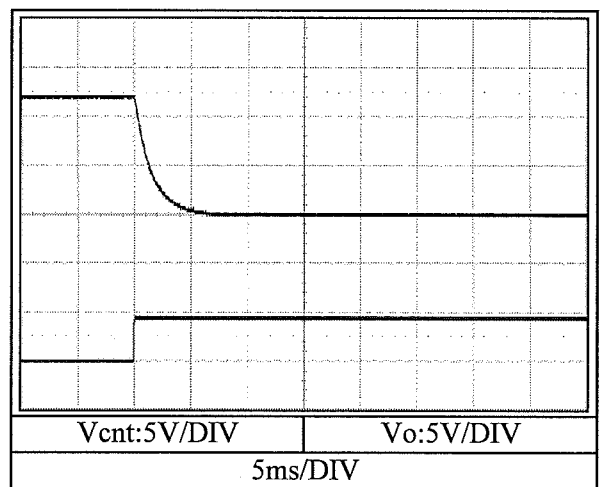
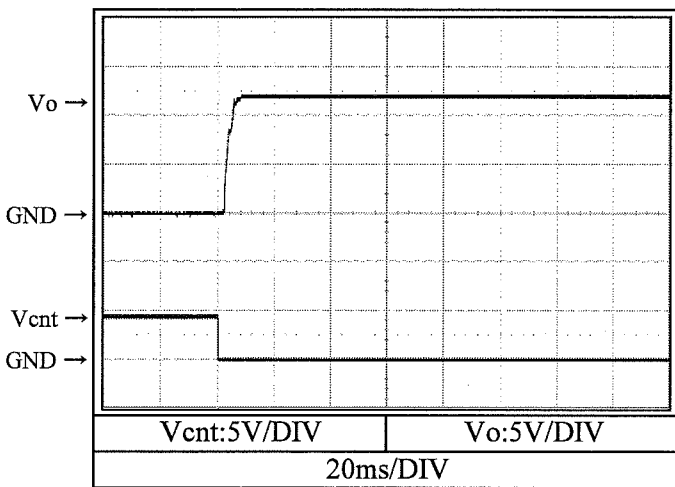



2.6 出力立ち上がり、立ち下がり特性 (ON/OFFコントロール時)

Output rise and fall characteristics with ON/OFF CONTROL

Conditions

Vin : 110 VDC

Io : 100 %

Tbp : 25 °C

15V

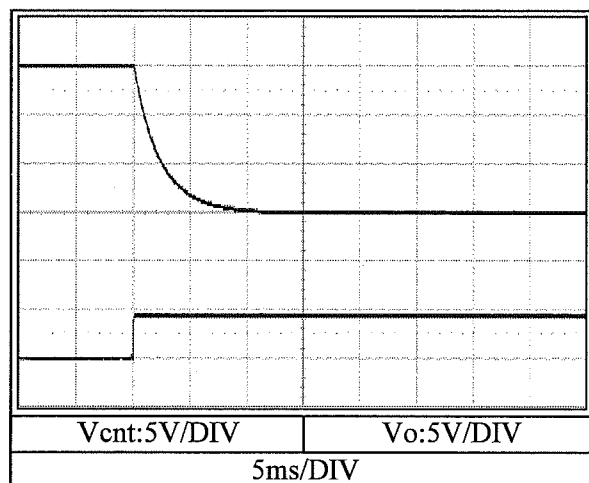
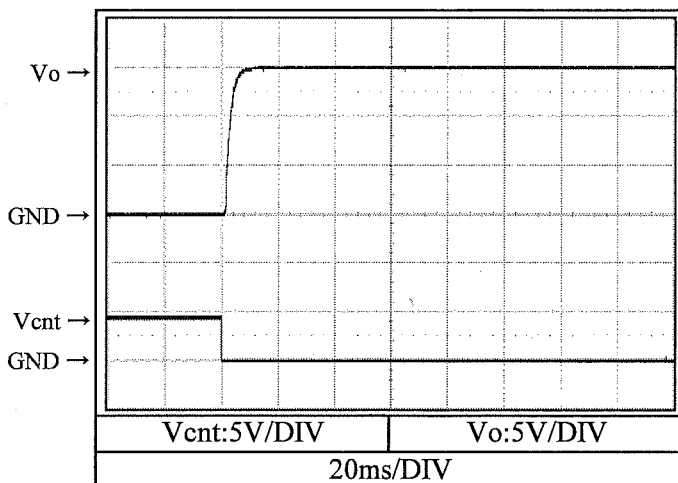

24V

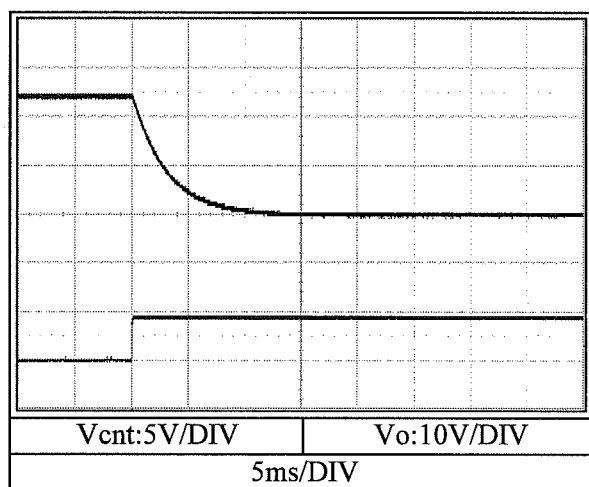
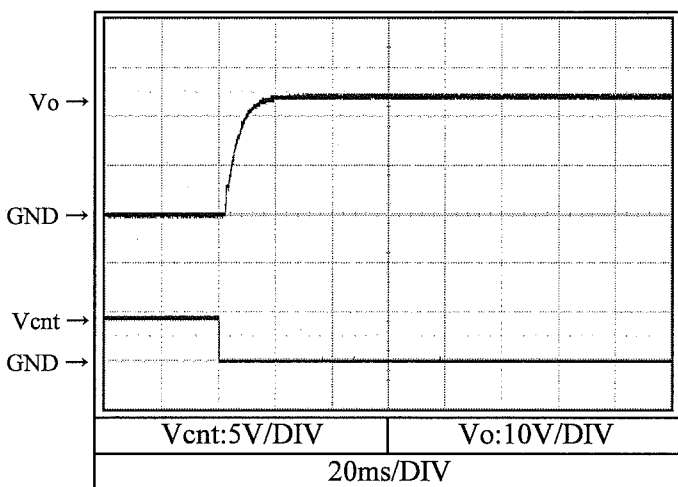

2.7 過渡応答（負荷急変）特性

Dynamic load response characteristics

Conditions

Vin : 110 VDC

Tbp : 25 °C

5V

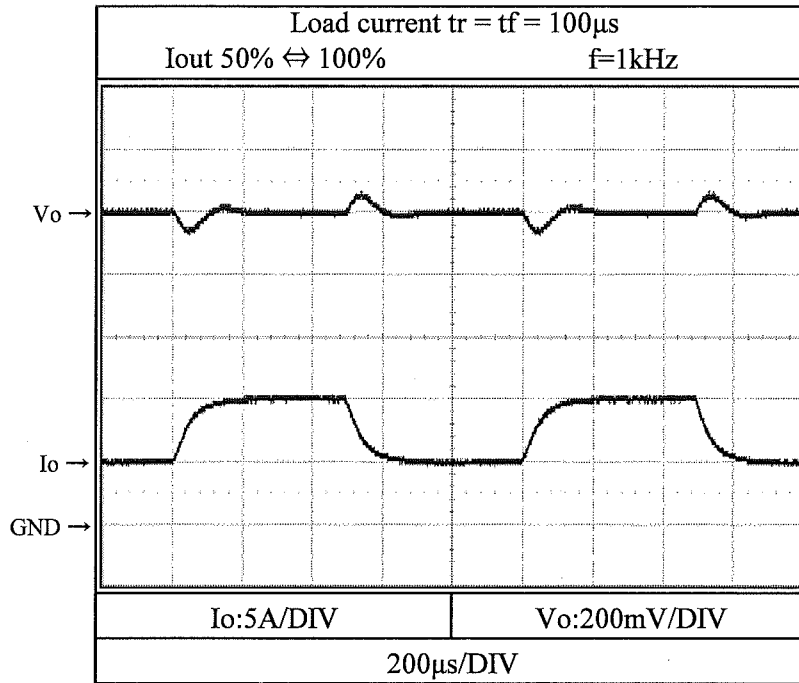

12V

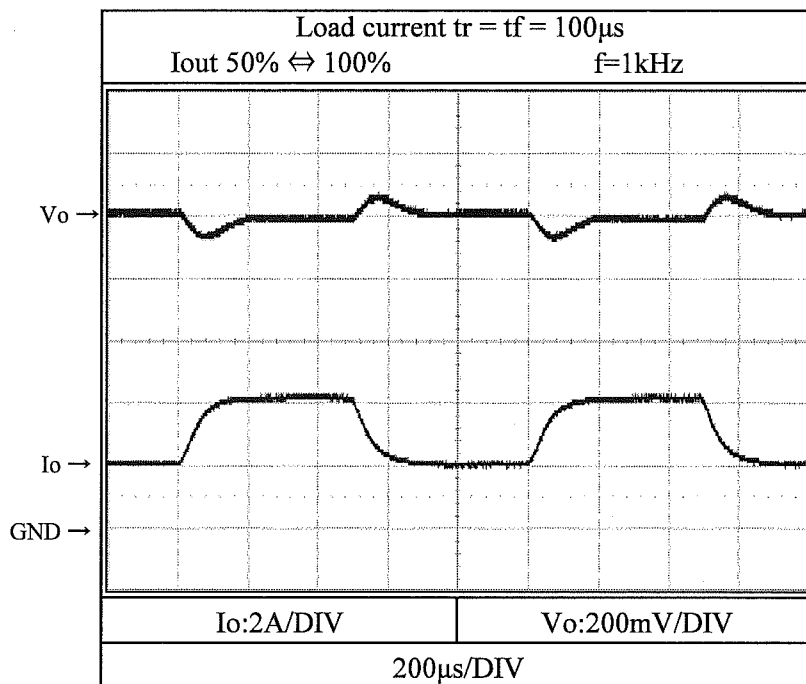

2.7 過渡応答（負荷急変）特性  
Dynamic load response characteristics

Conditions

Vin : 110 VDC

Tbp : 25 °C

15V

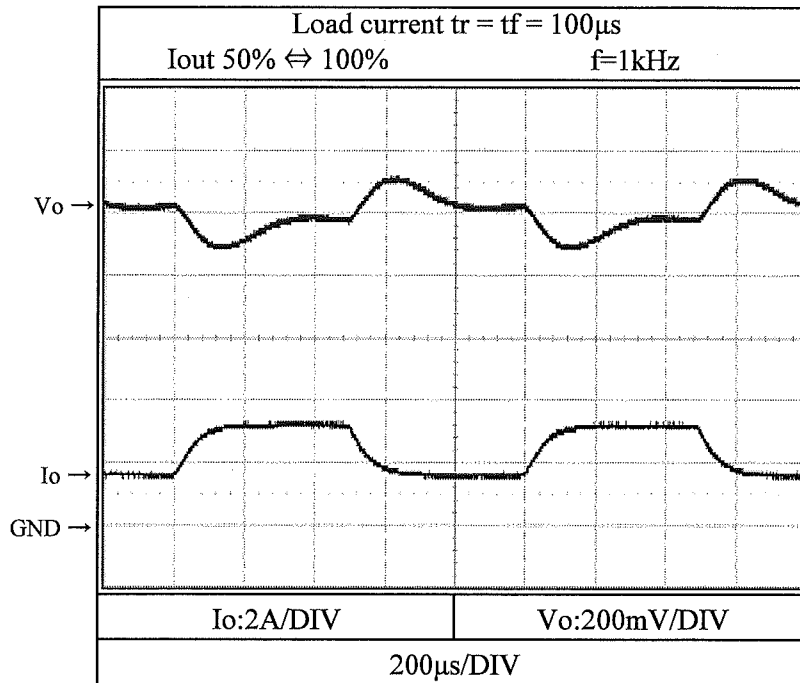

24V

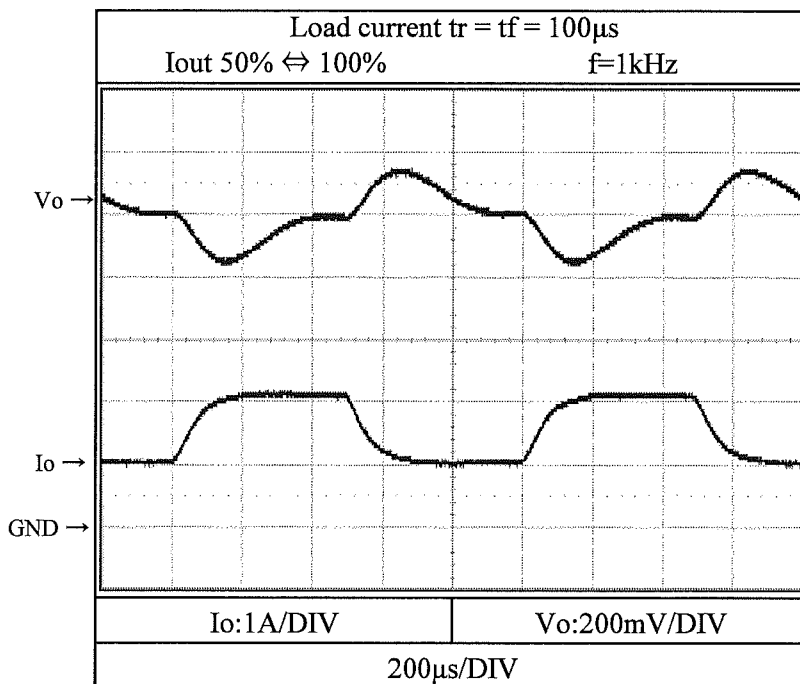

2.8 入力サージ電流 (突入電流) 特性  
Inrush current characteristics

Conditions

V<sub>in</sub> : 110 VDC  
I<sub>o</sub> : 100 %  
T<sub>bp</sub> : 25 °C

5V

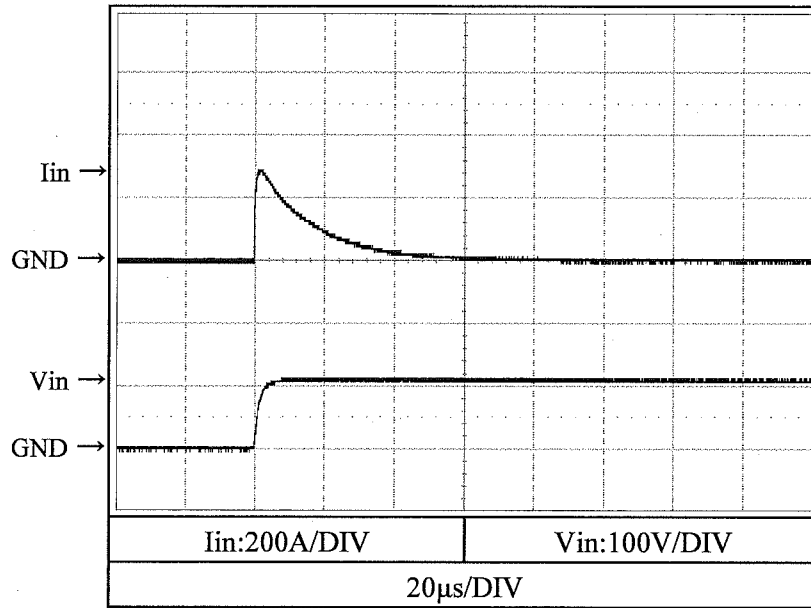

2.9 出力リップル、ノイズ波形  
Output ripple and noise waveform

Conditions

V<sub>in</sub> : 110 VDC  
I<sub>o</sub> : 100 %  
T<sub>bp</sub> : 25 °C

5V

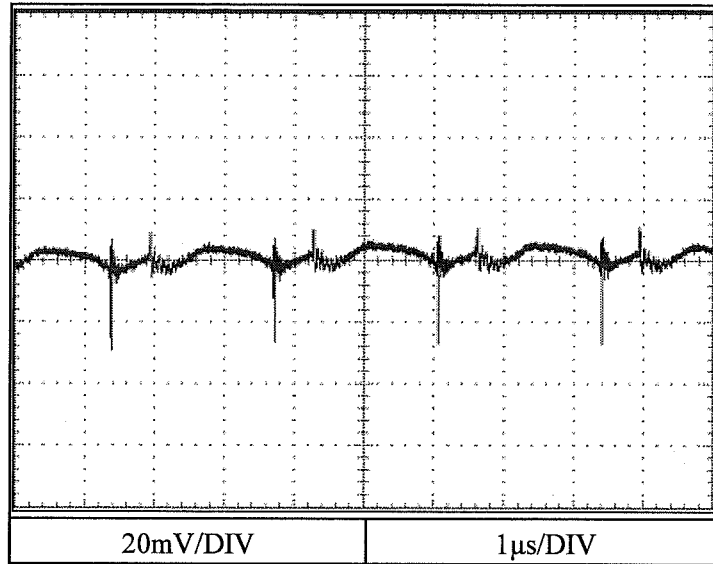

12V

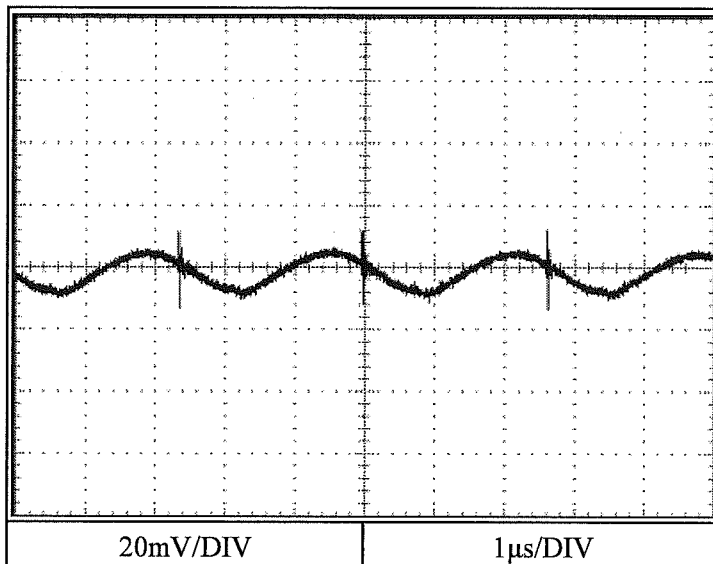

2.9 出力リップル、ノイズ波形  
Output ripple and noise waveform

Conditions

V<sub>in</sub> : 110 VDC  
I<sub>o</sub> : 100 %  
T<sub>bp</sub> : 25 °C

15V

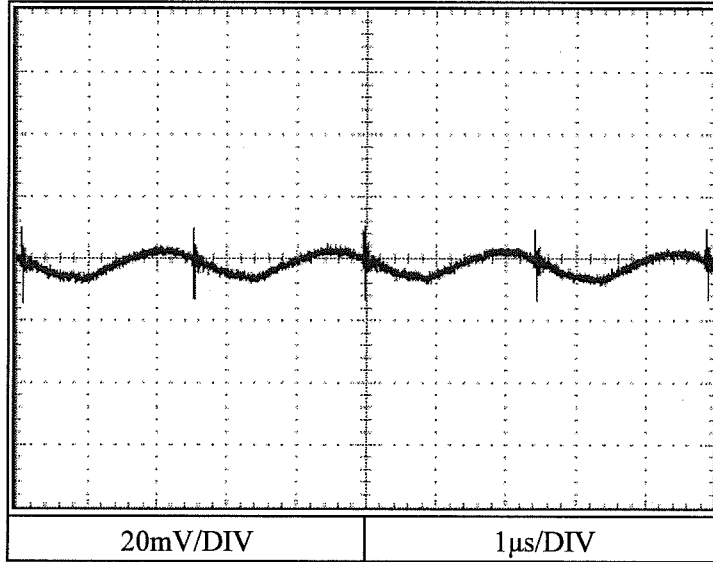

24V

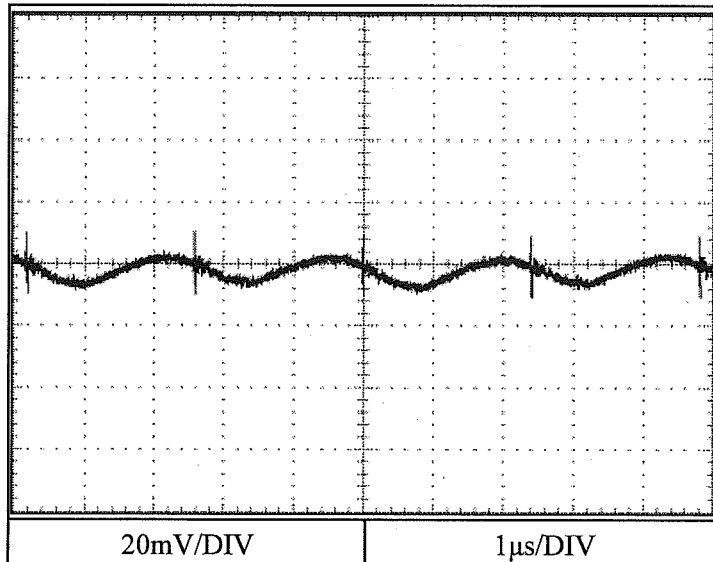

2.10 EMI特性

Electro-Magnetic Interference characteristics

(a) 雑音端子電圧 (帰還ノイズ)

Conducted Emission

Conditions

Vin : 110 VDC

Io : 100 %

Tbp : 25 °C

5V

+Vin

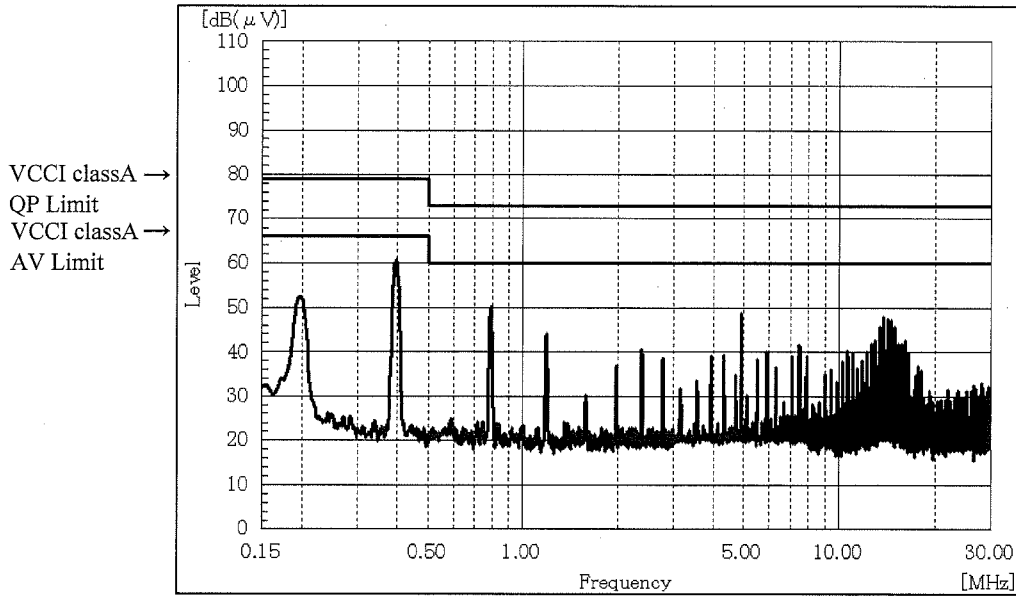

-Vin

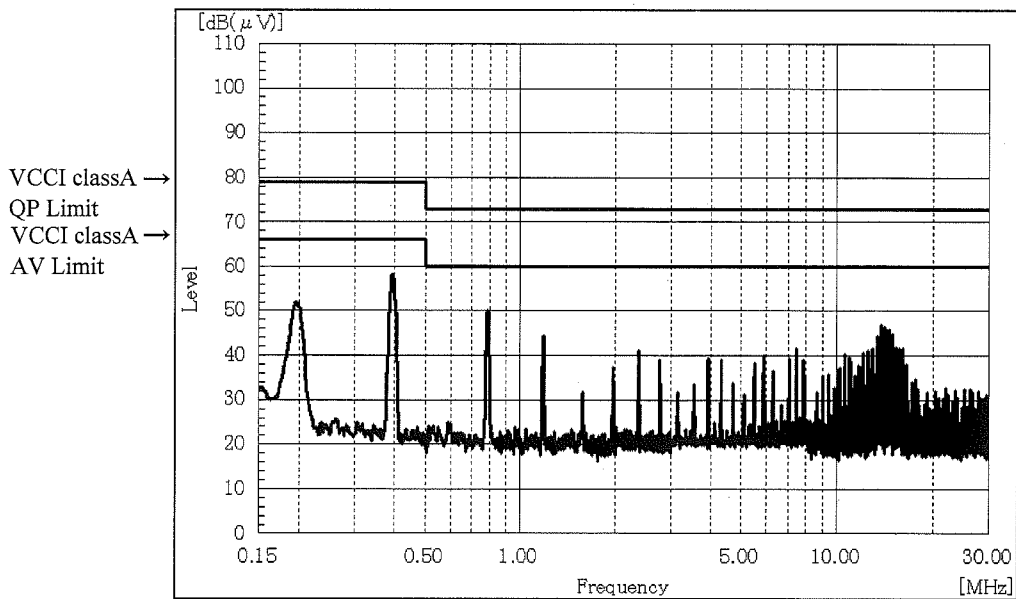

2.10 EMI特性

Electro-Magnetic Interference characteristics

(a) 雑音端子電圧 (帰還ノイズ)

Conducted Emission

Conditions

Vin : 110 VDC

Io : 100 %

Tbp : 25 °C

12V

+Vin

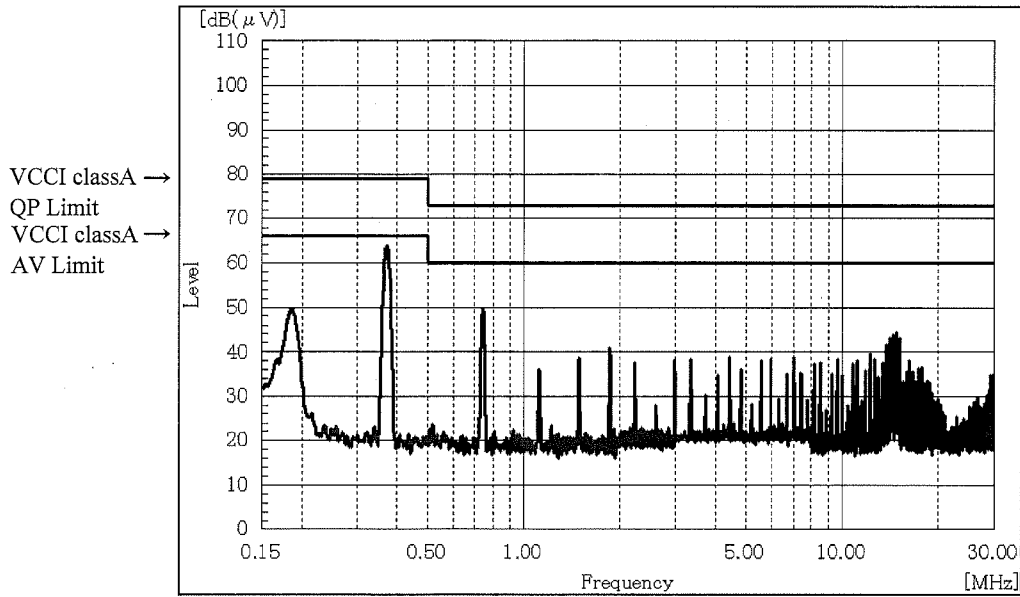

-Vin

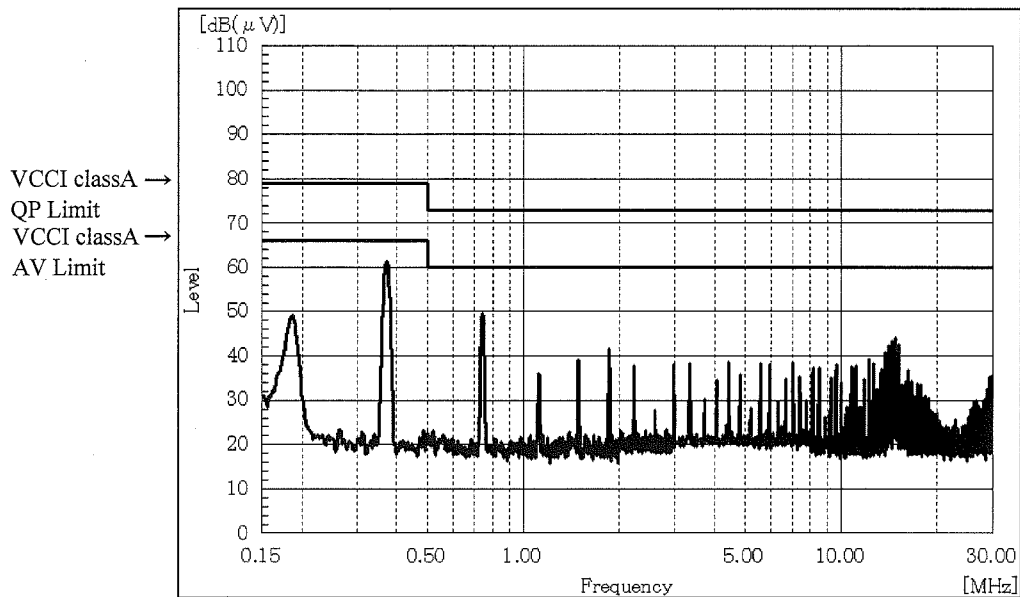



2.10 EMI特性

Electro-Magnetic Interference characteristics

(a) 雑音端子電圧 (帰還ノイズ)

Conducted Emission

Conditions

Vin : 110 VDC

Io : 100 %

Tbp : 25 °C

15V

+Vin

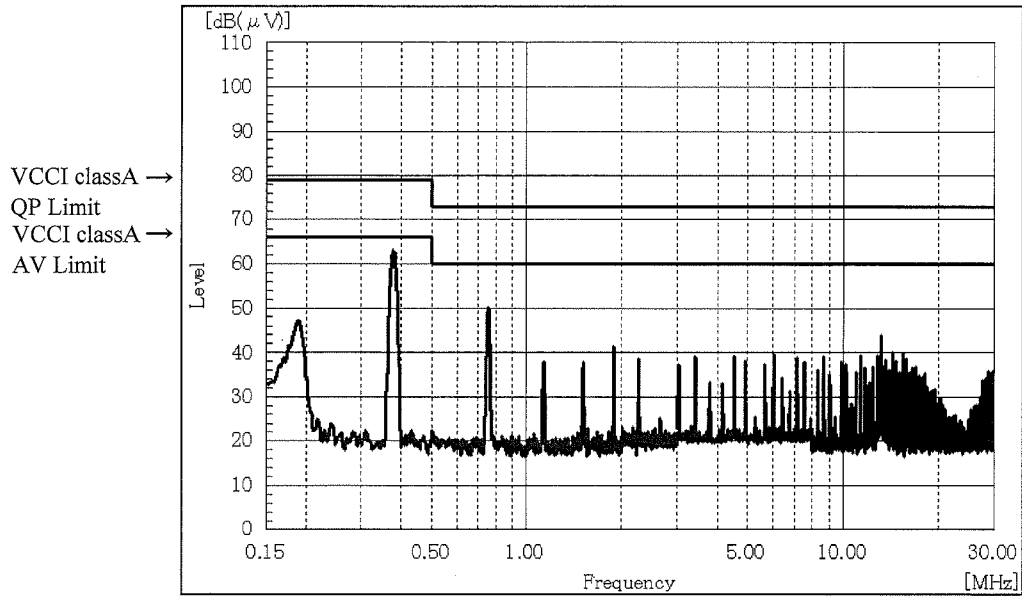

-Vin

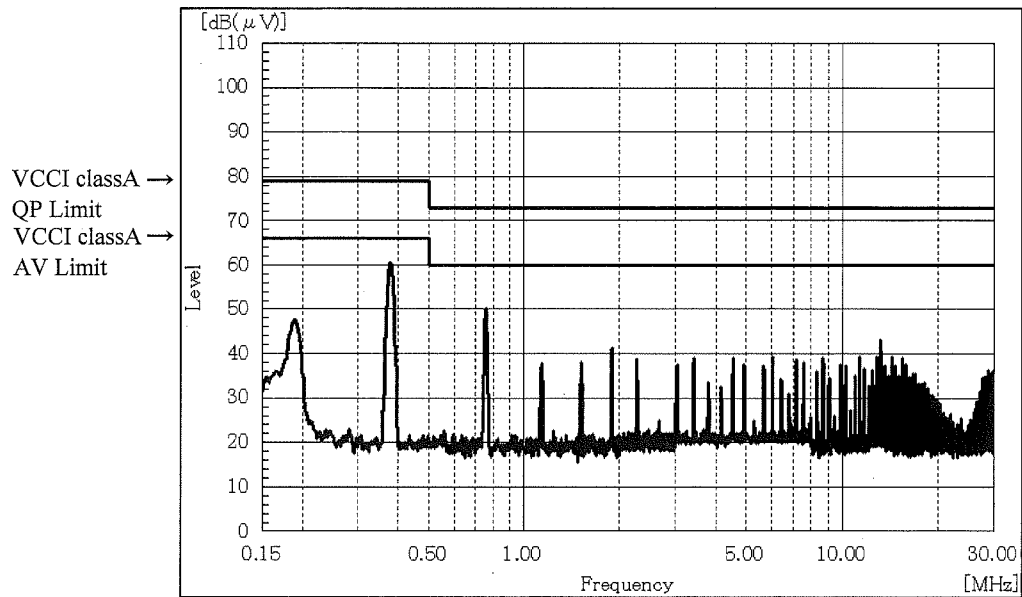

2.10 EMI特性

Electro-Magnetic Interference characteristics

(a) 雑音端子電圧 (帰還ノイズ)

Conducted Emission

Conditions

Vin : 110 VDC

Io : 100 %

Tbp : 25 °C

24V

+Vin

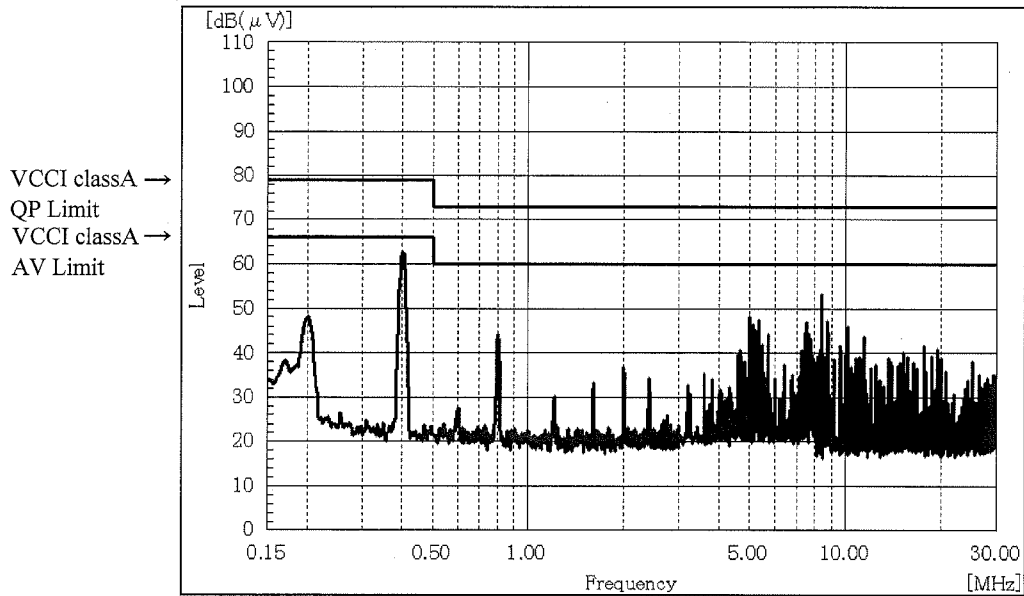

-Vin

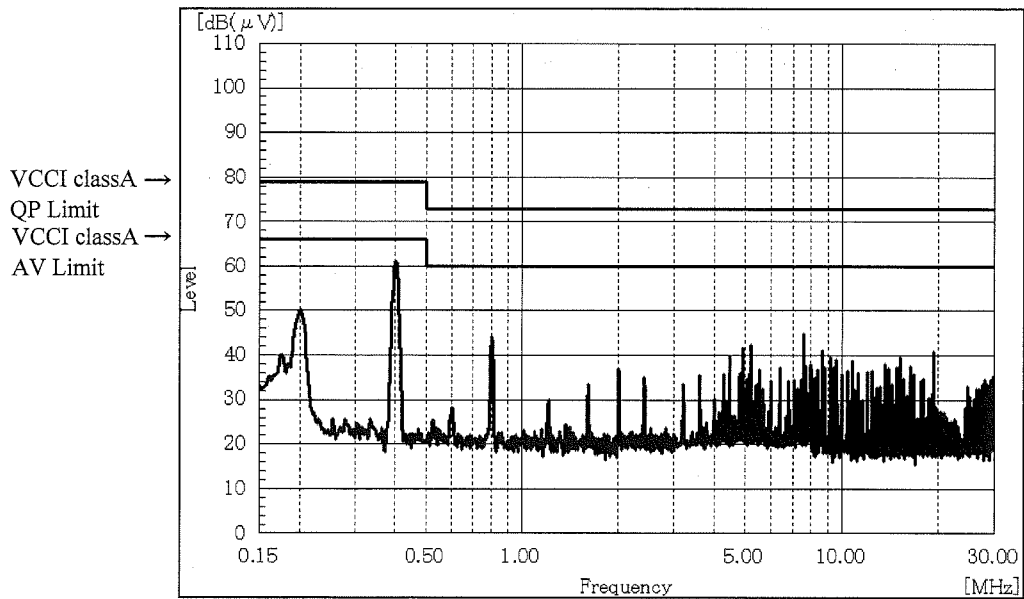

2.10 EMI特性

Electro-Magnetic Interference characteristics

(b) 雑音電界強度 (輻射ノイズ)

Radiated Emission

Conditions

Vin : 110 VDC

Io : 100 %

Tbp : 25 °C

5V

HORIZONTAL

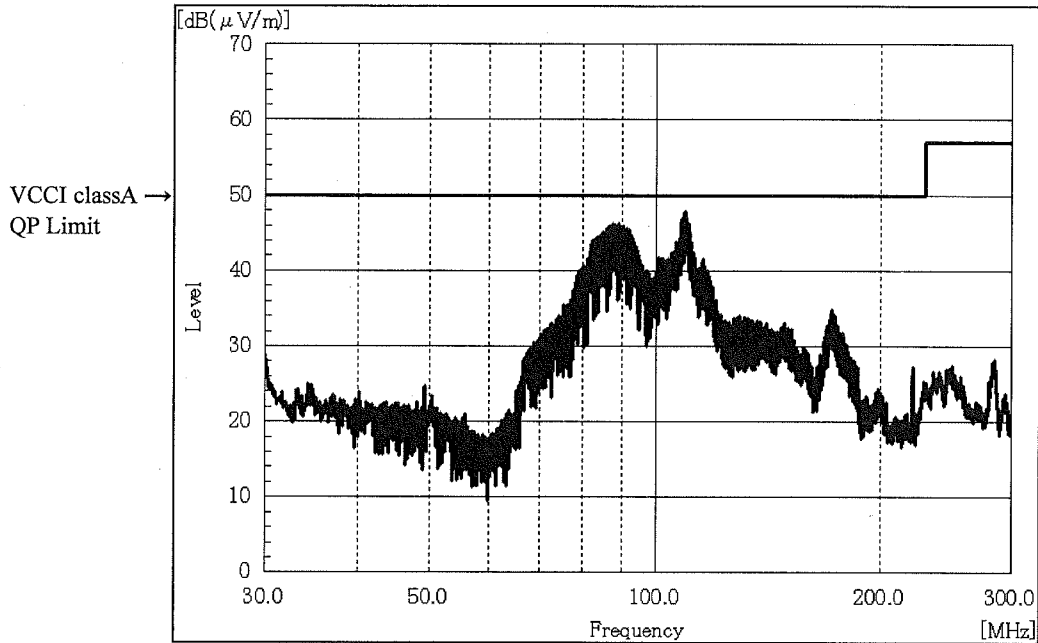

VERTICAL

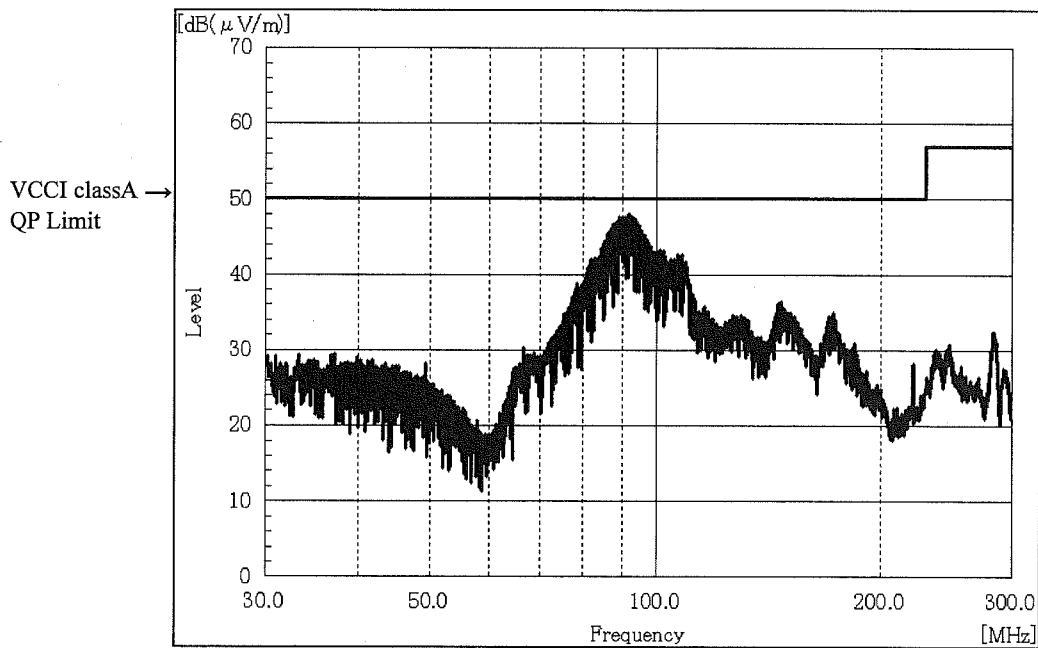

2.10 EMI特性

Electro-Magnetic Interference characteristics

(b) 雑音電界強度 (輻射ノイズ)

Radiated Emission

Conditions

Vin : 110 VDC

Io : 100 %

Tbp : 25 °C

12V

HORIZONTAL

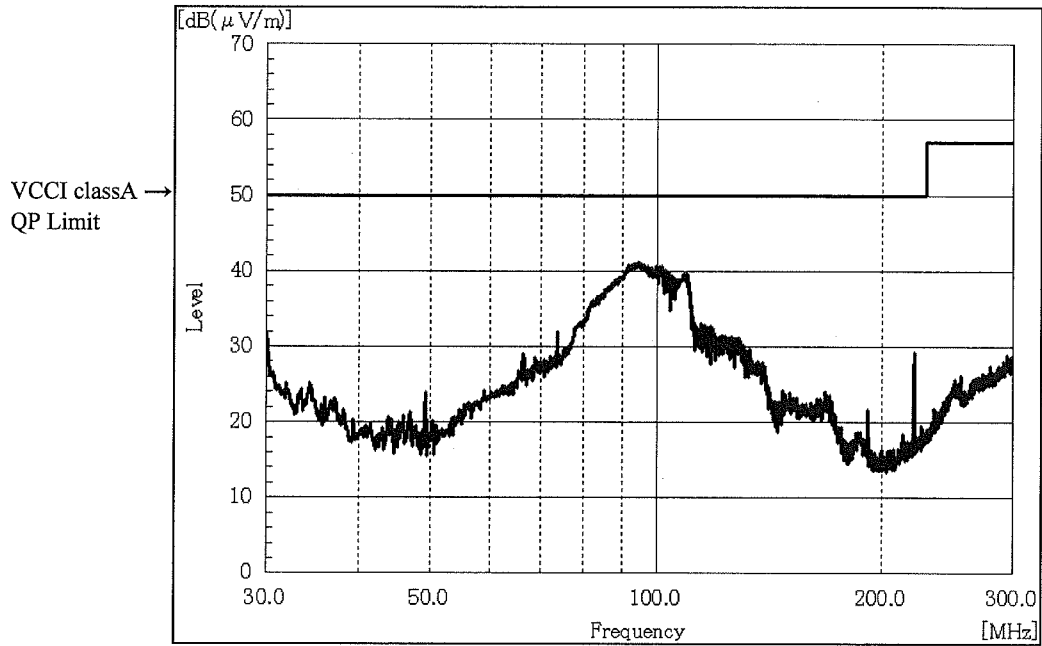

VERTICAL

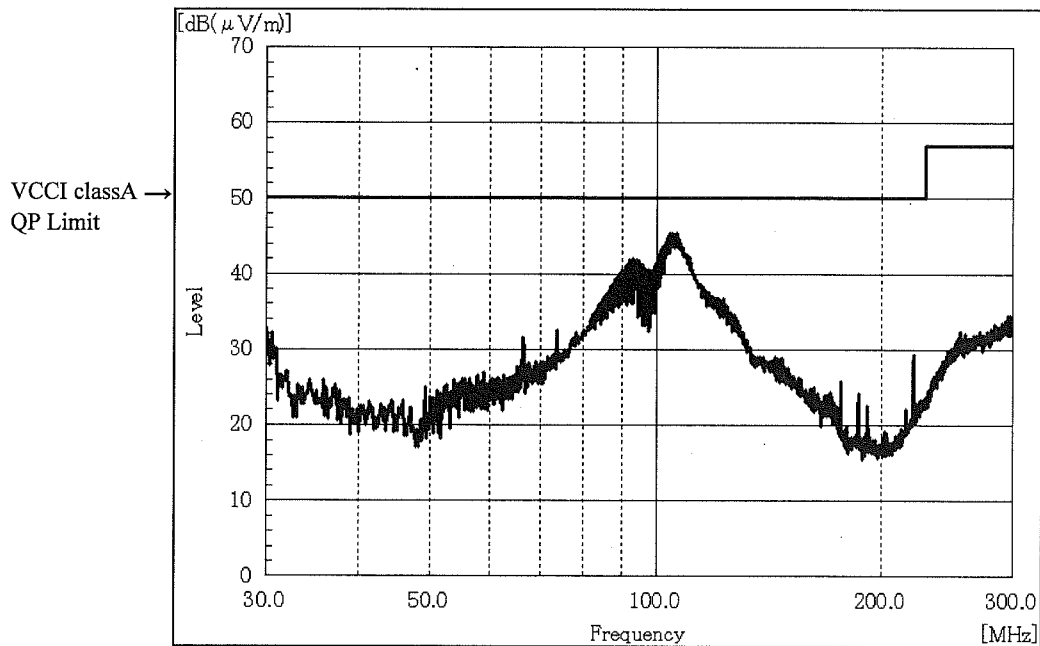

2.10 EMI特性

Electro-Magnetic Interference characteristics

(b) 雑音電界強度 (輻射ノイズ)

Radiated Emission

Conditions

Vin : 110 VDC

Io : 100 %

Tbp : 25 °C

15V

HORIZONTAL

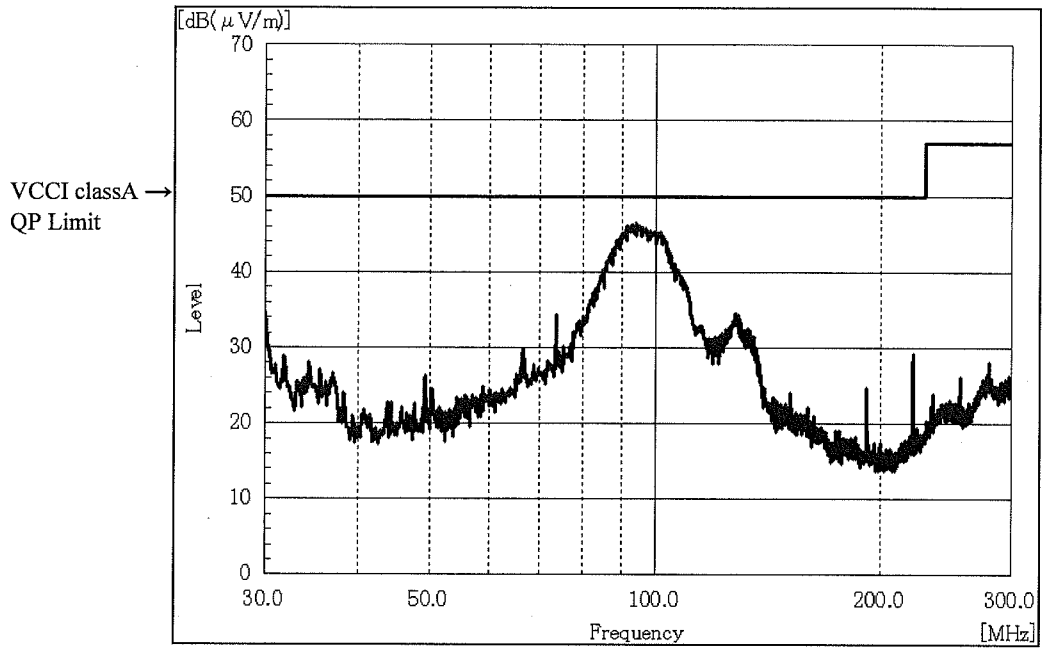

VERTICAL

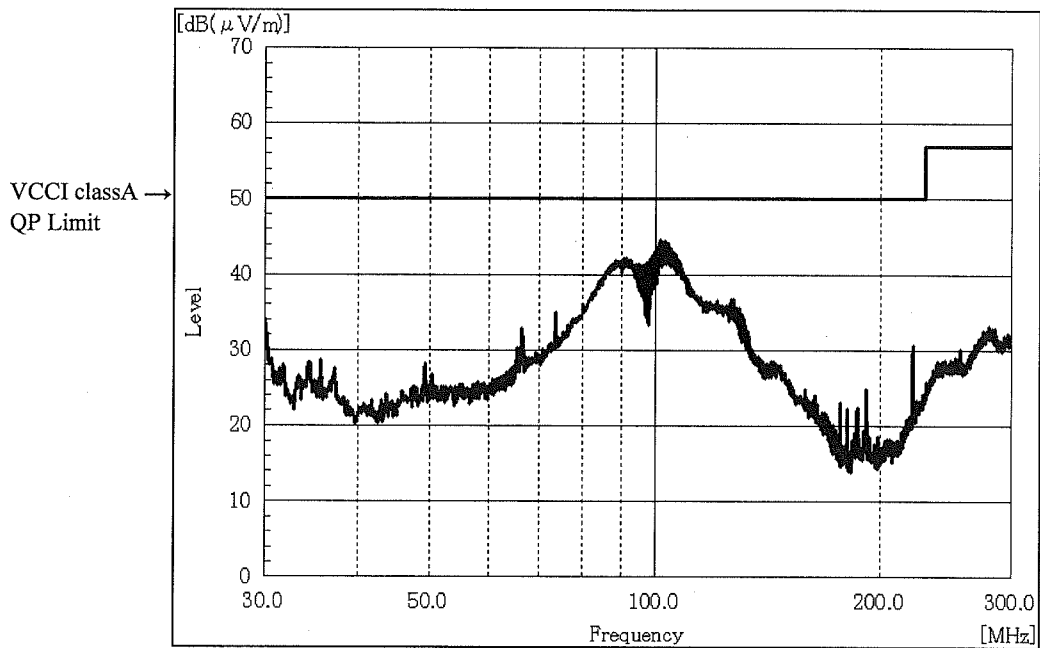

2.10 EMI特性

Electro-Magnetic Interference characteristics

(b) 雑音電界強度 (輻射ノイズ)

Radiated Emission

Conditions

Vin : 110 VDC

Io : 100 %

Tbp : 25 °C

24V

HORIZONTAL

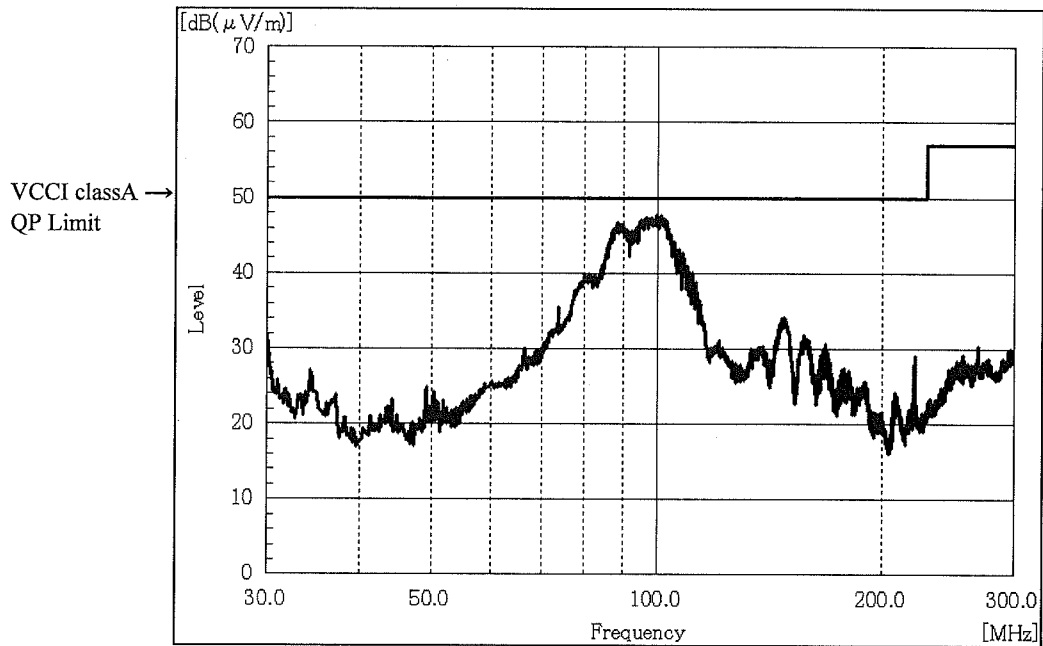

VERTICAL

