

iQK Series DC/DC Power Module Series

48-56V Input, 11.2V/90A/1008W High Current Quarter Brick

The iQK Series is a single output high power quarter brick that delivers up to 1008 Watts in a standard quarter brick package. With its high efficiency and exceptional thermal performance, the iQK Series is ideally suited for tight space, power-hungry intermediate bus architectures for datacom and telecommunication applications. The droop current sharing option allows multiple modules to be connected in parallel for higher power requirement. The monotonic start-up into a pre-bias output capability with synchronous rectification enhances product versatility.

Features

- Delivers up to 1008W / 90A
- High Efficiency ~97% typical at 70% Load
- Thermally enhanced bottom cooling
- Baseplate cooled
- Industry standard quarter brick footprint with dual output power pins
- Power Good signal
- High power density: > 560W / in³
- Fast Load Transient response
- 707 Vdc input to output isolation
- Negative Remote On/Off logic
- Monotonic start-up into a pre-biased load
- Fixed switching frequency
- Over temperature protection
- Over current protection
- Input undervoltage protection
- Latching over voltage protection
- UL/CSA/IEC/EN 62368-1, CE Mark

Optional Features

- Positive Remote On/Off logic
- Latched over-current protection
- Latched over-temperature protection
- Auto-recovery OVP
- 3.68 mm (0.145") Thru-hole pins
- Droop Load share for parallel operation

Ordering Information:

Product Identifier	Package Size	Platform	Input Voltage	Output Current	Output Units	Main Output Voltage	# of Outputs		Baseplate	Feature Set	RoHS Indicator
i	Q	K	4N	090	A	112	V	-	1	V9	-R
TDK Lambda	Quarter Brick	Grandeta	48-56V	090 – 90A	Amps	112 – 11.2V	Single		1 = Yes	See Option Table	R=RoHS Compliant

Option Table:

Baseplate + Feature Set	On/Off Logic	OVP	OCP and OTP	Droop Load Share	Pin Length	Base-plate	Special Feature
1U9	Negative	Latch	Non-Latch	Yes	0.16"	Yes	Thermal Enhancement
1V9	Negative	Latch	Non-Latch	No	0.16"	Yes	Thermal Enhancement

Product Offering:

Code	Input Voltage	Output Voltage	Output Current	Maximum Output Power	Efficiency
iQK4N090A112V	48-56V*	11.2V	90A	1008W	96%

The module can be operated down to 45V input, but the output voltage regulation will be out of spec.

Mechanical Specification:

Dimensions are in mm [in]. Unless otherwise specified tolerances are: $x.x \pm 0.5$ [0.02], $x.xx$ and $x.xxx \pm 0.25$ [0.010]

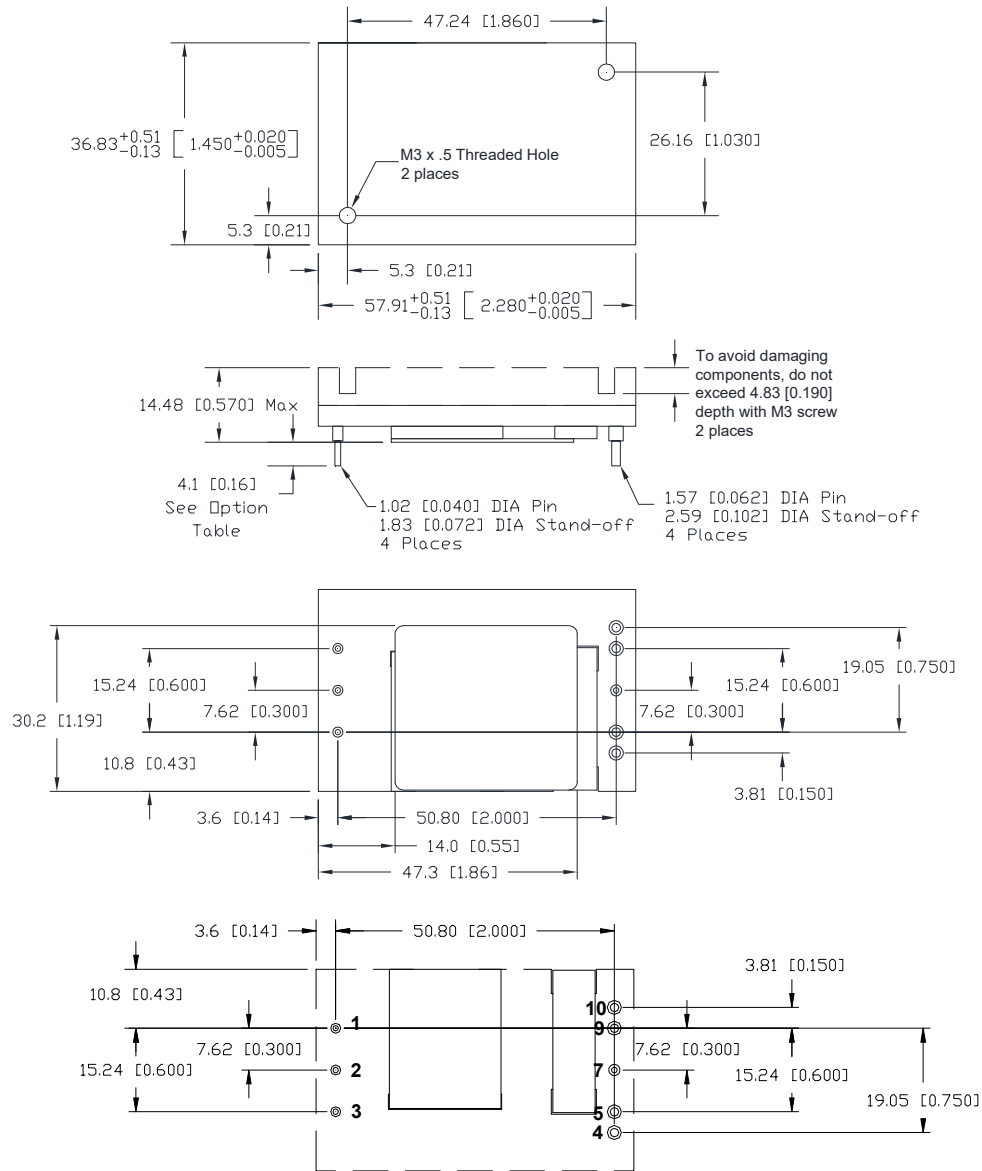

Recommended hole pattern (top view)

Pin Assignment:

PIN	FUNCTION	PIN	FUNCTION
1	Vin (+)	6	N/A
2	On/Off	7	Power Good
3	Vin (-)	8	N/A
4	Vout (-)	9	Vout (+)
5	Vout (-)	10	Vout (+)

Pin base material is copper with gold plating. The maximum module weight is 90g.

Absolute Maximum Ratings:

Stresses in excess of Absolute Maximum Ratings may cause permanent damage to the device.

Characteristic	Min	Max	Unit	Notes & Conditions
Continuous Input Voltage	-0.5	60	Vdc	
Transient Input Voltage	---	80	Vdc	100ms max.
Isolation Voltage Input to Output	---	707	Vdc	
Storage Temperature	-55	125	°C	
Operating Temperature Range (Tc)	-40	119	°C	Measured at the location specified in the thermal measurement figure. Maximum temperature varies with model number, output current, and module orientation

Input Characteristics:

Unless otherwise specified, specifications apply over all Rated Input Voltage, Resistive Load, and Temperature conditions.

Characteristic	Min	Typ	Max	Unit	Notes & Conditions
Operating Input Voltage	48	52	56	Vdc	When $45V \leq V_{in} \leq 48V$, the module will continue to operate, but the output voltage regulation may be out of spec. $V_{o_min} > 10.2V$ at $45V_{in}$ and 100% load
Maximum Input Current	---	---	22.5	A	$V_{in} = 0$ to $V_{in,max}$, $I_o = I_{o,max}$, $V_o = V_{o,nom}$
Turn-on Voltage	---	46.3	---	Vdc	
Turn-off Voltage	---	43.6	---	Vdc	
Hysteresis	---	2.7	---	Vdc	
Startup Delay Time from application of input voltage	---	16	---	ms	$V_o = 0$ to $0.1 * V_{o,nom}$; On/Off = On, $I_o = I_{o,max}$, $T_c = 25^\circ C$
Startup Delay Time from On/Off	---	14	---	ms	$V_o = 0$ to $0.1 * V_{o,nom}$; $V_{in} = V_{i,nom}$, $I_o = I_{o,max}$, $T_c = 25^\circ C$
Output Voltage Rise Time	---	9.5	---	ms	$I_o = I_{o,max}$, $T_c = 25^\circ C$, $V_o = 0.1$ to $0.9 * V_{o,nom}$
Inrush Current	---	---	0.1	A ² s	Exclude external input capacitors
Input Reflected Ripple	---	124	---	mApp	See input/output ripple and noise measurements figure; BW = 20 MHz
Input Ripple Rejection	---	30	---	dB	@120Hz

Caution: The power modules are not internally fused. An external input line fast blow fuse with a maximum value of 30A is required; see the Safety Considerations section of the data sheet.

Electrical Data: iQK4N090A112V-1xx: 11.2V, 90A, 1008W Output

Characteristic	Min	Typ	Max	Unit	Notes & Conditions
Output Voltage Initial Set Point (No Load)	11.09	11.2	11.31	Vdc	Vin = Vin,nom; Io = 0; Tc = 25 °C
Output Voltage Tolerance	10.98	11.1	11.42	Vdc	Over all rated input voltage and temperature conditions to end of life (exclude the droop)
Efficiency at 75% Load (750W) **	---	97	---	%	Vin = Vin,min, Io = 80% of Io,max, Tc = 25 °C
Efficiency at 100% Load (1008W) **	---	96.5	---	%	Vin = Vin,nom; Io = Io,max; Tc = 25 °C
Line Regulation	---	30	60*	mV	Vin = Vin,min to Vin,max, Io = 50% of Io,max and Tc = 25 °C
Load Regulation	---	30	80*	mV/A	Vin = Vin,nom, Io = Io,min to Io,max, Tc = 25 °C
Temperature Regulation	---	100	250*	mV	Tc = Tc,min to Tc,max, Vin = Vin,nom, and Io = 50% of Io,max
Load Share Accuracy (optional)	-10	---	+10	%	50% to 100% of total paralleling system maximum load current, Tc = 25 °C. Guaranteed by design.
Output Current	0	---	90	A	At Io < 25% of Io,max, the step load transient performance may degrade slightly
Output Current Limiting Threshold	92	99	---	A	Vo = 0.9*Vo,nom, Tc < Tc,max
Short Circuit Current	---	2	---	A	Vo = 0.25V, Tc = 25 °C (hiccup mode)
Output Ripple and Noise Voltage	---	170	---	mVpp	Vin = Vin,nom, Io ≥ Io,min, Tc = 25 °C. Measured across one 0.1 μF, one 1.0 μF, and one 47 μF ceramic capacitors, and two 470 μF plus one 680 μF electrolytic capacitors located 2 inches away – see Input/Output ripple measurement figure; BW = 20MHz
	---	16	---	mVrms	
Output Voltage Adjustment Range	---	---	---	%Vo,nom	N/A
Dynamic Response:					di/dt = 0.1A/μs, Vin = Vin,nom; load step from 50% to 75% of Io,max, Tc = 25 °C with at least one 1.0 μF, four 10 μF ceramic capacitors, two 470 μF and one 680 μF electrolytic capacitors across the output terminals
Recovery Time to 10% of Peak Deviation	---	400	---	μs	Note: Exclude the droop.
Transient Voltage	---	200	---	mV	
Output Voltage Overshoot during startup	---	0	---	mV	Vin = Vin,nom; Io = Io,max, Tc = 25 °C
Switching Frequency	---	132	---	kHz	Fixed
Output Over-voltage Protection	12.9*	13.3	14.0*	V	
External Load Capacitance	1,600	---	8,000 †	μF	Cext,min required for the 100% load dump. Minimum ESR > 2 mΩ
Isolation Capacitance	---	700	---	pF	
Isolation Resistance	15	60	---	MΩ	
Power Good Pin	---	---	20	V	Open-drain and active low. Connect a 10K resistor in series with the pin. The maximum pin/terminal voltage should not exceed 20V

* Engineering Estimate.

** The module has no remote sense pins. Care must be taken when measuring Vo to minimize the IR drop across the output pins.

† Contact TDK-Lambda for applications that require additional capacitance or very low ESR.

Electrical Characteristics: iQK4N090A112V-1xx: 11.2V, 90A, 1008W Output

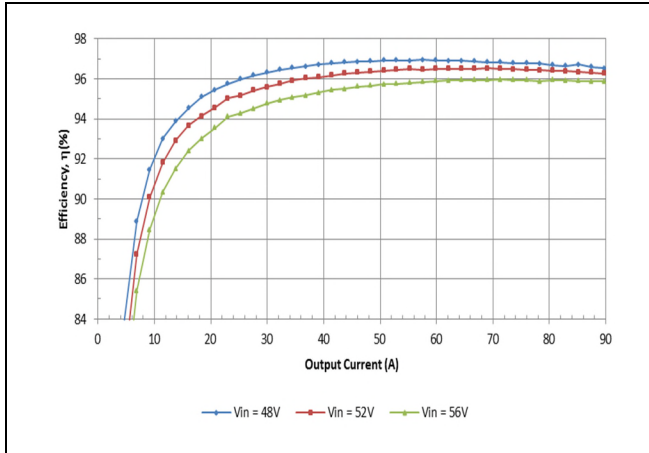

Typical Efficiency vs. Vin and Io (no Droop).

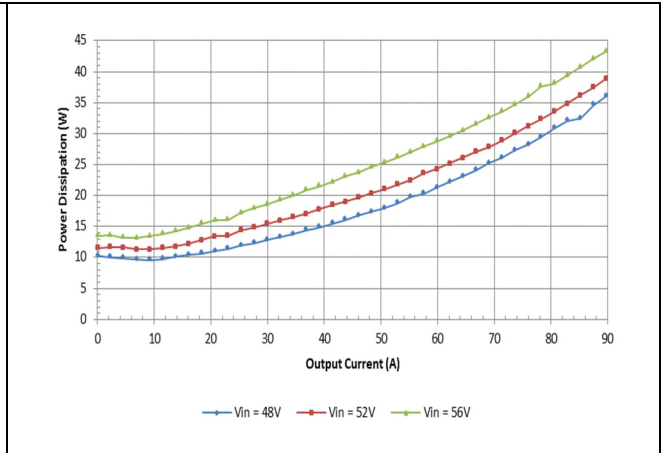

Power Dissipation vs. Vin and Io (no Droop).

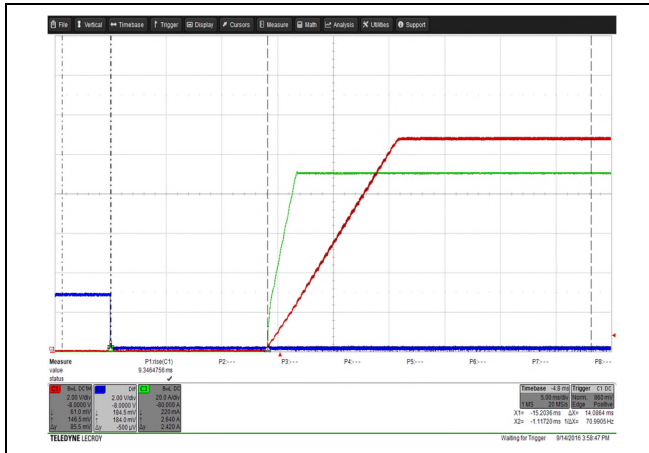

Start-up from On/Off Switch at Vin,nom and Full Load
CH1: Vo, CH2: On/Off, CH3: Io.

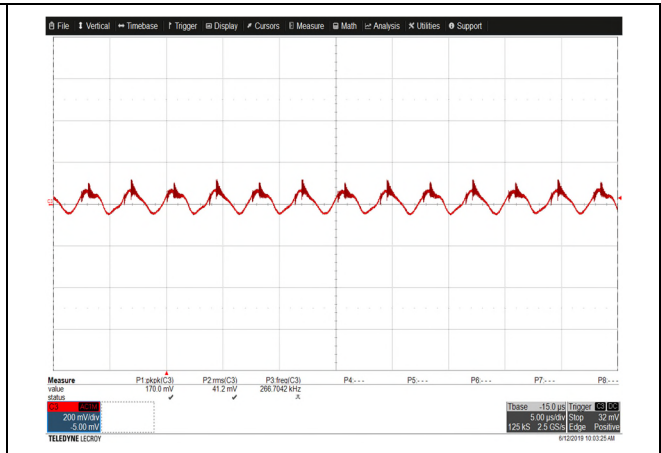

Typical Output Ripple at Vin,nom & Full Load, Ta = 25 °C. CH1: Vo.

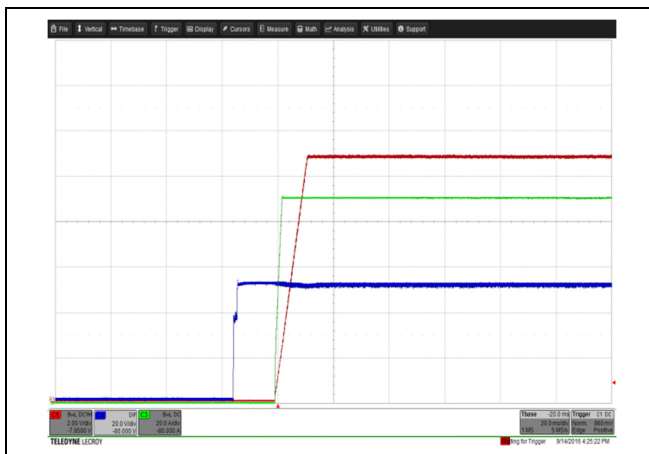

Start-up from Input Voltage application at Full Load. CH1: Vo, CH2: Vin, CH3: Io.

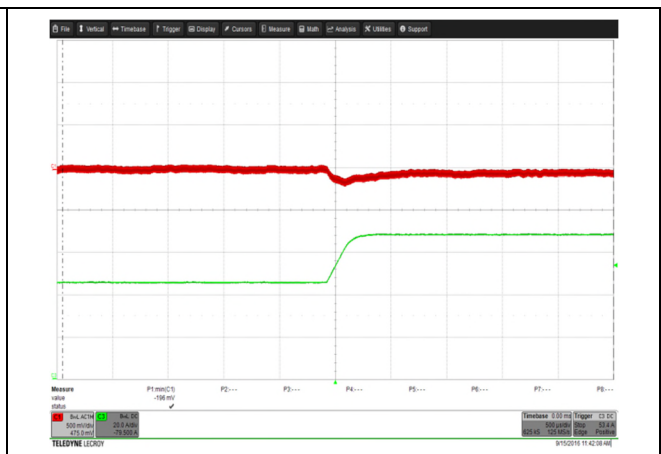

Load Transient Response. Load Step from 50% to 75% of Full Load with di/dt= 0.1A/μs. CH1: Vo, CH3: Io.

Electrical Characteristics: iQK4N090A112V-1xx: 11.2V, 90A, 1008W Output

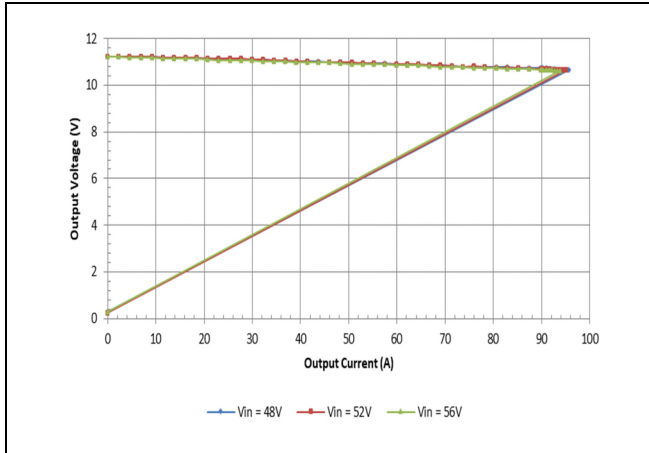

Typical Output Current Limit Characteristics vs. Vin.

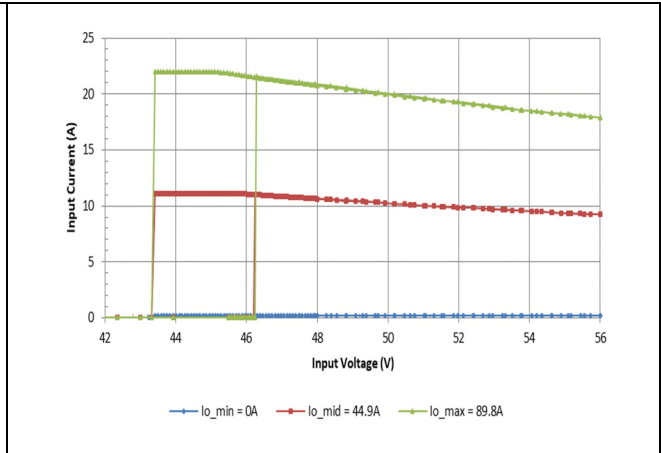

Typical Input Current vs. Input Voltage Characteristics.

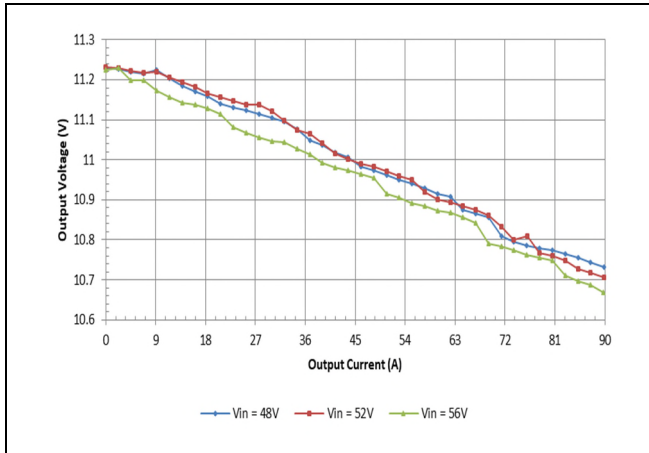

Typical Output Voltage vs. Load Current (droop option) at Ta = 25 °C.

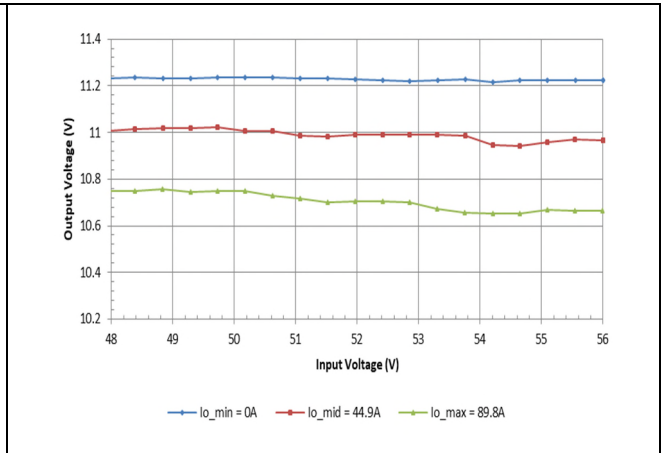

Typical Output Voltage vs. Input Voltage (Droop option) at Ta = 25 °C.

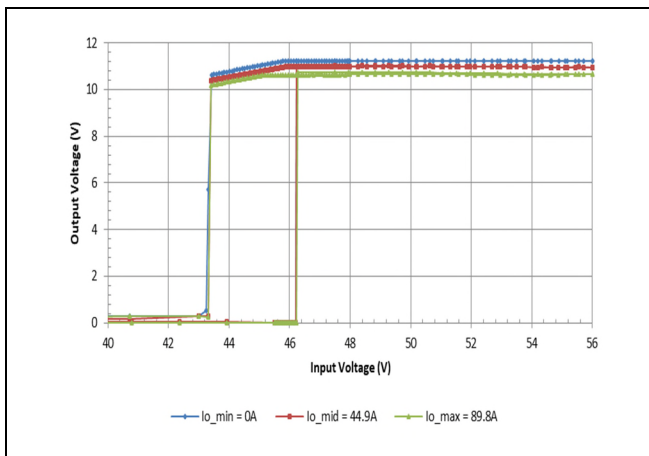

Typical Output vs. Input Turn-On & Turn-Off at Ta = 25 °C.

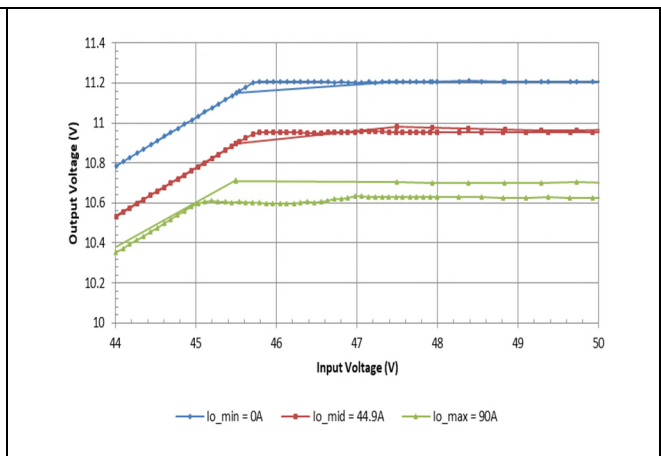

Output Voltage vs. Vin (between 45V and 50V input)

Electrical Characteristics: iQK4N090A112V-1xx: 11.2V, 90A, 1008W Output

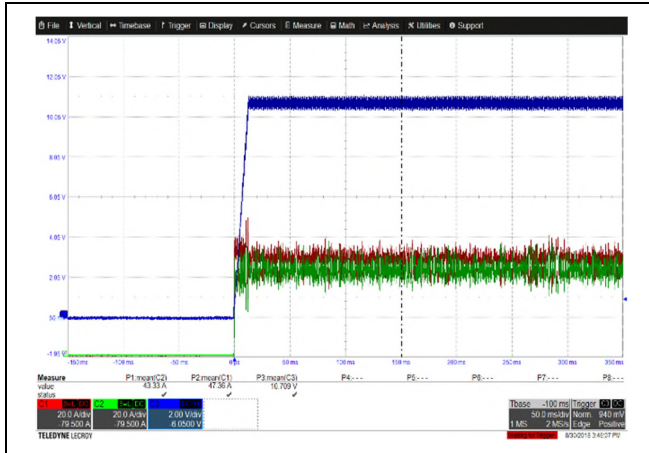

Two units (worst case) start-up from On/Off switch, $I_o = 90A$, CH1: I_{o1} , CH2: I_{o2} , CH3: V_o .

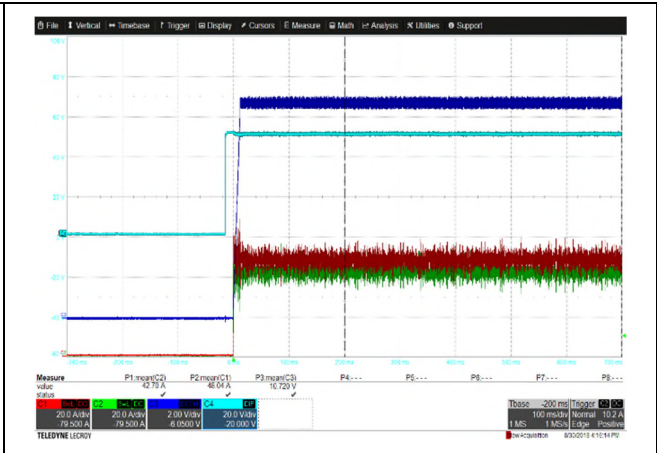

Two units (worst case) start-up from V_{in} , $I_o = 90A$, CH1: I_{o1} , CH2: I_{o2} , CH3: V_o , CH4: V_{in} .

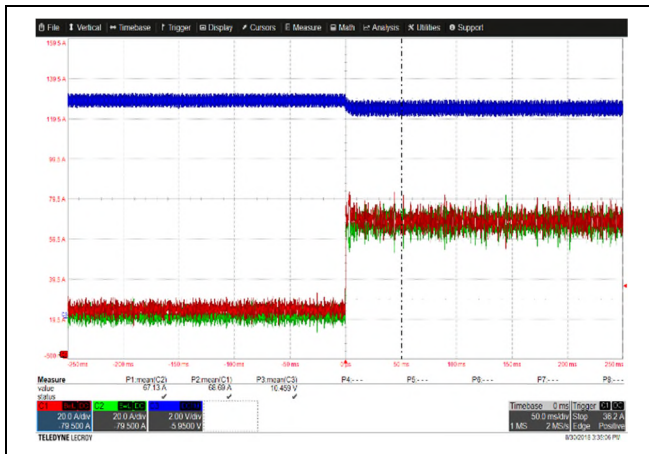

Load Transient Response (worst case). $I_o = 45A$ to $135A$, $1A/\mu s$ slew rate. CH1: I_{o1} , CH2: I_{o2} , CH3: V_o .

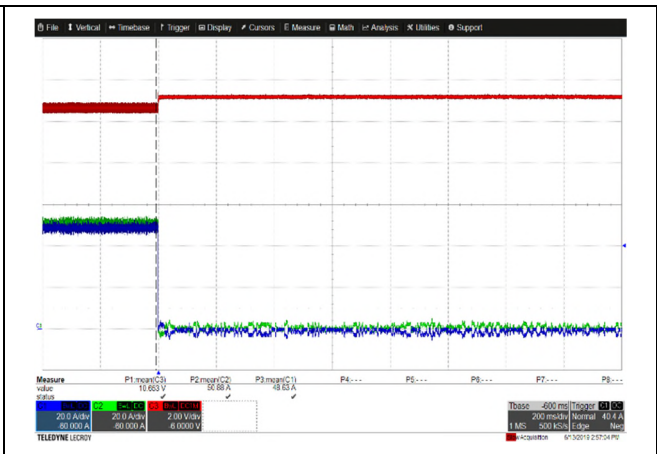

Load Transient Response (worst case). $I_o = 100A$ to $0A$, $1A/\mu s$ slew rate. CH1: I_{o1} , CH2: I_{o2} , CH3: V_o .

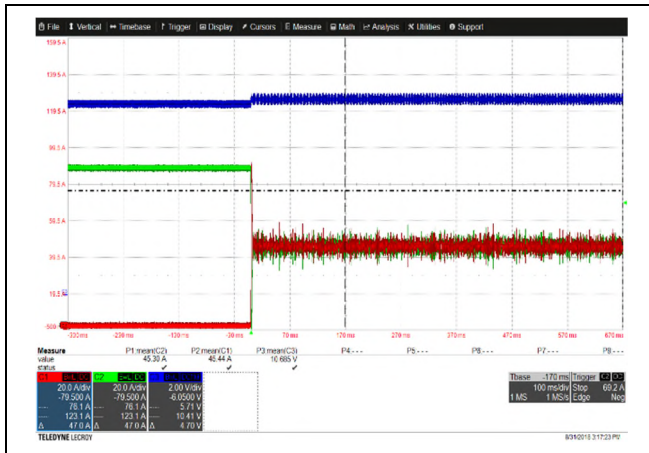

Start-up with back bias (worst case) @ $I_o = 90A$. CH1: I_{o1} , CH2: I_{o2} , CH3: V_o .

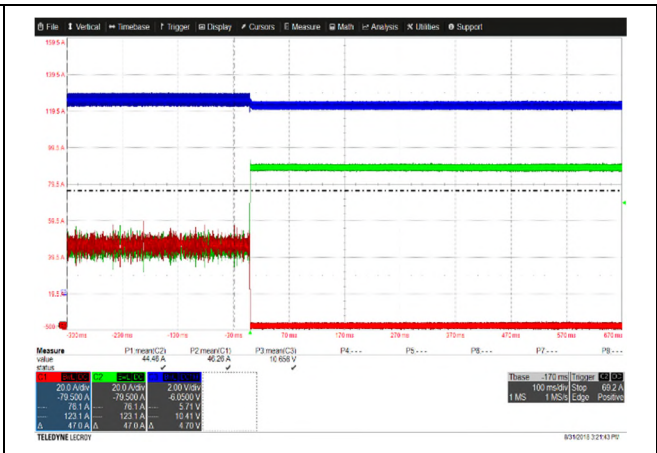

Power down with back bias (worst case) @ $I_o = 90A$. CH1: I_{o1} , CH2: I_{o2} (long load cable), CH3: V_o .

NOTE: To guarantee successful start-up of a multi-module system, the initial load current to the system should be no more than a single module's maximum current rating before the output voltage reaches its final value.

Thermal Performance: iQK4N090A112V-1xx: 11.2V, 90A, 1008W Output

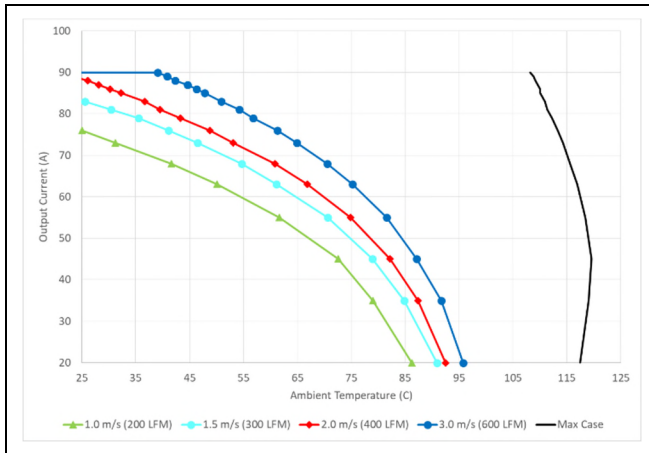

Maximum output current vs. ambient temperature at nominal input voltage with baseplate plus thermal enhancement for airflow rates 1m/s (200LFM) to 3m/s (600LFM) with airflow from pin 3 to pin 1.

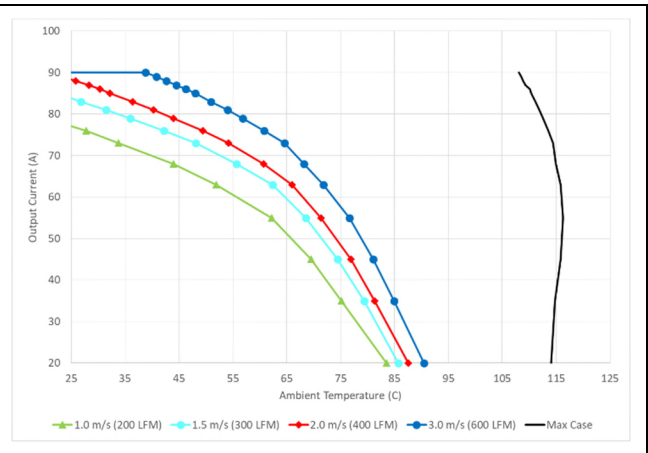

Maximum output current vs. ambient temperature at nominal input voltage with baseplate plus thermal enhancement for airflow rates 1m/s (200LFM) to 3m/s (600LFM) with airflow from pin 1 to pin 3.

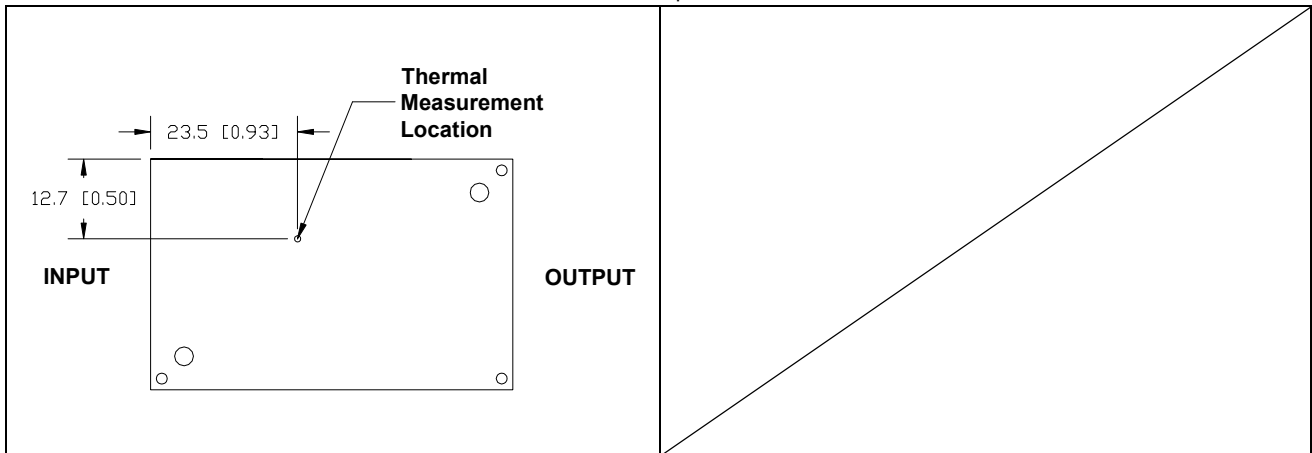

Thermal measurement location for base plate option – top view.

The thermal curves provided are based upon measurements made in TDK-Lambda's experimental test setup that is described in the Thermal Management section. Due to the large number of variables in system design, TDK-Lambda recommends that the user verify the module's thermal performance in the end application. The critical component should be thermo-coupled and monitored, and should not exceed the temperature limit specified in the derating curve above. It is critical that the thermocouple be mounted in a manner that gives direct thermal contact otherwise significant measurement errors may result.

Thermal Management

An important part of the overall system design process is thermal management; thermal design must be considered at all levels to ensure good reliability and lifetime of the final system. Superior thermal design and the ability to operate in severe application environments are key elements of a robust, reliable power module.

A finite amount of heat must be dissipated from the power module to the surrounding environment. This heat is transferred by the three modes of heat transfer: convection, conduction and radiation. While all three modes of heat transfer are present in every application, convection is the dominant mode of heat transfer in most applications. However, to ensure adequate cooling and proper operation, all three modes should be considered in a final system configuration.

Test Setup:

The thermal performance data of the power module is based upon measurements obtained from a wind tunnel test with the setup shown in the wind tunnel figure. This thermal test setup replicates the typical thermal environments encountered in most modern electronic systems with distributed power architectures. The electronic equipment in datacom, telecom, wireless, and advanced computer systems operates in similar environments and utilizes vertically mounted printed circuit boards (PCBs) or circuit cards in cabinet racks.

The power module, as shown in the figure, is mounted on a printed circuit board (PCB) and is vertically oriented within the wind tunnel. The cross section of the airflow passage is rectangular. The spacing between the top of the module and a parallel facing PCB is kept at a constant (0.5 in). The power module's orientation with respect to the airflow direction can have a significant impact on the module's thermal performance.

Thermal Derating

For proper application of the power module in a given thermal environment, output current de-rating curves are provided as a design guideline on the Thermal Performance section for the power module of interest. The module temperature should be measured in the final system configuration to ensure proper thermal management of the power module. For thermal performance verification, the module temperature should be measured at the component indicated in the thermal measurement location figure on the thermal performance page for the power module of interest.

In all conditions, the power module should be operated below the maximum operating temperature shown on the de-rating curve. For improved design margins and enhanced system reliability, the power module may be operated at temperatures below the maximum rated operating temperature

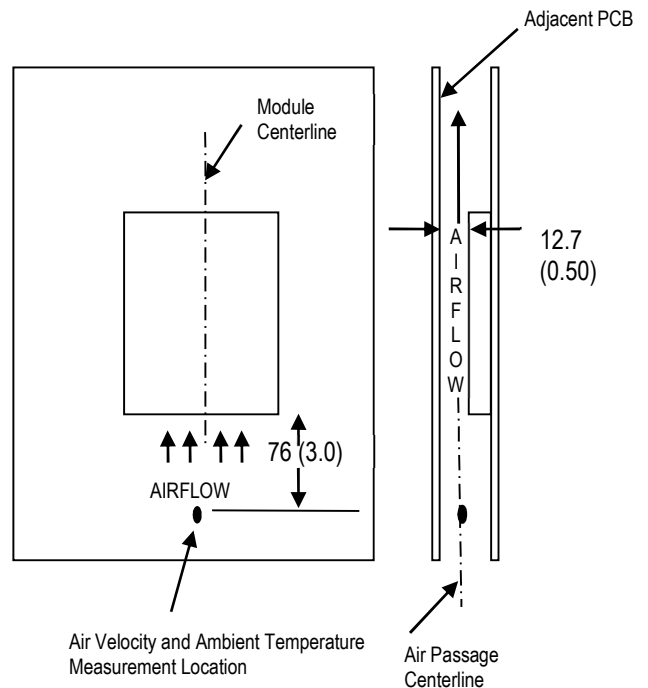

Wind Tunnel Test Setup Figure

Dimensions are in millimeters and (inches).

Heat transfer by convection can be enhanced by increasing the airflow rate that the power module experiences. The maximum output current of the power module is a function of ambient temperature (T_a) and airflow rate as shown in the thermal performance figures on the thermal performance page for the power module of interest. The curves in the figures are shown for 1 m/s (200 ft/min) through 3 m/s (600ft/min).

Heatsink Usage:

For applications with demanding environmental requirements, such as higher ambient temperatures or higher power dissipation, the thermal performance of the power module can be improved by attaching a heatsink or cold plate. The iQK platform is designed with a base plate with two M3 X 0.5 threaded inserts for attaching a heatsink or cold plate. The addition of a heatsink can reduce the airflow requirement; ensure consistent operation and extended reliability of the system. With improved thermal performance, more power can be delivered at a given environmental condition.

The system designer must use an accurate estimate or actual measure of the internal airflow rate and temperature when doing the heatsink thermal analysis. For each application, a review of the heatsink fin orientation should be completed to verify proper fin alignment with airflow direction to maximize the heatsink effectiveness.

Operating Information:

Over-Current Protection:

The power modules have current limit protection to protect the module during output overload and short circuit conditions. During overload conditions, the power modules may protect themselves by entering a hiccup current limit mode. The modules will operate normally once the output current returns to the specified operating range. A latched over-current protection option is also available. Consult the TDK-Lambda technical support for details.

Output Over-Voltage Protection:

The power modules have a control circuit, independent of the main control loop, that reduces the risk of over voltage appearing at the output of the power module during a fault condition. If there is a fault in the main regulation loop, the over voltage protection circuitry will latch the power module off once it detects the output voltage condition as specified on the Electrical Data page. To remove the module from the latched condition, either cycle the input power or toggle the remote On/Off pin providing that over-voltage conditions have been removed. The reset time of the On/Off pin should be 500ms or longer.

An optional non-latching OVP protection feature is also available. Consult the TDK-Lambda technical support for details.

Thermal Protection:

When the power modules exceed the maximum operating temperature, the modules will turn-off to safeguard the units against thermal damage. The module will auto restart as the unit is cooled below the over temperature threshold. A latched over-temperature protection option is also available. Consult the TDK-Lambda technical support for details.

Remote On/Off:

The power modules have an internal remote On/Off circuit. The user must supply an open-collector or compatible switch between the Vin(-) pin and the On/Off pin. The maximum voltage generated by the power module at the On/Off terminal is 15V. The maximum allowable leakage current of the switch is 50 μ A. The switch must be capable of maintaining a low signal $V_{on/off} < 0.8V$ while sinking 200 μ A.

The standard On/Off logic is negative logic. The module will turn on if pin 2 is connected to pin 3, and it will be off if pin 2 is left open. If the negative logic feature is not being used, pin 2 should be shorted to pin 3.

An optional positive logic is available. The power module will turn on if pin 2 is left open and will be off if pin 2 is connected to pin 3. If the positive logic circuit is not being used, terminal 2 should be left open.

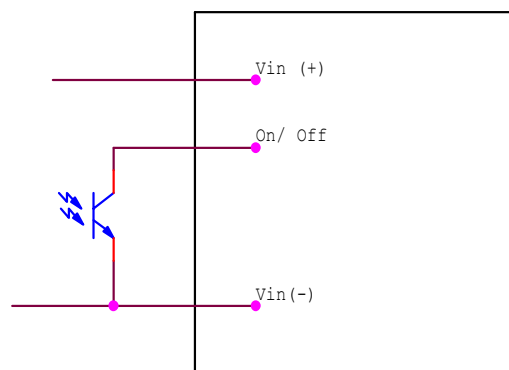

On/Off Circuit for positive or negative logic

Power Good:

iQK modules are equipped with a Power Good pin to communicate with the downstream POLs when the output voltage is within the pre-specified range. iQK is running normal when the Power Good pin is at low. A pull-up resistor of 10K is recommended to be connected with this pin.

EMC Considerations:

TDK-Lambda power modules are designed for use in a wide variety of systems and applications. With the help of external EMI filters and careful layout, it is possible to meet CISPR 22 class A or B requirement. For assistance with designing for EMC compliance, please contact TDK-Lambda technical support.

Input Impedance:

The source impedance of the power feeding the DC/DC converter module will interact with the DC/DC converter. To minimize the interaction, two 220 μ F / 100V input electrolytic capacitors are recommended.

Input/Output Ripple and Noise Measurements:

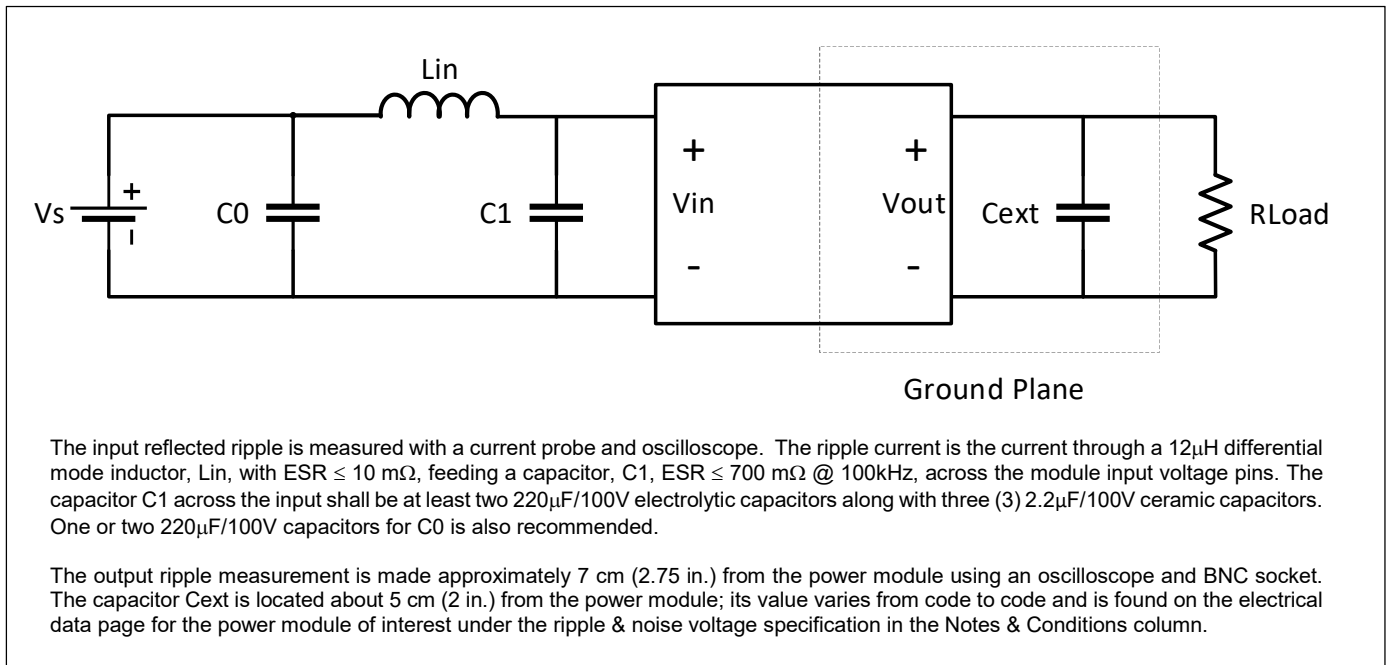

Reliability:

The power modules are designed using TDK-Lambda's stringent design guidelines for component derating, product qualification, and design reviews. Early failures are screened out by both burn-in and an automated final test. The MTBF is calculated to be above 2.7M hours at nominal input, full load, and $T_a = 40^\circ\text{C}$ using the Telcordia TR-332 issue 6 method.

Improper handling or cleaning processes can adversely affect the appearance, testability, and reliability of the power modules. Contact TDK-Lambda technical support for guidance regarding proper handling, cleaning, and soldering of TDK-Lambda's power modules.

Quality:

TDK-Lambda's product development process incorporates advanced quality planning tools such as FMEA and C_{pk} analysis to ensure designs are robust and reliable. All products are assembled at ISO certified assembly plants.

Warranty:

TDK-Lambda's comprehensive line of power solutions includes efficient, high-density DC-DC converters. TDK-Lambda offers a three-year limited warranty. Complete warranty information is listed on our web site or is available upon request from TDK-Lambda.

Safety Considerations:

For safety agency approval of the system in which the DC-DC power module is installed, the power module must be installed in compliance with the creepage and clearance requirements of the safety agency. The isolation is functional insulation.

As part of the production process, the power modules are hi-pot tested from primary and secondary at a test voltage of 707Vdc.

To preserve maximum flexibility, the power modules are NOT internally fused. An external input line fast blow fuse with a maximum value of 30A is required by safety agencies. A lower value fuse can be selected based upon the maximum dc input current and inrush energy of the module.

When the supply to the DC-DC converter is less than 60Vdc, the power module meets all of the requirements for SELV. If the input voltage is a hazardous voltage that exceeds 60Vdc, the output can be considered SELV only if the following conditions are met:

- 1) The input source is isolated from the ac mains by reinforced insulation.
- 2) The input terminal pins are not accessible.
- 3) One pole of the input and one pole of the output are grounded or both are kept floating.
- 4) Single fault testing is performed on the end system to ensure that under a single fault, hazardous voltages do not appear at the module output.

Information furnished by TDK-Lambda is believed to be accurate and reliable. However, TDK-Lambda assumes no responsibility for its use, nor for any infringement of patents or other rights of third parties, which may result from its use. No license is granted by implication or otherwise under any patent or patent rights of TDK-Lambda. TDK components are not designed to be used in applications, such as life support systems, wherein failure or malfunction could result in injury or death. All sales are subject to TDK-Lambda's Terms and Conditions of Sale, which are available upon request. Specifications are subject to change without notice.



TDK-Lambda France SAS

Tel: +33 1 60 12 71 65
france@fr.tdk-lambda.com
www.emea.lambda.tdk.com/fr



Italy Sales Office

Tel: +39 02 61 29 38 63
info.italia@it.tdk-lambda.com
www.emea.lambda.tdk.com/it



Netherlands

info@nl.tdk-lambda.com
www.emea.lambda.tdk.com/nl



TDK-Lambda Germany GmbH

Tel: +49 7841 666 0
info.germany@de.tdk-lambda.com
www.emea.lambda.tdk.com/de



Austria Sales Office

Tel: +43 2256 655 84
info@at.tdk-lambda.com
www.emea.lambda.tdk.com/at



Switzerland Sales Office

Tel: +41 44 850 53 53
info@ch.tdk-lambda.com
www.emea.lambda.tdk.com/ch



Nordic Sales Office

Tel: +45 8853 8086
info@dk.tdk-lambda.com
www.emea.lambda.tdk.com/dk



TDK-Lambda UK Ltd.

Tel: +44 (0) 12 71 85 66 66
powersolutions@uk.tdk-lambda.com
www.emea.lambda.tdk.com/uk



TDK-Lambda Ltd.

Tel: +9 723 902 4333
info@tdk-lambda.co.il
www.emea.lambda.tdk.com/il



C.I.S.

Commercial Support:

Tel: +7 (495) 665 2627

Technical Support:

Tel: +7 (812) 658 0463
info@tdk-lambda.ru
www.emea.lambda.tdk.com/ru



TDK-Lambda Americas

Tel: +1 800-LAMBDA-4 or 1-800-526-2324
powersolutions@us.tdk-lambda.com
www.us.lambda.tdk.com



TDK Electronics do Brasil Ltda

Tel: +55 11 3289-9599
sales.br@tdk-electronics.tdk.com
www.tdk-electronics.tdk.com/en



TDK-Lambda Corporation

Tel: +81-3-6778-1113
www.jp.lambda.tdk.com



TDK-Lambda (China) Electronics Co. Ltd.

Tel: +86 21 6485-0777
powersolutions@cn.tdk-lambda.com
www.lambda.tdk.com.cn



TDK-Lambda Singapore Pte Ltd.

Tel: +65 6251 7211
tis.mkt@sg.tdk-lambda.com
www.sg.lambda.tdk.com



TDK India Private Limited, Power Supply Division

Tel: +91 80 4039-0660
mathew.philip@in.tdk-lambda.com
www.sg.lambda.tdk.com

