

**PH150A280**

C263-01-01G

SPECIFICATIONS

ITEMS		MODEL	PH150A280-12	PH150A280-15	PH150A280-24	PH150A280-28	PH150A280-48
1	Nominal Output Voltage	V	12	15	24	28	48
2	Maximum Output Current	A	12.5	10	6.3	5.4	3.2
3	Maximum Output Power	W	150	150	151.2	151.2	153.6
4	Efficiency (Typ.)	(*1) %	88	90	89	90	90
5	Input Voltage Range	VDC	200 - 425				
6	Input Current	(*1) A	0.62	0.60	0.61	0.61	0.6
7	Output Voltage Accuracy	(*1) %	-/+ 2				
8	Output Voltage Range	(*8) %	-20 / +10				
9	Maximum Ripple & Noise	(*8) mV	150	150	240	280	400
10	Maximum Line Regulation	(*2) mV	24	30	48	56	96
11	Maximum Load Regulation	(*3) mV	24	30	48	56	96
12	Over Current Protection	(*4) %	102 - 150				
13	Over Voltage Protection	(*5)(*7) %	115 - 145				
14	Remote Sensing	(*7) -	Possible				
15	Remote ON/OFF Control	(*7) -	Possible (SHORT : ON OPEN : OFF)				
16	Parallel Operation	-	-				
17	Series Operation	(*7) -	Possible				
18	Operating Temperature	(*6) -	-40°C - +100°C (Baseplate), -40°C - +85°C(Ambient)				
19	Operating Humidity	-	5 - 95%RH (No Dewdrop)				
20	Storage Temperature	-	-40°C - +100°C				
21	Storage Humidity	-	5 - 95%RH (No Dewdrop)				
22	Cooling	-	Conduction Cooled				
23	Temperature Coefficient	-	0.02%/°C				
24	Withstand Voltage	(*9) -	Input-Baseplate : 2.5kVAC for 1min (20mA), Input-Output: 3.0kVAC for 1min (20mA). Output-Baseplate for 1min (20mA): 500VAC				
25	Isolation Resistance	-	More than 100MΩ at 25°C and 70%RH Output-Baseplate...500VDC				
26	Vibration	-	At No Operating, 10-55Hz (Sweep for 1min.) Amplitude 0.825mm Constant (Maximum 49.0m/s <sup>2</sup> ) X,Y,Z 1 hour each				
27	Shock	-	196.1m/s <sup>2</sup>				
28	Safety	-	Approved by UL62368-1, CSA62368-1, EN62368-1, UL60950-1, CSA60950-1, EN60950-1 (Expire date of 60950-1 : 20/12/2020)				
29	Weight (Typ.)	g	55				
30	Size (W x H x D)	mm	37.2 x 12.7 x 58.3 (Refer to Outline Drawing)				

\*Read instruction manual carefully, before using the power supply unit.

Derating Curve

=NOTES=

- \*1. At 280VDC and maximum output current.  
(Baseplate Temperature = +25°C)
- \*2. 200 - 425VDC, Constant load.
- \*3. No Load - Full Load, Constant input voltage.
- \*4. Constant current limiting.
- \*5. OVP reset : Line off or Control off.
- \*6. Rating - Refer to Derating Curve on the right.  
- Load(%) is percent of maximum output current.  
- Refer to Instruction Manual.
- \*7. Refer to Instruction Manual.
- \*8. External components are necessary for operation.  
(Refer to Basic Connection and Instruction Manual.)
- \*9. This specification applies to power supply module as stand-alone.

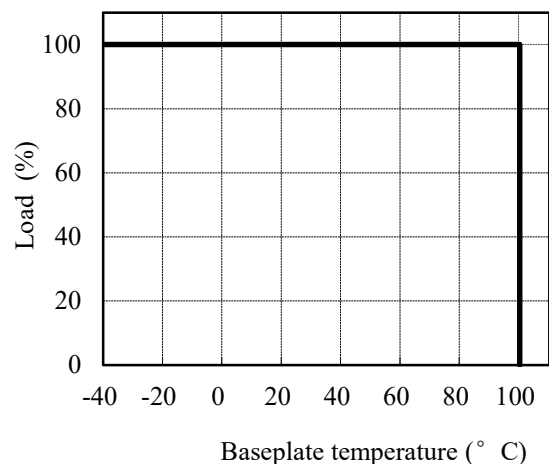

**PH150A280**

C263-01-02B

BASIC CONNECTION

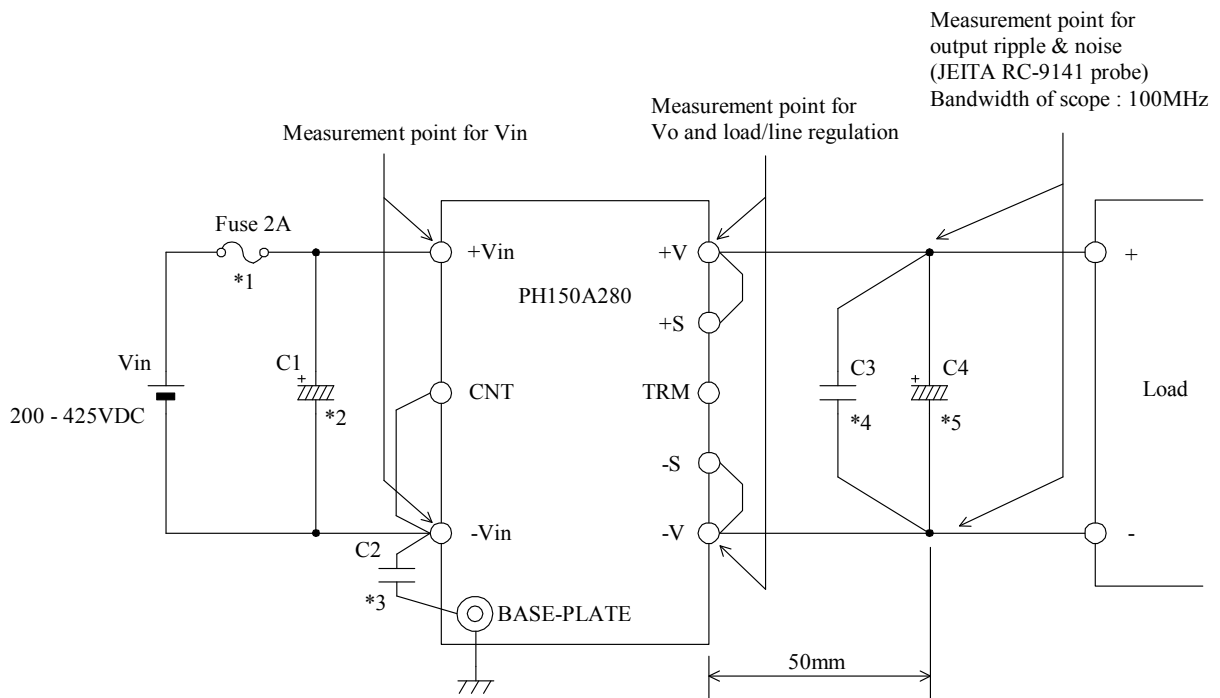

\*Read instruction manual carefully, before using the power supply unit.

==NOTES==

\*1. Use an external fuse (fast blow type or normal blow type) for each unit.

\*2. Put input capacitor.

C1 : Electrolytic capacitor More than 450VDC, 22 $\mu$ F

- 1) Use low impedance electrolytic capacitor with excellent temperature characteristics.
- 2) Use two capacitors(450V, 22 $\mu$ F) in parallel when ambient temperature is -20 $^{\circ}$ C or lower to reduce ESR.
- 3) If the impedance of input line is high, C1 capacitance must be more than above.

\*3. Put FG capacitor.

C2 : Ceramic capacitor more than 2.5kVAC, 470pF

\*4. Put output capacitor.

C3 : Ceramic capacitor 100VDC, 2.2 $\mu$ F

\*5. Put output capacitor.

C4 : Electrolytic capacitor

C4	12V,15V: 25VDC , 560 $\mu$ F
	24V,28V: 50VDC , 220 $\mu$ F
	48V : 50VDC , 220 $\mu$ F x 2 Series

- 1) Use low impedance electrolytic capacitor with excellent temperature characteristics.
- 2) Use more than three recommended capacitor above in parallel when ambient temperature is -20 $^{\circ}$ C or lower to reduce ESR.