

**GENESYS™**

**GH1kW**

**EN61000**

**DATA**

DWG: IA882-58-01		
APPD	CHK	DWG
<i>Oraniv</i> <i>02/06/20</i>	<i>Song</i> <i>01.06.2020</i>	Michael Goldberg 31/05/2020

**TDK-LAMBDA**

## List of equipment used

EQUIPMENT USED		MANUFACTURER	MODEL No.
1	Storage oscilloscope	Yokogawa	DL1740
2	Digital multimeter	HP	34401A
3	Digital power meter	Yokogawa	WT130
4	Autotransformer	Metrel	HSN 260/30
5	Autotransformer	Metrel	HTN 450/20
6	Resistive load	NLI	10V
7	Resistive load	NLI	600V
8	AC source	Chroma	6590
9	ESD simulator system	Schaffner-Chase EMC	NSG435
10	EFT/B Generator	EMV-System Schloder	SFT400
11	Surge Generator	EM Test	UCS 500-M4
12	RF Signal Generator 9kHz-1.2GHz	Marconi Instruments	2023
13	Coupling/Decoupling Network	Hermon Lab	300-M3
14	Coupling/Decoupling Network	Hermon Lab	S-T
15	Power amplifier, 150kHz-250 MHz	Com-Power Cor.	ACS-250-100W
16	Surge Generator	EM TEST	UCS500 -M4
17	AC Power Source	EM TEST	V4070
18	Anechoic test chamber	Hermon Lab	AC-2
19	Antenna, Log Periodic, 200-1000 MHz	Electro-Metrics	LPA 25/30
20	Antenna, biconical, high power 20-300MHz, 1kW	A.H.Systems Inc.	SAS-200/543
21	Antenna, double-ridged waveguide horn, 1-18GHz, 300W	EMC Test Systems	3115
22	RF amplifier, 80MHz to 1000MHz, 500W	Amplifier Research	500W1000A
23	RF amplifier, 1 to 4 GHz, 55W	Milmega AS	0104-55/55B
24	Generator Swept Signal, 10 MHz to 40 GHz, +10 dBm	Hewlett Packard	83640B
25	Antenna mast and Turntable position controller	Sh. I. Machines	CRL-F4
26	Antenna mast with position control	Sh. I. Machines	AM-F4
27	Coupler coaxial bi-directional 1 - 4 GHz, 20 dB	Narda	3022
28	Antenna, 30 MHz - 3.0 GHz	Sunol Sciences Corp.	JB3
29	Hygro Thermometer	Delta TRAK	13301
30	Power Meter,RF, IEEE-48, 100 kHz - 100 GHz	Boonton Eletronics Corp.	4220
31	Horn Antenna, 0.5 to 4 GHz	GTE Sylvania	AN-10E
32	Directional Coupler High Power, 80 to 1000 MHz, 200 W	WERLATONE	C 3910
33	Power Sensor 100 kHz - 18 GHz, -50 to 30 dBm	Boonton Eletronics Corp.	51015 (5E)
34	Precision Fixed Attenuator, 50 Ohm, 5 W, 20 dB	Mini-Circuits	BW-N20W5+
35	Laser Probe Interface	Amplifier Research	FI7000
36	Broadband Amplifier, 80 MHz to 1.0 GHz, 500W	Rohde & Schwarz	BBA150-BC500
37	Broadband Amplifier, 0.69 GHz to 3.2 GHz, 200W	Rohde & Schwarz	BBA150-D200
38	Broadband Amplifier, 2.5 GHz to 6.0 GHz, 200W	Rohde & Schwarz	BBA150-E200
39	Probe, E-field, isotropic, 0.2 MHz to 26 GHz	General Microwave	84C
40	Signal Analyzer System, 4 channels	Data Physic	DP240
41	Thermal Power Sensor, DC to 18 GHz	Rohde & Schwarz	NRP18T

INDEX	PAGE
1. Electro-Static Discharge Test EN61000-4-2 .....	R-1
2. Radiated Susceptibility Test EN61000-4-3.....	R-2

The above data is typical value.

The values are considered to be actual capability data.

# 1. Electrostatic discharge (ESD) (IEC 61000-4-2; EN 61204-3/ IEC 61204-3)

**(1) Equipment used:**

ESD simulator system: Schaffner-Chase EMC NSG435  
 Discharge resistance: 470kΩ X 2

**(2) Test conditions:**

Input voltage:	Rated	Output voltage:	Rated
Output current:	100%	Polarity:	-,+
Number of tests:	10 Positive/ 10 Negative	Discharge interval:	>1 Second

**(3) Test setup:**

Contact discharge: FG, Case screw  
 Air discharge: Input and Output terminal

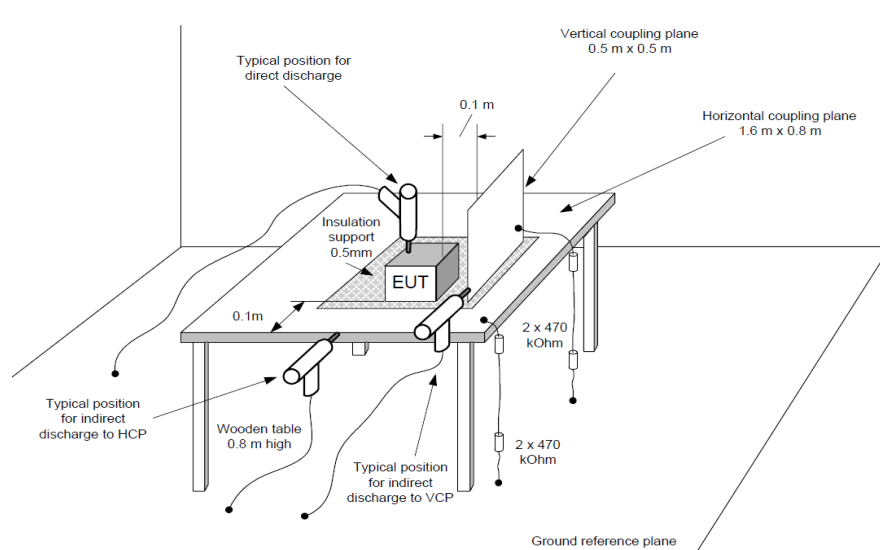

**(4) Acceptable conditions:**

1. Output voltage regulation not to exceed  $\pm 5\%$  of initial (before test) value during test.
2. Output voltage to be within regulation specification after the test.
3. Along with 1 and 2, no discharge of fire or smoke, as well as no output failure.

**(5) Test result:**

Discharge (kV)	Contact discharge		Air discharge	
	GH600-1.7	GH600-1.7	Discharge (kV)	GH600-1.7
2	PASS	PASS	2	PASS
4	PASS	PASS	4	PASS
			8	PASS

## 2. Radiated immunity to radio frequency electromagnetic field (IEC 61000-4-3; EN 61204-3/ IEC 61204-3)

### (1) Equipment used:

Anechoic test chamber	Hermon Labs AC-2
Antenna, Log Periodic, 200-1000 MHz	Electro-Metrics LPA 25/30
Antenna, biconical, high power 20-300MHz, 1kW	A.H.Systems Inc. SAS-200/543
Antenna, double-ridged waveguide horn, 1-18GHz, 300W	EMC Test Systems 3115
RF amplifier, 80MHz to 1000MHz, 500W	Amplifier Research 500W1000A
RF amplifier, 1 to 4 GHz, 55W	Milmega AS 0104-55/55B
Generator Swept Signal, 10 MHz to 40 GHz, +10 dBm	Hewlett Packard 83640B
Antenna mast and Turntable position controller	Sh. I. Machines CRL-F4
Antenna mast with position control	Sh. I. Machines AM-F4
Coupler coaxial bi-directional 1 - 4 GHz, 20 dB	Narda 3022
Antenna, 30 MHz - 3.0 GHz	Sunol Sciences Corp. JB3
Hygro Thermometer	Delta TRAK 13301
Power Meter,RF, IEEE-48, 100 kHz - 100 GHz	Boonton Eletronics Corp. 4220
Horn Antenna, 0.5 to 4 GHz	GTE Sylvania AN-10E
Directional Coupler High Power, 80 to 1000 MHz, 200 W	WERLATONE C 3910
Power Sensor 100 kHz - 18 GHz, -50 to 30 dBm	Boonton Eletronics Corp. 51015 (5E)
Precision Fixed Attenuator, 50 Ohm, 5 W, 20 dB	Mini-Circuits BW-N20W5+
Laser Probe Interface	Amplifier Research FI7000
Broadband Amplifier, 80 MHz to 1.0 GHz, 500W	Rohde & Schwarz BBA150-BC500
Broadband Amplifier, 0.69 GHz to 3.2 GHz, 200W	Rohde & Schwarz BBA150-D200
Broadband Amplifier, 2.5 GHz to 6.0 GHz, 200W	Rohde & Schwarz BBA150-E200
Probe, E-field, isotropic, 0.2 MHz to 26 GHz	General Microwave 84C
Signal Analyzer System, 4 channels	Data Physics DP240
Thermal Power Sensor, DC to 18 GHz	Rohde & Schwarz NRP18T

### (2) Test conditions and test setup:

Input voltage:	Rated	Output voltage:	Rated
Output current:	100%	Amplitude Modulated:	80%,1kHz
Electromagnetic Frequency:	80~2700MHz	Ambient temperature:	25°C
Sweep Condition:	1.5 x 10 <sup>-3</sup> Decade/Second,1.0 Second Hold		

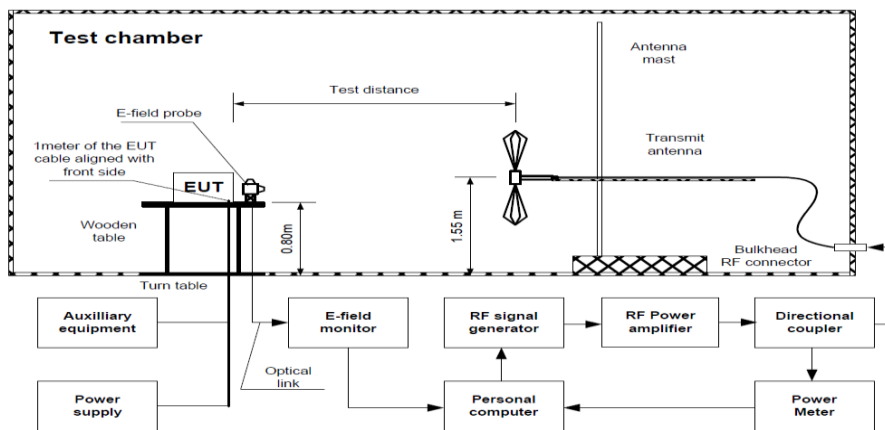

### (3) Acceptable conditions:

1. Output voltage regulation not to exceed ± 5% of initial (before test) value during test.
2. Output voltage to be within regulation specification after the test.
3. Along with 1 and 2, no discharge of fire or smoke, as well as no output failure.

### (4) Test Result:

Frequency (GHz)	Radiated Field Strength (Vrms/m)	GH600-1.7
0.08-1	10	PASS
1.4-2	3	PASS
2-2.7	1	PASS